

The University of Adelaide

Investigation of PV module performance for solar racing vehicle

*Supervisor:
PhD. Steven Grainger
In collaboration with
Tindo Solar*



Engineer. Abdulaziz Alghamdi
The School of Mechanical Engineering

Table of Contents

Table of Contents	1
Figures	4
Tables.....	6
Acknowledgment	10
1. Introduction	11
2. Literature Review	12
2.1. Solar System	12
2.1.1. Maximum Power Point Tracking (MPPT)	12
2.1.2. Battery	15
2.1.3. Load	16
2.2. Solar cells.....	17
2.2.1. Solar cell varieties.....	17
2.2.2. Properties and Operating Conditions	20
2.2.3. Encapsulation	22
2.3. Covering materials	23
2.3.1. EVA (Ethylene Vinyl Acetate)	23
2.3.2. PET (Polyester Terephthalate)	23
2.3.3. Front Glass	23
2.3.4. ETFE (Ethylene Tetrafluoroethylene)	23
2.3.5. PVDF (Polyvinylidene Fluoride),	23
2.3.6. Back Sheet.....	24
2.4. Commercial Context.....	24
2.4.1. Lamination	25
2.4.2. Durability	26
2.5. Solar Racing Vehicles.....	26
2.6. Research Gap	27
3. Aim.....	28
4. Method	29
4.1. Outdoor Condition	29
4.2. Indoor Condition	30

5.	Project Management	30
5.1.	Project Constraints	31
5.1.1.	Testing Conditions	31
5.1.2.	Safety	31
5.1.3.	Time Limitation	31
5.1.4.	Resources	31
5.2.	Budget	31
5.3.	Work Breakdown Structure (WBS).....	32
5.3.1.	Project Deliverables.....	32
5.3.2.	Work Structure	32
5.3.3.	Resources.....	33
5.3.4.	Risk Analysis	33
6.	Design of Outdoor Testing Equipment	35
7.	Testing.....	39
7.1.	The Dark IV test.....	39
7.2.	Spi-Sun Simulator™ 4600SLP	39
7.3.	Electroluminescence (EL) testing	40
7.4.	Hydro Testing.....	41
7.5.	MPPT Testing	41
7.6.	Outdoor Testing	42
7.7.	The rationale for Test Samples	42
7.8.	Plasma Treatment.....	42
8.	Production.....	44
8.1.	Materials.....	44
8.1.1.	EVA	45
8.1.2.	ETFE	46
8.1.3.	PVDF	46
8.1.4.	Back sheet	46
8.1.5.	Solar Cells.....	47
8.1.6.	Tindo Karra 300 PERC	47
8.1.7.	Sunpower C60 Cells	47
8.1.8.	Sunpower MAXEON™ GEN III.....	48

8.2.	Outdoor Condition	49
8.3.	Indoor Condition	50
8.3.1.	Indoor Trial 1	50
8.3.2.	Indoor Trial 2	52
8.3.3.	Indoor Trial 3	55
8.3.4.	Indoor Trial 4	57
8.3.5.	Indoor Trial 5	58
8.4.	Outdoor Results	59
8.5.	Indoor Results	60
8.5.1.	Indoor Results Trial 1	60
8.5.2.	Indoor Results Trial 2	62
8.5.3.	Indoor Results Trial 3	65
8.5.4.	Indoor Results Trial 4	67
8.5.5.	Indoor Results Trial 5	69
8.5.6.	Summary	70
9.	Bridgestone World Solar Challenge Results	70
9.1.	Day One	70
9.2.	Day Two	72
9.3.	Day Three	73
9.4.	Day Four	74
9.5.	Day Five	75
9.6.	Day Six	76
10.	Conclusion	77
11.	Future work	77
11.1.	Durability	77
11.2.	Lamination	78
11.3.	Teflon Sheet Variations	78
12.	Reference	78
13.	Appendix	80
A.	Budget and part list	80
B.	Project Gant chart	80
C.	Race Data (from chase laptop)	80

D. Outdoor testing code and results 80

E. Solar cells datasheet 80

Figures

Figure 1: Basic PV system topology 12

Figure 2: MPPT integrated into the solar system 13

Figure 3: Table of MPPT Methods and Specifications 14

Figure 4: Best Research Cell efficiencies as of 17 July 2018 (NREL) 19

Figure 5: 2017 eclipse effect on the PV cells in 2017 20

Figure 6: Output power Vs the temperature 21

Figure 7: Sign of damage on a cell. (project picture) 22

Figure 8: Sign of crack on a cell. (project picture) 22

Figure 9: Sign of damage on a cell. (project picture) 22

Figure 10: Samples of back sheet defects 24

Figure 11: solar cells manufacturing (JBAO 2019) 25

Figure 12: Commercial view of solar panel construction (Jason 2018) 25

Figure 13: The lamination parameter for commercial module 26

Figure 14: Lumen II Mk II – Solar race vehicle 27

Figure 15: PVDF Module Figure 16: ETFE Module 29

Figure 17: Diagram of the electrical circuit for the outdoor testing 30

Figure 18: Control system components - (project picture) 36

Figure 19: Battery box – (project picture) 37

Figure 20: System recorded data 37

Figure 21: Sign of wrinkles (project picture) 38

Figure 22: Sign of wrinkles (project picture) 38

Figure 23: SPi Sun simulator (from the simulator manual attached in appendix) 39

Figure 24: Example of EL testing showing damaged cells. (project picture) 40

Figure 25: 20 minutes after module #1 in the hydro test. (project picture) 41

Figure 26: The plot above show how the double-sided plasma treatment increases the transmittance 5% more than not treated. 43

Figure 27: This plot shows the difference between the treated and untreated film in three properties, transmission, absorption and scattering. 43

Figure 28: Typical film roll sides – General film roll for PV films 44

Figure 29: Bare cells colour and shape before the encapsulation. (project picture) 45

Figure 30: EVA sheet on the back of the solar cells- (project picture) 45

Figure 31: ETFE Infront of the cells (project picture) 46

Figure 32: PVDF after the encapsulation (project picture) 46

Figure 33: Back sheet sides showing the difference between the adhered side and not adhered side 47

Figure 34 Specification SunPower cell C60 (SunPower C60 datasheet) 48

Figure 35: Specification SunPower cell MAXECON GEN III (SunPower MAXECON GEN III datasheet) 49

Figure 36: (PVDF on the left - ETFE on the right)	50
Figure 37: (Teflon Sheet brown on the top of the arrays).....	50
Figure 38: (Norio's method - the glass is not part of the module).....	51
Figure 39: shows how the cells are placed in before the lamination – (project picture).....	51
Figure 41: Module 1(ETFE/ Cell/ EVA/ Back sheet)	52
Figure 42: Module 2(ETFE/ Cell/ EVA/ ETFE/Back sheet)	52
Figure 43: Module 3(PVDF/ Cell/ EVA/ PVDF/Back sheet)	52
Figure 44: Module 4(PVDF / Cell/ EVA/ Back sheet)	52
Figure 45: Module 6(ETFE / Cell/ EVA/ PVDF/ Back sheet).....	52
Figure 46: Module 6(PVDF / Cell/ EVA/ ETFE/ Back sheet).....	52
Figure 46: Solar cells spacers (project picture)	53
Figure 48: Soldering the cells (project picture)	54
Figure 48: The solar cells spaces whole soldering the cells (project picture)	54
Figure 49: Both modules prior to the lamination. (project picture)	55
Figure 50: Cutting the films to the modules size (project picture)	56
Figure 51: After constructing the modules (project picture)	56
Figure 52: Preparing the modules for the EL testing (project picture).....	57
Figure 53: EL testing scan on the computer (project picture)	57
Figure 54: Spaces should be considered when performing lamination	60
Figure 55: Sample going through hydro testing - (project picture).....	61
Figure 57: Microscope image showing a hole (project picture).....	61
Figure 58: Microscope image showing a hole (project picture).....	62
Figure 59: Microscope image showing a hole (project picture).....	62
Figure 60: Microscope image showing a crack- (project picture)	62
Figure 60: Three-celled sample module	63
Figure 61: Bare cells and the irradiation sensor. - (project picture)	63
Figure 62: EL testing for both modules - (project picture)	65
Figure 63: After lamination (left to right) PVDF , PVDF , ETFE12.5 and ETFE50- (project picture)	66
Figure 64: Before lamination (left to right) PVDF , PVDF , ETFE12.5 and ETFE50 - (project picture)...	67
Figure 65: ETFE12.5 film encapsulated and showing wrinkles - (project picture)	67
Figure 66: EL Testing after lamination from left to Right (ETFE50, PVDF, ETFE12.5, ETFE25) - (project picture)	68
Figure 67: EL Testing before lamination from left to Right (ETFE50, PVDF, ETFE12.5, ETFE25) - (project picture)	69
Figure 68: AUSRT at the finish line after completing the race	70
Figure 69: Day one power in and out Vs the time.....	71
Figure 70: Day one SOC, Speed and motor temperature Vs the time.....	71
Figure 71: Day two power in and out Vs the time	72
Figure 72: Day two SOC, Speed and motor temperature Vs the time	72
Figure 73: Day three power in and out Vs the time	73
Figure 74: Day three SOC, Speed and motor temperature Vs the time	73
Figure 75: Day four power in and out Vs the time	74
Figure 76: Day four SOC, Speed and motor temperature Vs the time	74

Figure 77: Day Five power in and out Vs the time 75
 Figure 78: Day five SOC, Speed and motor temperature Vs the time..... 75
 Figure 79: Day six power in and out Vs the time 76
 Figure 80: Day one SOC, Speed and motor temperature Vs the time..... 76

Tables

Table 1: Batteries type and their Advantages and disadvantages 16
 Table 2: Solar cells generation (S S Verma, 2016) and comparison between them 18
 Table 3: Risk Analysis..... 34
 Table 4: detailed risk analysis 34
 Table 5: Parts and (equipment used for the outdoor testing)..... 42
 Table 6: PV panel information 47
 Table 7: Electrical specification of sunpower C60..... 48
 Table 8: Electrical specification of MAXECON GEN III 48
 Table 9: Difference between the lamination parameters. 58
 Table 10:Simulation results for both modules..... 59
 Table 11: Results of trail 1 60
 Table 12 Results MPPT testing the same irradiation (1000 W/m²)..... 64
 Table 13:Trial 3 MPPT Testing results and notes 66
 Table 14: MPPT Testing results 68
 Table 15: Table showing the MPPT testing..... 69

Acronyms

ACFR	The Australian Centre for Field Robotics
PV	Photo Voltage
MPPT	Maximum Point Power Tracker
DC	Direct Current
BWSC	Bridgestone World Solar Challenge
Li-ion	Lithium ion
NiCd	Nickel cadmium
NiMH	Nickel metal hydride
BMS	Battery Management System
NREL	National Renewable Energy Laboratory
PM	Permanent Magnet
MPPT	Maximum Power Point Tracker
EVA	Ethylene Vinyl Acetate
PET	Polyester Terephthalate
PVDF	polyvinylidene Fluoride
ETFE	Ethylene Tetrafluoroethylene
EL	Electroluminescence
RTC	Real-Time Clock
AC	Alternative Current
SOC	State Of Charge
SC	Short Circuit
OC	Open Circuit

Masters by Coursework Project

Project Final Report

Investigation of PV module performance for solar racing vehicle

Author(s)	Abdulaziz Alghamdi
Student ID of Author(s)	
Project Number	2695
Principal Supervisor	Associate Professor Steven Grainger
Other Supervisor(s) (if applicable)	-
Email Address of Author(s)	abdulaziz.alghamdi@student.adelaide.edu.au
Date of Document Issue	2-Nov-2018
Document Version Number	1.0
Address of Organisation Preparing this report:	School of Mechanical Engineering The University of Adelaide North Terrace, Adelaide, SA, 5005, Australia Tel: (08) 8313 5460
Course Name	MECH ENG 7041A - Masters Project
Course Units	12

School of Mechanical Engineering
The University of Adelaide

STATEMENT OF ORIGINALITY

PLAGIARISM AND COLLUSION

Plagiarism: using another person’s ideas, designs, words or works without appropriate acknowledgement.

Collusion: another person assisting in the production of an assessment submission without the express requirement, or consent or knowledge of the assessor.

CONSEQUENCES OF PLAGIARISM AND COLLUSION

The penalties associated with plagiarism and collusion is designed to impose sanctions on offenders that reflect the seriousness of the University’s commitment to academic integrity. Penalties may include: the requirement to revise and resubmit assessment work, receiving a result of zero for the assessment work, failing the course, expulsion and/or receiving a financial penalty. The penalties are described in the University Policy Academic Dishonesty Procedures

(<http://www.adelaide.edu.au/policies/230?dsn=policy.document;field=data;id=907;m=view>)

DECLARATION

- I declare that all the material I will present for assessment in this course will be my own work except where there is clear acknowledgement and reference to the work of others.
- I have read and understood the University Policy Academic Honesty (<http://www.adelaide.edu.au/policies/?230>)
- I give permission for my assessment work to be reproduced and submitted to other academic staff for the purposes of assessment and to be copied, submitted and retained in a form suitable for electronic checking of plagiarism.

Student Name(s)	Abdulaziz Alghamdi
Student ID(s)	
Signed	
Date	31/10/19

Acknowledgment

A project of this kind requires a tremendous amount of effort from various people. I would like to thank Tindo Solar who generously provided use of their facility, machinery, equipment and the time and expertise of their team members to conduct my testing and my research. My thanks also to AGC Chemical who donated a large volume of samples to the project and provided advice about procedure and methods which proved critical to the projects success. I am also highly indebted to my Senior Project Advisor Dr. Steven Grainger for his guidance, supervision, technical expertise, time and his personal support in completing this project. Thank you also to Dr. Eric Hu and Dr. Sasha Shamshurin for their kind assistance throughout the project and to the completion of this project and to both Mr. Norio Itusami and Mr. Jozeph Kumberger who offered invaluable assistance in technical matters. I also extend my appreciation to other staff members at the University of Adelaide who were involved in the project. My sincerest appreciation to all of you.

1. Introduction

The renewable energy movement responds to an increasing need to generate energy sustainably. Renewable energy, or clean energy, is an alternative approach to generating energy without reliance on fossil fuels or other depletable sources of energy. Solar energy, wind power, tidal wave energy and the harnessing of other natural phenomena are examples of renewable energies that can generate electricity. Engineered approaches, such as solar panels are utilised to harvest the energy to produce electricity sustainably.

Solar cells, also known as PhotoVoltaic (PV) cells or PV panels, are a significant portion of the developing renewable energy market and are expected to become a major energy source in the foreseeable future. PV panels are very fragile and vulnerable to damage, so it is important to incorporate protective factors into their structure and use, including complex cell coverings. The covering materials protect cells, support shape and rigidity and aid in installation and safe handling. However, it is commonly understood that the multiple layers that comprise PV panels reduce their efficiency. Covering materials are not 100% light and energy transparent causing reflection, reduced energy absorption and hence reduction in overall panel performance. This project investigated solar cell energy technology, focusing specifically on the methodologies and material comprising covering materials for cells in solar racing vehicles.

Many solar technology companies produce solar cells for solar racing vehicles including Tindo Solar. Tindo Solar “designs and manufactures technologically advanced solar panels in Australia, for Australia and the world. Tindo Solar is a wholly Australian owned and operated company founded in 2011 focused on increasing manufacturing output and creating Australian jobs in the advanced manufacturing sector.” (TindoSolar 2019). The Tindo Solar facility in Mawson Lakes, Adelaide, South Australia, is equipped with advanced machinery and equipment to examine and test solar modules to ensure high-quality solar modules are produced and delivered to the market. This project was completed in collaboration with Tindo Solar who generously contributed their specialised equipment, the machinery they have in the facility, the time, expertise of their team members for use in this project.

The Bridgestone World Solar Challenge (BWSC) is an event in which teams from around the world drive their solar vehicles from Darwin to Adelaide, down the centre of the Australian outback. BWSC teams must complete the 3000Km route within 7 days. Finishing this race is extremely difficult and teams must adopt innovative approaches in their utilisation of solar technology to provide energy to their vehicles. The BWSC classifies vehicles as Adventure, Cruiser or Challenger class which reflect differing criteria such as energy utilisation and the number of passengers. The Challenger class requires vehicles to be powered solely by solar energy and in this sense, the race exemplifies how solar power potential is being advanced for application in domestic transport contexts. The BWSC event is a motivating force within the solar vehicle industry. This research project developed and tested various novel approaches to constructing PV panel coverings. The most efficient of these novel coverings

were then used in the Adelaide University Solar Racing Team (AUSRT) solar vehicle (Lumin II MK II) in the 2019 BWSC event. For the first time, this vehicle completed the BWSC event and the use of the cells developed in this project have been attributed with its success. This report will describe the research project, results and recommendations for future work.

2. Literature Review

Existing literature describes a variety of mechanisms that facilitate solar cells in their energy production and utilisation. This discussion refers to these various mechanisms as solar systems. In order to understand how novel material coverings have been developed and used in this research project, the conventional approaches for solar systems will be described. Conventional approaches to solar cell technology will also be discussed and a gap in the findings will be identified as justification for this project.

2.1. Solar System

A solar system typically comprises of a PV panel, a Maximum Power Point Tracking (MPPT), an energy storage unit, ie. battery and a load to consume the stored energy. Figure 1 depicts the solar system model widely accepted to be the most common and most efficient. Each component of this model will be discussed as it relates to this research project with the exception of the battery management system (BMS) which is not within the scope of this study.

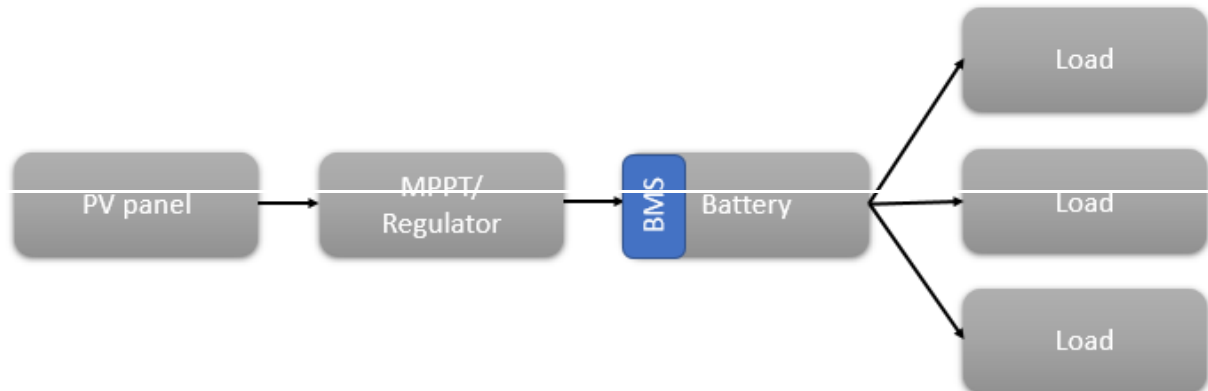

Figure 1: Basic PV system topology

2.1.1. Maximum Power Point Tracking (MPPT)

The Maximum Power Point Tracking (MPPT) is an important component within the overall solar system. This is due to the power output of the system being dictated by the component, directly impacting power. MPPTs adjust the voltage output from the PV cells by analysing the feedback from the solar system as a whole. Through continuous adjustment MPPT's maximise the output power of the solar system. There are several types of MPPTs which range in efficiency from 78-93% so MPPT selection is important.

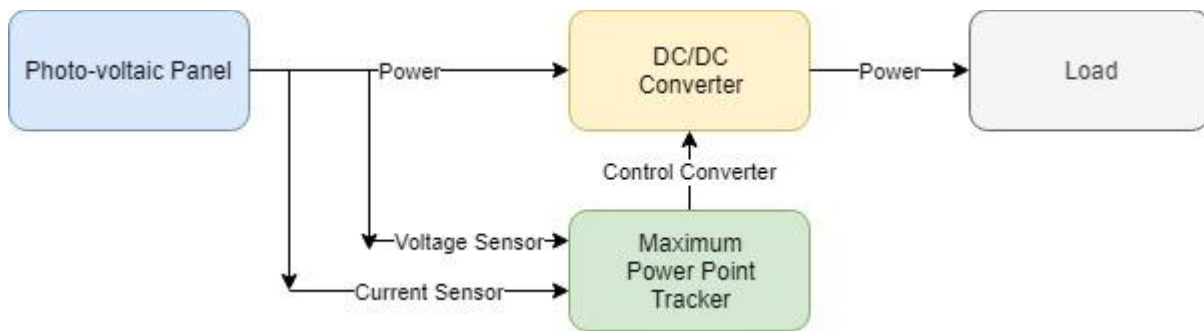

Figure 2: MPPT integrated into the solar system

MPPTs are positioned in series within the PV solar system. The MPPT works in tandem to a DC-DC converter, with the conversion being altered from the MPPT feedback. MPPTs are connected between the PV panel and the load, which requires the MPPT to be designed not only for the expected operating conditions but also the load. This load is typically battery storage or the grid, as solar energy cannot be maintained for constant demand.

In addition to multiple types of MPPTs, there are also various methods by which the MPPT can operate the DC-DC converter. These methods fall into two categories characterised by the response to external sources; simplified trends or complex analyses. Figure 3 shows the techniques and specifications for the various MMPT types and methods and the algorithms based on the output of the PV cells. (Ali Nasr Allah Ali, Mohamed H. Saied, M. Z. Mostafa, T. M. Abdel- Moneim 2012).

MPPT technique	PV array dependent?	True MPPT?	Analog or digital?	Periodic tuning?	Convergence speed	Implementation complexity	Sensed parameters
Hill Climbing / P&O	No	Yes	Both	No	Varies	Low	Voltage, Current
Incremental Conductance	No	Yes	Digital	No	Varies	Medium	Voltage, Current
Fractional Voc	Yes	No	Both	Yes	Medium	Low	Voltage
Fractional Isc	Yes	No	Both	Yes	Medium	Medium	Current
Fuzzy Logic Control	Yes	Yes	Digital	Yes	Fast	High	Varies
Neural Network	Yes	Yes	Digital	Yes	Fast	High	Varies
RCC	No	Yes	Analog	No	Fast	Low	Voltage, Current
Current Sweep	Yes	Yes	Digital	Yes	Slow	High	Voltage, Current
DC Link Capacitor Droop Control	No	No	Both	No	Medium	Low	Voltage
Load I or V maximization	No	No	Analog	No	Fast	Low	Voltage, Current
dP/dV or dP/dI Feedback Control	No	Yes	Digital	No	Fast	Medium	Voltage, Current
β Method	No	Yes	Digital	No	Fast	High	Voltage, Current
System Oscillation Method	No	Yes	Analog	No	N/A	Low	Voltage
Constant Voltage Tracker	Yes	No	Digital	Yes	Medium	Low	Voltage
Lookup Table Method	Yes	Yes	Digital	Yes	Fast	Medium	Voltage, Current, Irradiance, Temperature
Online MPP Search Algorithm	No	Yes	Digital	No	Fast	High	Voltage, Current
Array Reconfiguration	Yes	No	Digital	Yes	Slow	High	Voltage, Current
Linear Current Control	Yes	No	Digital	Yes	Fast	Medium	Irradiance
IMPP and VMPP Computation	Yes	Yes	Digital	Yes	N/A	Medium	Irradiance, Temperature
State Based MPPT	Yes	Yes	Both	Yes	Fast	High	Voltage, Current
OCC MPPT	Yes	No	Both	Yes	Fast	Medium	Current
BFV	Yes	No	Both	Yes	N/A	Low	None
LRCM	Yes	No	Digital	No	N/A	High	Voltage, Current
Slide Control	No	Yes	Digital	No	Fast	Medium	Voltage, Current
Temperature method	No	Yes	Digital	Yes	Medium	High	Voltage, Irradiance, Temperature
Three Point Weight Comparison	No	Yes	Digital	No	Varies	Low	Voltage, Current
POS Control	No	Yes	Digital	No	N/A	Low	Current
Biological Swarm Chasing MPPT	No	Yes	Digital	No	Varies	High	Voltage, Current, Irradiance, Temperature
Variable Inductor MPPT	No	Yes	Digital	No	Varies	Medium	Voltage, Current
INR method	No	Yes	Digital	No	High	Medium	Voltage, Current

Figure 3: Table of MPPT Methods and Specifications

Based on Figure 3 the simplest implementation of MPPT is constant voltage. Constant voltage

method is based on an approximation of the PV cell's maximum power across different outputs, being located approximately at the same voltage. Due to this characteristic, the voltage is set based on a VOC/VMPP ratio, commonly 76%. This allows the MPPT system to react quickly, however, due to the numerous external factors impacting the V-I curve, the MPPTs ability to adjust reduces accuracy. The effectiveness of the MPPT can be significantly impacted by temperature and power loss while sampling the VOC.

According to Figure 3, the perturb and observe or hill climbing method is the most commonly used MPPT method. It is mostly used because the system; does not rely on the PV cells; is applicable to both digital and analogue; doesn't require periodic tuning; varies convergence speed; has low implementation complexity and can operate from a voltage or current readings. The method constantly compares the instantaneous power reading with a previous power rating and adjusts accordingly. The method involves a perturbation or adjustment in the duty cycle ratio of the power converter; this adjusts the current and power. As the system observes the adjusted output power, the instantaneous power is compared to the previous reading, adjusting the duty cycle ratio until the power constantly alters around the maximum powerpoint. As it is an incremental method, it is susceptible to drastic power changes and will fluctuate around the true maximum power value.

MPPTs are a crucial component in optimising the output from the PV cells, thus the selection requirements are critical to the required output, external impact and performance specifications. Among the criteria, the output efficiency and power are highly prioritised as the MPPTs are connected to either the electrical grid, in-plant scenarios or to a power source and battery, in a self-sufficient scenario.

2.1.2. Battery

Energy storage devices, also known as batteries, are a critical component within any solar system. Batteries, in general, can be characterised as non-chargeable (primary) or rechargeable (secondary) and both types of batteries have broad applications (Recharge batteries 2019). Non-chargeable batteries are single-use and are not relevant to this discussion as solar systems utilise rechargeable batteries.

Like MPPTs there are various types of rechargeable batteries and variations have implications for the structure and performance of the solar system. Lead-acid batteries, for example, are the oldest and most common type of battery. Lead-acid batteries deliver high current at a low cost (Battery conditioning tips 2016). In contrast, Lithium-ion (Li-ion) batteries have higher energy storage capacity relative to their weight making them ideal for small and light applications. Li-ion batteries are used broadly especially in consumer electronics as they require minimal maintenance and have low self-discharge when not in use. However, since they are so widely used precautions must be taken to ensure consumer safety (Battery conditioning tips 2016) . Furthermore, Li-ion batteries reduce efficiency after 2-3 years or after a certain number of recharges. Nickel Cadmium cell (NiCd) is another common grouping of batteries which, due to Cadmium toxicity is not permitted in Australia. However, Nickel

Cadmium batteries can be recycled, recharged quickly, are capable of supplying high current and have a longer life cycle with better safety records than the Li-ion batteries (Battery conditioning tips 2016). A final common battery type is Nickel Metal Hydride (NiMH) which are relatively similar to the NiCd batteries. Although NiMH batteries have higher energy capacity and are environmentally friendly, they have a shorter life span, a small range for operating temperatures and incur a higher cost compared to the NiCd (Battery conditioning tips 2016).

Table 1: Batteries type and their Advantages and disadvantages

Battery Type	Advantages	Disadvantages
Lead-acid	Low cost High current	Low capacity Heavy
Li-ion	Low maintenance High energy storage Light in weight	Risk to safety
NiCd	High current Charges rapidly	Environmentally unfriendly Toxic
NiMH	High cost High energy storage capacity Environmentally friendly	Short life span Temperature range limitations

Due to the various types of batteries and the breadth of scope within the solar energy industry, it is unrealistic that the sector utilises a single type of battery. This research project utilises a Li-ion battery as the Lumin II MK II is equipped with a 20Kg Li-ion battery as decided by the previous AUSRT team.

2.1.3. Load

The electrical load is typically any device that consumes electricity. A load can be Direct Current (DC) or Alternative Current (AC). A load can be as simple as a battery or energy storing device or as complicated as a drive. Simple components which can function as loads include motors and lamps. Choosing a load for an electrical circuit is determined by the systems objective and the electrical circuit design and it is important to consider the power ratings between the electrical load and the electrical power supply. Motors are a common example of a load. Motors play a significant role in most scenarios as they transfer energy from one form to another and consume considerable amounts of energy. Motors are available in different sizes, shapes, ratings and operating principles which must be considered in the selection process. Despite the variety of the different types of motors, they can be categorised into two main categories; either DC or AC. In contrast to motors lamps are a simple, cheap and safe load option. They are readily available in all different sizes and shapes. Lamp specifications can be checked easily and matched to different tasks and lamp selection presents fewer risk than motor selection.

2.2. Solar cells

One of the most critical components in the PV solar system is the PV panel or the solar cells. PV cell technology uses a variety of different methods and materials. Semiconductor material, made from PN junction, is the main component in the PV panel technology. A PN junction is the cathode (N-type silicon) and the anode (P-type silicon). Electricity is generated when a photon of light passes through the junction. Photons are absorbed by the N-type and allow electrons to flow through the P-type of the cells and hence electricity is generated. The performance of PV cells has increased in the mainstream market allowing the scope of application for solar technology to broaden, including application into transport. Solar power. It is anticipated that increased usage of PV solar panels will lead to the incorporation of the technology into electrical systems and devices. Each solar system requires specific sections and components in order to provide the maximum possible energy output.

2.2.1. Solar cell varieties

The first generation of solar cells was Silicon-based and was structured as wafers whereby each wafer layer was between 160- 240um in thickness. These Silicon-based first-generation cells were single-junction cells. Single-junction cells continue to be the most widely used type of solar cell but can now use multiple and varied materials, such as polysilicon and monocrystalline silicon (Askari Mohammad Bagher, Mirzaei Mahmoud Abadi Vahid, Mirhabibi Mohsen 2015).

The second generation of solar cells was referred to as thin-film cells and continue to be used today. Thin-film cells are made by building thin film layers of semiconductor materials and layers vary in thickness from nanometres to micrometres depending on the material used. This type of solar cell has low efficiency but is flexible and for this reason, they are commonly used in commercial products handled by consumers (Altenergy 2019). This type of film includes cadmium telluride, copper indium gallium diselenide and amorphous thin-film silicon (NASA Technology transfer program 2019).

The third generation of cells comprises multi-junction cells and also has contemporary applications. Multiple PN junctions are used to simultaneously produce a greater number of electrons from a single photon. The multi-junction cells have higher efficiency than single-junction cells and can be made using Gallium arsenide wafers. Triple junction cells can also be made from indium gallium phosphide, gallium arsenide or indium gallium arsenide (Kiran Ranabhat , Leev Patrikeev , Aleksandra Antal'evna Revina, Kirill Andrianov, Valerii Lapshinsky , Elena Sofronova 2016).

Current research lends itself towards an emerging fourth generation of solar cells, focusing on low cost and the flexibility of the polymer which will aid in making thin films for use in solar cells. The emerging generation is based on the inorganic nanostructure of the solar cells. An example of this generation is perovskite solar cell. Table 2 highlights the key differences between the four generations of PV cells.

Table 2: Solar cells generation (S S Verma, 2016) and comparison between them

Generation	General	Advantage	Disadvantages	Example
First	Silicon-based Efficiency 10-20%	Low cost Long life span	Not flexible	Monocrystal Silicon Solar Panels
Second	Thin Film Efficiency 7-13%	Flexible Lightweight	Low efficiency High cost Short life span	Cadmium telluride photovoltaics
Third	Multi-junction Efficiency up to 48%	High efficiency Long life span	High cost	Indium gallium nitride substrate
Fourth	Nano solar cells Efficiency 22%	Low cost Flexible Long life span Organic	Hard to produce Low efficiency	Inorganic and organic cells

Solar cell efficiency varies according to type as indicated in Figure 4. Efficiency of solar cells is one of the most critical factors in the solar energy field. According to The National Renewable Energy Laboratory (NREL 2018), as figure 4 shows the highest known efficiency for PV cells is 46% (an updated version is released lately attached to this document). Additional, important factors are the cost and life the span of the system which is referred to in table 2.

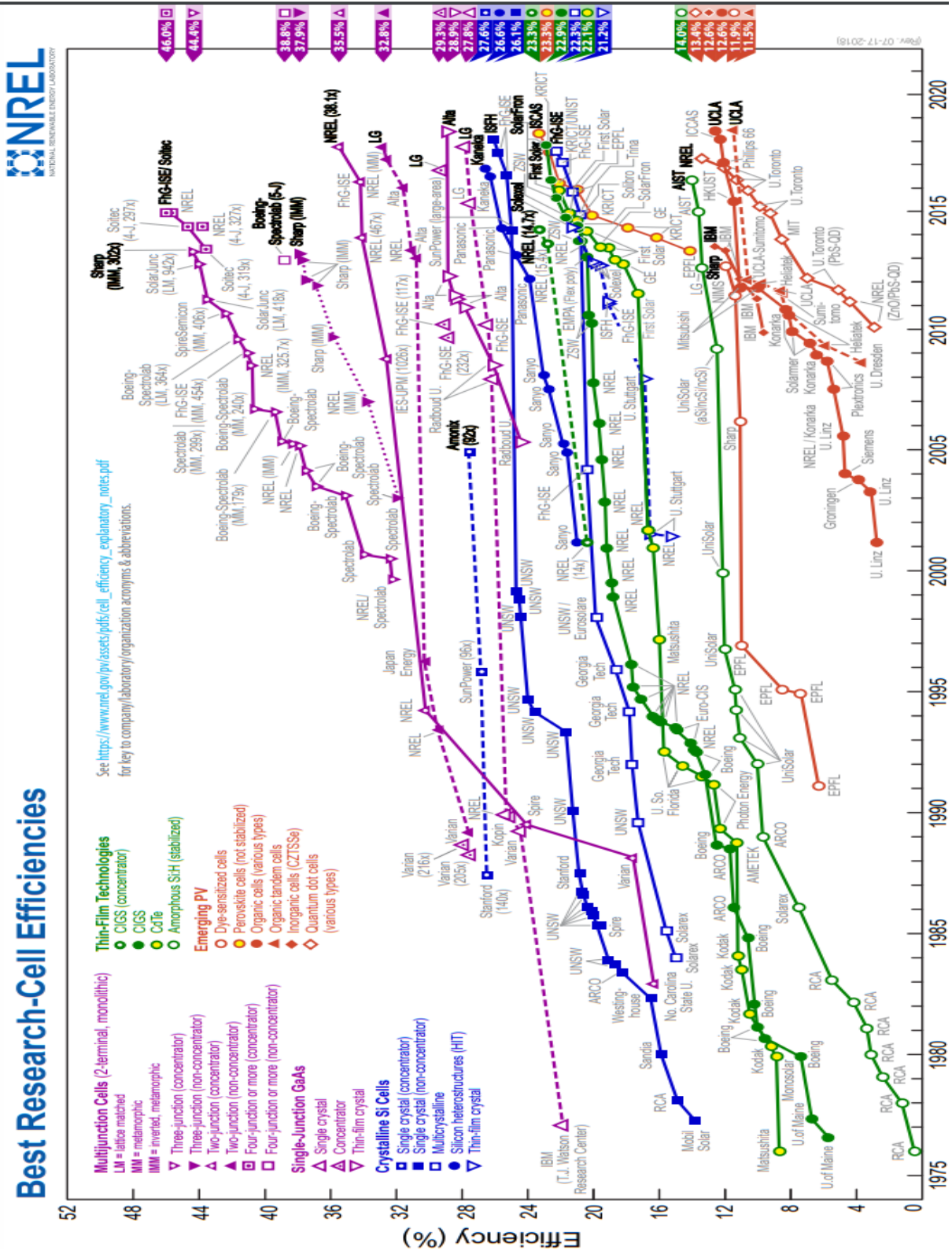

Figure 4: Best Research Cell efficiencies as of 17 July 2018 (NREL)

2.2.2. Properties and Operating Conditions

There are number of properties and operating conditions that impact the performance and efficiency of the solar cells including shading, temperature and fragility.

2.2.2.1. Shading

Shading impacts the amount of energy converted through solar panels and is thus an essential consideration for solar vehicle functioning. Figure 5 shows how solar generation systems were affected in the United States during a sun total eclipse. The event, which occurred on Monday 21st of August 2017, significantly reduced solar energy generation impacting power usage nation-wide (Michelle Bowman, Owen Comstock, Michael Mobilia 2017).

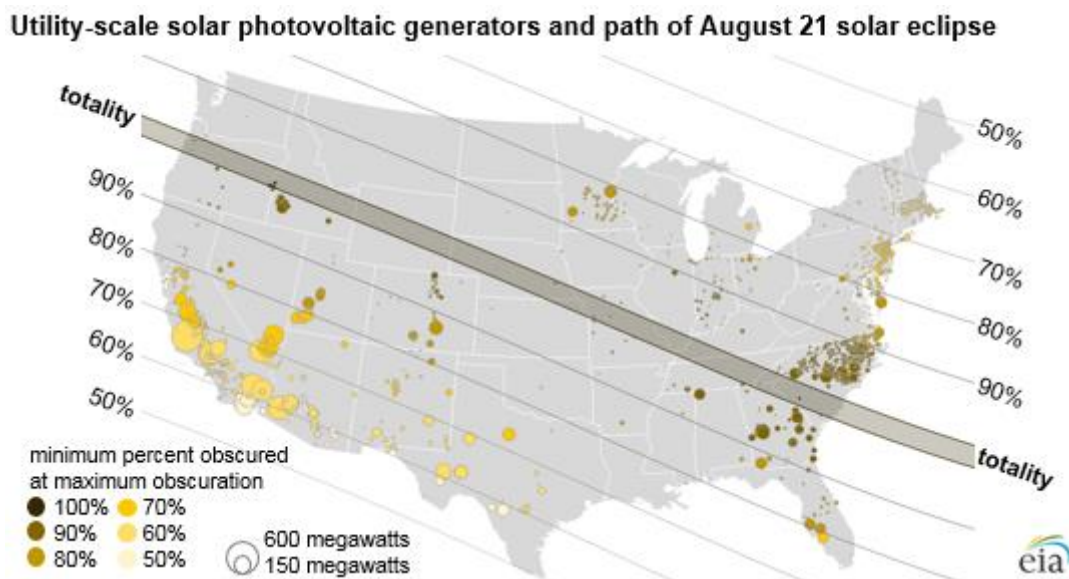

Figure 5: 2017 eclipse effect on the PV cells in 2017

2.2.2.2. Temperature

Temperature is also a factor relating to solar cell efficiency. It is important that solar cells are maintained at relatively low temperatures as high temperatures can reduce power output. Figure 6 shows how power output is reduced by increased temperatures. (V.Jafari Fesharaki, Majid Dehghani, J. Jafari Fesharaki Hamed Tavasoli 2011).

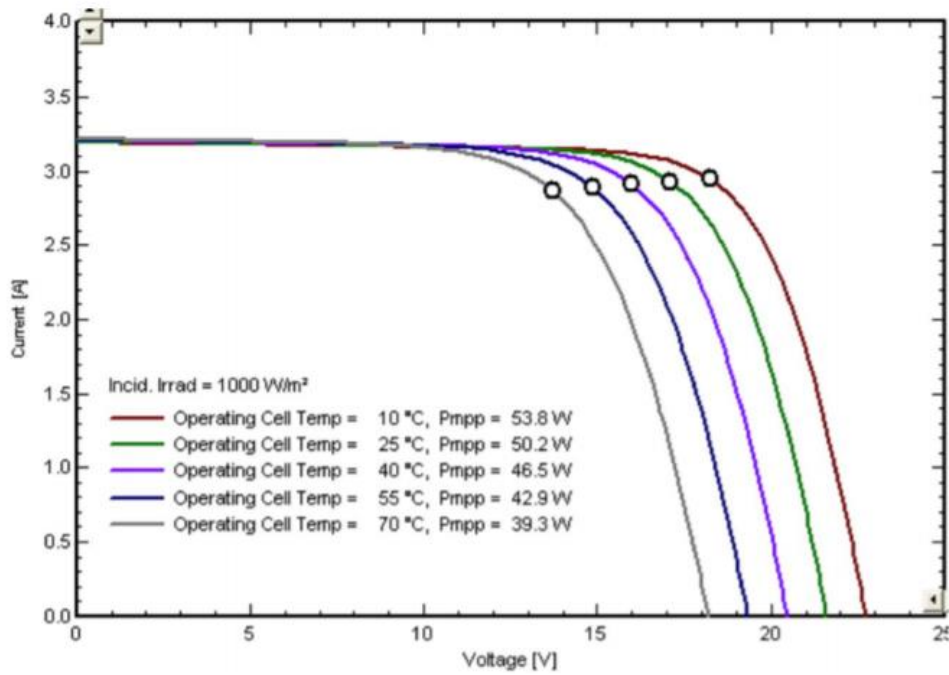

Figure 6: Output power Vs the temperature

2.2.2.3. Fragility

Solar cells are very fragile and comprised of multiple sensitive components. Solar cells can become damaged with very minimal impact or friction. Figures 8 to 10 shows some damage of the solar cells during the project.

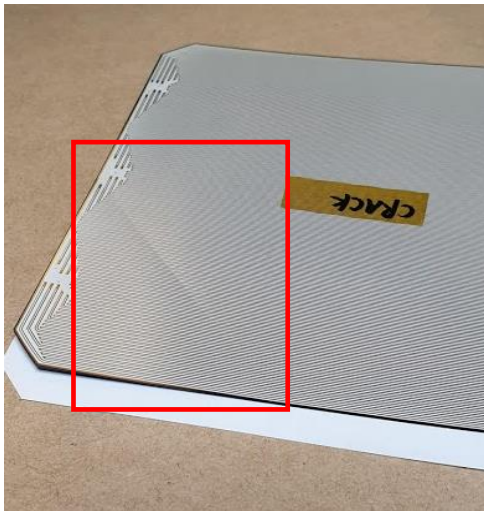

Figure 8: Sign of crack on a cell. (project picture)

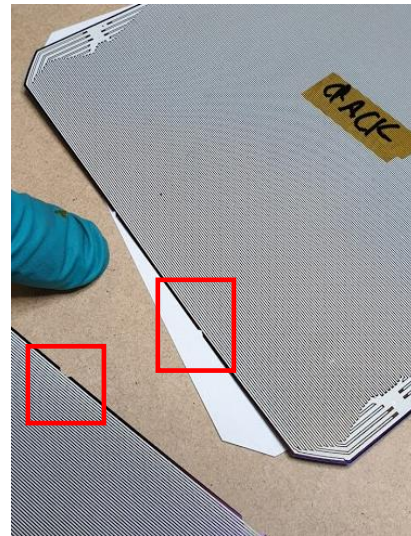

Figure 7: Sign of damage on a cell. (project picture)

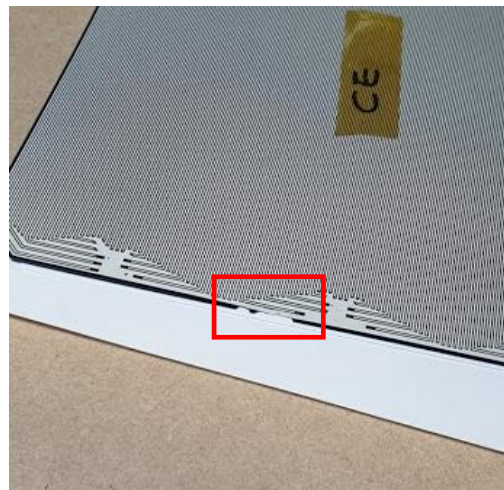

Figure 9: Sign of damage on a cell. (project picture)

2.2.3. Encapsulation

Solar cells encapsulation is the process of combining and bonding all the different material in a way that maximises strength, protection and durability with minimum reduction and impact on electrical output. The encapsulation process consists of a number of the courses and activities. Typically, the solar cells module will be exposed to a certain temperature and pressure over in a vacuumed chamber over short a period of time. This process is to ensure

the module's components joined and bonded with each other to provide the desired protection and hence the desired durability and performance.

2.3. Covering materials

Protecting fragile solar cells while maintaining their efficiency and durability requires a complex combination of different materials so that the covering material is actually a structure of its own. Various factors relating to covering materials must be considered. The materials must be sufficiently strong and rigid to support the cell structure and provide shape to the cells or the entire array. Material must be non-conductive to avoid short circuit in the array and also provide insulation from moisture, humidity and different weather conditions. Furthermore, the material must be transmissible to allow for energy and different light spectrums to pass through. Few materials meet these criteria and thus the materials used to comprise solar cell coverings are relatively consistent across the solar energy sector. These common materials used in solar cell coverings are as follows.

2.3.1. EVA (Ethylene Vinyl Acetate)

EVA (ethylene vinyl acetate), also known as Polyethylene Vinyl Acetate (PEVA), comprises one layer of the covering material structure. This ultrathin layer is a glue-like sealant which creates a clean, clear, particle-free vacuumed space to prevent contamination between layers. Once the cells undergo the process of encapsulation, it is almost impossible to remove the EVA layer without damaging the cells (PV education 2019).

2.3.2. PET (Polyester Terephthalate)

PET (Polyester Terephthalate) is a fluorine-based plastic material that is highly flexible. This non-toxic material has broad applications such as used in the manufacturing of plastic water bottles. PET is a flexible, colourless and non-conductive material and provides good resistance to impact, moisture, alcohol and other solvents (SpecialChem 2019).

2.3.3. Front Glass

The specifications of front glass used in solar cells, including the weight, density and thickness vary drastically. The front glass of solar cells typically provides most of the protection and rigidity and structure for the shape of the cell. Front glass also serves to protect the cell from UV and typically comprises the majority of solar cells weight.

2.3.4. ETFE (Ethylene Tetrafluoroethylene)

ETFE (Ethylene Tetrafluoroethylene) is another fluorine-based plastic. It has wide applications in the agricultural and automotive industries and is also known as Tefzel®. ETFE offers various properties that lend itself to application in solar cell technology including resistance to radiation and outdoor weather condition, exceptional electrical resistance, rigidity and impact strength resistance (Curbell Plastics, 2019).

2.3.5. PVDF (Polyvinylidene Fluoride),

PVDF (Polyvinylidene Fluoride), known for its electrical insulation properties, is another form of plastic widely used in wire coating for solar cells. PVDF is also resistant to chemicals, is non-flammable and has high strength and stiffness (RTP Company, 2019)

2.3.6. Back Sheet

The back sheet is the final layer of material in the PV module. This final layer provides protection, extra insulation from moisture and humidity and holds the shape for the entire module. Limited materials can be used to make back sheet. Tindo Solar uses Tedlar® TPE which is manufactured by Dupont and is known for its durability and high quality (Dupont, 2019). Brakels (2019) discusses back sheet defects in length and argues that one-third of defective PV panels can be attributed to defective back sheets. Figure 10 details common back sheet defects.

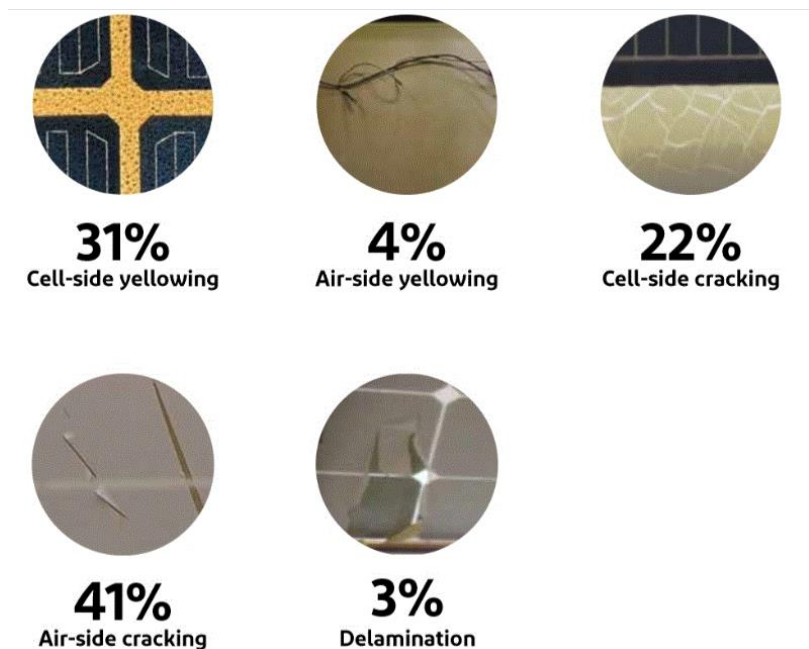

Figure 10: Samples of back sheet defects

2.4. Commercial Context

Typically, commercial manufacturing of a solar module is a standard automated process (refer to figure 11). The manufacturing line starts by feeding the machine with solar cells. The first machine will test every cell and line them up in a column according to the module length and then produce the desired number of columns. The columns are then lined up to form rows and an overall panel. The panel of cells is then placed over a back sheet and bottom layer of EVA. All cells are then soldered together in a series connection. The quality of the soldering is then tested to ensure maximum performance of the panel and the final top layer of EVA is placed. The module then undergoes lamination which is part of the encapsulation process. The encapsulation process exposes the module to a vacuum environment and high temperature which melts and adheres both layers of EVA to neighbouring layers. A thick layer of glass is placed on top and then the entire module is framed with an aluminium frame. The

module is then ready for installation into the junction box (MPPT) and a final inspection before it leaves the production line (refer **Figure 12**).

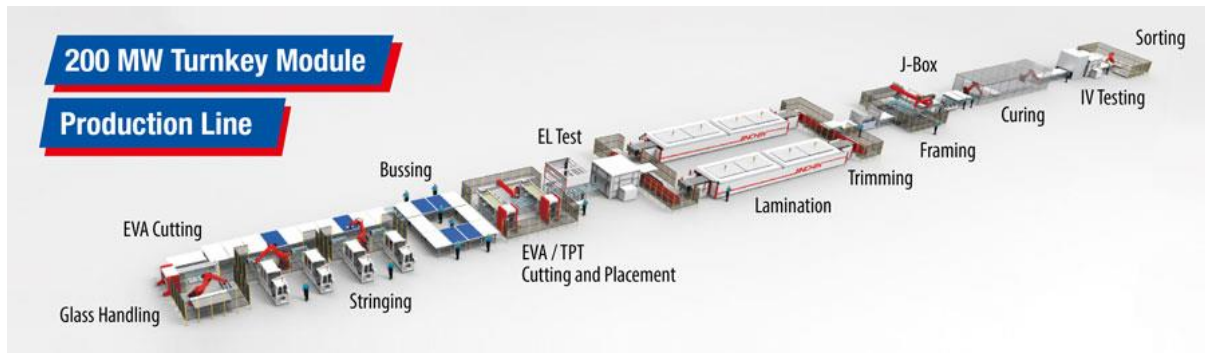

Figure 11: solar cells manufacturing (JBAO 2019).

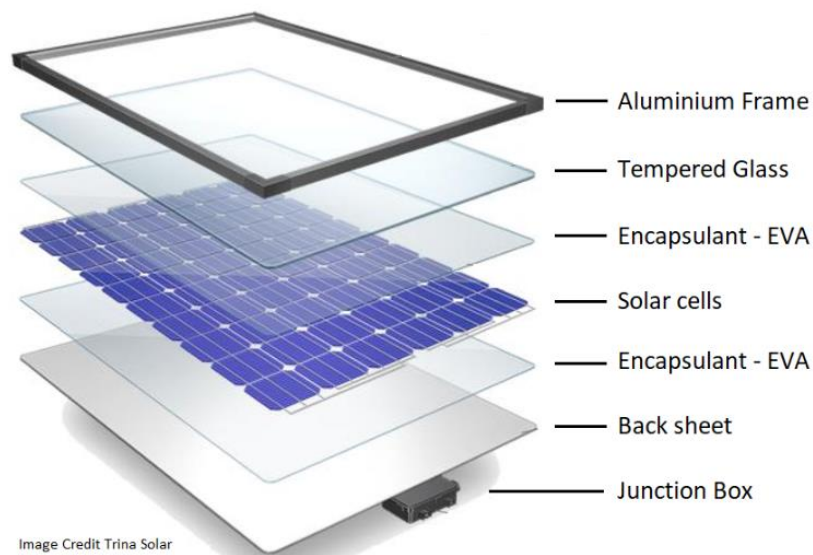

Image Credit Trina Solar

Figure 12: Commercial view of solar panel construction (Jason 2018)

2.4.1. Lamination

The solar cell encapsulation process can be referred to as bonding. Lamination is a multi-step process in which three different elements (heat, suction and pressure) are applied to the module to achieve the desired bonding. The three elements and the duration of the process vary based on the layers of material used to construct the solar module. The first element is heat which is maintained constant throughout the whole process. The second element is vacuum suction to remove all gas from between the layers of the module. The third element is the application of pneumatic pressure on the module. Together these elements achieve lamination, an irreversible process. Any attempt to reverse lamination will cause damage to

layers of the module. Figure 13 details the display of the laminator machine. The standard lamination procedure for a commercial panel involved 98 KPa air vacuum, a temperature of 142 degrees Celsius and slow, fast and medium pressure was applied.



Figure 13: The lamination parameter for commercial module

2.4.2. Durability

There is a profound difference between the array used in this project and typical commercial arrays. The project array aims to obtain the maximum amount of energy in a short time, unlike commercial modules which are designed to harvest the same amount of energy for up to 20 years. The panels used in this project are significantly lighter than commercial panels. The commercial size panel can exceed 20kg in weight. The commercial size panel protects with several layers of material to provide strength and durability whereas the project panels are protected with a single ultra-thin film. In addition, the project panels have blue cells whereas the commercial panels are typically black. All these factors contribute to the durability of the project panels being substantially less than commercial panels.

2.5. Solar Racing Vehicles

Solar racing vehicles are powered and operated by solar energy. Typically, solar vehicles are equipped with solar cells to harvest solar energy, a battery for energy storage and a motor to convert the electrical energy to mechanical energy. The motor also moves the vehicle. Compared to other solar energy applications, solar racing vehicles require large amounts of energy to be harvested quickly. Commercial solar panels are covered with thick and heavy layers of glass and covering materials for long term durability, but the weight makes these panels impractical for solar racing vehicles. A lighter option of panel that maximised short term output was required. The AUSRT team used a novel and unique methodology for solar panel construction in their solar racing vehicle which competed in the 2019 BWSC 2019. The Lumen II MK II used solar cells with plasma treated films without a top layer of EVA.



Figure 14: Lumen II Mk II – Solar race vehicle

2.6. Research Gap

This literature review highlights the degree of variation and complexity involved within each of the components that comprise a solar system. Solar racing vehicles seek to achieve specific goals for which conventional solar cell methodologies and materials are not ideally suited. This project identifies a gap in how such methodologies and materials can be adjusted to maximise solar vehicle performance and output. Specifically, the structure and encapsulation process for covering materials of solar cells used in the racing vehicle has not been thoroughly explored in the existing literature.

3. Aim

The aim of this project is to determine the most efficient covering material structure and encapsulation process that will maximise the power output for solar cells used in a solar racing vehicle.

4. Method

The method of testing solar cell covering materials in this research project involved five trials. Trials used different covering material structures which varied in material and encapsulation processes. Initially, it was planned that testing would occur exclusively outdoors in order to assess degradation, weather resistance and energy output of the solar cells. However, due to unforeseen production and design challenges as well as time restraints led to adjustments in the project plan. In summary, testing involved one outdoor trial and four indoor trials.

4.1. Outdoor Condition

Outdoor testing primarily aimed to study solar cell degradation and weather resistance. It was anticipated that solar cells would degrade with time and efficiency of output would decrease. Conventional modules typically comprise a covering material structure with no upper EVA layer and no front glass layer. These specifications are designed to protect cells from degradation and weather exposure. For this reason, the modules tested in the outdoor condition have no upper EVA layer and no front glass. In place of the front glass, an ultra-thin layer of ETFE and PVDF film were used respectively in the two modules.

The outdoor trial tested two 15-cell PV panel modules. One module was covered with PVDF (refer Figure 16) and the other was covered in ETFE (refer Figure 15).

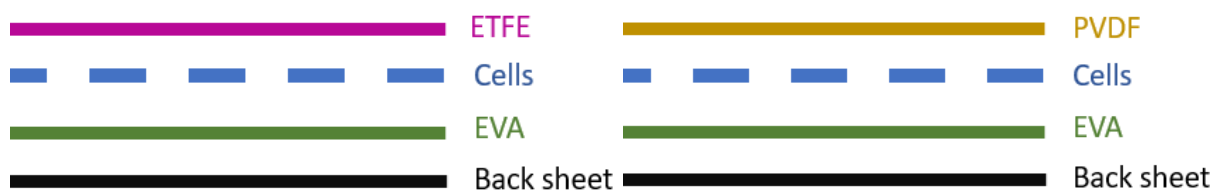

Figure 15: PVDF Module

Figure 16: ETFE Module

Outdoor testing equipment was custom-designed and assembled so that it would account for the desired variables including temperature, voltage, radiation, time, date and humidity. The outdoor testing site was located at the Tindo Solar facility in Mawson Lakes, Adelaide, South Australia. The modules were exposed to the outdoor conditions for 4 days before weather damage concluded the trial. Figure 17 shows the electrical layout of the custom-built testing equipment.

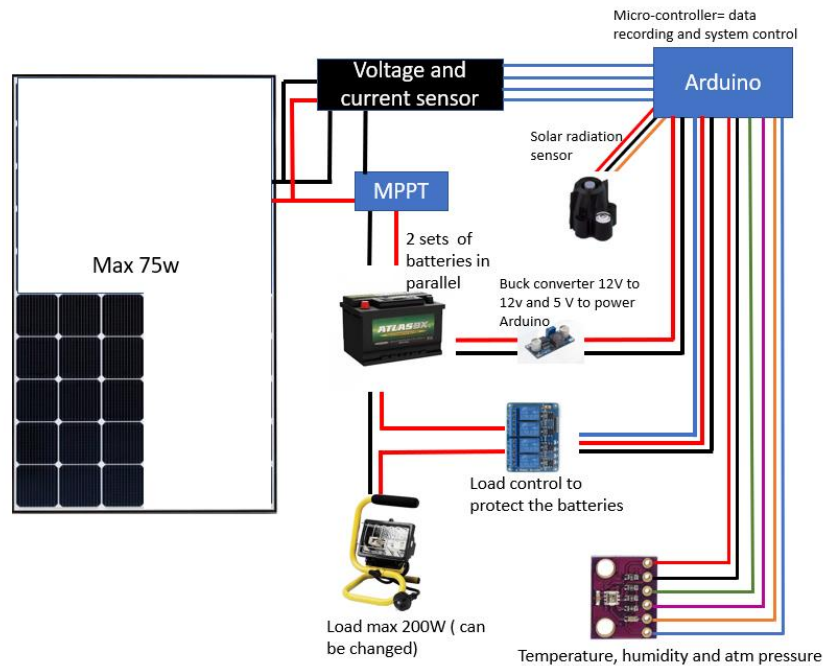

Figure 17: Diagram of the electrical circuit for the outdoor testing

4.2. Indoor Condition

The method for the indoor condition was directly impacted by the results of the outdoor condition testing. Specifically, weather damage required new approaches for the development of the covering materials to maximise the use of time and resources. Details of which are elaborated upon in subsequent sections of this report.

The indoor condition aimed to test the condition and the performance of the solar cells before and after different types of encapsulation processes. Indoor testing was conducted at Tindo Solar facility in a space specifically designed for solar cell testing. The testing equipment for the indoor condition was owned by Tindo Solar and operated by trained Tindo staff members.

Electroluminescence testing (EL testing) was used to test the quality of the cells before and after the lamination and the effect of the lamination process on the modules. SPi-Simulator 4600 simulates solar radiation, measuring the module power output in order to assess the overall performance of the solar cells. A limitation of the simulator is that it needs a minimum number of cells to provide minimum without which the simulator will not provide accurate results.

Four trials were conducted in the indoor condition as part of a dynamic process of testing, reviewing, adjusting and re-testing the covering materials.

5. Project Management

Project planning was crucial to ensuring that this project was completed according to its aim, as previously defined. Management of this project involved managing project

constraints, defining the Work Breakdown Structure (WBS) and conducting a project risk analysis. A Gantt chart was developed for this project in order to allocate time to major tasks and deliverables within the project.

5.1. Project Constraints

This project involved various limitation and constraints that needed ongoing management and problem-solving. These constraints included:

5.1.1. Testing Conditions

The university could not provide adequate testing locations and so ongoing communication was required with Tindo Solar in order to facilitate testing at their facility. Furthermore, the university did not have access to testing equipment. This is likely due to the advanced technology and high cost of the equipment. Fortunately, Tindo Solar was willing to provide the equipment, material and expertise for the entire testing process. This presented some limitations in terms of access to and control of testing conditions.

5.1.2. Safety

It was a requirement that the university safety regulations were followed at all times. This required ongoing consideration throughout the project. An example of a limitation relating to safety was that testing could not be conducted on the roof of university buildings even though the environment suited the project.

5.1.3. Time Limitation

This project was limited to a period of one academic year. It was essential to complete the project within this time frame. This is a significant project limitation given that PV module testing typically requires a period of over 20 years. It is a strong recommendation that future projects understand the challenges associated with the time limitation of one year, especially in light of the numerous challenges and limitations that emerged throughout the project.

5.1.4. Resources

Resources for this project needed to be procured in advance with an understanding of lead times. Delivery delays significantly impacted the project. For example, AGC Chemical films took several months to be delivered, arriving in the last month of the project. The project also had limited resources and budget and it was not possible to exceed the project budget or access additional funding. This project required the generosity of AGC Chemical and Tindo Solar without whom the project could not have proceeded. Notably, travel costs to the Tindo Solar facility were paid at the expense of the researcher so that the project budget could be maximised for equipment and supplies.

5.2. Budget

The budget for this project was limited. Refer Appendix # for a breakdown of expenditure including a comprehensive list of equipment and tools.

5.3. Work Breakdown Structure (WBS)

A Work Breakdown Structure (WBS) was developed to outline the major sections of the project including the project deliverables, work structure, resources and risk analysis. The WBS was developed at the project outset and then reassessed as the project progressed.

5.3.1. Project Deliverables

- **Project Definition Statement and Plan**
This document summarised relevant research included a literature review and provided an overall project plan.
- **Mid-Project Report**
This document highlighted the progress and delays of the project, testing, research and future plan.
- **Seminar**
The seminar involved a project showcase presented to a panel of academics in the field of mechanical engineering.
- **Encapsulation method validation**
The method best suited to the solar vehicle (Lumin II MK II) was determined and applied on all the arrays. The vehicle then participated in the Bridgestone World Solar Challenge. The solar arrays produced the maximum amount of energy available and resisted all weather conditions so that the vehicle successfully completed the 3000Km journey for the first time.
- **Final Report**
The document showed the results of the project.

5.3.2. Work Structure

The Work Structure for this project was as follows:

- Submit the project proposal document to the university
- Submit the literature review document
- Investigate the effect of covering materials in general
- Initial communications and meetings with Tindo Solar and AGC Chemical
- Determine the procedure for the outdoor condition testing
- Submit the procedure
- Procure resources
- Build the solar system for the outdoor condition
- Perform outdoor testing
- Identify and analyse the results of outdoor testing
- Determine procedure for the indoor condition

- Perform the first indoor trial at Tindo Solar and document results
- Perform the hydro test at the university and document results
- Analyse and compare results of the first indoor trial at Tindo Solar and hydro test at university
- Submit the mid-project report
- Determine the procedure for the second indoor trial at Tindo Solar and document results
- Analyse the results
- Write and submit a conference abstract
- Present the results at ECMS seminar
- AGC films received and used in subsequent indoor testing trials
- Determine the procedure for the third indoor trial at Tindo Solar and document results
- Analyse the results
- Determine the procedure for the fourth indoor trial at Tindo Solar and document results
- Analyse the results
- Submit the final report
- Submit Research Paper
- Project closeout form

5.3.3. Resources

- Online
- Literature
- Solar Car (Lumin II MK II)
- Lecture notes
- Experiment knowledge and trial results

5.3.4. Risk Analysis

To ensure that the project was conducted in a safe manner, a risk and safety analysis was conducted. This process highlighted major risks within the project, while also allocating a safety measure to each risk. The overall risk determined was measured based on Table 4 and 5 below.

Table 3: Risk Analysis

P r o b a b i l i t y	Severity					
	1	2	3	4	5	
	5	High	High	Extreme	Extreme	Extreme
	4	Moderate	High	Extreme	Extreme	Extreme
	3	Low	Moderate	High	Extreme	Extreme
	2	Low	Low	Moderate	High	Extreme
	1	Low	Low	Low	Moderate	High

Table 4: detailed risk analysis

Risk	Effect on the project	P	S	Risk Level	Mitigation Strategy	Prevention Strategy	Resulting Risk Level
Incorrect component selection	The component will need to be reordered	2	4	Moderate	Adjust Testing to accommodate new component if applicable	Check all ordered components before the transaction	Low
Damaged component	The component will need to be replaced	2	3	Low	Check components before Testing	Have spare components of any liable components	Low
Prototype failure	Another prototype will be needed for testing	1	5	High	Check prototype during testing	Design the prototype procedure to minimise failure	Moderate
Prototype construction exceeding available funds	Some components ordered will not be available	2	3	Moderate	Only buy components when necessary, and in order of priority	Plan full project and spares for components before component ordering (borrow)	Low
Loss of data files	Previously completed	3	2	Moderate	Keep constantly saving while	Save multiple copies, keep	Low

throughout the Project	sections need to be redone				working	older copies and save on cloud storage	
Team members unable to adhere to Gantt Chart	Project becomes behind schedule	1	3	Low	Adjust workload and construct multiple small goals	Create the Gantt Chart with reasonable time estimates, incorporate slack time	Low
Specialised components not manufactured in Time	Testing behind schedule	3	2	Moderate	Order components with in advance, with sufficient lead time	Organise with workshop ahead of time, allocate manufacturing time, constantly check manufacture progress	Low

6. Design of Outdoor Testing Equipment

The custom-designed outdoor testing system was designed and assembled at the University of Adelaide. It utilises an IC SVP 1020 as part of the MPPT circuit, whereby IC indicates an integrated circuit. The IC SPV 1020 functions as a boost regulator for the solar system and its working range of 10V to 33.5 VDC determines the working range of the overall solar system. Notably, the equipment did not work according to the datasheet specifications which stated a start-up voltage of 6.5V. The MPPT will boost and regulate the power output for 15 cells to 12V and simultaneously charge the batteries. Energy, stored in the batteries is used to power 2 sets of halogen lamps (load). If the batteries reach full capacity they discharge using the lamps. The lamp will consume 400W while the maximum solar output is 300W to ensure the batteries never reach maximum capacity. The system is designed to capture the desired data parameters for the test. Analysing these data will determine which module is performing better within the test condition. The system records the following data using different types of sensors:

1. Temperature and humidity using BME280
2. Date and time using RTC
3. Voltage and current using Voltage and current sensors
4. Irradiation using solar irradiation sensor

The control system box for the outdoor testing equipment contains the microcontroller, electrical current and voltage sensor, MPPTs, relays and other supporting components. The MPPTs were designed and manufactured at the University of Adelaide by Noirio Itusami. In

conjunction with the batteries, the system is also equipped with buck converters that can power the microcontroller even in the absence of sunlight. The battery box contains four 12V batteries. The batteries are set up in pairs in parallel connection with one pair for each MPPT. The parallel connection provides a greater capacity for energy storage, avoids overnight power depletion and subsequently provides longer-lasting functionality. Figure 17 shows the outdoor control system box. Figure 19 shows the four 12V batteries, notably in this image they are set up in series whereas they were set up in parallel for testing. Figure 17 shows the entire circuit and the connection. Figure 20 shows a sample of the parameters of the system that were recorded during the operation. Parameters were recorded and stored on an SD card in text file format and attached to the Arduino shield. To access the data the SD card was removed from Arduino and plugged into a computer. The Arduino measures the parameters by utilising:

- an additional shield board that collects voltage and current data which is then displayed in the serial communication window
- a temperature sensor
- an irradiations metre (accessed from the university labs)
- an MPPT that boosts and regulates the solar cells power output

As per the aforementioned Figure, 15 and figure 16 the structure of the two modules used in the outdoor test are ETFE/ Cell/ EVA/ Back sheet and PVDF/ Cell/ EVA/Back sheet.

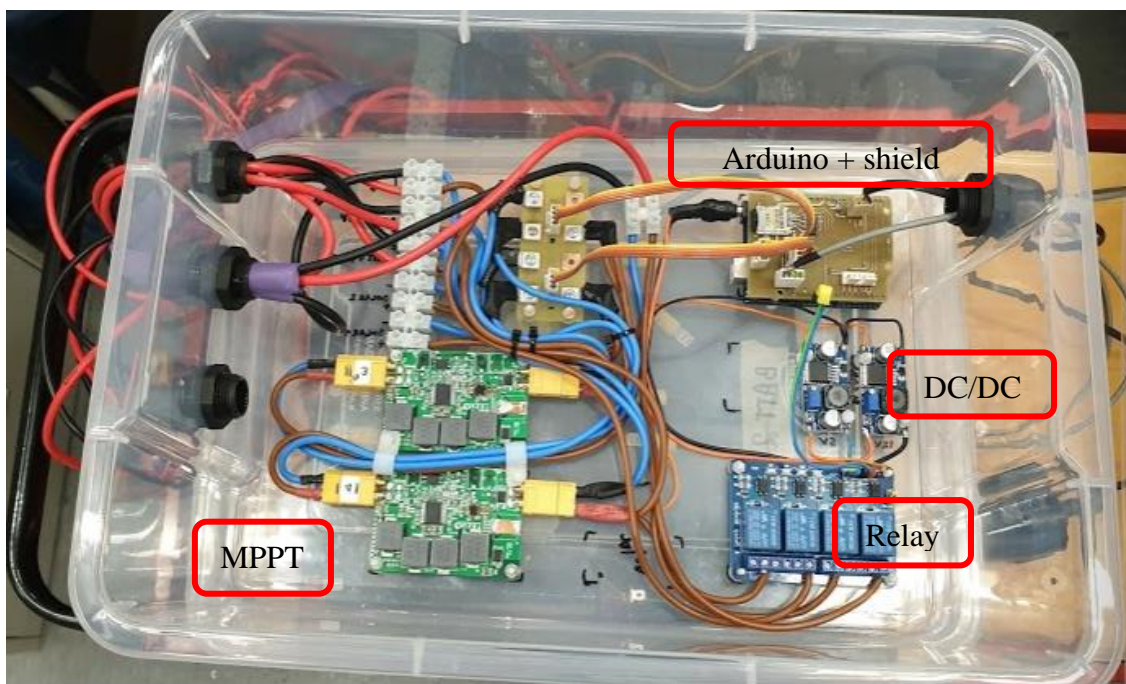

Figure 18: Control system components - (project picture)

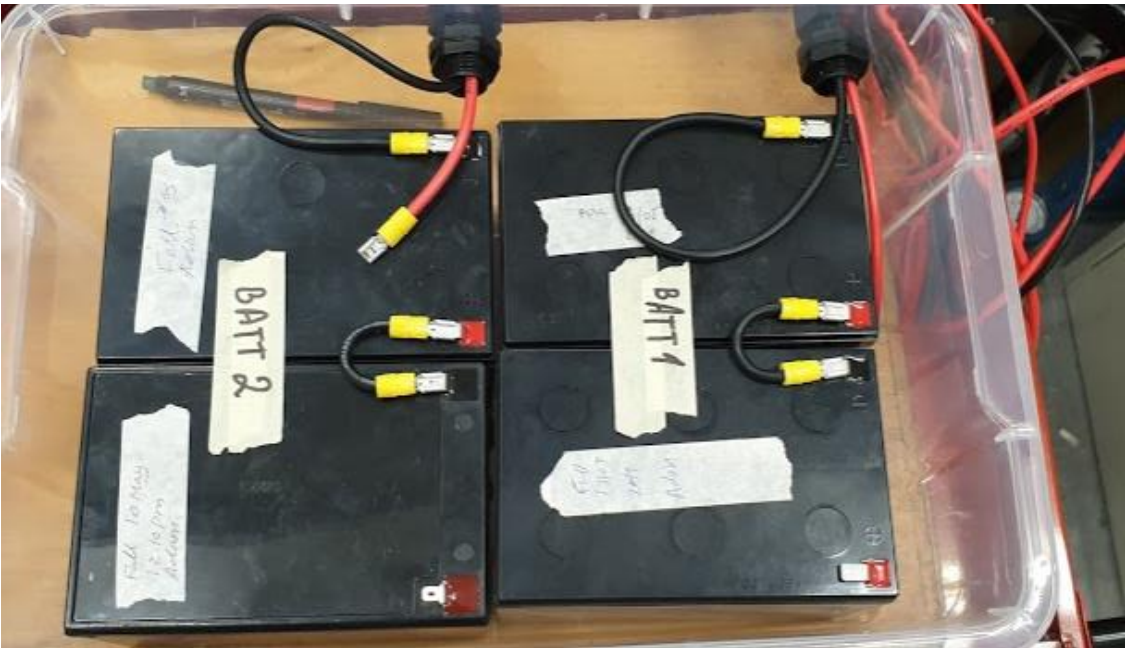

Figure 19: Battery box – (project picture)

```

9.48250,0.02640,0.25000,9.49500,0.03880,0.37000,12.32,12.29,891.27,20.64,62.40 *
150 * Thursday 30.05.2019 -- 10:44:27
9.47125,0.02640,0.25000,9.47250,0.03880,0.37000,12.27,12.29,891.02,20.71,64.23 *
151 * Thursday 30.05.2019 -- 10:44:31
9.47500,0.02640,0.25000,9.48625,0.03920,0.37000,12.27,12.29,888.39,20.73,64.01 *
152 * Thursday 30.05.2019 -- 10:44:33
9.47250,0.02640,0.25000,9.48375,0.03880,0.37000,12.27,12.29,885.52,20.78,64.76 *
153 * Thursday 30.05.2019 -- 10:44:36
9.47125,0.02640,0.25000,9.48250,0.03880,0.37000,12.27,12.29,888.39,20.84,64.76 *
154 * Thursday 30.05.2019 -- 10:44:38
9.46750,0.02640,0.24000,9.47750,0.03880,0.37000,12.27,12.29,882.64,20.90,66.32 *
155 * Thursday 30.05.2019 -- 10:44:42
156 * Thursday 30.05.2019 -- 10:44:44

```

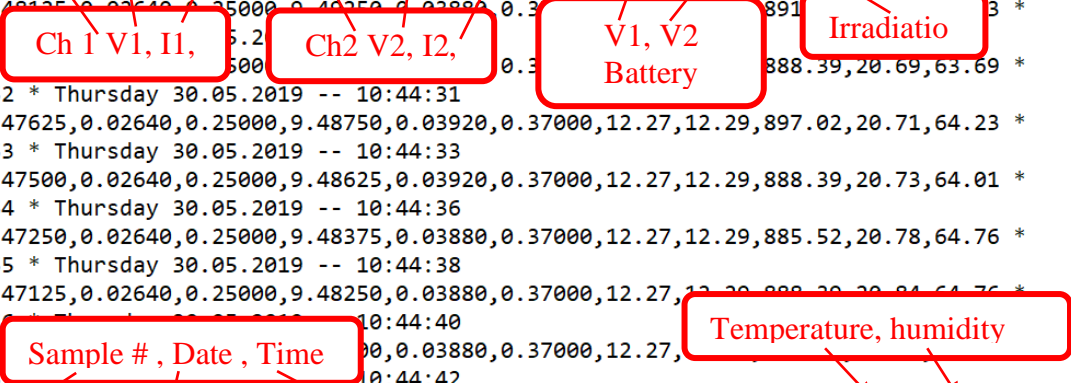

Figure 20: System recorded data

Several factors relating to the design and implementation of the testing equipment system were considered. Firstly, the project began using Arduino UNO as a microcontroller. However, Arduino UNO generated unreasonable error messages including error in the serial communication window. This was possibly due to the volume of data however it is unclear because it was measured as working at only 89% capacity. After replacing the UNO board with an Arduino Mega board these problems were resolved and the codes worked without issues. This issue did not significantly hinder the project. Secondly, Arduino boards are equipped with

an internal time clock, during the project it became apparent that these internal clocks are not accurate over long periods of time. This internal clock issue did not significantly hinder the project. Thirdly, as previously mentioned the MPPT datasheet stated the working range as being between 6.5V to 40V while testing indicated that the lowest range achieved was 10V. This meant that the MPPT never turned on due to insufficient voltage input. This issue significantly impacted the project and contributed to the outdoor condition being stopped. This challenge could have been resolved by using a greater number of cells in the array (minimum 30 cells) which would permit a higher output and in turn effectively trigger the MPPT. This option was not utilised due to limited budget and water damage.

A final contributing factor was water leakage and damage to the solar modules. It rained heavily during initial days of the outdoor testing condition, water leaked to the array causing a short circuit and damaged the modules beyond repair. Upon inspection, it appeared that the top sheet had been pierced. During the encapsulation process, Tindo Solar correctly recommended using a Teflon mesh sheet, the purpose of which was to prevent wrinkles from forming. Wrinkles cause air to become trapped between the cell and the top sheet, preventing uniform vacuum which undermines the efficiency of the module. Wrinkles start to form when the module temperature reaches 70 degrees Celsius. Figure 23 and 22 show an example of wrinkles. While the use of the Teflon mesh did prevent wrinkling its usage during the encapsulation process caused the module to be pierced resulting in the water damage. Such piercing is inevitable when using the Teflon mesh.



Figure 22: Sign of wrinkles (project picture)



Figure 21: Sign of wrinkles (project picture)

7. Testing

There are a number of tests which can be conducted to assess solar cell functioning. These tests are useful to determine the efficiency, performance and condition of solar cells and compare cell performance to manufacturing specifications. This project utilised the following tests.

7.1. The Dark IV test

The dark IV test is the most commonly used solar cell test. It measures the voltage and current of the solar module to produce an exponential curve to determine the characteristics of the PV cells. The curve can be used to analyse the electrical properties of the solar module. The test cannot provide information about the short circuit current but it can define other parameters. This test was not used in the research project as the researcher could not access the devices.

7.2. Spi-Sun Simulator™ 4600SLP

The PV panel simulator is a solar industry-specific device that mimics a sun's UV. It tests the PV panels performance to ensure it is assembled in accordance with specifications. The simulator has an integrated electrical device and maximum power point tracing which together function as a load to the panel. Simultaneously it measures the maximum output of the PV Panel. It provides a known input of UV and measures the output to determine panel efficiency. The simulator produces a document that includes all relevant data from the simulation. Spi-Sun Simulator™ 4600SLP (refer Figure 24) is the simulator used at Tindo Solar and it is capable of exposing the panel to radiation between 400 -1100 nm with 2% accuracy. This testing was conducted in an indoor Tindo Solar lab.



Spi-Sun Simulator™ 4600SLP A PHOTOVOLTAIC MODULE TESTER



Figure 23: Spi Sun simulator (from the simulator manual attached in appendix)

The PV panel simulator is a device issued in labs to test the PV panels performance to ensure the assembled PV panels are with accordance to the specification and within the PV module specifications. The simulator has an integrated electrical device called Maximum power point tracing which act simulator to a load to maximise the output of the PV Panel. Spi-Sun Simulator™ 4600SLP is used at Tindo Solar. The simulator is cable of exposing the panel to irradiances from 400 -1100 nm with 2% accuracy.

7.3. Electroluminescence (EL) testing

Electroluminescence testing or EL testing is utilizing the electroluminescence phenomena to test solar cells. The EL testing is different from the final check using the Spi-Sun Simulator™ 4600SLP and cannot substitute simulation testing. It is known that PV cells are a reverse Light Emitting Diodes (LED). That is to say that when an electrical current goes through LEDs they emit light, PV cells are just the same but in reverse. Typically, solar cells are exposed to a range of light spectrum and then produce an electrical current. EL testing takes advantage of this phenomena by passing an electrical current through solar cells and measuring the small amount of light they produce as a result. “EL imaging is used to test the manufactured solar modules for cell inherent defects, such as micro-cracks, debris, bad soldering, and for instance to detect an inactive string inside a solar module. EL imaging is becoming more and more important for quality testing of solar cells, as the defects can be severe but are not visible to the naked eye” (Sinovoltaics Group, 2019). Figure 25 is an example of how EL testing reveals damage within cells.

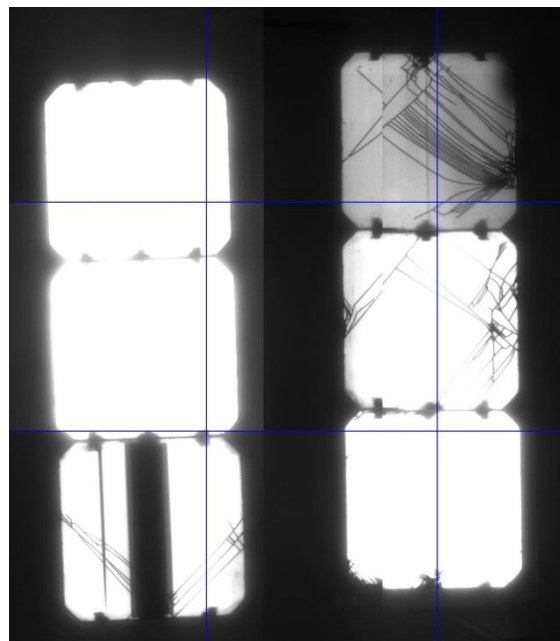

Figure 24: Example of EL testing showing damaged cells. (project picture)

7.4. Hydro Testing

Hydro Testing is used to verify the effectiveness of modules adhesive and insulation. Hydro Testing involves submerging the modules in water (35cm in depth) for 20 minutes and observing for any water leakage. The main concern with Hydro Testing is if leakage occurs from the edges of the submerged sample as this will indicate that the lamination method was insufficient to protect the module from moisture etc. Figure 26 shows a submerged sample module whereby the dark spots indicate leakage.

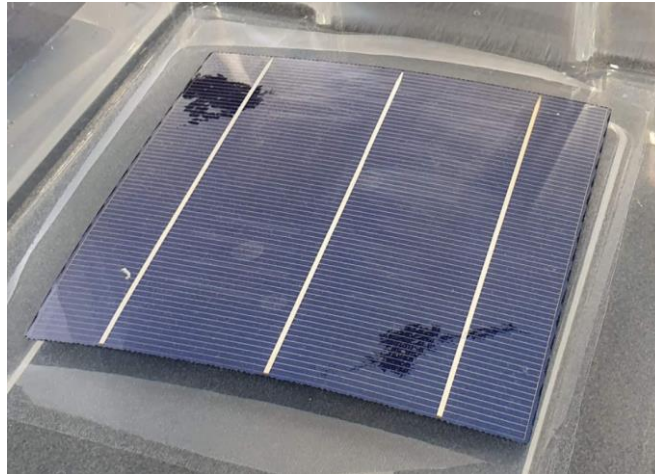

Figure 25: 20 minutes after module #1 in the hydro test. (project picture)

7.5. MPPT Testing

Norio Itusumi has designed a custom-designed MPPT which acts as MPPT and load for the solar cells to determine the maximum output of the module. The procedure for Norio MPPT testing involves taking the module outside and exposing it to direct sunlight. Measures of the maximum power are immediately available. For accurate results, it is recommended that irradiation should also be measured simultaneously.

7.6. Outdoor Testing

Outdoor testing aimed to assess the impact of the environment on the solar modules. Table 7 details the tools used for outdoor testing.

Table 5: Parts and (equipment used for the outdoor testing)

Item Name	Item Description
Housing	Arlec 500W Portable Halogen Work light
Lamp	Philips 50W G6.35 Essential Halo Halogen Globe - 2 Pack
Socket	holding socket connecter
Temperature sensor	Adafruit BME280 Temperature Humidity Pressure Sensor
Battery	12V 12Ah SLA Battery
Sensor	Solar Radiation Sensor
Relay	4 channel relay
Buck converter	buck converter
SD card reader	SD card reader
SD card	SD card 32Gb
Safe box	Excalibur 6 Outlet Outdoor Safety Box
Gloves	Sabco Medium Purple Nitrile Disposable Gloves - 100 Pack
Isopropyl Alcohol	Diggers 125ml Isopropyl Cleaning Alcohol
damp free	DampFree 36g Mini Dehumidifier Sachets - 3 Pack
cloth	Morgan Microfibre Cleaning Cloth - 20 Pack
RTC circuit	Real Time clock circuit
MPPT	The Solar car MPPTs were used (provided by Norio)
Arduino Board	Arduino Mega board.
Current & voltage Shield	Made by Norio (drawing attached)
Cables wires and plugs	Other accessories provided by Adelaide university lab

7.7. The rationale for Test Samples

Following the results of the one trial in the outdoor testing condition, it was important to identify problems and revise the approach to constructing the modules for the samples used in the indoor condition. There were four trials testing samples in the indoor condition with results of each trial informing how samples were adjusted in subsequent trials.

7.8. Plasma Treatment

Samples for the final indoor trial were plasma treated based on recommendations from trained staff at AGC Chemical. Plasma treatment works by ionizing the surface of the film with charges to increase its ability to accept, bond and adhere to other surfaces including the top film in a solar cell. The plasma treatment utilizes either a single gas or a mixture of gasses in

a vacuum space before applying it on the desired surface to achieve bonding. This approach can be used for many materials and composites surfaces in a variety of applications.

Plasma treatment technology in solar cell films in this research project significantly improved adhesiveness and bonding properties. AGC Chemical provided three 15M rolls of ETFE films plasma-treated on both sides; ETFE 50, ETFE 25 and ETFE 12.5 respectively. The approach also improved the transmissibility of the films as detailed in Figure 27 and Figure 28.

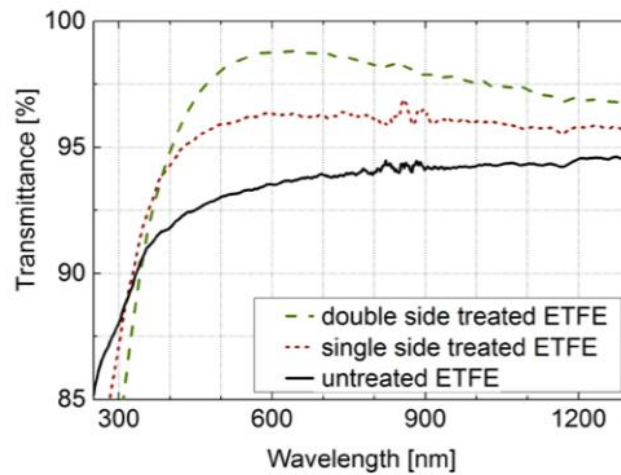

Figure 5. Transmittance of ETFE cast film, single side and double side treated ETFE with thin sputtered SiO₂ top coat [16].

Figure 26: The plot above show how the double-sided plasma treatment increases the transmittance 5% more than not treated.

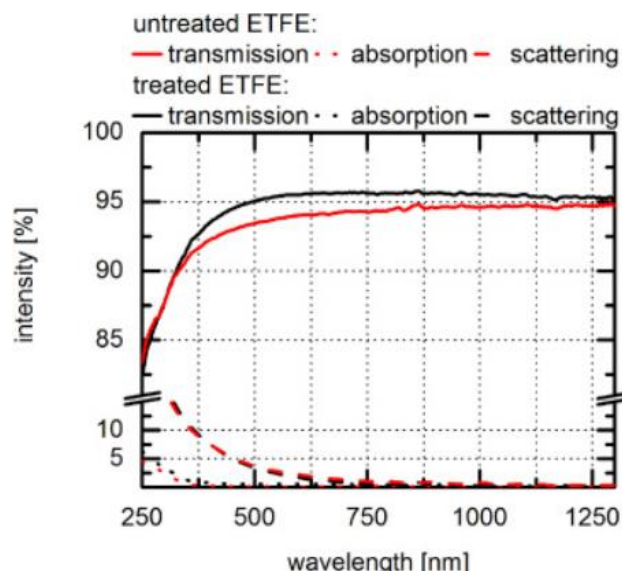

Figure 27: This plot shows the difference between the treated and untreated film in three properties, transmission, absorption and scattering.

8. Production

Production was the process of selecting the materials and methodologies to create different samples for multiple testing trials. The sample modules for both the outdoor and indoor conditions had to meet certain specifications in order to achieve the aim of maximising power output over a short period of time. These specifications included:

- Electrical isolation
- Water and humidity resistance
- Resistance to short-term exposure to UV
- Lightweight
- High transmissivity
- Flexibility
- Adhesiveness
- High resistance to impact
- High tensile strength

Finding materials that combined to maintain these specifications was challenging. Thus each sample created was made by utilising different combinations of materials, different methods for encapsulation and a different size of solar arrays.

8.1. Materials

Different materials were used throughout the production of the sample cells and modules. Figure 30 shows the bare solar cells with a bottom EVA and back sheet is in the process of being cut to the sample size.

A general consideration when using films is to ensure the correct side of the film is used as one side is adhesive and one is not (refer to Figure 29).

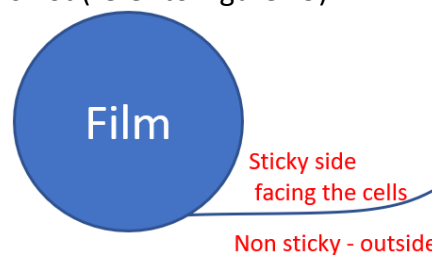

Figure 28: Typical film roll sides – General film roll for PV films



Figure 29: Bare cells colour and shape before the encapsulation. (project picture)

8.1.1. EVA

EVA, also known as poly (ethylene-vinyl acetate) (PEVA), is a sealant layer used to maximise protection of solar modules. The EVA comes in sheets and melts during the encapsulation process to create an adhesive. It is almost impossible to remove the EVA without damaging the cells after the encapsulation process has been actioned. Figure 31 shows the EVA sheet being applied to a sample module prior to encapsulation.



Figure 30: EVA sheet on the back of the solar cells- (project picture)

8.1.2. ETFE

ETFE is a strong, transmissible and flexible ultra-thin film. It can be used as a top cover of the solar cells. Figure 32 details ETFE film being applied to a sample module.



Figure 31: ETFE Infront of the cells (project picture)

8.1.3. PVDF

PVDF is a type of light fluoride material similar to plastic that can tolerate high temperatures. PVDF was provided by Tindo Solar. Figure 33 shows the PVDF being applied to one of the sample modules.



Figure 32: PVDF after the encapsulation (project picture)

8.1.4. Back sheet

The back sheet is the final layer of material in the PV module. This final layer provides protection, extra insulation from moisture and humidity and holds the shape for the entire module. An essential consideration when using PV back sheet is that one side is pre-coated

with EVA. This coated side must be positioned to face the solar cell within the covering material structure leaving the uncoated side to face the outer side. Figure 34 details back sheet positioning.

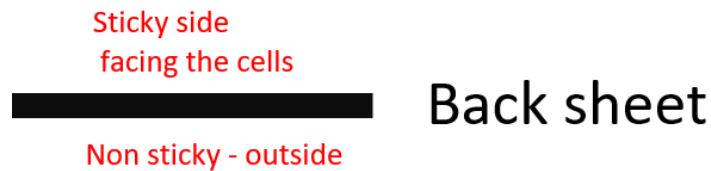

Figure 33: Back sheet sides showing the difference between the adhered side and not adhered side

8.1.5. Solar Cells

Three types of solar cells were used during production in this project. All sample modules were assembled and soldered at the University of Adelaide with assistance from Norio Itusmi.

These conditions are ideal for the commercial PV modules as they are needed to ensure the reliability and quality of the panel to last for 20 years. However, for solar car race and with the current structure of the film, these conditions can cause damage to the cells.

8.1.6. Tindo Karra 300 PERC

The Tindo Karra 300 PERC is a PV panel that comprises 60 solar cells in series connection (6 cells per row * 10 cells per columns). The solar cells are 4BB Mono-crystalline silicon which has an efficiency of 21.4%. The PV panel efficiency overall is 18%. This variation in efficiency is likely due to the different layers of protection used in the commercial panel. Table 5 summarises the technical specifications of the Tindo Karra 300 PERC panel.

Table 6: PV panel information

Single cell area	0.024336 m² (24336 mm² - 156x156mm)
PV panel area	1.667m²(1667 x 1000 x 40 mm)
Solar cells area	1.46016 m² (60 * 0.024336 m²)
PV panel weight	18.2 Kg

8.1.7. Sunpower C60 Cells

SunPower is a solar cell manufacturer that produce high-quality solar cells. SunPower C60 solar cells were used in production for some of the sample modules tested in this project. Although SunPower C60 is an older generation of solar cells they are generally considered

good value, have a similar shape to newer cells and are a relatively cheap option in the market. Figure 35 shows the mechanical dimensions (diagram) and electrical specifications (table6).

Table 7: Electrical specification of sunpower C60

Bin	Pmpp (Wp)	Eff. (%)	Vmpp (V)	Impp (A)	Voc (V)	Isc (A)
J	3.42	22.5	0.582	5.93	0.687	6.28

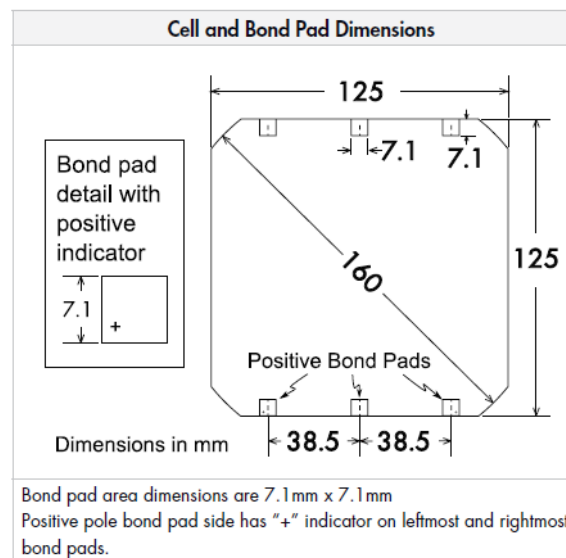

Figure 34 Specification SunPower cell C60 (SunPower C60 datasheet)

8.1.8. Sunpower MAXEON™ GEN III

The third generation of SunPower cells are called MAXEON GEN III and are more efficient than the second generation of SunPower cells. These cells were used in the project because the AUSRT team selected these cells for use in the solar racing vehicle, Lumin II MK II. These cells have approximately the same size and shape as the second generation. Figure 36 shows the mechanical dimensions (diagram) and electrical specifications (table 7).

Table 8: Electrical specification of MAXECON GEN III

Bin	Pmpp (Wp)	Eff. (%)	Vmpp (V)	Impp (A)	Voc (V)	Isc (A)
Le3	3.84	24.8	0.634	6.06	0.643	6.28

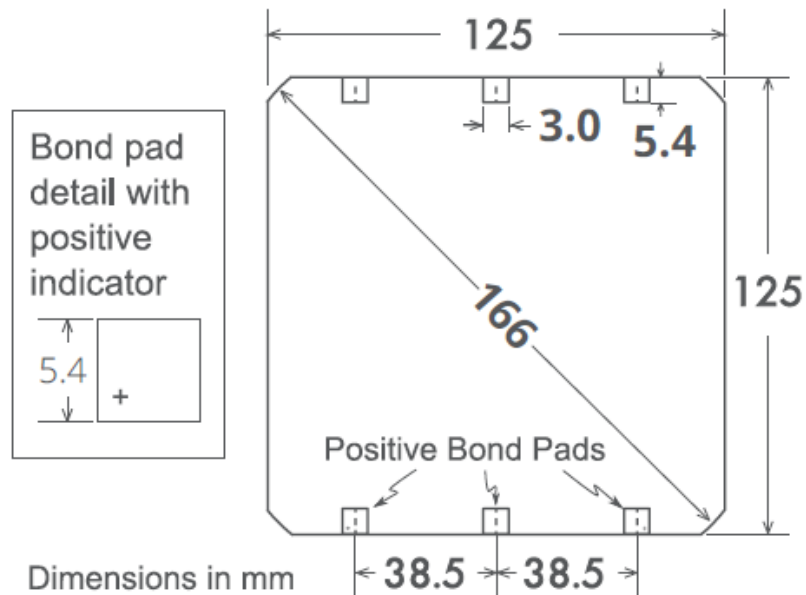

Bond pad area dimensions are 5.4mm x 3.0mm
 Metal finger pitch between positive and negative fingers is 471 μ m.
 Positive/Negative pole bond pad sides have "+/-" indicators on leftmost and rightmost bond pads

Figure 35: Specification SunPower cell MAXECON GEN III (SunPower MAXECON GEN III datasheet)

8.2. Outdoor Condition

The outdoor condition involved one trial. Figure 37 shows the two sample modules which consisted of 15 cells (3x5). The samples used PVDF and ETFE film respectively as indicated in Figure 37. Refer to Figures 15 and 16 for detail of the module structure, ie. ETFE/ Cell/ EVA/ Back sheet and PVDF/ Cell/ EVA/Back sheet.



Figure 36: (PVDF on the left - ETFE on the right)

Figure 38 shows the outdoor modules in the production line at the Tindo Solar facility. Specifically, this image is prior to lamination and the Teflon mesh used to prevent wrinkling is being placed on the modules.



Figure 37: (Teflon Sheet brown on the top of the arrays).

The modules were exposed to the commercial process parameters (98Kpa pressure) after the lamination process completed.

8.3. Indoor Condition

The indoor condition involved four trials. Each trial involved producing several samples.

8.3.1. Indoor Trial 1

The first indoor trial involved producing six single-cell samples. Cell number was reduced from 15 cells in the outdoor samples to the single cell to avoid wasting time and resources. The encapsulation process avoided piercing experienced in the outdoor trial by not using the Teflon mesh. This was suggested by Norio Itusmai, a University of Adelaide staff member. Itusmai also suggested reversing the layer of encapsulation to avoid the development of wrinkles in the absence of the Teflon mesh. This reversed structure is detailed in Figure 39. The single cell module was encapsulated without soldering electrical leads to the solar cells. Hence it was not possible for the electrical properties of the samples to be tested in this trial.

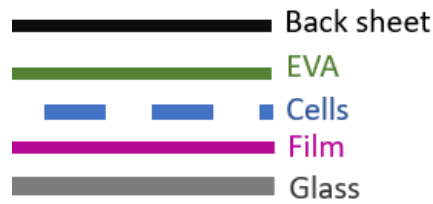

Figure 38: (Norio's method - the glass is not part of the module).

Tindo Solar provided a fine-textured glass plate that the modules were placed on in reverse method, ie. placed upside down, as detailed in Figure 40 and then positioned on the production line. These samples underwent the standard lamination process. Figures 41 through to 46 depict the trial one sample cells. After lamination, the sample modules in the first indoor trial were left for a few minutes to reduce to room temperature at which time it was observed that they were sticking to the glass plate. After investigating, it is suspected the glass surface was contaminated by EVA residue from previous trails. It is likely that the forced removal of the modules from the glass plate damaged the cells and impacted the data from this trial.

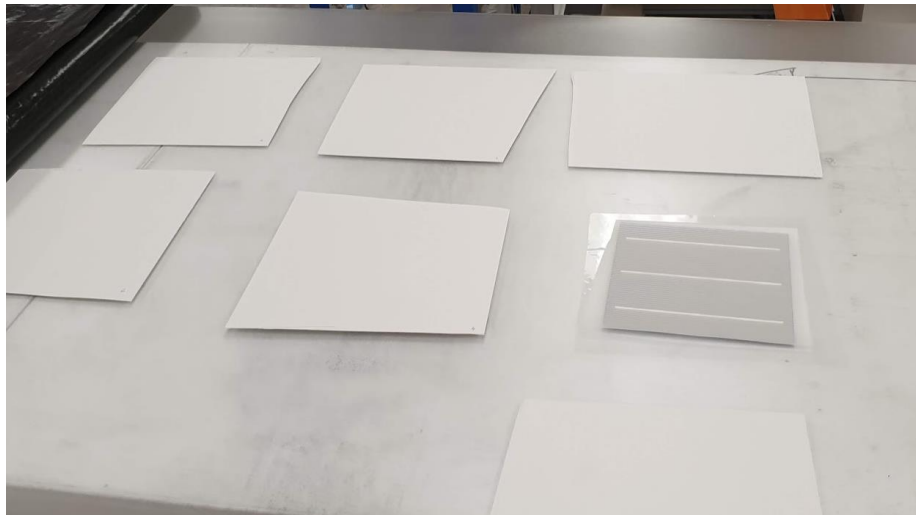

Figure 39: shows how the cells are placed in before the lamination – (project picture)

The sample structure are as follows:

- Single- celled (ETFE/Cell/ EVA/ETFE/Back sheet)
- Single- celled (ETFE/Cell/ EVA/Back sheet)
- Single- celled (PVDF/Cell/EVA/PVDF/Back sheet)
- Single- celled (PVDF/Cell/ EVA/Back sheet)
- Single- celled (PVDF/Cell/ EVA/ETFE/Back sheet)
- Single- celled (ETFE/Cell/ EVA/PVDF/Back sheet)



Figure 40: Module 1(ETFE/ Cell/ EVA/ Back sheet)



Figure 41: Module 2(ETFE/ Cell/ EVA/ ETFE/Back sheet)



Figure 42: Module 3(PVDF/ Cell/ EVA/ PVDF/Back sheet)



Figure 43: Module 4(PVDF / Cell/ EVA/ Back sheet)



Figure 44: Module 6(ETFE / Cell/ EVA/ PVDF/ Back sheet)



Figure 45: Module 6(PVDF / Cell/ EVA/ ETFE/ Back sheet)

After lamination, the sample modules in the first indoor trial were left for a few minutes to reduce to room temperature at which time it was observed that they were sticking to the glass plate. After investigating, it is suspected the glass surface was contaminated by EVA residue from previous trials. It is likely that the forced removal of the modules from the glass plate damaged the cells and impacted the data from this trial.

8.3.2. Indoor Trial 2

Some sample materials in trial one failed while others were more effective. The more effective material, specifically PVDF film, was used in trial two and the failed materials were

discarded. The size of the modules increased from a single cell to three cells in order to facilitate testing of the electrical performance of the module. Commercial modules typically include an MC4 PV connector which allows the module's energy to be accessed. In the sample modules, a makeshift electrical outlet was constructed using a bus-bar to function as this connector. The makeshift outlet in the sample modules was positioned in contact with the cell. The samples for trial two were constructed as follows:

- Three-celled structure (PVDF/EVA/CELL/ EVA/Back sheet) Outlet positioned on cell
- Three-celled structure (PVDF/ CELL/ EVA/ Back sheet) Outlet not positioned on cell
- Single-celled (ETFE/ CELL/ EVA/ Back sheet)
- Single-celled (ETFE/ CELL / EVA/ Back sheet) Flipped film

In addition to the three-cell sample modules, two single-celled samples were also made. The ETFE film has one adhesive inner side and one external non-adhesive side. During the production of the trial one samples; it was unclear if the ETFE adhered on the correct side. As a result, the single-cells samples in trial two were designed to act as a control to determine if the error in adhering the ETFE had impacted trial one results.

The three-celled samples for trial two involved the following steps. Firstly, crosses and coroners or spacers were 3D printed according to the solar cell dimensions (refer Figure 47). These spacers evenly separate the cells as well as minimise the over surface area of the cells. This is important to the visual impact of the module and maximises the use of space on the solar vehicle roof, where space is limited.



Figure 46: Solar cells spacers (project picture)

The samples in indoor trial two required significantly more man-handling than the previous samples. Safety gloves were worn to avoid traces of grease/sweat on the technicians' hands

from contaminating the cells. When soldering solar cells (refer figure 49) it was essential to maintain all cells in a precise straight line and caution was needed to avoid metal debris from causing damage to the module. Specifically, if metal debris lands between the top film and the cell there is a high chance of cell damage and piercing. Additionally, it was important at this stage to select the correct size of tabbing and ribbon and ensure correct use of Teflon tape to avoid short circuits. Figure # shows soldered cells and the use of spacers and figure 50 shows the trial two samples laid out on a glass plate ready to undergo the standard lamination process.

The approach to soldering used in this project is detailed as follows:

1. Ensure the cells cannot move by placing lightweight objects on the back of the cell
2. Wear gloves to avoid contamination through touching
3. Ensure neither side of eth cell is scratched
4. Solder quickly and efficiently as excess soldering can cause damage and insufficient damage can cause structural weakness
5. Ensure bus bars, tabs and wires are within the current limits
6. Ensure spacer was made in accordance with the manufacturer drawings
7. Clean tabs and busbars with an alcohol wipe to avoid contamination
8. Ensure soldering machine is at a sufficiently high temperature.

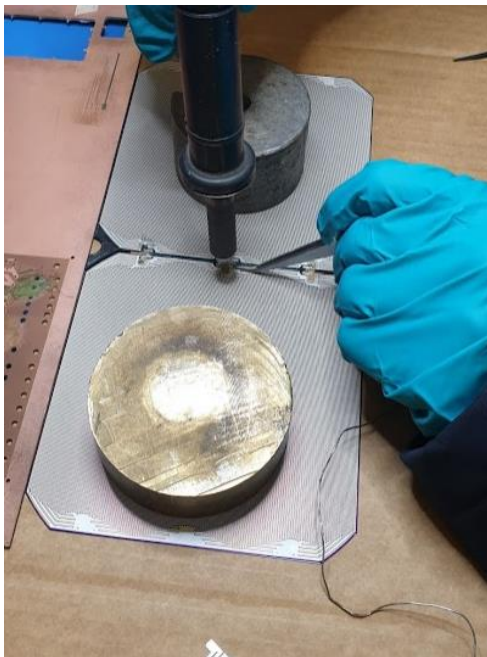

Figure 48: Soldering the cells (project picture)



Figure 47: The solar cells spaces whole soldering the cells (project picture)



Figure 49: Both modules prior to the lamination. (project picture)

8.3.3. Indoor Trial 3

Between indoor trial two and three, we received the AGC Chemical plasma treated films. Production of trial three sample modules drew on results from previous trials and incorporated the newly arrived films. It was suspected that the makeshift electrical outlets used in trial two samples caused damage to cells. For this reason, the PVDF sample module for trial three was duplicated with one module having an electrical outlet positioned on the cell and the second module not positioning the outlet on the cell. EL testing was used for the 3-celled modules in trial three. Six sample modules were constructed as follows:

- 3-celled structure (ETFE50/CELL/EVA/Back sheet) Outlet positioned on cell
- 3-celled structure (ETFE12.5/EVA/CELL/EVA/Back sheet) Outlet positioned on cell
- 3-celled structure (PVDF/CELL/EVA/Back sheet) Outlet positioned on cell
- 3-celled structure (PVDF/CELL/EVA/Back sheet) Outlet not positioned on cell
- Single-celled (ETFE25/ CELL/EVA/Back sheet)
- Single-celled (ETFE12.5/CELL/EVA/ Back sheet)



Figure 50: Cutting the films to the modules size (project picture)

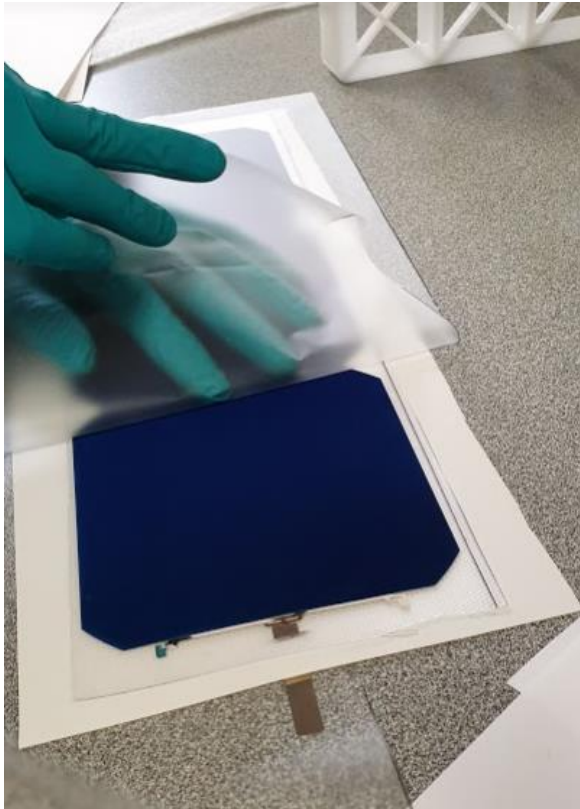

Figure 51: After constructing the modules (project picture)



Figure 52: Preparing the modules for the EL testing (project picture)

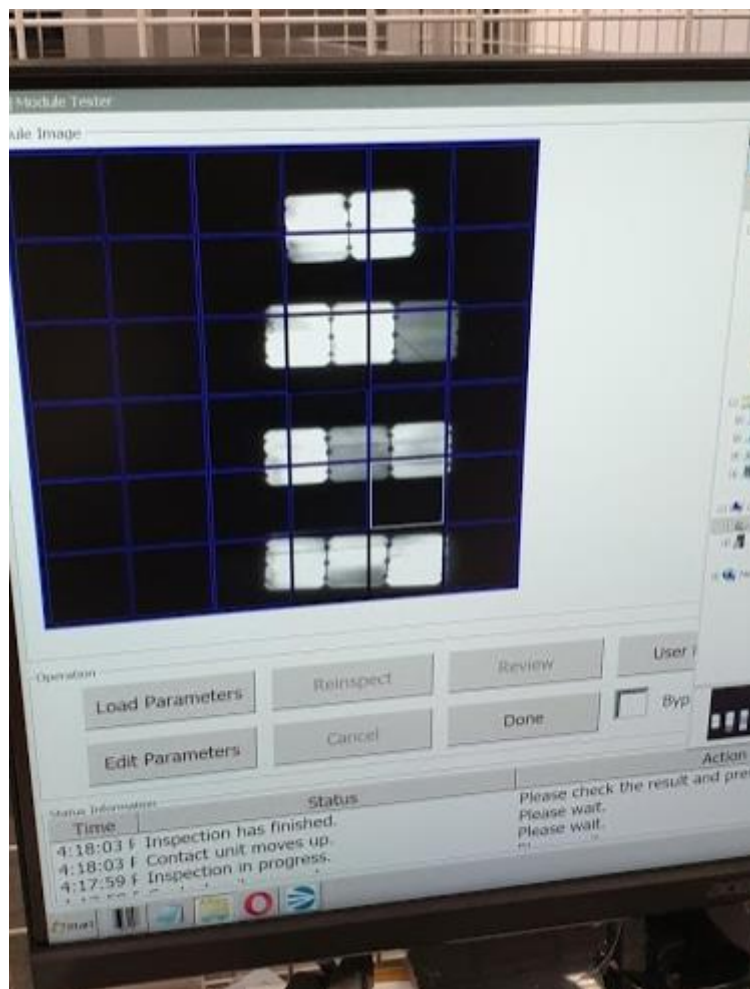

Figure 53: EL testing scan on the computer (project picture)

8.3.4. Indoor Trial 4

Trial three results were inconclusive. This was due to damage to cells revealed by EL testing which will be discussed further in the results. Trial four involved reproducing two of the same samples as in trial three, marked below with an asterisk. The single-celled samples were not

replicated in trial four. Two new sample modules were constructed using ETFE12.5 without a top EVA layer and an ETFE25 sample was also produced. All modules in this trial were constructed with the electrical outlets positioned on the cell. Trial four samples involved non-standard lamination parameters for pressure reducing the KPa from 98 to 50 as detailed in Table #. This was suggested by AGC Chemical who drew attention to specifications for the plasma-treated ETFE films which suggested different parameters for lamination. The four sample modules used in trial four are as follows:

- 3-celled structure (ETFE50/CELL/EVA/Back sheet)*
- 3-celled structure (PVDF/CELL/EVA/Back sheet)*
- 3-celled structure (ETFE12.5/CELL/EVA/Back sheet)
- 3-celled structure (ETFE25/CELL/EVA/Back sheet)

Table 9: Difference between the lamination parameters.

Parametres	Standard Parameters	Adjusted Parameters
Temperature	142 degrees C	142 degrees C
Pressure	98KPa	50KPa
Suction	Utilised	Utilised

8.3.5. Indoor Trial 5

The fifth and final indoor trial involved the production of three sample modules. The ETFE12.5 sample from trial four failed and was thus not repeated. The other three sample modules from trial four were replicated with an additional top layer of EVA. All modules in this trial were constructed with the electrical outlets positioned on the cell. The three sample modules used for trial five were as follows:

- 3-celled structure (ETFE50/EVA/CELL/EVA/Back sheet)
- 3-celled structure (PVDF/EVA/CELL/EVA/Back sheet)
- 3-celled structure (ETFE25/EVA/CELL/EVA/Back sheet)

Trial five samples utilised the non-standard lamination parameters detailed in Table #.

8.4. Outdoor Results

Both outdoor sample modules were tested in the Spi-Sun Simulator TM 4600SLP twice to compare the consistency of results.

Table 10: Simulation results for both modules

Simulator Parameters	PVDF Simulation 1	PVDF Simulation 2	ETFE Simulation 1	ETFE Simulation 2
Irradiance	100.015	100.021	99.9649	99.9988
rrCorr	100	100	100	100
Lamp Voltage	2000	2000	2000	2000
Corrected To	100	100	100	100
Module Temp	23.6738	23.54	24.0843	23.9692
Corrected To	25	25	25	25
RCCC	0.8346	0.8346	0.8346	0.8346
Voc	10.1049	10.0925	10.1276	10.1221
Isc	8.45286	8.45936	8.83983	8.84315
Rseries	0.11664	0.10281	0.12301	0.12904
Rshunt	34.698	37.2323	47.4729	39.5369
Pmax	66.9293	66.9575	69.0963	69.2468
Vpm	8.3759	8.37906	8.45092	8.37809
Ipm	7.9907	7.99104	8.17619	8.26522

Results of this simulation testing indicated that testing was conducted consistently. Results indicate that exposing the ETFE module to maximum light spectrum produced 69.246W compared to the PVDF module which produced 66.57W. Data showed that the sample modules failed to produce 75W as would typically be expected of a 15-cell module. Notably, holes were observed in the top sheet and it is suspected that this piercing caused damage throughout the module impacting these results.

8.5. Indoor Results

8.5.1. Indoor Results Trial 1

Six samples were tested in trial one using Hydro Testing and assessing the quality of lamination. At this stage the purpose of testing was to assess the bonding properties of the lamination method and the structure of the covering materials. The table below summarises the results.

Table 11: Results of trail 1

Module	Adhered	Notes	Hydro Test
ETFE/Cell/ EVA/ETFE/Back sheet	No	adhered to the glass/ Back sheet peeled off	N/A
ETFE/Cell/ EVA/Back sheet	No	adhered to the glass	N/A
PVDF/Cell/EVA/PVDF/Back sheet	Yes	adhered to the glass/ Back sheet peeled off	Passed
PVDF/Cell/ EVA/Back sheet	Yes	adhered to the glass	Passed
PVDF/Cell/ EVA/ETFE/Back sheet	No	adhered to the glass adhered to the glass	N/A
ETFE/Cell/ EVA/PVDF/Back sheet	Yes	adhered to the glass/ Back sheet peeled off	Passed

Results indicate that all sample modules adhered to the lamination glass which is not desirable. When modules adhere to glass after lamination it will be unlikely that the modules can be removed without causing damage to the cells. This trial revealed the significance of ensuring precision in EVA, back sheet and top film application. These results confirm that the positioning of layers in the module must be precise as indicated in figure 55.

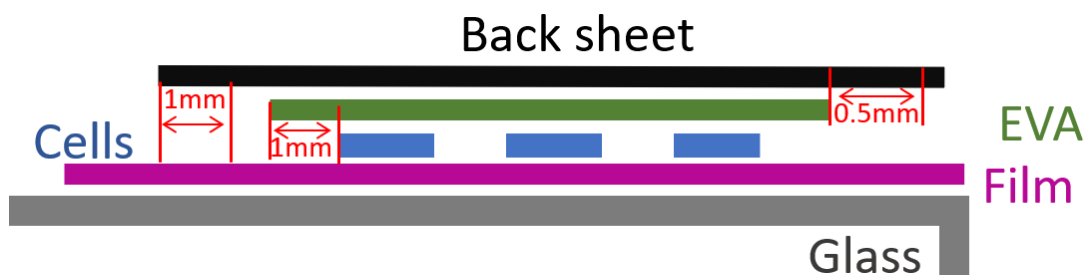

Figure 54: Spaces should be considered when performing lamination

As per Table # those sample modules that failed to adhere sufficiently were not applicable for Hydro Testing. Those samples that did adhere sufficiently were observed to have holes in them but once the holes were patched the modules passed the Hydro Testing without any leakage from the corners. This indicated that they had been successfully laminated. Figure 56 shows a patched module undergoing Hydro Testing.

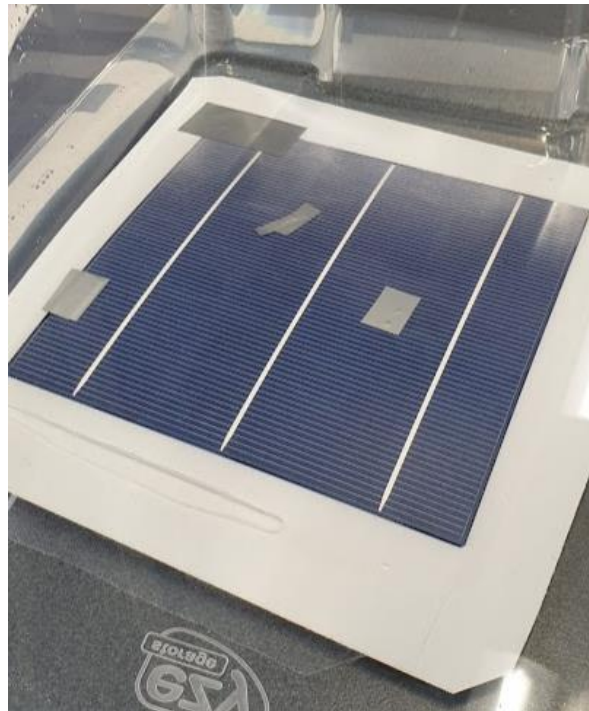

Figure 55: Sample going through hydro testing - (project picture)

The holes observed in the sample modules were inspected under a microscope which revealed that; some holes were due to cracks in the cells, some holes formed during the lamination process and some holes were formed as a result of contaminants between the cells and the film. Figures 57-60 illustrate the damage to these cells.

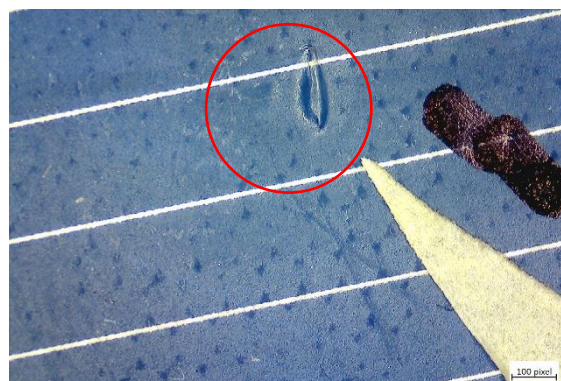

Figure 56: Microscope image showing a hole (project picture)

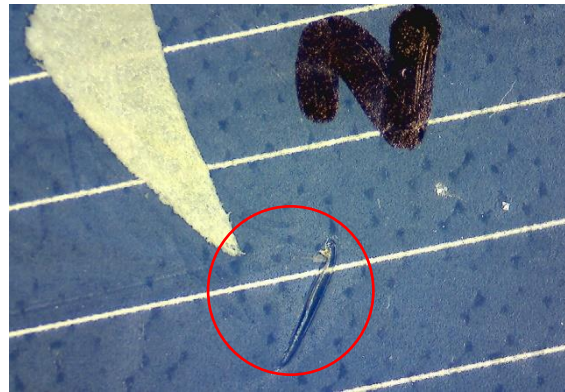

Figure 57: Microscope image showing a hole (project picture)



Figure 59: Microscope image showing a crack- (project picture)

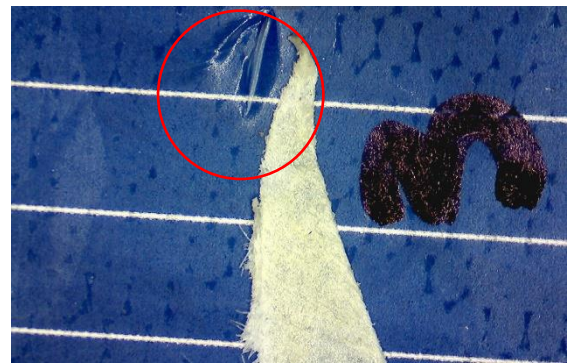

Figure 58: Microscope image showing a hole (project picture)

8.5.2. Indoor Results Trial 2

The single-celled samples in this trial were used to assess the effectiveness of the adhesive film. The adhesive failed drastically, and the non-plasma treated ETFE film was not used again in the production of samples. Trial two utilised EL testing and MPPT testing for the two three-celled sample modules. A third sample module was constructed at this point to assess the maximum power output from a three-cell module without any coverings. This third module was used as a control.

The makeshift electrical outlets constructed into the three-celled sample modules in this trial were positioned on the cell. Damage to the cell was observed around the outlet area suggesting that the position of the bus-bar in combination with the pressure during lamination had caused damage to the cell.

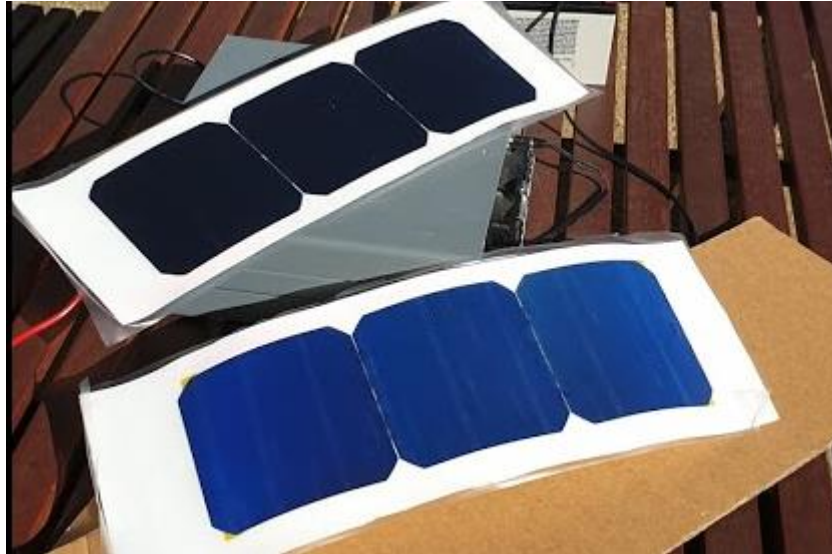

Figure 60: Three-celled sample module

Figure 61 shows the two three-celled sample modules during MPPT testing while Figure 62 shows the bare three-cell module. Notably, wrinkles can be observed in the bottom module in Figure 61 but these wrinkles are not deemed large enough to be of concern for a module this size.

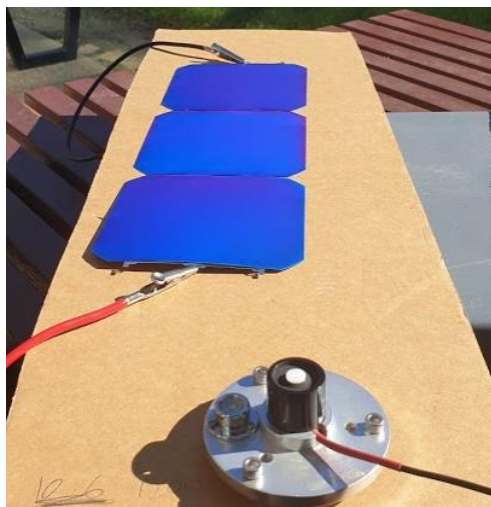

Figure 61: Bare cells and the irradiation sensor. - (project picture)

Table 12 Results MPPT testing the same irradiation (1000 W/m²)

Sample Module	Maximum Power Output
Bare cells	9.53W
PVDF/ CELL/EVA/Back sheet (one-sided)	9.09W
PVDF/EVA/CELL/EVA/Back sheet (two-sided)	6.9W

Table 9 indicates that the PVDF module with only the bottom layer of EVA produced 30% more output than bare cells or the PDVF module two layers of EVA. These results were shared with Tindo Solar who requested to conduct indoor tests on the modules to confirm the results. Tindo Solar performed EL testing (as the modules were too small for simulation testing). The results of Tindo Solar tests indicated only 8% more output for the one-sided PDVF sample.

El testing results are illustrated in Figure 63 which show considerable damage to the cells. The table in Figure 63 details the electrical properties of the three-celled sample modules. After sharing the EL Testing results with Tindo Solar, Tindo advised that there is no way to determine the cause of damage. Possible causes could include:

- The outlet soldering tabs were too thick
- Excessive pressure during the lamination
- Contamination between the cells and the film
- Mishandling while removing the cells or while transporting the cell from and to Tindo

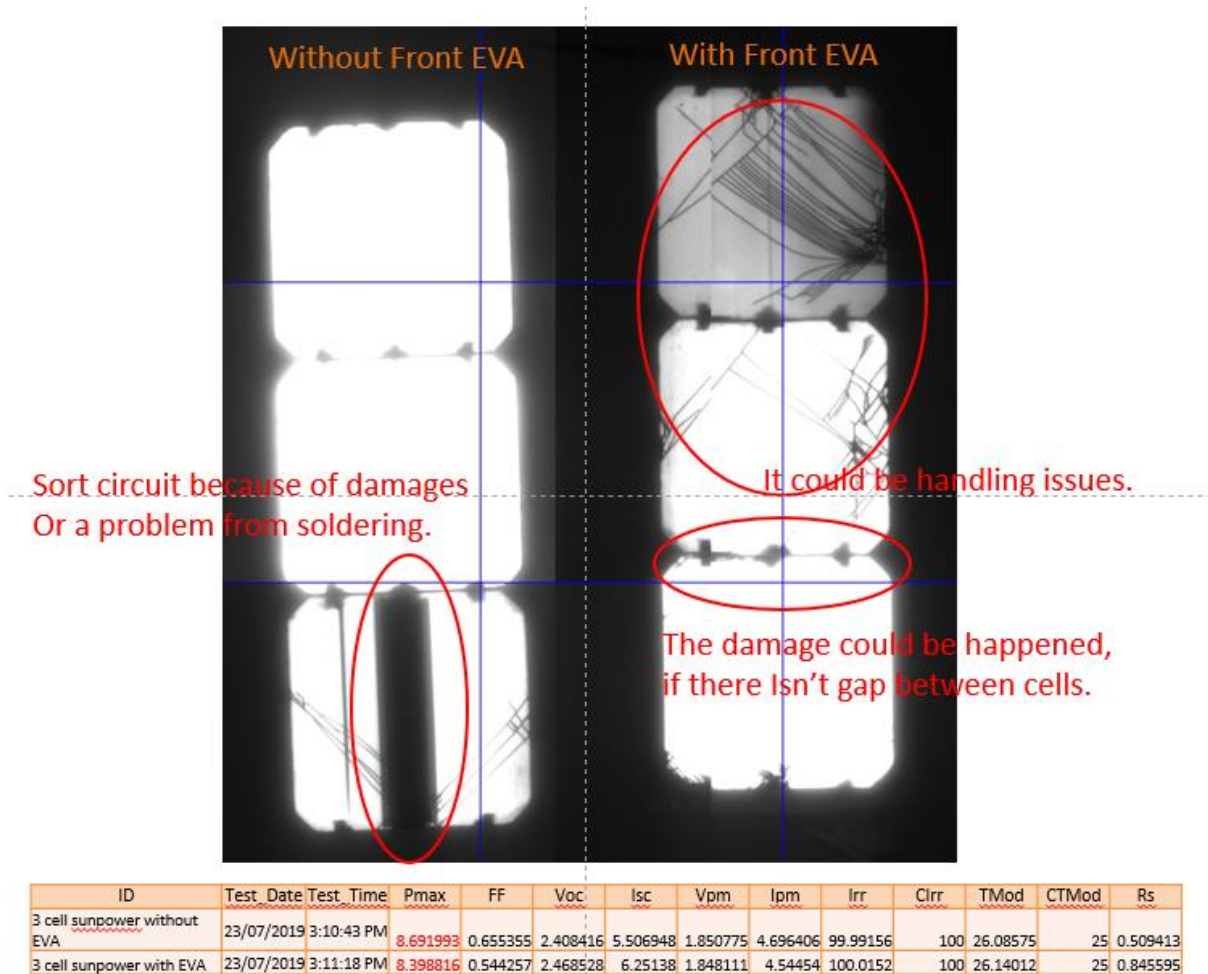

Figure 62: EL testing for both modules - (project picture)

8.5.3. Indoor Results Trial 3

As in trial two, the single-celled samples which used ETFE12.5 and ETFE25 respectively were tested to assess the effectiveness of the bonding properties. The layers in these single-celled samples successfully and thus progressed to the next trial which involved electrical testing. Trial number three also involved EL testing and MPPT testing of four three-celled sample modules. Table 12 shows the results of MPPT testing indicating the power output of each sampling module. Figure 64 and Figure 65 show the results of EL testing which indicate a short circuit in. It can clearly note the short circuit in the first sample and the crack in the second sample. Remarkably, wrinkles can be observed in the on the ETFE12.5 module as figure 66 illustrate.

The position of the makeshift electrical outlets constructed into the three-celled sample modules in this trial were varied to determine how the positioning of the bus-bar may have

caused damage to cells in trial two. Unfortunately, EL testing revealed that the cells in question were already damaged, hence the trial relating to the bus-bar damage was inclusive.

Table 13: Trial 3 MPPT Testing results and notes

Sample Module	Power (W) – Measure 1	Power (W) – Measure 2	Note
PVDF/CELL/EVA/Back sheet	2.25	2.28	Short Circuit
PVDF/CELL/EVA/Back sheet	6.88	6.85	Cracked
ETFE12.5/CELL/EVA/Back sheet	6.46	6.42	Wrinkles
ETFE50/CELL/EVA/Back sheet	8.89	8.86	-

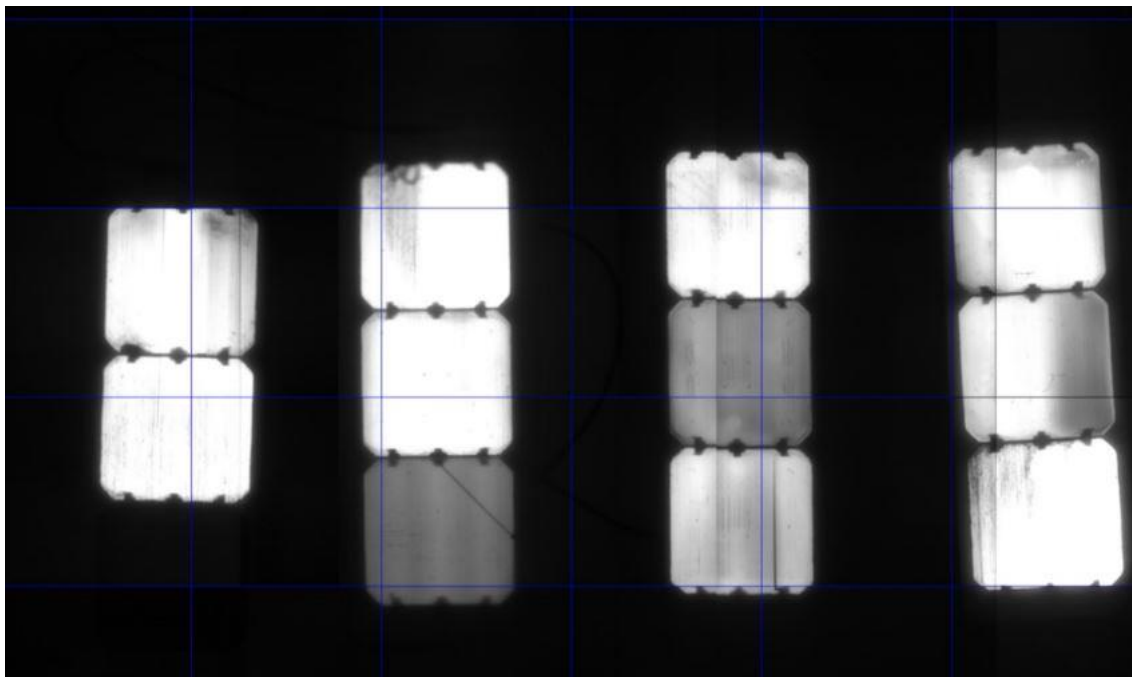

Figure 63: After lamination (left to right) PVDF, PVDF, ETFE12.5 and ETFE50- (project picture)

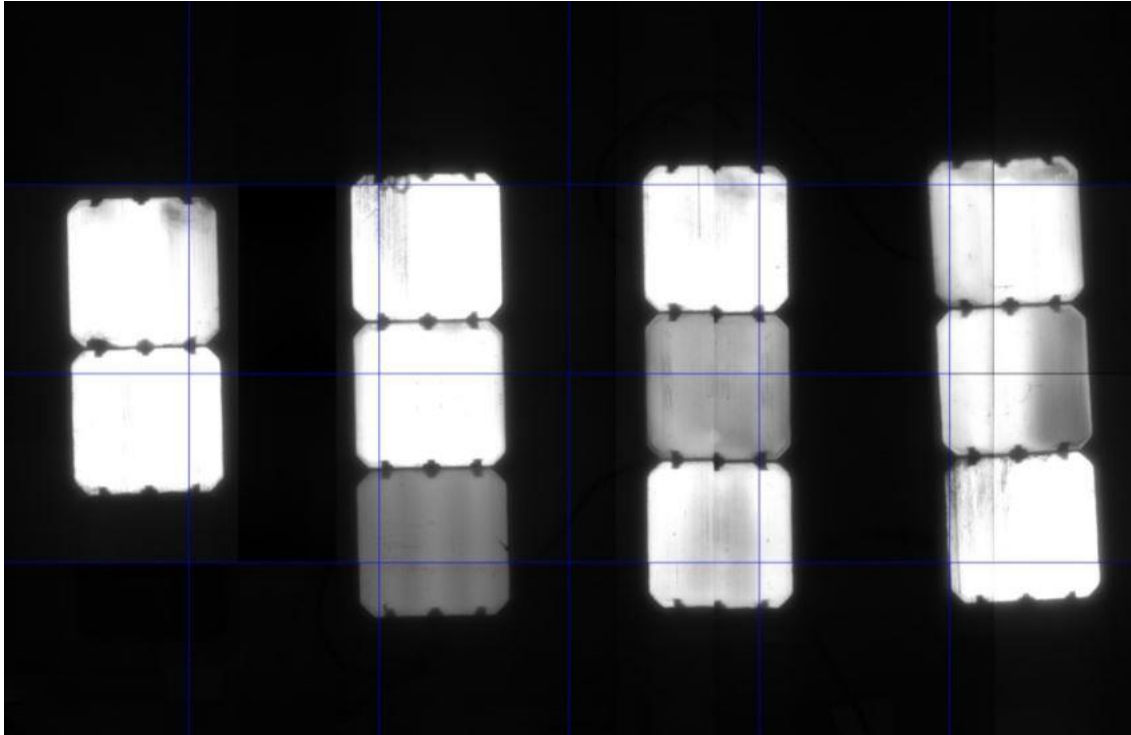

Figure 64: Before lamination (left to right) PVDF , PVDF , ETFE12.5 and ETFE50 - (project picture)

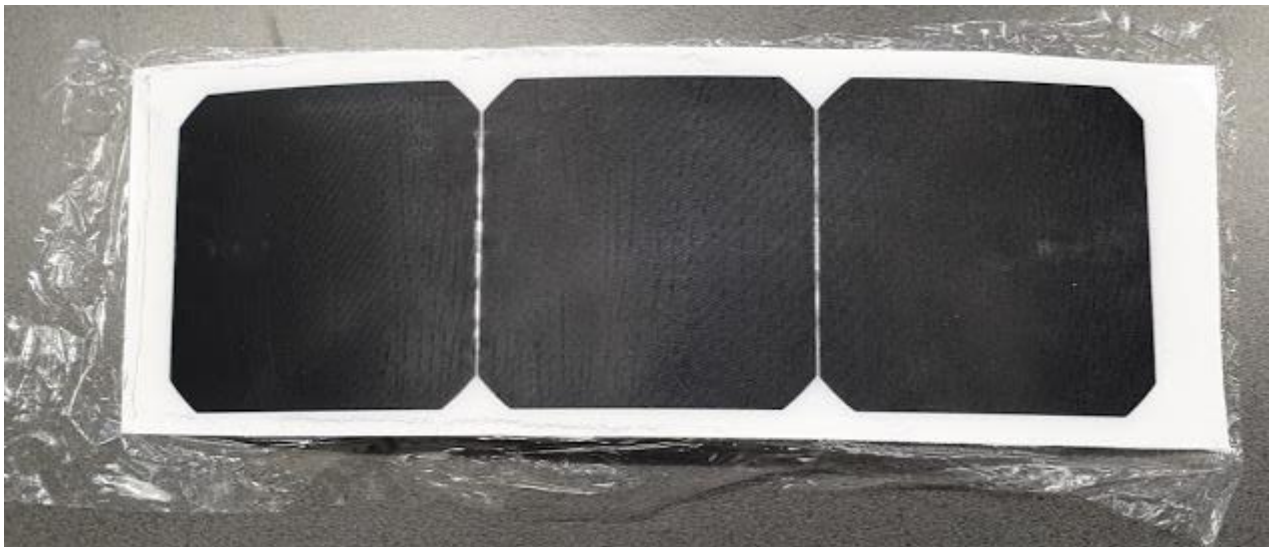

Figure 65: ETFE12.5 film encapsulated and showing wrinkles - (project picture)

8.5.4. Indoor Results Trial 4

Trial four involved MPPT testing and EL testing to assess four modules. Table # indicates the results of the MPPT Testing which indicates that the ETFE50 achieved a higher maximum power compared to the other sample modules. ETFE12.5 failed to adhere and was therefore not tested. Modules underwent EL testing as illustrated in Figure 68 (before) and Figure 67 (after) from left to right ETFE50, PVDF, ETFE12.5 and ETFE25. Results show that the ETFE12.5 module failed as expected. This trial was considered a success because the sample module

components adhered successfully without observable damage to cells (with the exception of the ETFE12.5) This success is highly likely to be the result of the non-standard lamination parameters for pressure. By trial four the positioning of the makeshift electrical outlet on the sample modules was not causing any damage to the cell. This may be due to the reduced pressure utilised during the lamination process.

Table 14: MPPT Testing results

Sample Module	Power (W) – Measure 1	Power (W) – Measure 2
ETFE50/CELL/EVA/Back sheet	9.03	8.96
PVDF/CELL/EVA/Back sheet	8.79	8.78
ETFE12.5/CELL/EVA/Back sheet	Not tested – failed to adhere	
ETFE25/CELL/EVA/Back sheet	8.85	8.8

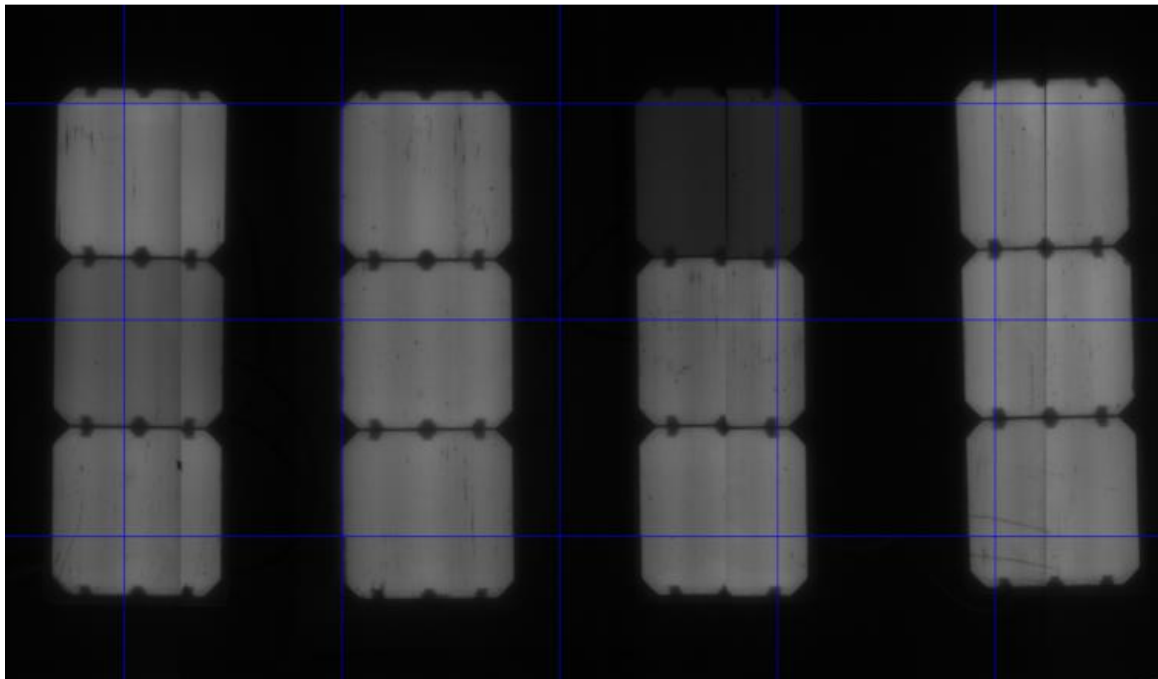

Figure 66: EL Testing after lamination from left to right (ETFE50, PVDF, ETFE12.5, ETFE25) - (project picture)

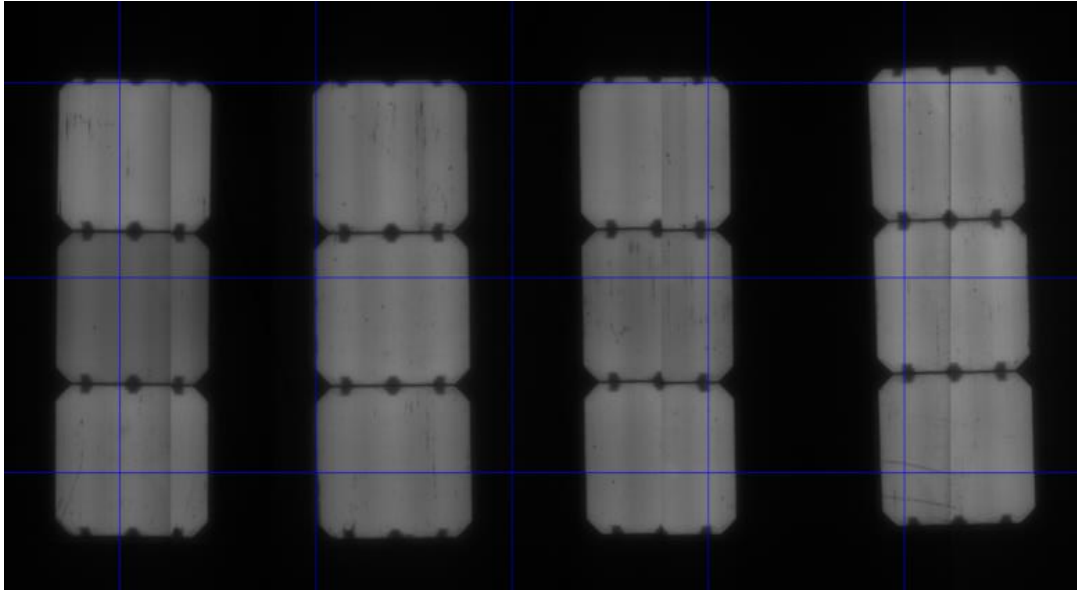

Figure 67: EL Testing before lamination from left to Right (ETFE50, PVDF, ETFE12.5, ETFE25) - (project picture)

8.5.5. Indoor Results Trial 5

MPPT testing was used to test three modules in trial five to compare the difference between having a bottom and top layer of EVA (two-sided) as opposed to just a bottom layer (one-sided). The results across the three sample modules were consistent as the two-sided structure reduces the overall performance of the module by between 8 and 11%. Like in trial four, the positive results in trial five are likely due to the use of non-standard lamination parameters for pressure.

Table 15: Table showing the MPPT testing

Sample Module	EVA one-sided Measure 1	EVA one-sided Measure 2	EVA two-sided Measure 1	EVA two-sided Measure 2
ETFE50/EVA/CELL/EVA/Back sheet	8.89	8.94	7.89	7.86
PVDF/EVA/CELL/EVA/Back sheet	8.79	8.77	7.77	7.76
ETFE25/EVA/CELL/EVA/Back sheet	8.82	8.83	7.71	7.68

8.5.6. Summary

The results indicate that the following materials are not suitable for the purpose of this project. ETFE without plasma treatment was not suitable for solar cell encapsulation using standard lamination parameters. Furthermore, ETFE12.5 with plasma treatment was also found to be unsuitable. Results show that the two-sided EVA reduced power out of the modules across all sample modules with power reduction estimated to be between 8 and 11%. Finally, ETFE50 was found to be the most suitable material for solar cells in solar racing vehicles.

9. Bridgestone World Solar Challenge Results

The Adelaide University Solar Racing Team (AUSRT) utilised the solar cells developed in this project in their solar racing vehicle Lumin II MK II which competed and completed the BWSC 2019 event. The performance of the project solar cells was observed throughout the 6-day challenge. Observations are as follows.



Figure 68: AUSRT at the finish line after completing the race

9.1. Day One

Location commenced: Darwin

Location completed: Warloch parking bay

Distance travelled today: 457KM

Distance travelled to date: 457KM

Day notes: The solar vehicle experienced three major problems on day one.

1. The wheel cover of the dive wheel flu off which generated significant drag on the car causing the car to consume an excessive amount of energy. This is apparent in the race data in figure 70 before 12:04
2. The driver switched off the car at Kathrine Control Stop which meant the solar cells were not charging to the battery. This is apparent in the race data in Figure 70 and 71 between 13:51 – the driver switched off the car and stopped recording.
3. The terrain for the first 300Km was hilly and steep which consumed a substantial amount of energy. This is apparent in the race data in Figure 70 .

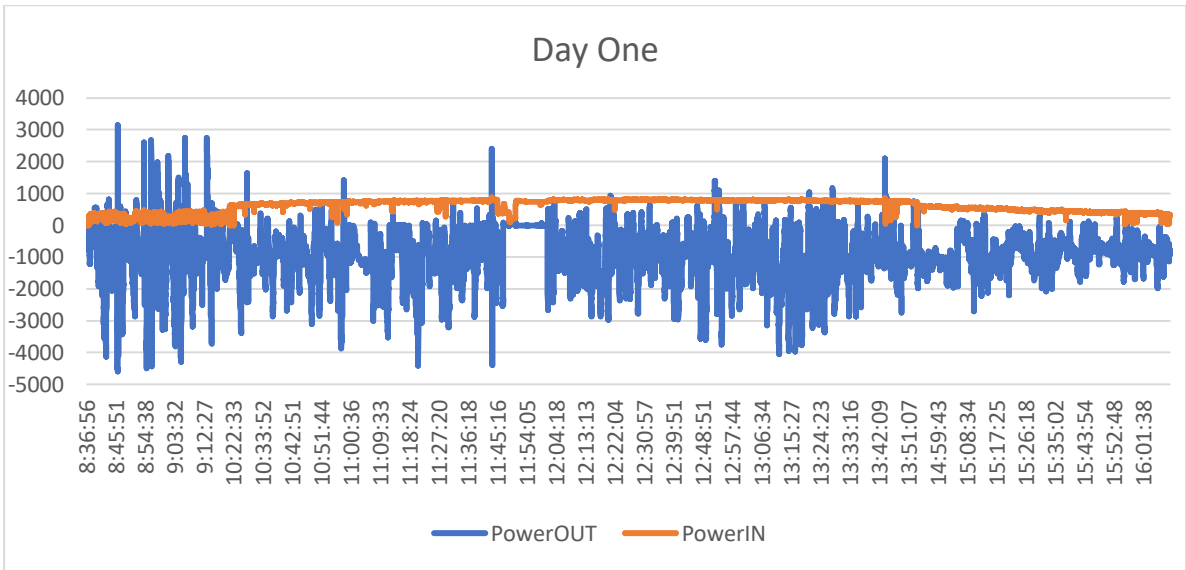

Figure 69: Day one power in and out Vs the time

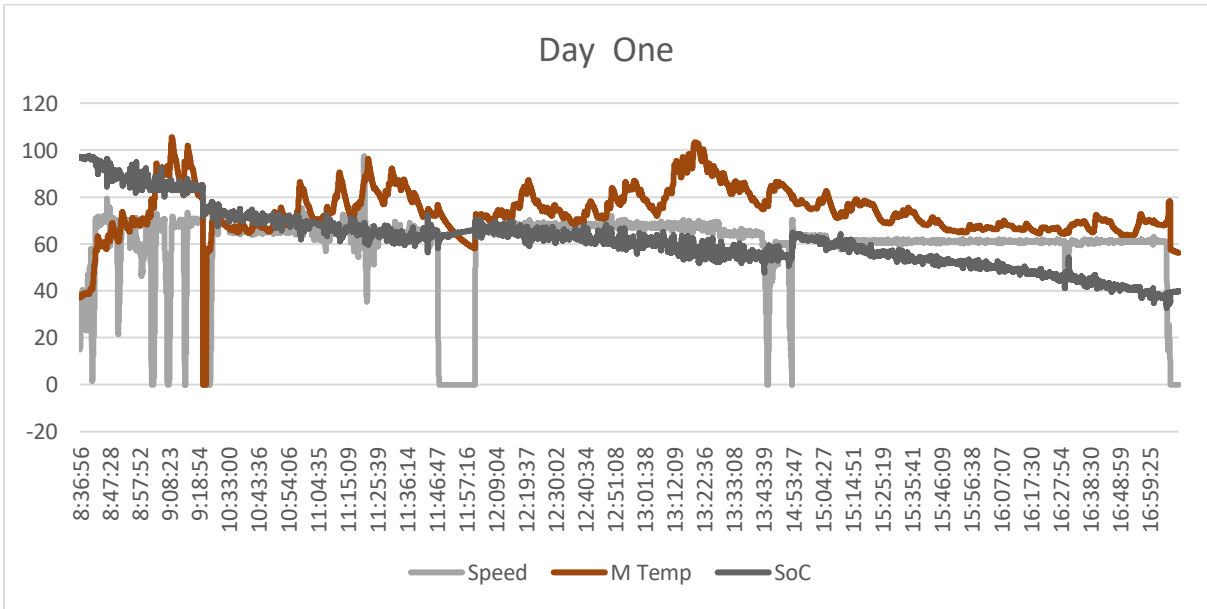

Figure 70: Day one SOC, Speed and motor temperature Vs the time

9.2. Day Two

Location commenced: Warloch parking bay

Location completed: Renner Spring

Distance travelled today: 368KM

Distance travelled to date: 825KM

Day notes: The vehicle broke down at Daly Water Control Stop when the steering wheel broke and the drive wheel wishbone broke simultaneously. This took three hours to replace which can be observed in Figure 72 during (13:27).

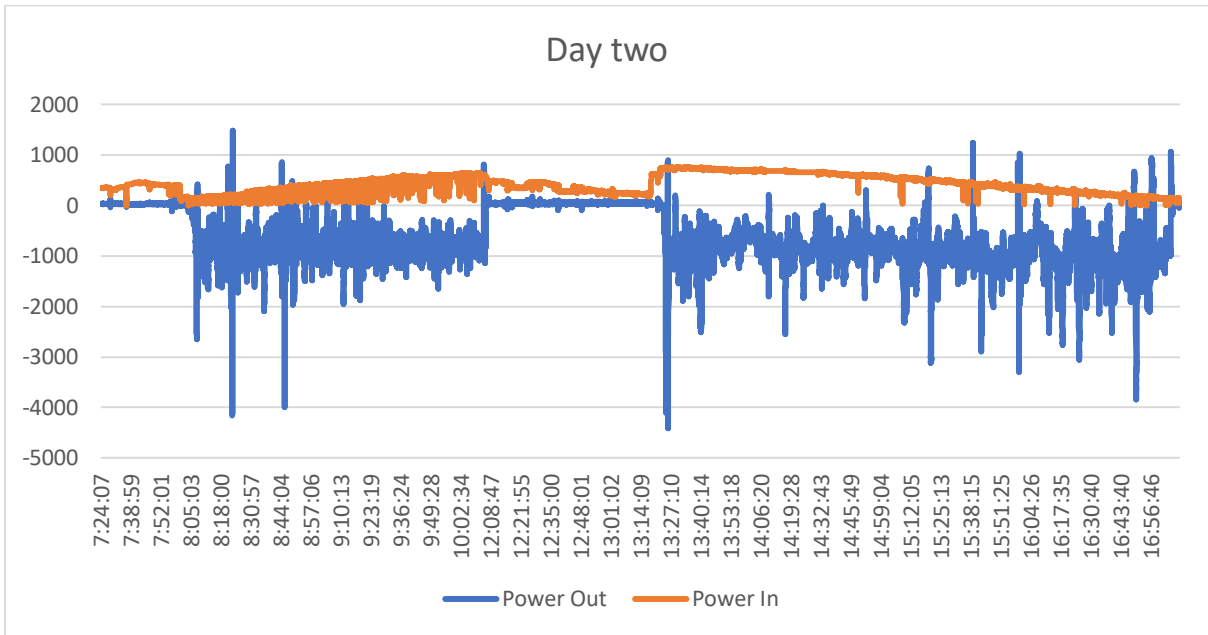

Figure 71: Day two power in and out Vs the time

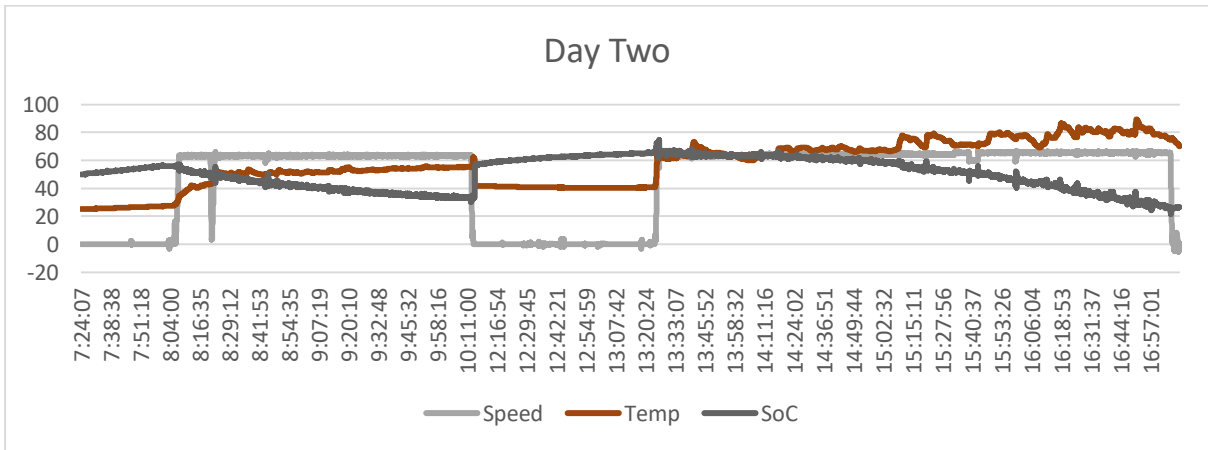

Figure 72: Day two SOC, Speed and motor temperature Vs the time

9.3. Day Three

Location commenced: Renner Spring

Location completed: Stuart Memorial

Distance travelled today: 454KM

Distance travelled to date: 1279KM

Day notes: Cloudy weather in the afternoon which impacted power output as evident in Figure 74 after 14:49

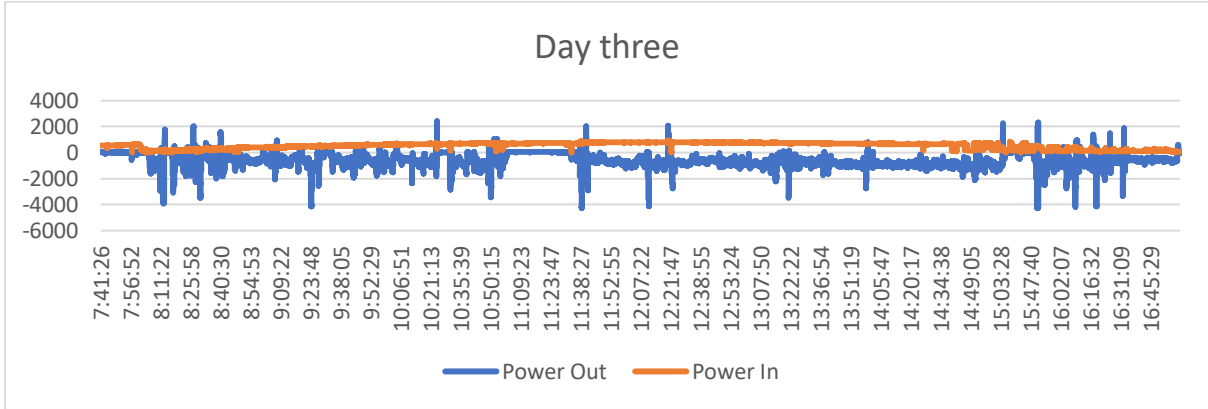

Figure 73: Day three power in and out Vs the time

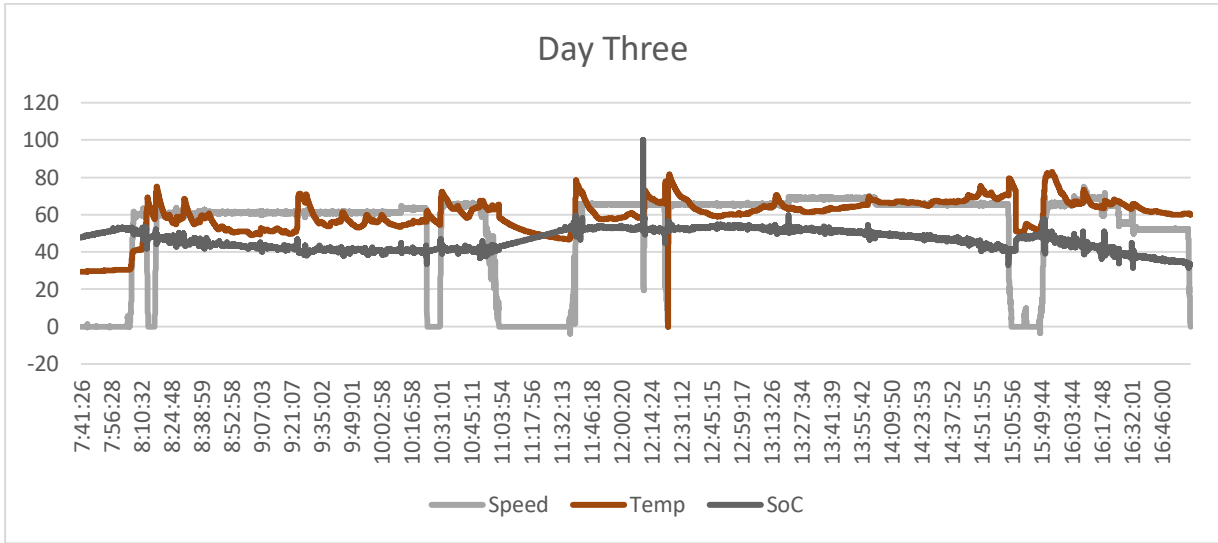

Figure 74: Day three SOC, Speed and motor temperature Vs the time

9.4. Day Four

Location commenced: Stuart Memorial

Location completed: Kulgera Control Stop

Distance travelled today: 486KM

Distance travelled to date: 1765KM

Day notes: Very cloudy morning led to a depleted battery by the end of the day which can be observed in both Figure 76 and Figure 77.

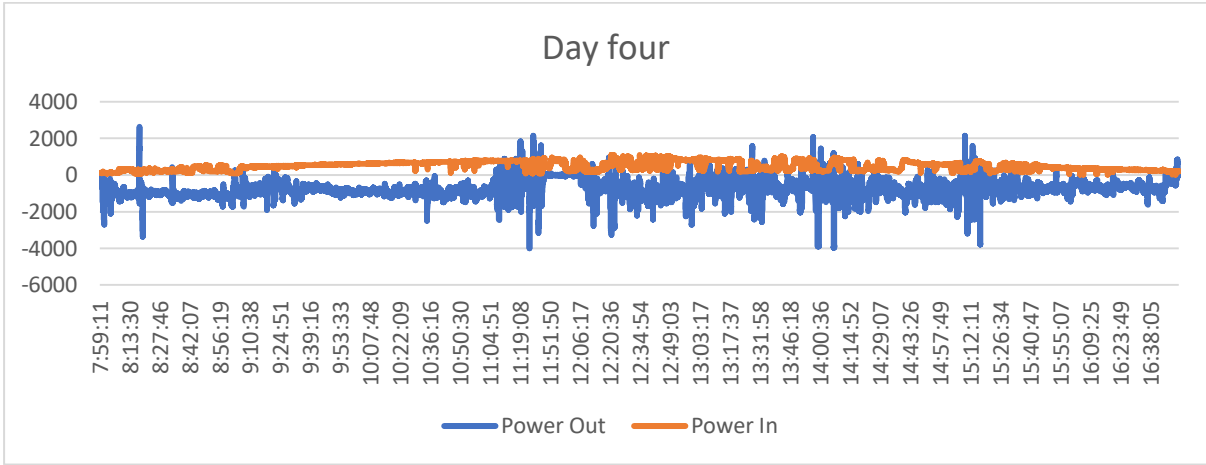

Figure 75: Day four power in and out Vs the time

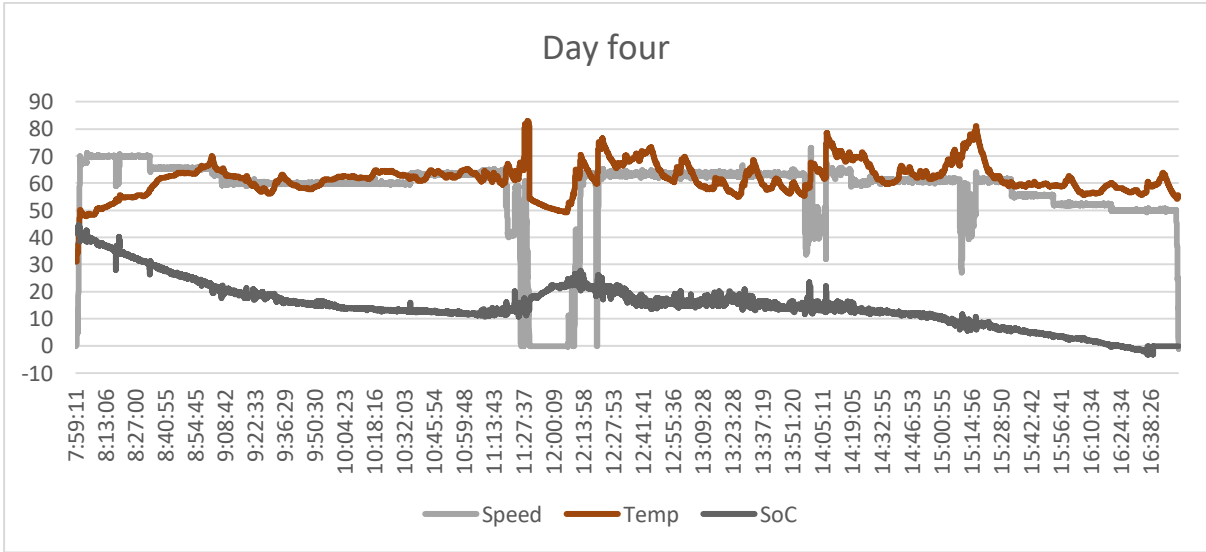

Figure 76: Day four SOC, Speed and motor temperature Vs the time

9.5. Day Five

Location commenced: Kulgera Control Stop

Location completed: Ingomare Mount Sandy

Distance travelled today: 458KM

Distance travelled to date: 2261KM

Day notes: Between completion of racing on Day Four and commencement of racing on day Five the solar cells were able to charge the battery to 36%.

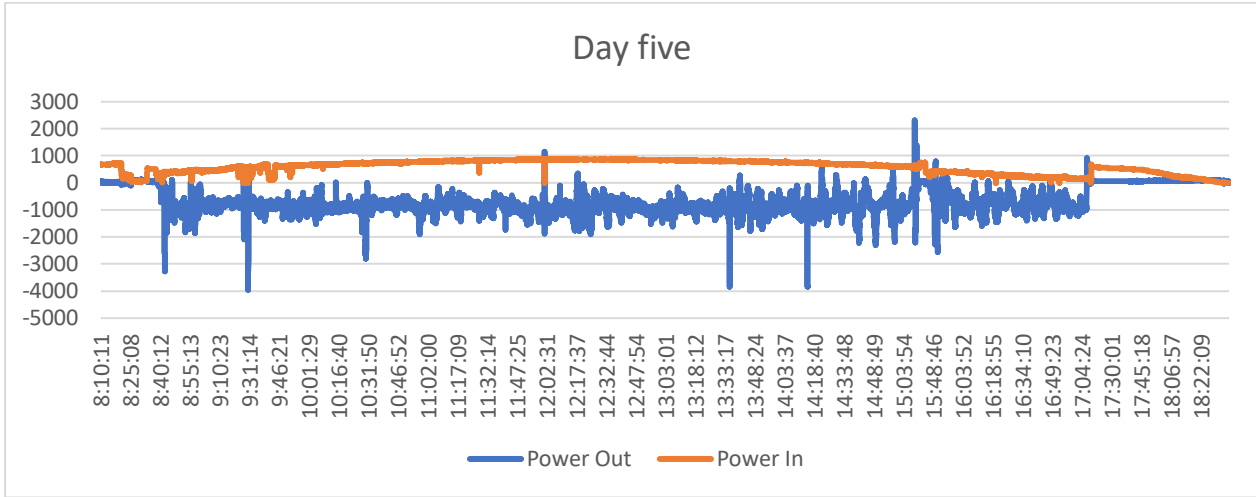

Figure 77: Day Five power in and out Vs the time

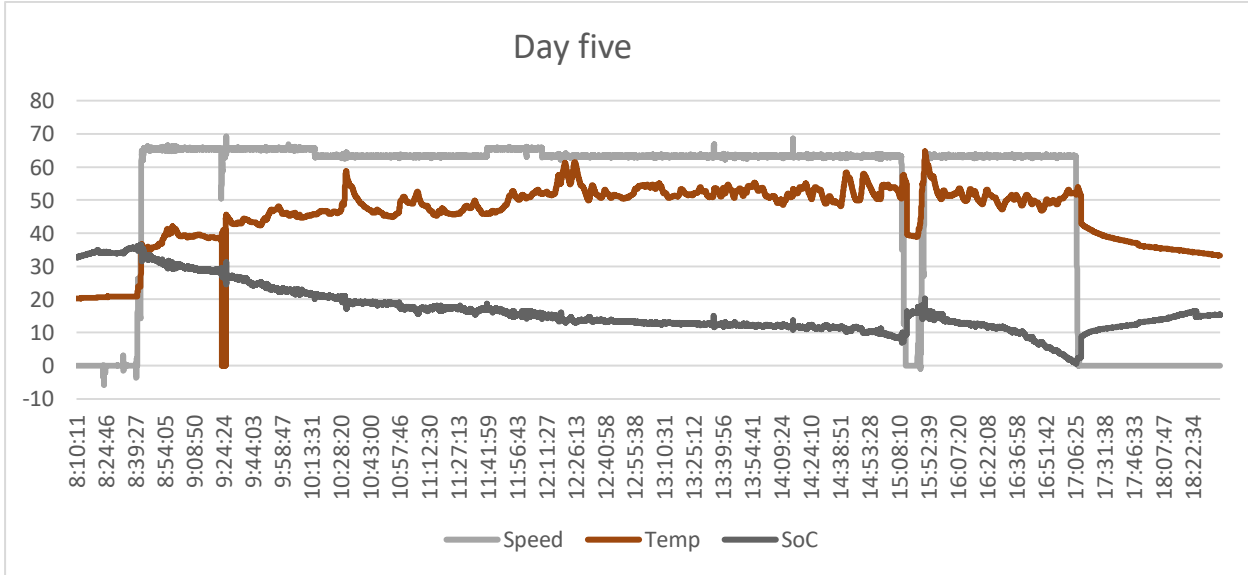

Figure 78: Day five SOC, Speed and motor temperature Vs the time

9.6. Day Six

Location commenced: Ingomare Mount Sandy

Location completed: Port Augusta (race completion)

Distance travelled today: 458KM

Distance travelled to date: 2719KM

Day notes: Race was successfully completed by Lumin II MK II for the first time. Vehicle was towed to Adelaide using a trailer.

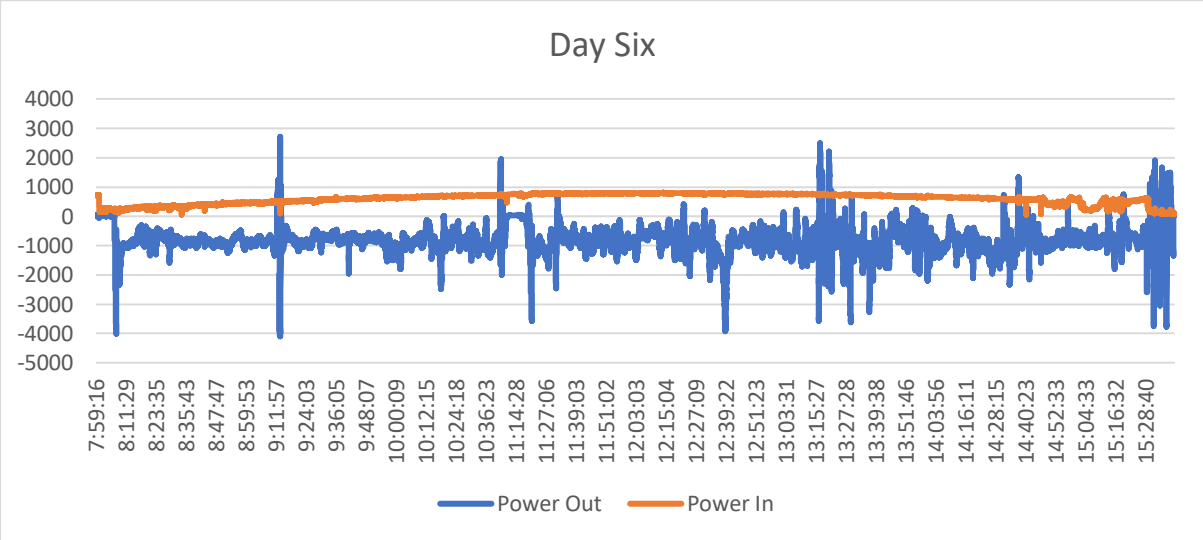

Figure 79: Day six power in and out Vs the time

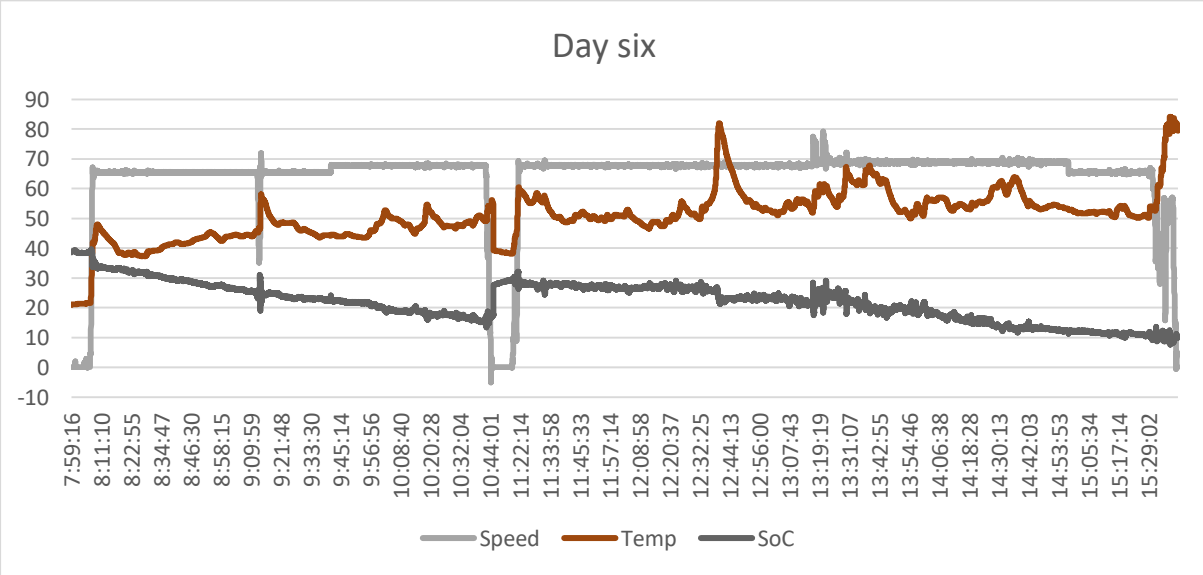

Figure 80: Day one SOC, Speed and motor temperature Vs the time

10. Conclusion

Solar cells are a sensitive material that requires a complex covering material for protection and structure. The covering materials used in solar cells are critical to solar modules' performance and durability. Solar technology companies typically prioritise durability of cells throughout the manufacturing process because this serves a broad range of commercial interests and consumer needs. However, the focus on durability compromises short term energy performance. In a solar vehicle race, maximum output and immediate energy utilisation is a higher priority than durability. This project sought to explore how the manufacturing process and materials could be adjusted in order to maximise the short-term output for cells used in a solar racing vehicle.

Several trials were undertaken in order to investigate which materials, covering material structures and laminating processes would produce cells best suited to the goals of solar vehicle racing. There were many challenges throughout this project as the sample modules created varied significantly from commercially manufactured cells. The results, however, suggest that ETFE50 plasma-treated films most effectively enhanced the bonding ability and the transmissibility of sample modules. These enhancements, in turn, improved the performance of the modules overall. Results also indicate that the sample modules responded well to the specific non-standard lamination process used in this project.

The Lumin II MK II solar racing vehicle had previously attempted the Bridgestone World Solar Car Challenge three times. The vehicle had used a commercially known method for constructing solar cells but it failed to complete the event each time. In 2019, the ETFE50 plasma-treated modules developed in this project were installed into the vehicle. Some minor mechanical changes were made to the vehicle at this time but compared to most other vehicles in the event the Lumin II MK II was mechanically underdeveloped and less aerodynamic. Nonetheless, for the first time, the Lumin II MK II successfully completed the 3000km event. It is clear that the cells developed in this project played a central role in the vehicle's completion of the event. Arguably, the cells produced in this project in combination with more advanced motor technology could produce a significantly more competitive solar racing vehicle.

11. Future work

11.1. Durability

Solar cell covering material is a critical aspect of a modules durability, specifically its ability to withstand moisture and UV degradation. The study of these factors requires an extended period of time that exceeds the one-year time limit for this project. This project did not assess the durability of the sample cells produced and used in the Lumin II MK II. The aim of the project was to maximise short-term power output, but future research might investigate how the durability of the project cells.

11.2. Lamination

This project utilised a standard lamination process using equipment lent from Tindo Solar. This was due to limitations in budget and equipment at the University of Adelaide. Using laminating equipment at Tindo Solar had implications for transportation, risks associated with damage due to transportation, accessibility, storage and general control of experimental conditions. This equipment was set to standard specifications for heat, suction and pressure and use of the equipment was subject to permission from Tindo Solar. As a result, this project could not explore how varying different elements within the lamination process might impact solar cell performance. Future work might seek out opportunities to explore variations in the lamination process. Renewables System Technology (2019) provides plans for the construction of a laminating machine that could be adjusted beyond standardised settings. During the research, it was found the plans and the design of the lamination machine. The machine could have been assembled if the time and the budget were provided. The link is provided in the references. (renewablesystemstechnology 2019)

11.3. Teflon Sheet Variations

The teflon mesh is an important part of ensuring solar cells are encapsulated sufficiently without wrinkles. However, during this project, the use of Teflon mesh according to commercial standard proved problematic and directly resulted in damage to cells. While the Teflon mesh was utilised according to commercial parameters the sample modules and cells were not commercial panels. For this reason, it is important to explore the use of non-standard Teflon mesh parameters in order to assess its impact on solar cell condition.

12. Reference

Altenergy 2019, Common Types of Solar Cells, Alternative energy, viewed 12 October 2019 <<http://www.altenergy.org/renewables/solar/common-types-of-solar-cells.html>>

Ali Nasr Allah Ali, Mohamed H. Saied, M. Z. Mostafa, T. M. Abdel- Moneim 2012, A survey of maximum PPT techniques of PV systems, Research gate , viewed 3 October 2019, <https://www.researchgate.net/publication/261051521_A_survey_of_maximum_PP_T_techniques_of_PV_systems>.

Askari Mohammad Bagher, Mirzaei Mahmoud Abadi Vahid, Mirhabibi Mohsen 2015, Types of Solar Cells and Application, American Journal of Optics and Photonics, viewed 10 October 2019, <<http://article.sciencepublishinggroup.com/html/10.11648.j.ajop.20150305.17.html>>

Battery conditioning tips 2016, Types of Rechargeable Batteries, viewed 29 October 2019 < <http://www.batteryreconditioningtips.com/types-rechargeable-batteries/> >

Curbell Plastics 2019, ETFE, Curbell Plastics, Viewed 16 May 2019<<https://www.curbellplastics.com/Research-Solutions/Materials/ETFE>>

DuPont 2019 , Solar PV Backsheets: A Key Contributor in Ensuring Lifetime and Power Output, DuPont 2019 , viewed on 21 May 2019< <https://www.dupont.com/products-and-services/solar-photovoltaic-materials/photovoltaic-backsheet-films/products/tedlar-backsheets.html>>

JBAO 2019, YingKou Jinchen-Automated production line for photovoltaic cell module, JBAO Tech, viewed 11 May 2019 <<http://www.jbao-tech.com/En/ProductView.asp?ID=278>>

Kiran Ranabhat , Leev Patrikeev , Aleksandra Antal'evna Revina, Kirill Andrianov, Valerii Lapshinsky , Elena Sofronova 2016, AN INTRODUCTION TO SOLAR CELL TECHNOLOGY, Journal of Applied Engineering Science viewed 18 August 2019 <<https://scindeks-clanci.ceon.rs/data/pdf/1451-4117/2016/1451-41171604481R.pdf> >

Michelle Bowman, Owen Comstock, Michael Mobilia 2017, Solar eclipse on August 21 will affect photovoltaic generators across the country US energy information administration viewed 17 October 2018 < <https://www.eia.gov/todayinenergy/detail.php?id=32372>>

National Renewable energy technology 2018, best research cell efficiencies, National Renewable energy technology, viewed 17 October 2018<<https://www.nrel.gov/pv/assets/pdfs/best-research-cell-efficiencies.20191106.pdf> >

NASA Technology transfer program 2019, High-Efficiency Solar Cell, NASA Technology transfer program, viewed 17 August 2019 < <https://technology.nasa.gov/patent/LEW-TOPS-50> >

PV education 2019, Module material, PV education, viewed 15 May 2019<<https://www.pveducation.org/pvcdrom/modules-and-arrays/module-materials>>

Recharge Batteries 2019, Better Technology, viewed 6 October 2019 <<https://www.rechargebatteries.org/about-batteries/technologies/> >

Renewablesystemstechnology 2019, BUILD A DIY SOLAR PANEL LAMINATOR, Renewable systems technology viewed 28 Feb 2019<<https://renewablesystemstechnology.com/solar-panel-laminator.html> >

Ronald Brakels 2019, Solar Panel Backsheet Defects Rising Says DuPont PV Reliability Report , Solar quotes, viewed 20 July 2019 <<https://www.solarquotes.com.au/blog/solar-panel-backsheet-defects/>>

RTP Company 2019, polyvinylidene-fluoride PVDF, RTP Company, Viewed 16 May 2019<<https://www.rtpcompany.com/products/product-guide/polyvinylidene-fluoride-pvdf/>>

Sinovoltaics Group 2019, Electroluminescence EL testing, Sinovoltaics group, viewed 28 October 2019 <<https://sinovoltaics.com/electroluminescence-el-testing/>>

SpecialChem 2019, Polyethylene Terephthalate (PET): A Comprehensive Review, SpecialChem, viewed May 16, 2019 <<https://omnexus.specialchem.com/selection-guide/polyethylene-terephthalate-pet-plastic>>

S S Verma 2016, NEXT GENERATION SOLAR CELLS, Akshay Urja Magazine, viewed 10 July 2019 < <https://mnre.gov.in/file-manager/akshay-urja/october-2016/21-25.pdf> >

Tindo Solar 2019, viewed 7 October 2019, <<https://www.tindosolar.com.au>>.

V.Jafari Fesharaki, Majid Dehghani, J. Jafari Fesharaki Hamed Tavasoli 2011, The Effect of Temperature on Photovoltaic Cell Efficiency , Emerging Trends in Energy Conservation, viewed 18 August 2019 <http://research.iaun.ac.ir/pd/jjfesharakiold/pdfs/PaperC_4124.pdf>

13. Appendix

A. Budget and part list

Attached to this document.

B. Project Gant chart

Attached to this document.

C. Race Data (from chase laptop).

Attached to this document.

D. Outdoor testing code and results

Attached to this document.

E. Solar cells datasheet

Attached to this document.