



FRAGILE SITES ON HUMAN CHROMOSOME 16: A LINKAGE ANALYSIS STUDY

A thesis submitted to the University of Adelaide
for the degree of Doctor of Philosophy,

by

ANTONIO FRATINI, B.Sc. (Hons.)

Department of Paediatrics,
University of Adelaide,
South Australia.

November, 1988.

To my dear wife, Maria.

FRAGILE SITES ON HUMAN CHROMOSOME 16: A LINKAGE ANALYSIS STUDY

TABLE OF CONTENTS

	PAGE
THESIS SUMMARY	i
STATEMENT	v
ACKNOWLEDGEMENTS	vi
ABBREVIATIONS	vii
PREFACE	viii

CHAPTER 1

INTRODUCTION

1.1	PRELIMINARY COMMENTS.	1
1.2	GENETIC POLYMORPHISMS IN THE HUMAN GENOME.	1
1.2.1	DEFINITION OF GENETIC POLYMORPHISM.	1
1.2.2	THE IMPORTANCE OF GENETIC POLYMORPHISMS FOR GENETIC ANALYSES.	2
1.3	BLOOD GROUP, ENZYME AND PROTEIN POLYMORPHISMS.	3
1.3.1	EXTENT OF POLYMORPHISM IN THE HUMAN GENOME.	4
1.3.2	LIMITATIONS IN THE USE OF BLOOD GROUP, ENZYME AND PROTEIN POLYMORPHISMS.	5
1.4	DNA POLYMORPHISMS IN THE HUMAN GENOME.	6
1.4.1	THE MOLECULAR BASIS FOR POLYMORPHISMS.	6
1.4.2	DNA POLYMORPHISMS.	7
1.4.3	THE DETECTION OF RFLPS.	8
1.4.4	SOURCE OF DNA PROBES THAT IDENTIFY RFLP LOCI.	10
1.4.5	OPTIMIZING THE SEARCH FOR RFLPS.	12
1.4.6	USE OF RFLPS FOR GENETIC ANALYSES.	13

1.4.7	CONSTRUCTION OF A HUMAN GENOME RFLP LINKAGE MAP.	17
1.4.8	METHODS TO CLONE DISEASE LOCI MAPPED BY LINKED RFLPS.	18
1.4.9	HYPERVARIABLE REGIONS IN THE HUMAN GENOME.	19
1.4.10	SUMMARY.	21
1.5	FRAGILE SITES IN THE HUMAN GENOME.	22
1.5.1	DEFINITION OF A FRAGILE SITE.	22
1.5.2	DISCOVERY OF FRAGILE SITES.	23
1.5.3	FEATURES OF FRAGILE SITES.	24
1.5.4	CLASSIFICATION OF FRAGILE SITES.	26
1.5.5	THE RARE FRAGILE SITES.	27
1.5.5.1	THE FOLATE SENSITIVE FRAGILE SITES.	27
1.5.5.2	THE BRDU INDUCED FRAGILE SITE.	32
1.5.5.3	THE DISTAMYCIN A INDUCIBLE FRAGILE SITES.	32
1.5.6	THE COMMON FRAGILE SITES.	34
1.5.7	GENERAL AIMS OF THE THESIS.	35
1.5.7.1	SPECIFIC AIMS OF THE THESIS.	37

CHAPTER 2

MATERIALS AND GENERAL METHODS

2.1	MATERIALS.	39
2.1.1	CHEMICALS AND REAGENTS.	39
2.1.2	ENZYMES.	40
2.1.3	BUFFERS.	40
2.1.4	BACTERIAL MEDIA.	40
2.1.5	BACTERIAL STRAINS.	41
2.1.6	CLONING VECTORS.	41
2.1.7	NUCLEIC ACIDS AND CLONED DNA SEQUENCES.	42

2.1.8	HYBRID CELL LINES.	42
2.1.9	UTAH FAMILIES.	42
2.1.10	FRAGILE SITE FAMILIES.	43
2.1.11	MISCELLANEOUS MATERIALS.	43
2.2	GENERAL METHODS.	43
2.2.1	PREPARATION OF GLASSWARE AND SOLUTIONS.	43
2.2.2	PHENOL, CHLOROFORM-ISOAMYLALCOHOL EXTRACTIONS.	44
2.2.3	ETHANOL PRECIPITATION.	44
2.2.4	PREPARATION OF HIGH-MOLECULAR-WEIGHT GENOMIC DNA.	44
2.2.4.1	ISOLATION FROM HUMAN BLOOD.	45
2.2.4.2	ISOLATION FROM CELL LINES.	45
2.2.5	PREPARATION OF RECOMBINANT PHAGE DNA.	46
2.2.6	PREPARATION OF RECOMBINANT PLASMID DNA.	47
2.2.6.1	LIQUID CULTURE METHOD.	47
2.2.6.2	PLATE ISOLATION METHOD.	48
2.2.7	QUANTITATION OF DNAs.	49
2.2.8	RESTRICTION ENDONUCLEASE DIGESTIONS OF DNA.	49
2.2.9	AGAROSE GEL ELECTROPHORESIS OF DNA.	50
2.2.10	ISOLATION OF DNA FRAGMENTS FROM AGAROSE GELS.	50
2.2.11	TRANSFER OF DNA TO GENESCREEN PLUS.	51
2.2.12	PREPARATION OF RADIOACTIVE DNA PROBES.	51
2.2.12.1	NICK-TRANSLATION OF DOUBLE-STRANDED DNA.	51
2.2.12.2	OLIGO-LABELLING OF DNA RESTRICTION FRAGMENTS.	51
2.2.13	PRE-REASSOCIATION OF REPETITIVE DNA CLONES.	52
2.2.14	HYBRIDIZATION OF RADIOACTIVE DNA PROBES.	52
2.2.15	SUBCLONING OF DNA FRAGMENTS INTO PLASMID VECTORS.	53
2.2.15.1	PREPARATION OF VECTOR DNA.	53
2.2.15.2	PREPARATION OF INSERT DNA.	54
2.2.15.3	DNA LIGATIONS.	54

2.2.15.4	BACTERIAL TRANSFORMATIONS.	54
2.2.15.5	DETECTION OF RECOMBINANT PLASMIDS.	55
2.2.16	COMPUTER PROGRAMS.	55
2.2.17	CONTAINMENT FACILITIES.	55

CHAPTER 3

CONSTRUCTION AND SCREENING OF THE CY17 RECOMBINANT LIBRARY

3.1	INTRODUCTION.	56
3.2	METHODS.	58
3.2.1	SOUTHERN BLOT ANALYSIS OF CY17.	58
3.2.2	PREPARATION OF THE CY17 GENOMIC LIBRARY.	59
3.2.3	SCREENING OF THE CY17 GENOMIC LIBRARY.	59
3.2.4	RESTRICTION ANALYSIS OF RECOMBINANT CLONES.	60
3.3	RESULTS.	61
3.4	DISCUSSION.	61
3.5	SUMMARY.	63

CHAPTER 4

PHYSICAL MAPPING OF CLONES FROM THE CY17 RECOMBINANT LIBRARY

4.1	INTRODUCTION.	65
4.2	METHODS.	65
4.2.1	INITIAL MAPPING OF CLONES ONTO CHROMOSOMES 16 AND 22.	65
4.2.2	REGIONAL MAPPING OF CHROMOSOME 16 CLONES.	66
4.2.3	<u>IN SITU</u> HYBRIDIZATION OF CHROMOSOME 16 CLONES.	66
4.3	RESULTS.	66
4.4	DISCUSSION.	68

4.4.1	CLONES FROM THE CY17 LIBRARY.	68
4.4.2	REMAPPING OF HUMAN ADENINE PHOSPHORIBOSYLTRANSFERASE.	70
4.5	SUMMARY.	71

CHAPTER 5

SEARCH FOR RFLPS WITH THE CHROMOSOME 16 CLONES

5.1	INTRODUCTION.	72
5.2	METHODS.	72
5.2.1	SEARCH FOR RFLPS.	72
5.2.2	MENDELIAN INHERITANCE AND ALLELE FREQUENCIES OF RFLPS.	72
5.2.3	SUBCLONING OF CLONES DETECTING RFLPS.	72
5.2.3.1	SUBCLONING λ 247 (<u>D16S8</u>).	72
5.2.3.2	SUBCLONING λ 221 (<u>D16S10</u>).	74
5.3	RESULTS.	75
5.4	DISCUSSION.	76
5.5	SUMMARY.	78

CHAPTER 6

LINKAGE ANALYSIS STUDIES: THE UTAH FAMILIES

6.1	INTRODUCTION.	79
6.2	LINKAGE ANALYSIS.	79
6.3	METHODS.	81
6.3.1	PREPARATION OF FILTERS.	81
6.3.2	ADDITIONAL TYPING RESULTS.	82
6.4	RESULTS.	82
6.4.1	DNA TYPING RESULTS.	82

6.4.2	LINKAGE STUDIES WITH <u>D16S8</u> AND <u>D16S79</u> .	83
6.4.3	LINKAGE STUDIES WITH <u>D16S10</u> , <u>MT</u> , <u>D16S4</u> AND <u>HP</u> .	83
6.5	DISCUSSION.	84
6.5.1	16p LINKAGE GROUP.	84
6.5.2	16q LINKAGE GROUP.	84
6.5.3	GENERAL DISCUSSION.	85
6.6	SUMMARY.	86

CHAPTER 7

LINKAGE ANALYSIS STUDIES: THE FRAGILE SITE FAMILIES

7.1	INTRODUCTION.	87
7.2	METHODS.	87
7.3	RESULTS.	87
7.4	DISCUSSION.	88
7.5	SUMMARY.	90

CHAPTER 8

CONCLUDING DISCUSSION

8.1	CONCLUSIONS AND DISCUSSION.	92
-----	-----------------------------	----

BIBLIOGRAPHY	98
---------------------	-----------

APPENDIXES

APPENDIX A	PEDIGREES OF THE UTAH FAMILIES.	137
APPENDIX B	PEDIGREES OF THE INFORMATIVE FRAGILE SITE FAMILIES.	138

APPENDIX C	TYPING RESULTS IN UTAH FAMILIES 981, 982, 984 AND 985 WITH <u>D16S8</u> AND <u>D16S79</u> .	139
APPENDIX D	TYPING RESULTS IN UTAH FAMILIES 981, 984, 985 AND 1029 WITH <u>D16S4</u> AND <u>D16S10</u> .	142
APPENDIX E	TYPING RESULTS FOR <u>FRA16A</u> FAMILY 10556 WITH <u>D16S8</u> AND <u>D16S79</u> .	145
APPENDIX F	TYPING RESULTS FOR THE INFORMATIVE <u>FRA16B</u> FAMILIES WITH <u>D16S10</u> .	147
APPENDIX G	PAPERS PUBLISHED AND ACCEPTED FOR PUBLICATION.	150

THESIS SUMMARY

The aim of this study was to aid in the construction of a linkage map of human chromosome 16, using restriction fragment length polymorphisms (RFLPs) detected by anonymous DNAs, with emphasis in obtaining RFLPs linked to the fragile sites on this chromosome.

In order to provide a source of chromosome 16 DNA fragments to be screened for RFLP detection, a genomic λ Charon 4A EcoRI library was constructed from the mouse-human hybrid cell line CY17. When karyotyped, CY17 was found to contain human chromosome 16 in 59 percent of cells, human chromosome 22 in 28 percent of cells but no other identifiable human chromosomes. Southern blot analysis confirmed the presence of chromosome 16 and 22 sequences in CY17.

A total of 26,000 phages were plated out from the unamplified CY17 library and the plaques were probed with the cloned human Alu repeat sequence probe, pBLUR8. A total of 35 (0.14%) plaque purified human λ clones were obtained.

Thirteen clones were mapped to chromosome 16, 10 were mapped to chromosome 22, six did not map to either chromosome 16 or 22 and six clones produced uninterpretable autoradiographs and thus could not be mapped. One of the clones that mapped to chromosome 22, ACHF249 (D22S14), detected a PstI RFLP. No further analysis was done on the remaining chromosome 22 clones.

Eight of the chromosome 16 clones were further localized to various regions on chromosome 16 using a chromosome 16 hybrid cell panel. One clone mapped from 16pter- \rightarrow 16p13.11, two clones mapped from 16p13.3- \rightarrow 16p13.11, one clone mapped from 16p13.11- \rightarrow 16q13, three clones mapped from 16q13- \rightarrow 16q22.1 and one clone mapped from 16q22.1- \rightarrow 16q24.

Six of the regionally assigned chromosome 16 clones were used to

screen for RFLPs using a panel of six random human genomic DNAs digested with up to 23 different restriction endonucleases.

Two of the clones, λ 247 (D16S8) and λ 221 (D16S10), detected RFLPs. λ 247 detected a PvuII RFLP and had a polymorphic information content (PIC) of 0.38. λ 221 detected RFLPs with RsaI and TaqI and had a PIC of 0.36. The RsaI and TaqI RFLPs displayed linkage disequilibrium. The subclone from pACHF1 (D16S8), pACHF1.1, detected the PvuII RFLP but still contained repeat sequences. The subclone from λ 221 (D16S10), pACHF3.5, detected both RsaI and TaqI RFLPs.

λ 247 was mapped, by the use of the chromosome 16 hybrid cell panel, to 16p13.3- \rightarrow p13.11, and λ 221 was mapped to 16q13- \rightarrow q22.1. λ 247 was further localized by *in situ* hybridization as being distal to FRA16A (Callen *et al.*, 1988b) and λ 221 was proximal to FRA16B (Callen *et al.*, 1988a).

Both clones were used to type the Utah families for linkage analysis with other RFLPs that mapped near to FRA16A and FRA16B. The Utah families consisted of three generations, each having both sets of grandparents and parents with at least six offspring.

D16S8 was used to type a family in which FRA16A was segregating and D16S10 was used to type families in which FRA16B was segregating to determine if the loci were linked to these fragile sites.

The anonymous DNA clone, 36-1 (D16S79) (Breuning *et al.*, 1988), was mapped to the same region as D16S8 and both markers showed tight linkage with a maximum lod score (\hat{z}) of 6.90 at the most likely recombination fraction ($\hat{\theta}$) of 0.08. This corresponded to a map distance of between 2-20 cM (90% confidence level) between D16S8 and D16S79.

No recombinants were observed between FRA16A and D16S8 ($\hat{z} = 2.84$, $\hat{\theta} = 0.00$). One individual in the FRA16A family was a recombinant between D16S79 and FRA16A and a recombinant between D16S8 and D16S79, but was

not a recombinant between D16S8 and FRA16A. This gave the likely loci order as: 16pter-D16S79-D16S8-FRA16A-cen. D16S8 was the closest polymorphic DNA locus distal to FRA16A.

No recombinants were found in the MT, D16S10-D16S4-HP cluster from the informative Utah sibships. The polymorphic anonymous DNA clone, ACH207 (D16S4) (Hyland *et al.*, 1988b), was mapped distal to FRA16B (Callen *et al.*, 1988a). There were no recombinants out of 29 informative meioses between D16S4 and D16S10. The maximum lod score and most likely recombination fraction between D16S4 and D16S10 was $\hat{z} = 8.30$, $\hat{\theta} = 0.00$. This corresponded to a map distance of between 0-7 cM (90% confidence level) between D16S4 and D16S10. D16S10 was linked to HP ($\hat{z} = 2.96$, $\hat{\theta} = 0.00$).

There were insufficient informative meioses to establish the map distances between MT and D16S10 and between FRA16B and D16S10.

In conjunction with the known physical localizations of the probes, the most likely loci order around FRA16B was: cen-MT, D16S10-FRA16B-D16S4-HP-qter. The MT, D16S10-FRA16B-D16S4-HP linkage group was the first tight linkage group around an autosomal fragile site. MT and $\lambda 221$ (D16S10) were the closest proximal polymorphic DNA markers to FRA16B.

This study has made a useful contribution in the isolation of polymorphic markers to be used in the construction of a chromosome 16 linkage map. Two useful anonymous DNA clones, $\lambda 247$ (D16S8) and $\lambda 221$ (D16S10), were isolated from the CY17 library. D16S8 was the closest distal locus to FRA16A and D16S10 was one of the closest proximal loci to FRA16B. D16S10 was tightly linked to the closest polymorphic distal locus (D16S4) to FRA16B.

The established linkage groups around FRA16A and FRA16B can be used for the mapping and ordering of additional RFLPs with respect to these fragile sites. Many tightly linked and flanking RFLPs would be required

for the development of detailed genetic maps that may aid the eventual cloning of the fragile sites on this chromosome.

The human gene for adenine phosphoribosyltransferase (APRT) was remapped from 16q22.2->q22.3 to 16q24. This resolved an inconsistency in the localization of APRT by several groups, and explained the reported absence of linkage between APRT and HP and the absence of linkage between FRA16B and APRT.

STATEMENT

This thesis contains no material which has been accepted for the award of any other degree or diploma by any other University. To the best of my knowledge, it contains no material that has previously been published by any other person except where due reference is made in the text. I consent to the thesis being made available for photocopying and for loan.

Signed

ANTONIO FRATINI

ACKNOWLEDGEMENTS

I wish to thank Dr. R.F. Carter for permission to work in the Department of Histopathology, Adelaide Children's Hospital.

I sincerely thank my supervisors, Professor G.M. Maxwell and Dr. G.R. Sutherland for their advice, criticisms and encouragement throughout the course of this work.

I thank my colleagues for their stimulating discussions and for creating an enthusiastic atmosphere in which to work - Elizabeth Baker, Lyndall Bates, Dr. David Callen, Agi Gedeon, Scott Grist, Jenny Hall, Dr. Val Hyland, Dr. Ruth MacKinnon, Dr. John Mulley, Dr. Arnis Puspurs, Dr. Ieva Stupans and Dr. Graeme Suthers.

I am especially grateful to Dr. Val Hyland and Dr. Arnis Puspurs for their advice and help in the screening of the CY17 library; to Jenny Hall for her technical assistance; to Dr. David Callen for the provision of the chromosome 16 mapping panel; to Elizabeth Baker and Dr. David Callen for the provision of the in situ hybridization results presented in Chapter 4 and to Dr. Val Hyland, Agi Gedeon and Lyndall Bates for the DNA typing results presented in Chapter 6.

I wish to thank Roland Hermanis for the photography and to my sister-in-law, Angela Dell'olio, for the typing of this thesis.

I thank my parents for giving me the opportunity to study and my in-laws, Mr. and Mrs. D. Dell'olio, for their encouragement.

Finally I am deeply indebted to my wife, Maria, for her constant support, patience and understanding and to my baby son, Julian, who provided lots of laughs and nappy changes during the course of writing!

I was supported during this work by grants from the National Health and Medical Research Council of Australia to Dr. G.R. Sutherland and by a Commonwealth Postgraduate Research Award.

ABBREVIATIONS

bp	-	nucleotide base pairs.
BSA	-	bovine serum albumin.
CEPH	-	Centre d'Etude du Polymorphisme Humain.
Ci	-	Curie.
cM	-	centiMorgan.
cpm	-	counts per minute.
DNase	-	deoxyribonuclease.
dNTP	-	2'-deoxynucleoside-5'-triphosphate.
DTT	-	dithiothreitol.
HVR	-	hypervariable region.
kb	-	kilobase pairs.
PEG	-	polyethylene glycol
PIC	-	polymorphic information content.
pfu	-	plaque forming units.
PVP	-	polyvinylpyrrolidone.
RFLP	-	restriction fragment length polymorphism.
RNase	-	ribonuclease.
rpm	-	revolutions per minute.
SDS	-	sodium dodecyl sulphate.
shDNA	-	sonicated human Deoxyribonucleic acid.
smDNA	-	sonicated mouse Deoxyribonucleic acid.
UV	-	ultra-violet.
VNTR	-	variable number of tandem repeat.

PREFACE

Much of the work presented in this thesis has been published, accepted for publication or submitted for publication. The papers that have been published or accepted for publication are appended (Appendix G). All the chapters presented in this thesis are largely self-contained, however it is suggested that the reader will obtain a clearer picture of the work carried out if the relevant papers are read before each chapter.

CHAPTER 1
INTRODUCTION



1.1 PRELIMINARY COMMENTS

All human beings are diverse in their physical, physiological and mental attributes and in their susceptibility to various types of diseases and abnormalities (Cavalli-Sforza and Bodmer, 1971). These variations are due to both genetic (heritable) and environmental components unique to each individual and to the complex interaction between these two components (Weiss, 1950).

The genetically determined differences, detected as variations in the sequence of genomic DNA (RFLPs), are highly suited for the study of human chromosome 16 and the fragile sites on this chromosome.

This chapter is divided into four main sections. The first section defines what a genetic polymorphism is and how they are utilized in genetic analyses, such as gene mapping by linkage analysis. Section two is a brief outline of the discovery, uses and limitations of genetic polymorphisms found in blood groups, enzymes and proteins.

Section three is an account of the discovery of genetic polymorphisms in human genomic DNA and how recombinant DNA technology has exploited this new source of variability for the purpose of genetic analyses.

Section four details the main subject matter of this study, fragile sites on human chromosomes, as well as the main aims of this thesis.

1.2 GENETIC POLYMORPHISMS IN THE HUMAN GENOME

1.2.1 DEFINITION OF GENETIC POLYMORPHISM

Classical genetic studies led to the concept of the gene as the fundamental biological unit of heredity (reviewed in Stent, 1971). An essential criterion for this concept was that the gene had to be susceptible to occasional mutations that could result in the appearance of distinct new forms (alleles) differing from the original in the population.

The allelic forms of genes allow individual members of a natural population to 'differ' from one another, the extent of which depends on the number of alleles present at the various loci and the relative frequencies with which they occur. If the alleles at a specific locus occur in a population with 'appreciable frequencies' the phenomena is referred to as a genetic polymorphism.

A genetic polymorphism is defined as the occurrence of two or more alternate alleles for a given locus in a population, where the least common allele occurs with a frequency which can not be maintained by mutation alone. In practice this is taken as an allele frequency of more than one percent (Ford, 1964). Any allele occurring with a frequency of less than one percent is referred to as a rare variant.

1.2.2 THE IMPORTANCE OF GENETIC POLYMORPHISMS FOR GENETIC ANALYSES

Genetic polymorphisms provide a way to distinguish between two or more forms of specific loci in the genome, and hence can be used as specific 'markers' for various genetical analyses (Harris, 1980). The ability to follow the inheritance of genetic marker loci in families is of particular importance for:-

- (1) Gene mapping of disease loci by linkage analysis.
- (2) Diagnosis of human genetic disease.
- (3) The initial steps towards the identification and characterization of the genes for which the gene product is unknown.
- (4) The analysis of complex disorders in which environmental and genetic factors combine.

The usefulness of a polymorphic genetic marker depends on:-

- (1) A simple and unequivocal pattern of inheritance.
- (2) Accurate identification of each phenotype.

(3) A high frequency of heterozygosity.

Botstein et al. (1980) devised a mathematical expression (the PIC value) to calculate the usefulness of a marker for linkage studies. The PIC value is the sum of the frequency of each mating type multiplied by the probability that the offspring of that mating would be informative in linkage studies. Markers are placed into three categories based on their PIC value, which ranges from between zero (uninformative) to one (fully informative):-

- (1) $0.5 > \text{PIC} < 1.0$: marker is highly informative.
- (2) $0.5 > \text{PIC} > 0.25$: marker is reasonably informative.
- (3) $0.0 > \text{PIC} < 0.25$: marker is slightly informative.

In general, loci with the greatest number of alleles have the highest PIC values and are the most desirable for linkage studies (Botstein et al., 1980; Ott, 1986; White et al., 1985a).

Genetic polymorphisms in humans have been discovered in blood group substances, enzymes, serum proteins (1.3) and in genomic DNA (1.4.6).

1.3 BLOOD GROUP, ENZYME AND PROTEIN POLYMORPHISMS

Prior to the advent of recombinant DNA technology (Wu, 1979) the majority of polymorphisms detected in humans, determined by various immunological (Boettcher, 1972) and electrophoretic (Harris and Hopkinson, 1978) techniques, were those of the white and red blood-cell proteins and serum proteins (Vogel and Motulsky, 1982). The discovery of the large number of human blood group, enzyme and protein polymorphisms has been of enormous value in the study of human diseases (Harris, 1980).

The first genetic polymorphism defined in humans was the ABO blood

group system (Landsteiner, 1900). Since Landsteiner's discovery, more than 30 different human blood groups have been identified by immunological methods, of which 30 percent are polymorphic (Lewontin, 1967). Blood group polymorphisms have been utilized in disease association studies in humans (Mourant et al., 1978) and for linkage analyses (Mulley, 1985a; Race and Sanger, 1975).

The advent of starch-gel electrophoresis (Smithies, 1955), coupled with the histochemical staining for specific enzymes (Hunter and Market, 1957), has allowed for the analysis of a large number of enzymes and proteins in humans (Harris and Hopkinson, 1978). A number of these are polymorphic (Harris and Hopkinson, 1978) and several are associated with specific genetic diseases, an example being the PI (protease inhibitor) locus and its association with α_1 -antitrypsin deficiency (Fagerhol and Cox, 1981).

1.3.1 EXTENT OF POLYMORPHISM IN THE HUMAN GENOME

In order to investigate the degree of polymorphism in humans, Harris (1969) screened individuals for normal and altered electrophoretic forms of 18 unselected red blood cell and serum enzymes and found that six were polymorphic. The findings suggested that approximately 67 percent of loci coding for enzymes and proteins were invariant. The value of 33 percent variability probably was an underestimate on the degree of protein polymorphism present, due to the limitations of the electrophoresis technique (reviewed in Harris, 1980).

Of the 104 loci coding for enzymes examined in human populations, 24 were found to be polymorphic (Harris, 1980). The average heterozygosity per locus for the polymorphic alleles was calculated to be 0.063, implying that any individual from the population was likely to be heterozygous at about six percent of the loci tested (Harris, 1980).

Neel (1984) recalculated the amount of heterozygosity for protein polymorphisms as being between 12-13 percent, by taking into account the development of new and more sensitive electrophoretic techniques.

1.3.2 LIMITATIONS IN THE USE OF BLOOD GROUP, ENZYME AND PROTEIN POLYMORPHISMS

The degree of polymorphism in the human genome varies enormously from one locus to another (Botstein et al., 1980). Of the 29 established human polymorphic protein markers routinely used for genetic analyses, four were highly informative, 15 reasonably informative and 10 were slightly informative (Botstein et al., 1980). Twenty of the markers were polymorphic enough to be considered useful in genetic analyses. However, because of low PIC values, many of the markers would be uninformative in linkage studies in a large number of families.

If the 20 protein markers were evenly spaced in the genome, they would span only 800 of the 3,300 cM of the human genome (Botstein et al., 1980). The human genome is therefore scantily covered in polymorphic blood group, enzyme and protein markers, making the mapping and eventual isolation of the 4,000 or so known disease loci (McKusick, 1986) difficult to achieve.

Enzyme electrophoresis has been used to assign particular gene loci to specific chromosomes or regions of chromosomes by either somatic cell hybrid studies (Ruddle, 1973) or by the analysis of pedigrees in which alleles at two or more loci are segregating (Renwick, 1971). The number of polymorphic and non-polymorphic loci being mapped using these methods are increasing (McKusick, 1986), however it represents only five percent or less of the 50,000 to 100,000 possible structural genes that the human genome is capable of coding for (O'Brien, 1973). The structural genes constitute a small percentage of the 3×10^9 bp estimated to be

in the human haploid genome (Mendelsohn et al., 1973).

Since most of these diseases have no known phenotype in cultured cells, they cannot be localized to specific chromosomes using hybrid cell mapping approaches (Ruddle, 1973). Their position in the genome can be determined by co-segregation in families with linked genetic markers of known locations (1.4.7). In order to systematically map loci by linkage analysis a large number of evenly spaced, highly polymorphic markers are required in the human genome (Botstein et al., 1980).

These essential criteria are not met by the existing blood group, enzyme and protein markers. The use of such markers for genetic studies in humans are becoming redundant following the recent discovery of genomic DNA sequence polymorphisms which are highly suited for the mapping of such loci (Botstein et al., 1980; White et al., 1985a).

1.4 DNA POLYMORPHISMS IN THE HUMAN GENOME

1.4.1 THE MOLECULAR BASIS FOR POLYMORPHISMS

The first direct evidence that a gene mutation could result in the synthesis of an altered human protein came from the work on haemoglobin in the condition called sickle-cell anemia. Pauling et al. (1949) demonstrated that the normal haemoglobin (HbA) protein could be electrophoretically separated from the abnormal sickle cell haemoglobin (HbS) protein. Ingram (1957) showed that this was due to just one amino acid change in the β -globin chain of haemoglobin.

The nucleotide sequence of the mRNA for the β -globin chain of normal human haemoglobin (Forget, 1977) allowed the nature of the mutational change to be precisely defined for HbS gene, as well as for all the other allelic variants of β -globin (Antonarakis et al., 1985). The single base pair change that resulted in the HbA \rightarrow HbS mutation, as

well as the other β -globin variants, implied that the nucleotide base pair was the smallest unit of inherited variation. From the detailed work of the globin genes, as well as from the analysis of other genes (Harris, 1980), the results showed that the human genome contained an enormous amount of variation that could be potentially utilized for genetic analyses (Botstein *et al.*, 1980).

Recombinant DNA technology has had an enormous impact on molecular biology because it allows the isolation and analysis of virtually any segment of DNA (Wu, 1979). This technology has given the investigator the means to access and exploit this new source of variability.

1.4.2 DNA POLYMORPHISMS

Previously, the analysis of the molecular basis of human genetic disorders was to attempt to isolate and purify the mRNA or the gene products of the implicated disease gene, and then try to determine the associated clinical change (Davies, 1981). For example, the precise molecular descriptions of the thalassemia syndromes relied on the isolation of the affected proteins, the globins (Loukopoulos, 1985). The difficulty in extending this approach to all heritable traits and diseases is that the vast majority of such genes are known only by their phenotype (McKusick, 1986).

Recombinant DNA technology has led to the development of a new system of DNA genetic markers (RFLPs, HVRs and minisatellites) in humans that enable the mapping of virtually any inherited trait (Botstein *et al.*, 1980; Jeffreys *et al.*, 1985a; White *et al.*, 1985a). These markers reveal the natural genetic variation in the DNA sequence amongst individuals that are detected by DNA restriction enzymes (Kessler and Holtke, 1986; Nathans and Smith, 1975).

Restriction enzyme site polymorphisms occur once in every 100 to

200 bp around the A γ -, G γ -, δ - and β -globin genes in man (Jeffreys 1979). At this rate, there are potentially between 10^7 (Cooper et al., 1985) and 3×10^7 polymorphic loci in the human genome (Jeffreys, 1979).

The extent of genetic variation, detected by restriction enzymes, is approximately 10 times that detected through studies of proteins (Nei, 1975), suggesting that most of the polymorphic variation present in the genome occurs in non-coding DNA sequences (Cooper et al., 1985).

Of the 15 restriction site polymorphisms found in the β -globin gene complex, 10 were in flanking DNA, three in intervening sequences, one in a pseudogene and only one in a coding sequence (Chakravarti et al., 1984).

Genomic DNA sequence variations have also been detected by:-

- (1) Denaturing gradient gel electrophoresis (Fischer and Lerman, 1983).
- (2) Direct sequencing of enzymatically amplified human genomic DNA by polymerase chain reaction (PCR) (Engelke et al., 1988).
- (3) DNA sequence analysis (Antonarakis et al., 1985).
- (4) Ribonuclease A cleavage of RNA:DNA or RNA:RNA duplexes (Myers et al., 1985).
- (5) Sequencing cloned mRNA from patients with inborn errors of metabolism (Valerio et al., 1986).
- (6) Synthetic oligonucleotide probes (Kidd et al., 1983).

Of these techniques, DNA restriction enzyme analysis is the most straightforward and applicable approach to screen for sequence variation in genomic DNA (Gusella, 1986).

1.4.3 THE DETECTION OF RFLPS

The methodology most commonly employed to visualize DNA sequence

polymorphism is by Southern blot analysis (Southern, 1975). This procedure consists of four basic steps:-

- (1) Genomic DNA from a set of unrelated individuals is cleaved with a DNA restriction enzyme, and fractionated according to size by electrophoresis through an agarose gel.
- (2) Denaturation of the DNA and transfer to a solid support (filter) such as nitrocellulose or nylon membrane.
- (3) Hybridization of the filter with a cloned segment of DNA (1.4.4) labelled with ^{32}P or biotin (Cunningham and Mundy, 1987). Washing of filter to remove any nonspecifically bound ^{32}P -labelled DNA and exposure to X-ray film, or processing of filter in the case of a biotin-labelled probe (Dykes *et al.*, 1986).
- (4) Any polymorphism is inferred from the differences, if any, between individuals in the pattern of restriction fragment lengths displayed on the autoradiograph or the processed filter. This difference in restriction fragment length is referred to as an RFLP.

An RFLP is defined by two factors, a probe which identifies the locus and the restriction enzyme used to provide fragments for a population sample to define alleles. The differences among individuals in the lengths of a specific restriction fragment result from either the loss of a cleavage site or formation of a new one, due to a point mutation in the DNA, or the insertion or deletion of blocks of DNA within a fragment.

It is important to demonstrate a Hardy-Weinberg distribution of genotypes and Mendelian inheritance and segregation of alleles, to prevent a mis-identification of an RFLP that may occur from varying

degrees of partial digestion (Skolnick and White, 1982).

Southern blot analysis can demonstrate polymorphism of DNA fragments that range from 1 to 20 kb (Botstein et al., 1980). It is possible to resolve smaller and much larger fragment lengths by using different gel systems and electrophoresis conditions. Polymorphisms have been identified with fragments that range from 10 to several 100 bps (Kreitmand and Aguade, 1986) and with fragments in the hundreds of kb (Julier and White, 1988) using pulsed-field gel electrophoresis (Schwartz and Cantor, 1984).

Murray et al. (1987) have described an RFLP screening technique that involves comparing the restriction pattern of DNA from a hybrid cell line containing a single human chromosome of single clonal origin, against pooled samples of DNA from 10 unrelated individuals. The DNA from the cell line is hemizygous for all RFLPs specific for the human chromosome. If a second allele is present in the pooled DNAs this will be seen as a band on a Southern blot not present in the DNA from the cell line. The advantage of this method is that a large number of enzymes can be screened for the detection of RFLPs while only requiring one human 'genomic mix' lane instead of 6-10 separate ones.

1.4.4 SOURCE OF DNA PROBES THAT IDENTIFY RFLP LOCI

DNA probes used to identify RFLP loci in the human genome have been isolated from:-

- (1) Total genomic DNA λ phage (Kao et al., 1982) or cosmid libraries (Litt and White, 1985).
- (2) Chromosome specific λ phage (Gusella et al., 1980) or cosmid libraries (Bufton et al., 1986).
- (3) cDNA clones from tissue specific cDNA libraries (Balazs et al., 1984; Helentjaris and Gesteland, 1983).

- (4) Specific chromosome λ phage libraries which have been prepared after fluorescence activated cell sorting (FACS) of the chromosomes (Davies et al., 1981; Van Dilla et al., 1986).
- (5) Gene-specific probes - cDNA or genomic DNA clones from genes of known function (Cooper and Schmidtke, 1986, 1987).

The most widely used probes for RFLP analyses are anonymous DNA probes - arbitrarily chosen single-copy cloned segments of DNA derived from various cDNA and genomic libraries. The clones are selected from these libraries by:-

- (1) Random isolation of cDNA clones from a human cDNA library (Helentjaris and Gesteland, 1983).
- (2) Identifying and then discarding clones, from total human genomic libraries, containing significant repetitive sequences by hybridization to human genomic DNA (Kao et al., 1982). Clones not hybridizing to the human genomic DNA are either single-copy or moderately repetitive.
- (3) Identifying clones containing human as opposed to rodent repetitive sequences from somatic cell hybrid libraries, by hybridization to either human genomic DNA (Gusella et al., 1980) or with the cloned human Alu repetitive sequence (pBLUR8) (Jelinek et al., 1980). The clones are then subcloned to remove the repetitive sequences.
- (4) Identifying and retrieving human clones from rodent-human somatic cell hybrid libraries by selective recombination with the plasmid vector, piVX, containing a human Alu repetitive sequence (Neve et al., 1983).

Anonymous DNA probes containing both single-copy and repetitive DNA

have been used directly against genomic blots, to identify RFLPs, by using either high stringency hybridization conditions (Fisher et al., 1984) or by 'blocking-out' the repetitive DNA in the clone with an excess of unlabelled human genomic DNA (Barker et al., 1985; Sealey et al., 1985).

1.4.5 OPTIMIZING THE SEARCH FOR RFLPS

The probability that an RFLP will be found by an anonymous DNA probe depends on five factors (Hofker et al., 1986; Skolnick and White, 1982):-

- (1) The type of probe (cDNA or genomic).
- (2) The size (kb) of the probe.
- (3) The number and nature of the individuals used in the screening panel.
- (4) The number and type of restriction enzymes.
- (5) The type of chromosome (autosome or the X).

Feder et al. (1985) found that using large size (10-20 kb) genomic DNA probes to screen six random individuals restricted with enzymes such as MspI and TaqI was efficient in the detection of RFLPs. cDNA clones were found to be less polymorphic than clones derived from genomic libraries (Helentjaris and Gesteland, 1983).

In a recent extensive study to identify RFLP loci, Schumm et al. (1988) found that of 1,664 single-copy probes from a λ Charon 4A genomic library, 515 (30%) revealed polymorphisms against a panel of DNAs from five unrelated individuals digested with eight restriction enzymes. The restriction enzymes MspI, TaqI and RsaI were the most efficient in the detection of RFLPs.

Using four to nine random individuals in the screening rationale

would miss a large proportion of rare variants (frequency of rare allele between 0.001-0.02), a few marginal RFLPs (0.05-0.15) but would capture the majority of the useful RFLPs (0.20-0.30) (Skolnick and White, 1982).

A model for estimating the relative efficiency with which restriction enzymes can be used to detect RFLPs, based on observed frequencies of dinucleotides in the human genome, has been developed (Wijsman, 1984). Based on the model, enzymes such as MspI and TaqI would have a higher than average frequency in the detection of RFLPs, a result confirmed by Barker et al. (1984a). The greater frequency of polymorphisms detected by MspI and TaqI was thought to be related to the CpG dinucleotide in their recognition sequence, since the C nucleotide is often methylated and has a high tendency for C->T transition mutation (Barker et al., 1984a).

Of the 611 reported RFLPs in HGM8 (1985), including probes detecting multiple RFLPs, 212 (34.7%) were detected by MspI and TaqI. The restriction endonucleases, BglIII, EcoRI, HindIII, MspI, PstI, PvuII, RsaI and TaqI collectively detected 70 percent of the reported RFLPs (HGM8, 1985).

Hofker et al. (1986) found that the probability of a DNA probe detecting RFLPs appeared to be influenced by the origin of the probe - autosomal derived DNA probes showed a higher level of polymorphism than DNA probes derived from the X chromosome. This implied that the X chromosome showed less genetic variation at restriction sites than the autosomes, a result that was in agreement with the findings of Donis-Keller et al. (1987).

1.4.6 USE OF RFLPS FOR GENETIC ANALYSES

RFLPs were first used for the linkage of temperature-sensitive

mutations of adenovirus to specific restriction fragment differences (Grodzicker et al., 1974). RFLPs have been used to demonstrate the maternal inheritance of mammalian mitochondrial DNA (Hutchinson et al., 1974) and for the genetic analysis of chromosomal markers in yeast (Petes and Botstein, 1977).

RFLPs have been detected in human genomic DNA using either gene-specific probes, cDNAs or with anonymous DNAs (Pearson et al., 1987). Jeffreys (1979) reported a heterozygosity for a PstI restriction site within the intervening sequence of the human δ -globin gene when screening 60 unrelated individuals with a β -globin gene probe. RFLPs were also detected in the γ -globin gene regions (Jeffreys, 1979; Tuan et al., 1979).

A HpaI RFLP present 5.0 kb from the 3' end of the β -globin gene was found to be associated with the sickle haemoglobin mutation (Kan and Dozy, 1978a) and has been used to diagnose the sickle cell trait in utero (Kan and Dozy, 1978b). Gene-specific probes for other single-gene inherited disorders have been cloned and many identify RFLPs that are useful for prenatal diagnosis (Cooper and Schmidtke, 1986, 1987). The list includes Lesch-Nyhan syndrome (Nussbaum et al., 1983a), phenylketonuria (Woo et al., 1983) and the thalassaemias (Orkin et al., 1978).

In these cases the RFLPs were recognized by their relationship to the gene of interest and would not have been detected without the prior cloning of the gene (Cooper and Schmidtke, 1986, 1987). The direct analysis of genetic diseases was only possible if gene-specific probes could be isolated (reviewed in Lowe, 1986). However, the majority of genetic diseases are only known by their phenotype and are not at present readily amenable to cloning (Cooper and Schmidtke, 1986; McKusick, 1986).

The first RFLP in an anonymous DNA clone detected at least eight

alleles (Wyman and White, 1980). There are now well over 1,000 polymorphic DNA markers, the majority being anonymous DNAs detecting two alleles (Pearson et al., 1987; Schumm et al., 1988).

RFLPs detected by anonymous DNAs can be applied to the analysis of a genetic disease even if the biochemical mechanism responsible for the dysfunction has not been elucidated (reviewed in Gusella, 1986).

Pedigrees in which inherited traits are known to be segregating can be analyzed for the co-inheritance of the RFLP(s) and the disease gene by linkage analysis (Ott, 1986, see Chapter 6).

Knowledge of the chromosomal location of the linked RFLP(s) permits the inferred assignment of the disease gene to the same region. This allows the mapping of gene responsible for the trait with respect to the RFLP(s) without requiring the gene's DNA (Gusella, 1986). Anonymous DNA probes have been assigned to various human chromosomes by hybridization to genomic DNA from panels of human-rodent somatic cell hybrid lines (Gusella et al., 1980; Kao et al., 1982), by in situ hybridization of labelled probe directly to metaphase chromosomes (Harper and Saunders, 1981) or by linkage analysis (Donis-Keller et al., 1987).

The first autosomal disease to be linked to an anonymous DNA marker was Huntington's disease (Gusella et al., 1983). Duchenne muscular dystrophy (DMD) was the first X-linked disorder to be linked to an anonymous DNA marker (Murray et al., 1982). The chromosomal locations for the loci responsible for polycystic kidney disease (PKD1) (Reeders et al., 1985), familial Alzheimer's disease (St George-Hyslop et al., 1987) and cystic fibrosis (Knowlton et al., 1985; Wainwright et al., 1985; White et al., 1985b) as well as many others (Pearson et al., 1987) have been identified by testing random DNA markers for linkage in families segregating these disorders. Linked RFLPs to disease loci are being utilized for prenatal diagnosis (Gusella, 1986).

The potential problem associated with the use of linked RFLPs in prenatal diagnosis, is that recombination between the disease locus and the RFLP can occur during meiosis after which the mutant gene becomes associated with a different marker allele (Gusella, 1986). The closer the linkage between the RFLP and the gene, the less likely will be the occurrence of a recombination event between them. The accuracy of diagnosis can be improved by defining RFLPs closer to, or within, the disease locus (Darras et al., 1987; Wiggs et al., 1988) or by using a second RFLP on the other side of the locus (Breuning et al., 1987).

An anonymous DNA probe may often detect multiple two allele RFLPs (Barker et al., 1984b; Litt et al., 1986). The information from each independent RFLP, from a given locus, can be combined to construct haplotypes and each can be used as an allele for the locus. The result is that the PIC value increases, hence making the marker potentially more informative (Barker et al., 1984b; Litt et al., 1986). An anonymous DNA probe known to be linked to a specific disease gene, or a locus of interest, can be used to screen a genomic library to obtain further nearby RFLPs thereby allowing maximum information to be gained from a set of pedigrees (Scheffer et al., 1986).

RFLPs detected by anonymous DNAs have been used in cancer research (Wainscoat and Thein, 1985), for the analysis of polygenic disorders such as diabetes mellitus (Rotwein et al., 1983) and coronary artery disease (Rees et al., 1983) and for the study of evolutionary relationships of human populations (Wainscoat et al., 1986).

A total of 2,667 genes and anonymous DNAs have been cloned, of which 1,193 of these are polymorphic (Pearson et al., 1987). Over 200 RFLPs, have PIC values ranging from 0.5-0.99 (Pearson et al., 1987).

1.4.7 CONSTRUCTION OF A HUMAN GENOME RFLP LINKAGE MAP

Botstein et al. (1980) devised a strategy for the construction of a human genome linkage map based on approximately 150 evenly spaced RFLPs, preferably having many alleles and PIC values close to 1.0, each 20 cM (or the equivalent of 20,000 kb of double stranded DNA, Renwick, 1969) apart. The number of required RFLPs was based on Renwick's sex-averaged map length of 3,300 cM for the autosomal portion of the human genome (Renwick, 1971) and that 20 cM was the maximum distance desired between RFLP marker loci that would still allow linkage to be detected. Lange and Boehnke (1982) have indicated that, since RFLPs occur randomly over the genome, tight clusters and sizable gaps in the genome would appear, hence requiring the isolation of a much larger number of RFLPs than Botstein et al. (1980) originally proposed.

Detailed RFLP linkage maps have been constructed for chromosomes 7 (Donis-Keller et al., 1986), 12 (White et al., 1986) and the X (Drayna et al., 1984), as well as for several chromosomal regions such as 6p (Leach et al., 1986) and 13q (Leppert et al., 1986).

Donis-Keller et al. (1987) have constructed a linkage map of the entire human genome, based on the pattern of inheritance of 403 polymorphic loci, including 393 RFLPs, in a panel of DNAs from 21 three generation families. The loci were arranged into linkage groups representing the 23 human chromosomes. The linkage map was detectably linked to at least 95 percent of the DNA in the genome. The average spacing of each RFLP was approximately 10 cM. Many intervals were considerably larger and some regions were poorly covered with RFLPs, a finding that supported the studies of Lange and Boehnke (1982).

The availability of the linkage map of the human genome, for the purpose of studying genetic diseases, allows:-

- (1) The chromosomal location of newly discovered linkages between RFLPs and previously unmapped disease loci would be known since the entire genome is scanned.
- (2) Several nearby starting points would be available for efforts to eventually clone the disease gene or any loci of interest (1.4.8).
- (3) Prenatal or presymptomatic diagnosis would become more accurate through the use of markers that flank the disease gene.

The use of a RFLP linkage map is a much more efficient and systematic approach to gene mapping than a trial-and-error approach with randomly chosen RFLPs (Botstein *et al.*, 1980).

1.4.8 METHODS TO CLONE DISEASE LOCI MAPPED BY LINKED RFLPS

The knowledge of the chromosomal region of a disease gene, or locus of interest, such as a fragile site (1.5) provides a path to be able to eventually clone the locus. Approaches being tested include:-

- (1) Direct microdissection and microcloning of the relevant region from a number of human chromosomes (Bates *et al.*, 1986). This technique was used to isolate DNA clones near the vicinity of the cystic fibrosis locus (Kaiser *et al.*, 1987).
- (2) Identification of expressed sequences in the region of interest from cDNA libraries from appropriate tissues. This approach was used to isolate the gene responsible for chronic granulomatous disease (Royer-Pokora *et al.*, 1986).
- (3) The use of natural chromosomal rearrangements in the region of interest. This approach was used to clone DNA fragments derived from the DMD gene (Kunkel *et al.*, 1985).
- (4) Production of restriction fragments of very large chromosomal

fragments using orthogonal field gel electrophoresis (Gemmill et al., 1987; Schwartz and Cantor, 1984) or field inversion electrophoresis (Carle et al., 1986).

- (5) Development of methods to 'jump', 'hop' or 'skip' along chromosomes over distances of hundreds of kilobases using jumping (Collins et al., 1987; Poustka et al., 1987) and linking libraries (Poustka and Lehrach, 1986) as well as special cloning vectors (Collins and Weissman, 1984).

1.4.9 **HYPERVARIABLE REGIONS IN THE HUMAN GENOME**

A HVR (or VNTR) consists of tandem repeats of a short DNA sequence and the variability in the fragment length is due to the difference in the number of copies of the tandem repeat sequence contained between a set of identical restriction sites.

The first HVR was reported by Wyman and White (1980) and had at least eight alleles. HVRs have been reported at many other genomic loci (Bell et al., 1982; Boylan et al., 1987; Capon et al., 1983; Goodbourn et al., 1983; Higgs et al., 1981; Knott et al., 1986; Stoker et al., 1985; Wiggs et al., 1988). HVRs differ substantially in their variability, ranging from six different alleles (Sykes et al., 1985) to more than 80 (Balazs et al., 1986).

The high number of different possible alleles, and the high degree of heterozygosity, gives HVRs the potential to be informative in almost all families for linkage analysis studies of genetic disorders (White et al., 1985a). Biallelic RFLPs are uninformative whenever critical individuals are homozygous for a particular allele. Since many of the HVRs have a high number of alleles this is less likely to occur.

HVRs have been used to map disease loci of unknown chromosomal origin (Gusella, 1986). The 3'HVR from the $\alpha 1$ -globin gene on chromo-

some 16 (Higgs et al., 1981) was shown to co-segregate and have tight linkage to PKD1 (Reeders et al., 1985). This probe was used for the prenatal diagnosis of PKD1 (Reeders et al., 1986).

Another class of probe, detecting multiple HVRs, was isolated by Jeffreys et al. (1985a). The DNA probes contained a 33 bp repeat (minisatellite) found in the intron of the myoglobin gene (Weller et al., 1984). One clone detected multiple DNA fragments in human DNAs and produced individual-specific DNA 'fingerprints' characteristic of each DNA sample (Jeffreys et al., 1985b). The multiple DNA fragments were inherited in a Mendelian fashion, their heterozygosity was almost 100 percent and the majority of the bands were not linked to one another (Wong et al., 1987). The minisatellite probes have been used for the linkage analysis of genetic disorders, such as neurofibromatosis and the haemoglobinopathies (Jeffreys et al., 1986).

One of the restriction fragments detected by a minisatellite probe, was cloned and found to hybridize to a single genomic locus (Wong et al., 1986). The locus was extremely polymorphic, having at least 77 alleles and a heterozygosity of 97 percent. Cloned minisatellites should provide a panel of extremely informative locus specific probes that are ideally suited for linkage analyses (Wong et al., 1986).

Nakamura et al. (1987a) have identified a human genomic locus, that consisted of a large (250-500 kb) HVR clustered at a single locus and was highly polymorphic. The midisatellite consisted of a simple repeating unit that varied from 37-43 bp and had some homology to various minisatellite DNAs (Jeffreys et al., 1985a).

Nakamura et al. (1987b) constructed synthetic oligomeric sequences derived from the tandem repeats of the myoglobin gene, zeta-globin pseudo gene, insulin gene and the X-gene region of hepatitis B virus as probes of various human genomic cosmid libraries. Of 372 cosmid DNAs

tested, 77 (21%) detected VNTRs, with nearly 90 percent having three or more alleles. HVRs have also been detected in randomly selected cosmid clones (Buroker et al., 1987a, 1987b).

Jeffreys et al. (1985a) have suggested that the VNTR sequences might encode 'hotspots' for recombinational activity. The chi sequence of λ , 5' GCTGGTGG 3', implicated as a hotspot for *recA*-mediated recombination in E.coli (Smith et al., 1981) was similar to some of the core sequences of the minisatellites (Jeffreys et al., 1985a) and VNTRs (Nakamura et al., 1987a).

Oligonucleotide probes specific for simple tandem repeats of four bps have been used to detect HVRs (Ali et al., 1986). Insert free, wild-type M13 bacteriophage detects minisatellites in the human genome (Vassart et al., 1987) with different patterns from those obtained with the minisatellite probes of Jeffreys et al. (1985a).

Preliminary findings have shown that HVR sequences are found mainly at the ends of the chromosomes (Donis-Keller et al., 1987; Royle et al., 1987) hence their usefulness may be restricted to the mapping of loci to these regions.

1.4.10 SUMMARY

Genetic polymorphisms provide a way to distinguish between two or more alleles of specific loci in the genome. They can be used as specific 'markers' for various genetical analyses such as the mapping of gene loci of which little is known regarding their biochemical basis.

Genetic polymorphisms have been detected in blood group substances, enzymes, serum proteins and in genomic DNA. Few of the protein polymorphic markers are useful enough for genetic linkage studies because of their low PIC values. Furthermore, the human genome is scantily covered in polymorphic protein markers, making the mapping and eventual

isolation of disease loci difficult to achieve.

The use of such markers are becoming redundant following the discovery of genomic DNA sequence polymorphisms (RFLPs, VNTRs, mini and midisatellites) which are highly suited for the mapping of such loci. The human genome contains an enormous amount of DNA sequence variation and recombinant DNA technology, combined with classical linkage analysis methods, has provided the means to access and exploit this new source of variability.

A linkage map of the entire human genome has been constructed and was detectably linked to at least 95 percent of the DNA in the genome.

The use of RFLPs, in conjunction with new pulsed-field gel electrophoretic and cloning methods, provide avenues in which mapped loci could be cloned and sequenced for analysis.

The high number of alleles at HVR loci potentially makes them more informative in almost all families for linkage studies of genetic disorders than biallelic RFLPs.

The use of RFLPs is ideally suited for the investigation of human chromosome 16 and the fragile sites (1.5) found on this chromosome.

1.5 FRAGILE SITES IN THE HUMAN GENOME

1.5.1 DEFINITION OF A FRAGILE SITE

Fragile sites on human chromosomes (Fig. 1.1) were defined by Sutherland (1979) as specific non-staining points in the genome which displayed the following features:-

- (1) A tendency to form chromosome and chromatid gaps of variable width.
- (2) Are always at the same chromosomal locus when examined in the cells of a specific patient or kindred.
- (3) Are inherited in a Mendelian co-dominant fashion.

FIGURE 1.1

EXAMPLES OF FRAGILE SITES IN THE HUMAN GENOME

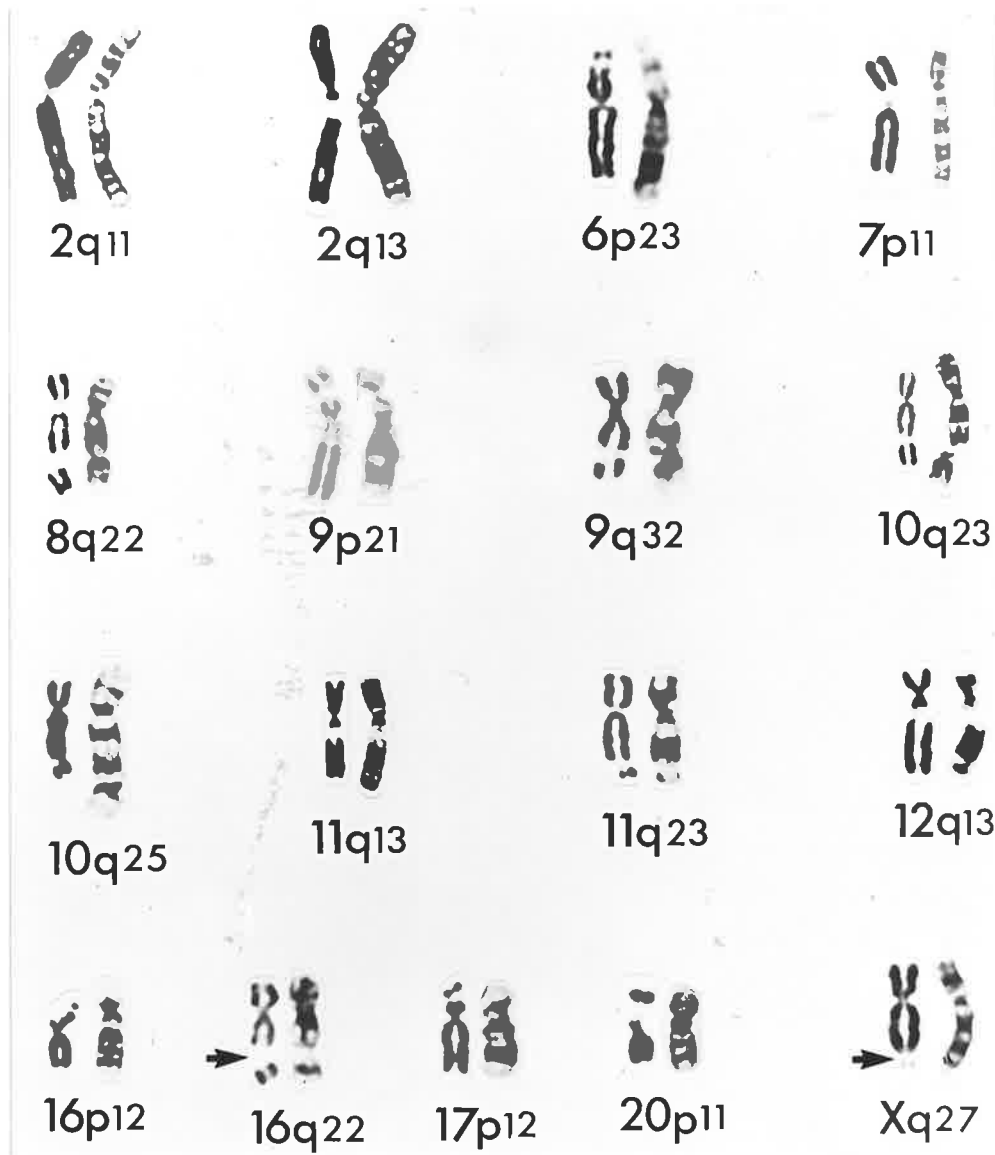

The fragile sites, visualized as a non-staining gap usually in both chromatid arms (left hand side of each metaphase chromosome pair), are shown in respect to the corresponding G banded homologue. As examples, the location of the fragile sites at 16q22 (FRA16B) and Xq27 (FRAXA) are indicated by an arrow.

(Photo kindly provided by Dr. G.R. Sutherland)

(4) Result in abnormal chromosomes such as deletions, triradial (or multiradial) figures and acentric fragments by breakage at the fragile site under appropriate tissue culture conditions.

1.5.2 DISCOVERY OF FRAGILE SITES

Dekaban (1965) described the first chromosomal lesion that was a fragile site and Lejeune *et al.* (1968) were the first to demonstrate the heritable nature of a fragile site. The fragile site near the terminus of the long arm of the X chromosome (the fragile X) was shown to be associated with a form of X-linked mental retardation (Lubs, 1969) and is now the most common cause of inherited mental retardation (Sutherland, 1985). The fragile X was sublocalized to band Xq27.3 using scanning electron microscopy (SEM) analysis (Harrison *et al.*, 1983) and high-resolution chromosome preparations (Krawczun *et al.*, 1985). Linkage of the fragile X to glucose-6-phosphate-dehydrogenase (G6PD) (Filippi *et al.*, 1983) and the Factor IX locus (Camerino *et al.*, 1983) suggested that the genetic locus of the fragile X syndrome was at or very near the fragile X site.

It took seven years for the association of the fragile X and mental retardation to be confirmed (Giraud *et al.*, 1976; Harvey *et al.*, 1977). This was due to the use of tissue culture conditions that suppressed the expression of the fragile site (Sutherland, 1983). There are now a number of tissue culture conditions which allow the detection of a variety of different fragile sites (Sutherland and Hecht, 1985; Sutherland and Mattei, 1987).

Since Dekaban's (1965) initial observation, there have been 104 other fragile sites (including three unclassified types) of varying groups and types (Sutherland and Mattei, 1987; Takahashi *et al.*, 1988). Only the fragile X (FRAXA) has been shown to be associated with a

disease state, mental retardation, and as a result has been the one mostly investigated (reviewed in Nussbaum and Ledbetter, 1986).

Some of the other fragile sites have been implicated in the chromosomal rearrangements seen in malignant cells, since these sites have been found to be statistically significantly coincident with specific cancer breakpoints (De Braekeleer *et al.*, 1985; Hecht and Sutherland, 1984; LeBeau and Rowley, 1984; Miro *et al.*, 1987; Tedeschi *et al.*, 1987; Yunis and Soreng, 1984).

Recent studies suggest that the association was most probably circumstantial (Porfirio *et al.*, 1987; Sutherland, 1988; Sutherland and Simmers, 1988). Furthermore, the following fragile sites do not coincide with the breakpoints at or near 16q22 (FRA16B and FRA16C) in acute myelomonocytic leukemia (Simmers *et al.*, 1987a), 11q23 (FRA11B) in Ewing sarcoma (Simmers and Sutherland, 1988) and at 11q13.3 (FRA11A) in B-cell lymphocytic leukemia (Puspurs *et al.*, 1988).

1.5.3 FEATURES OF FRAGILE SITES

Fragile sites are not usually present in metaphase chromosome preparations but must be induced by exposing cells, usually lymphocytes, to appropriate tissue culture conditions prior to harvesting them for cytogenetic analyses (Sutherland, 1977; Sutherland and Mattei, 1987). The specific tissue culture conditions required to induce the various fragile sites (Table 1.1) implies that different biochemical mechanisms are involved in their expression (Glover, 1985).

The fragile sites are seen in only a percentage of cells, usually less than 50 percent (Sutherland, 1983), despite every cell of a fragile site carrier having the capacity to express the fragile site (Giraud *et al.*, 1976).

Fragile sites show a broad range of frequencies in the general

TABLE 1.1

FRAGILE SITE CLASSIFICATION

TYPE	CLASS	HGM7 ^a	HGM9 ^b	FREQUENCY	EXAMPLE	REFERENCE
Folate sensitive	rare	14	18	~1/500 ^c	<u>FRAXA</u>	Sutherland (1983).
BrdU inducible	rare	1	2	~1/40	<u>FRA10B</u>	Sutherland <i>et al.</i> (1984).
Distamycin A inducible	rare	2	3	~1/20 ^d	<u>FRA16B</u>	Schmid <i>et al.</i> (1986).
Aphidicolin inducible	common	3	68	e	<u>FRA3B</u>	Glover <i>et al.</i> (1984).
5-azaC inducible	common	-	3	e	<u>FRA1H</u>	Sutherland <i>et al.</i> (1985b).
BrdU inducible	common	-	7	e	<u>FRA13B</u>	Sutherland <i>et al.</i> (1985b).

^aValues obtained from HGM7 (1984).

^bValues obtained from Sutherland and Mattei (1987) and including the recently identified distamycin A inducible fragile site at 8q24.1 (Takahashi *et al.*, 1988).

^cApproximate frequency for the group.

^dFRA16B, in the German population, induced with berenil (Schmid *et al.*, 1986).

^eMay be present in all individuals.

population, from rare to very common (Table 1.1) (Sutherland and Mattei, 1987). For example, only one ascertainment had been documented for the fragile site at 6p23 (FRA6A) (Sutherland *et al.*, 1983) whereas the fragile site at 3p14 (FRA3B) was present in every individual examined (Smeets *et al.*, 1986).

Fragile sites have been utilized as markers for linkage analysis studies in families with the fragile sites (Mulley *et al.*, 1983a, 1983b; Mulley, 1985b; Sutherland *et al.*, 1982). The alpha-haptoglobin locus was mapped to the long arm of chromosome 16 by linkage analysis with the fragile site at 16q22 (FRA16B) (Magenis *et al.*, 1970). The genetic distance between these loci was calculated to be approximately 9 cM (Mulley, 1985b). The genetic length between two fragile sites (FRA10A and FRA10B) on the long arm of chromosome 10 was estimated to be 11 cM in females (Sutherland *et al.*, 1982). The value was in good agreement with conventional methods in calculating genetic distances between loci (Mulley, 1985b). The HLA region was localized to 6p23 by linkage analysis of a family with the fragile site at 6p23 (FRA6A) (Mulley *et al.*, 1983a). The results of Sutherland *et al.* (1982) and Mulley *et al.* (1983a) suggest that fragile sites do not disrupt recombination frequencies, hence making them valid markers for linkage analysis. Furthermore, the DNA responsible for the fragile site is most likely at the site of expression. These findings suggested that it was possible, using recombinant DNA technology, to obtain closely linked RFLP markers (1.4.6) to the 'fragile site' DNA. Furthermore, it was also possible to eventually clone the fragile site DNA since the 'information' required to express the fragile site was at or very close to the fragile site. At present, no fragile site has been cloned although a large number of groups are attempting to clone the clinically important fragile X (Nussbaum and Ledbetter, 1986).

Human metaphase chromosomes expressing fragile sites have been used for in situ hybridizations for the localization of genes (Fratini et al., 1986; Mattei et al., 1985; Purrello et al., 1985; Simmers et al., 1986; Szabo et al., 1984) and anonymous DNAs (Callen et al., 1988a, 1988b) with respect to the site.

Little is known regarding the chromatin structure at a fragile site (Nussbaum and Ledbetter, 1986; Sutherland, 1985). Harrison et al. (1983) used SEM to examine the fragile site at Xq27.3. The studies revealed a prominent isochromatid gap with the distal chromosome fragments well separated from the proximal long arm. The fragments usually remained attached to the main part of the chromosome by individual fibers of chromatin. The appearance was similar to decondensed chromatin seen in incompletely replicated regions of S-phase prematurely condensed chromosomes (Gollin et al., 1985a).

A fragile site may represent incompletely replicated DNA, or damaged DNA that is undergoing repair, forced into mitosis before proper chromatin packaging has occurred (reviewed in Sutherland and Hecht, 1985). Only by cloning and sequencing the DNA at a fragile site can this and other uncertainties be unravelled.

1.5.4 CLASSIFICATION OF FRAGILE SITES

Fragile sites are classified into five specific types (folate sensitive, distamycin A inducible, 5-bromodeoxyuridine (BrdU) requiring, 5-azacytidine (5-azaC) inducible and aphidicolin inducible) according to the tissue culture conditions under which they are induced, and further classified into two classes, rare (or heritable) and common (or constitutive) depending on their frequency in the population (Table 1.1) (Sutherland and Mattei, 1987). In addition, Table 1.1 shows the number of the various fragile sites reported at the commencement (HGM7,

1984) and at the completion of this study (Sutherland and Mattei, 1987).

The nomenclature to identify the various fragile sites, uses the triplet FRA, followed by the chromosome number and a letter (Berger et al., 1985). For example, FRA16B, refers to the distamycin A inducible fragile site on the long arm of chromosome 16 at band position 22.1 (ISCN, 1985). There are two types of fragile site nomenclature: gene and cytogenetic (Sutherland and Mattei, 1987).

1.5.5 THE RARE FRAGILE SITES

There are three types of fragile sites (folate sensitive, BrdU inducible and distamycin A inducible) that have been classified as rare due to their low frequencies in the general population (Table 1.1).

1.5.5.1 THE FOLATE SENSITIVE FRAGILE SITES

The folate sensitive fragile sites, of which 18 (including the fragile X) have been identified (Table 1.2) (Sutherland and Mattei, 1987), are expressed in tissue culture medium deficient in folic acid and thymidine (Sutherland, 1979). Deprivation of folic acid and thymidine (thymidylate stress) during the last few hours of culture time was required for induction, indicating that expression was determined either late in S or early in G₂ phase (Sutherland, 1979). The fragile sites can also be induced in medium containing inhibitors of dihydrofolate reductase, such as methotrexate (MTX) (Sutherland, 1979), or by inhibitors of thymidylate synthetase, such as FUdR (5-fluoro-2'-deoxyuridine) (Glover, 1981; Tommerup et al., 1981) or FCdR (5-fluoro-2'-deoxycytidine) (Jacky and Sutherland, 1983).

Glover (1981) showed that folate sensitive fragile sites could be induced by FUdR in the presence of normally inhibiting concentrations of folic acid but not in the presence of thymidine. Somatic hybrid

TABLE 1.2

THE RARE FOLATE SENSITIVE FRAGILE SITES^a

GENE SYMBOL	REGIONAL ASSIGNMENT	STATUS ^b
<u>FRA2A</u>	2q11.2	C
<u>FRA2B</u>	2q13	C
<u>FRA2K</u>	2q22.3	P
<u>FRA6A</u>	6p23	P
<u>FRA7A</u>	7p11.2	C
<u>FRA8A</u>	8q22.3	C
<u>FRA9A</u>	9p21.1	C
<u>FRA9B</u>	9q32	C
<u>FRA10A</u>	10q24.2 ^c	C
<u>FRA11A</u>	11q13.3	C
<u>FRA11B</u>	11q23.3	C
<u>FRA12A</u>	12q13.1	C
<u>FRA12D</u>	12q24.13	P
<u>FRA16A</u>	16p13.11 ^d	C
<u>FRA19B</u>	19p13	C
<u>FRA20A</u>	20p11.23	C
<u>FRA22A</u>	22q13	C
<u>FRAXA</u>	Xq27.3	C

^aFrom Sutherland and Mattei (1987).

^bConfirmed or Provisional assignment.

^cPreviously localized to 10q23.3 (Berger *et al.* 1985).

^dReassigned from 16p12.3 (Callen *et al.* 1988b).

cells made with a fragile X chromosome in a rodent cell deficient in thymidylate synthetase demonstrated the fragile site when deprived of exogenous thymidine (Nussbaum et al., 1985). This implied that a deficiency of thymidine-5'-monophosphate (dTMP) in the cell, due to thymidylate stress, was the cause of expression of the fragile sites (Glover, 1981; Sutherland, 1979). Sutherland (1979) proposed that folate sensitive fragile sites were composed of sections of thymidine-rich DNA that do not fully complete DNA synthesis, hence leaving gaps, when the thymidine-5'-triphosphate (dTTP) nucleotide pool was depleted.

Depletion of dTTP results in the incorporation of uracil into DNA (Grafstrom et al., 1978). The incorporated uracil is removed by uracil-N-glycosylases and excision-repair enzymes repair the vacant sites (Sekiguchi et al., 1976). It has been suggested that inadequate removal of uracil from DNA, in the presence of limiting dTTP levels, induces the fragile site (Krumdieck and Howard-Peebles, 1983).

Under conditions of limiting dTTP, the amount of uracil incorporated into the DNA is ~1 uracil base per 10^6 nucleotides (Goulian et al., 1980). Such a low level of uracil incorporation was considered not to have any significant effect on chromatin structure, but the repetitive incorporation and removal of uracil causing incomplete repair to occur before mitosis was most likely the reason for the expression (Hagerman, 1984). In addition, the enzymes that prevent the accumulation of uracil into DNA were not deficient in fragile X cells (Wang et al., 1985a).

Sutherland et al. (1985a) found that high concentrations of thymidine induced the expression of folate sensitive fragile sites whereas high concentrations of BrdU, an analogue of thymidine, did not. High levels of thymidine have been used for the induction of fragile sites in fibroblasts (Sutherland and Baker, 1986a) and for prenatal diagnosis of the fragile X (Sutherland et al., 1987b).

The addition of deoxycytidine triphosphate (dCTP) after induction with high concentrations of thymidine inhibited the expression (Sutherland et al., 1985a). Thus, depletion of either thymidine triphosphate (dTTP) or dCTP for DNA synthesis induced the expression of folate sensitive fragile sites. From this data, a model for the possible DNA sequence at a folate sensitive fragile site was proposed (Sutherland et al., 1985a). Sutherland and Baker (1986b) showed that 2'-deoxyguanosine monophosphate (dGMP) weakly induced the expression of folate sensitive fragile sites whereas adenosine-5'-triphosphate (ATP) and cytidine-5'-triphosphate (CTP) did not.

Aphidicolin, a specific inhibitor of DNA polymerase α (Collins et al., 1984), weakly induced the fragile X and, when combined with thymidylate stress, the expression was decreased (Glover et al., 1984). Caffeine, an inhibitor of DNA repair mechanisms (Roberts, 1984), enhanced the expression of the fragile X in hybrid cells (Ledbetter et al., 1986a) but not in lymphocyte cultures (Abruzzo et al., 1986) indicating that the hybrid cell system was more sensitive for the induction of the fragile X.

Both 5-azaC and S-adenosylhomocysteine (SAM), which are inhibitors of methyl transferases, were shown to inhibit the expression of the fragile X in a human lymphoblastoid cell line grown in the presence of FUdR, suggesting that DNA methylation may be involved in the expression of the fragile X (Mixon and Dev, 1983). These findings were in direct contrast to Glover et al. (1986) who found that DNA methylation had no effect on fragile X expression.

Howard-Peebles and Pryor (1981) demonstrated that methionine, a methyl group donor, was required for fragile X expression whereas Abruzzo et al. (1985) reported finding no consistent effects of excess methionine on fragile X expression. It is now regarded that neither DNA

methylation nor the inclusion of methionine in the tissue culture medium are directly responsible per se for fragile X expression (Nussbaum and Ledbetter, 1986).

Erbe and Wang (1982) demonstrated normal thymidylate synthetase activity in fragile X lymphoblasts and failed to find any other defects in folate metabolism (Wang and Erbe, 1985b). Popovich et al. (1983) found no significant differences in the total folate content or in the distribution of folate cofactors between fibroblasts from patients with and without the fragile X, both before and after thymidylate stress.

The findings of Erbe and Wang (1982), Popovich et al. (1983) and Wang and Erbe (1985b) suggested that there were no biochemical differences, at the folate metabolism level, between normal and fragile X cells to explain the cause of the fragile site.

The fragile X was expressed in somatic cell hybrids (Nussbaum et al., 1983b; Warren and Davidson, 1984) implying that the rodent genome could not 'correct' the fragile X and that human autosomal loci were not necessary for expression. A somatic cell hybrid containing the Xq24->qter segment from a fragile X was able to express the fragile site, implying that the short arm and the proximal long arm of the X chromosome were not necessary for expression (Nussbaum et al., 1986a).

Ledbetter et al. (1986b) studied the expression of the fragile X in somatic cell hybrids constructed from normal transmitting fragile X males (implied from pedigree analysis, but fail to exhibit the fragile site in lymphocytes), fragile X males and normal non-fragile X males. Following caffeine treatment, the hybrids from normal males expressed the fragile X at low frequencies (4-5%), followed by transmitting males (12%) and those of the fragile X males (30-43%). Ledbetter et al. (1986b) concluded that non-fragile X males had a common fragile site at Xq27.3 which fully mutates to a rare heritable fragile X.

Recent studies have indicated that the common fragile site reported by Ledbetter et al. (1986b) was not at Xq27.3 but at Xq27.2 (Sutherland, personal communication), hence the two fragile sites are not coincident. Nevertheless, the findings of Ledbetter et al. (1986b) are consistent with the hypothesis that expression of the folate sensitive fragile sites are due to fundamental differences in the DNA sequence at the fragile site (Nussbaum et al., 1986b; Sutherland et al., 1985a; Sutherland and Baker, 1986b).

Wenger et al. (1987) reported an increase in sister chromatid exchange at the fragile X in affected males, suggesting that breakage occurred at the fragile site. Warren et al. (1987) demonstrated, with the use of somatic cell hybrids containing the fragile X site and flanking RFLP markers, that breakage occurred at or very near the site.

No homozygote for an autosomal folate sensitive fragile site has been reported, hence it is not known if homozygosity at the fragile site locus would be deleterious (Sutherland and Hecht, 1985).

Folate sensitive fragile sites have been found in the genomes of the Persian vole Ellobius lutescens Th. (Djalali et al., 1985) and the mouse (Djalali et al., 1987; Hunt and Burgoyne, 1987). Hunt and Burgoyne (1987) failed to find a correlation between mouse fragile sites and specific chromosomal breakpoints involved in mouse tumours, giving further credence to the suggestion that fragile sites are not associated with cancer breakpoints (Sutherland and Simmers, 1988).

RFLPs detected by anonymous DNAs and cloned genes have been used for linkage analysis studies with the fragile X (Camerino et al., 1983; Hofker et al., 1987a; Holden et al., 1984; Mulley et al., 1987; Mulligan et al., 1985; Oberle et al., 1986; Patterson et al., 1987; Veenema et al., 1987) as well as for carrier detection and prenatal diagnosis (Oberle et al., 1985; Mulley et al., 1987; Tommerup et al., 1985).

1.5.5.2 THE BRDU INDUCED FRAGILE SITE

FRA10B, the only fragile site in this group, is induced by BrdU (Scheres and Hustinx, 1980; Sutherland *et al.*, 1980), 5-bromo-deoxycytidine (BrdC) (Sutherland *et al.*, 1984), FUdR and 5-iodo-2'-deoxyuridine (IdU) (Gollin *et al.*, 1985b). FRA10B is rarely expressed spontaneously in lymphocyte cultures (Gollin *et al.*, 1985a; Taylor and Bunday, 1983) and homozygous individuals have been identified (Sutherland, 1981). FRA10B was found to be present in ~1/40 individuals in the Australian Caucasian population (Sutherland, 1982).

The level of BrdU incorporated into the DNA 8-9 hours before mitosis, rather than the concentration in the cell, was the critical factor governing the expression of FRA10B (Gollin *et al.*, 1985b; Sutherland *et al.*, 1980). Sutherland *et al.* (1980) showed that breakage occurred at or very close to the fragile site by observing sister chromatid exchanges at that region.

Gollin *et al.* (1985b), based on the induction with FUdR, have suggested that FRA10B is a region of DNA that has failed to complete DNA synthesis. FUdR inhibits thymidylate synthetase and leads to thymidylate stress in the cell, a prerequisite for the expression of folate sensitive fragile sites (Sutherland, 1979). FRA10B could not be induced in folic acid and thymidine free medium or by the addition of MTX, in the absence of BrdU (Sutherland *et al.*, 1980).

A BrdU sensitive fragile site has been found in the genome of the Chinese hamster (Hsu and Somers, 1961) as well as in the cactus mouse, Peromyscus eremicus (Schneider *et al.*, 1980).

1.5.5.3 THE DISTAMYCIN A INDUCIBLE FRAGILE SITES

This group, all of which are induced with the oligopeptide antibiotic distamycin A (Zimmer, 1975), contains the fragile site FRA16B

(Schmid et al., 1980), FRA17A (Sutherland et al., 1984) and the one recently found in the Japanese population at 8q24.1 (Takahashi et al., 1988). FRA16B can also occur spontaneously (Magenis et al., 1970), without the inclusion of distamycin A in the lymphocyte culture (Schmid et al., 1984).

FRA16B and FRA17A have been induced with BrdU (Croci, 1983; Sutherland et al., 1984), Hoechst 33258, netropsin (Schmid et al., 1980, 1984; Sutherland et al., 1984), berenil and 4', 6-diamino-2'-phenylindone (DAPI) (Schmid et al., 1986, 1987a). FRA16B has also been induced with the anti-viral agent interferon (Thestrup-Pedersen et al., 1980; Shabtai et al., 1983, 1987), D287/170 (a derivative of DAPI), and methyl green (Schmid et al., 1986).

Berenil was the best inducing agent of FRA16B (Schmid et al., 1986). At a frequency of $\sim 1/20$ in the German population, FRA16B is the most common of the rare fragile sites (Table 1.1) (Schmid et al., 1986).

All the inducing agents with the exceptions of interferon and BrdU, bind externally and without intercalation to double stranded DNA with a strong preference for dA-dT sequences (Schmid et al., 1986; Zimmer, 1975). Daunomycin and quinacrine mustard, both dA-dT specific compounds, interact with DNA by intercalation (Waring, 1970). Both agents did not induce the expression of FRA16B (Schmid et al., 1986). Mithramycin and chromomycin A₃, both of which bind to dG-dC rich sequences, and the cytidine analogues 5-azaC and 5-aza-2'-deoxy-cytidine did not induce FRA16B (Schmid et al., 1986).

Schmid et al. (1986, 1987a) have suggested that FRA16B and FRA17A are regions of AT-rich repetitive DNA sequences that are late replicating in S phase. FRA16B may also be caused by integrated viral DNA (Sorensen et al., 1979; Sutherland, 1979).

Schmid et al. (1987b) showed that the rate of sister chromatid

exchange was increased at FRA16B following treatment with berenil and BrdU or with BrdU alone. Schmid et al. (1987b) suggested that FRA16B is a short AT-rich chromosome site, surrounded by euchromatin, with properties of high somatic recombination.

Individuals who are homozygous for FRA16B (Sutherland, personal communication) and FRA17A (Izakovic, 1984) have been identified indicating that homozygosity at these loci is not deleterious.

1.5.6 THE COMMON FRAGILE SITES

Human chromosomes contain spontaneous break-prone regions referred to as 'hot points' or 'hot spots' (Ayme et al., 1976). Expression of these regions can be induced by deprivation of folic acid (Zhou et al., 1982), MTX (Barbi et al., 1984), aphidicolin (Glover et al., 1984), caffeine (Yunis and Soreng, 1984), addition of uridine to folate free medium (Li and Zhou, 1985), 1- β -D-arabinofuranosyl-cytosine (araC) (Li et al., 1986a), or by the addition of cytidine or guanosine (but not adenosine or thymidine) to medium deprived of folic acid (Li et al., 1986b). These sites are referred to as common (Glover et al., 1984) or constitutive (Yunis and Soreng, 1984) fragile sites (Table 1.1).

The common fragile sites are induced in a small percentage of cells under thymidylate stress, but are more readily induced in a higher percentage of cells with the addition of aphidicolin (Glover et al., 1984). Since aphidicolin inhibits DNA polymerase α , an enzyme which is primarily associated with chromosomal DNA replication, Glover et al. (1984) suggested that the common fragile sites occur as a result of the inhibition of the replication fork progression or the joining of DNA replicative intermediates.

The addition of caffeine, an inhibitor of DNA repair mechanisms (Roberts, 1984), results in the expression of up to 51 additional sites

(Yunis and Soreng, 1984). Of these sites FRA3B and FRA16D are the most readily induced (Glover *et al.*, 1984) and FRA3B has been detected in every individual examined (Smeets *et al.*, 1986). The common fragile sites probably occur in the homozygous state in all individuals (Sutherland and Hecht, 1985).

Lin *et al.* (1987) demonstrated that the expression of uridine-induced common fragile sites could be inhibited or 'rescued' by the addition of thymidine 2-3 hours before harvesting the cells.

Daniel (1986) noted that six (and possibly more) common fragile sites were mapped to the same chromosomal position as the corresponding heritable rare fragile sites. Since both common and rare folate sensitive fragile sites have similar inducing conditions, Daniel (1986) concluded that a mutation at a common fragile site produces a rare heritable fragile site.

The other major type of common fragile sites are ones induced by 5-azaC, 5-8 hours prior to harvest, and BrdU 4-6 hours prior to harvest (Sutherland *et al.*, 1985b). The 5-azaC fragile site at 1q42 has a homologous band region in the genome of the gorilla and chimpanzee, whereas the one at 19q13 has a homologous band region in the gorilla only (Schmid *et al.*, 1985). These findings suggested that fragile sites may be conserved in chromosomally closely related species. Common fragile sites have been detected in the genome of the rat (Robinson and Elder, 1987).

1.5.7 GENERAL AIMS OF THE THESIS

The general aim of this study was to aid in the construction of a linkage map of chromosome 16 using RFLPs detected by anonymous DNAs, with emphasis in obtaining linked RFLPs to the fragile sites on this chromosome. Chromosome 16 has four fragile sites, two rare (FRA16A and

FRA16B) and two common (FRA16C and FRA16D) (Fig. 1.2) (Sutherland and Mattei, 1987). FRA16A is folate sensitive and is localized at band p13.11 (Callen *et al.*, 1988b). FRA16B is distamycin A inducible and is localized at band q22.100 (Magenis and Chamberlin, 1979). FRA16C and FRA16D are both aphidicolin inducible and are localized at bands q22.1 and q23.1 respectively (Yunis and Soreng, 1984). FRA16B and FRA16C map to identical regions (Yunis and Soreng, 1984). In addition, the short arm of chromosome 16 contains the α -globin gene complex (HBA) and the gene for PKD1 (reviewed in Sutherland *et al.*, 1987a).

At the commencement of this study, three anonymous DNAs and 27 genes and markers had been mapped to chromosome 16 (Cox and Gedde-Dahl, 1985). Chromosome 16 had few RFLP markers, which are needed for the construction of a detailed linkage map (1.4.7). There were no RFLPs closely linked to any of the fragile sites on this chromosome (Cox and Gedde-Dahl, 1985). The only linkage information between a chromosome 16 fragile site and a polymorphic marker was for HP and FRA16B (Magenis *et al.*, 1970). The genetic distance between these loci was calculated to be approximately 9 cM (Mulley, 1985b).

A linkage map of chromosome 16 based on anonymous DNAs detecting RFLPs would provide a powerful means for the localization and ordering of genes and additional anonymous DNAs. Closely linked and flanking RFLPs would be important in the eventual cloning of the fragile sites, and the clinically important PKD1 gene, on this chromosome using the new cloning and pulsed-field gel electrophoretic technologies (1.4.8).

There are several important advantages in working on chromosome 16. Chromosome 16 can be selected for in somatic cell hybrids, which allows for the construction of an extensive chromosome 16 mapping panel (Callen, 1986). This provides a relatively straightforward and rapid approach in mapping cloned chromosome 16 derived DNAs.

FIGURE 1.2

CHROMOSOME 16 SHOWING THE FOUR FRAGILE SITES

Chromosome 16 has four fragile sites (indicated by arrows), two rare (FRA16A and FRA16B) and two common (FRA16C and FRA16D). FRA16A is folate sensitive and is localized at band p13.11; FRA16B is distamycin A inducible and is localized at band q22.100; FRA16C and FRA16D are both aphidicolin inducible and are localized at bands q22.1 and q23.1 respectively.

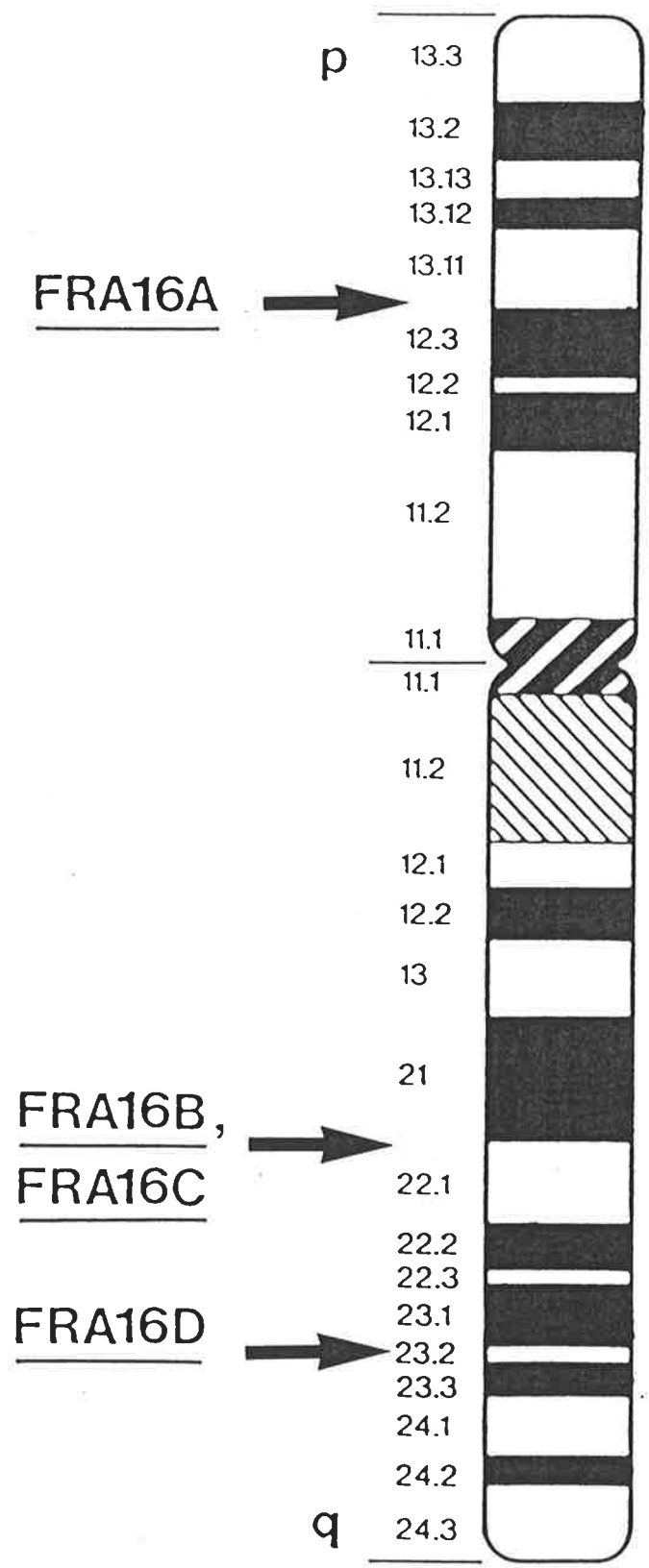

Chromosome 16 can be subdivided into four main regions, based on the precise cytogenetic localizations of the four fragile sites. Such divisions are useful for in situ hybridization studies to localize cloned anonymous DNAs mapping in the vicinity of fragile sites (Simmers, 1988). Combined with the subdivisions caused by the fragile sites, and the translocation breakpoints of the somatic cell hybrids (Table 2.2), chromosome 16 can be divided up to ten distinct regions in which anonymous DNAs can be mapped (Fig. 2.1).

Chromosome 16 can be identified cytologically without banding which is important for in situ hybridization analyses involving cloned genes or anonymous DNAs mapped with respect to the fragile sites (Callen et al., 1988a, 1988b; Simmers, 1988).

Finally, several FRA16A and FRA16B families had been ascertained by the Department of Cytogenetics as part of a research study on these two fragile sites, and these were available for the purpose of linkage analysis with DNA markers isolated from chromosome 16.

1.5.7.1 SPECIFIC AIMS OF THE THESIS

The specific aims of this project were:-

- (1) To construct a genomic λ Charon 4A library from the mouse-human hybrid cell line CY17 (WAIVA) to provide a source of large (15-20 kb) size chromosome 16 DNA fragments to be screened for RFLP detection.
- (2) To screen, isolate and plaque purify, from the recombinant library, putative human insert containing λ clones using the cloned Alu repetitive sequence probe, pBLUR8.
- (3) To use DNA pre-reassociation to mask out the repetitive sequences, such as Alu, but not the unique sequences in the λ clones for the purpose of using the entire clone for mapping

and searching for RFLPs without the need for subcloning.

- (4) To preliminary map isolated λ clones to either chromosome 16 or 22, since CY17 additionally contained human chromosome 22.
- (5) To regionally localize chromosome 16 clones using the extensive chromosome 16 hybrid cell panel.
- (6) To search for RFLPs, with special emphasis on λ clones regionally mapping in the vicinity of either FRA16A or FRA16B, by screening genomic DNA isolated from a panel of six unrelated Caucasians restricted with 8-23 different restriction enzymes.
- (7) To subclone unique fragments from polymorphic clones to appropriate plasmid vectors so that DNA pre-reassociation is no longer required.
- (8) To confirm the Mendelian inheritance of RFLPs by analyzing the informative families.
- (9) To do linkage studies with polymorphic clones mapping near FRA16A or FRA16B by analyzing the appropriate fragile site families.
- (10) To do linkage studies with RFLPs in the vicinity of FRA16A or FRA16B isolated by other researchers, so that the order of the loci could be determined.

The human haploid genome contains $\sim 3 \times 10^9$ bp of DNA (Mendelsohn et al., 1973). Human chromosome 16 contains $\sim 93 \times 10^6$ bp (93 cM) or 3.3 percent of the autosomal DNA content (Mendelsohn et al., 1973). Only five evenly spaced RFLPs, each 20 cM apart, would be required to span chromosome 16. However, as outlined in (1.4.7) many more RFLPs would have to be isolated than the theoretically calculated value to ensure a complete linkage map. The results presented in this thesis were part of an effort to achieve this goal.

CHAPTER 2
MATERIALS AND GENERAL METHODS

2.1 MATERIALS

2.1.1 CHEMICALS AND REAGENTS

All chemicals used were of analytical reagent grade, or of the highest available purity. The sources of the more important chemicals and reagents are listed below.

Agarose, nucleic acid grade: Pharmacia Fine Chemicals Ltd.

Agarose, low gelling temperature: Sigma.

Ampicillin: Sigma.

Bromophenol blue: B.D.H. Chemicals Ltd.

Chloramphenicol: Sigma.

Dextran Sulphate, Sodium Salt: Pharmacia Fine Chemicals Ltd.

dNTPs: P.L. Biochemicals Inc.

DTT: Sigma.

Ethidium bromide: Sigma.

Ficoll 400: Pharmacia Fine Chemicals Ltd.

Formamide: Sigma, deionized with mixed bed resin before use.

Mixed bed resin AG 501-X8 (D): Bio-rad.

PEG 6000: Sigma.

Phenol: B.D.H. Chemicals Ltd., redistilled and stored at -20°C .

PVP: Sigma.

Radiochemical, α - ^{32}P -dCTP (>1800 Ci/mmole): BRESATEC.

Random primer (DNase I digested calf thymus DNA): BRESATEC.

Sephadex G-50 (medium): Pharmacia Fine Chemicals Ltd.

SDS: Sigma.

Sucrose: Ajax Chemicals.

Tetracycline: Sigma.

Xylene Cyanol FF: Tokyo Kasei.

2.1.2 ENZYMES

All restriction endonucleases used in this study were obtained from either Boehringer Mannheim, I.B.I., or New England Biolabs. The remaining enzymes were obtained from the sources listed below.

Bacterial Alkaline Phosphatase (BAP): I.B.I.

E.coli Deoxyribonuclease I (DNase I): Boehringer Mannheim.

E.coli DNA polymerase I (Klenow fragment): Boehringer Mannheim.

Lysozyme (from chicken egg white): Boehringer Mannheim.

Proteinase K: Boehringer Mannheim.

RNase A (from bovine pancreas): Boehringer Mannheim., heat denatured at 100°C for 20 min to inactivate any contaminating DNases.

T4-DNA Ligase: Boehringer Mannheim.

2.1.3 BUFFERS

Buffers commonly used in this study were:

CLB: 320 mM sucrose, 10 mM Tris-HCl pH 7.5, 5 mM MgCl₂, 1% triton X-100.

PKB: 10 mM Tris-HCl pH 7.4, 10 mM NaCl, 10 mM EDTA.

PSB: 100 mM NaCl, 10 mM MgCl₂, 0.05% gelatin, 10 mM Tris-HCl pH 7.4.

SEP: 1% sarkosyl, 500 mM EDTA, 2% Proteinase K.

SET: 15% sucrose, 10 mM EDTA, 25 mM Tris-HCl pH 8.0.

SSC: 150 mM NaCl, 15 mM sodium citrate, pH 7.5.

TAE: 40 mM Tris-HCl pH 8.0, 20 mM sodium acetate, 2 mM EDTA.

TBE: 134 mM Tris-HCl pH 8.8, 45 mM boric acid, 3 mM EDTA.

TE: 10 mM Tris-HCl pH 7.5, 0.1 mM EDTA.

2.1.4 BACTERIAL MEDIA

All media were prepared with deionized water and sterilized by autoclaving. All bacteria were grown in L-broth or on L-agar or L-agarose plates. Where appropriate, the media was supplemented with

ampicillin or tetracycline (30 µg/ml) after the autoclaved media had cooled down to 55°C.

L-broth: 1% Bacto-tryptone (Difco), 0.5% Bacto-yeast extract (Difco), 1% NaCl, pH 7.0.

All plates were prepared from 30 ml (90 mm plate) or 80 ml (150 mm plate) of the relevant mixture, and were pre-dried at 37°C before use or were stored at 4°C until required.

L-agar plates: L-broth, 1.5% Bacto-agar.

L-agarose plates: L-broth, 1.5% agarose.

L-Amp plates: L-broth, 1.0% agarose, ampicillin (30 µg/ml).

L-Tet plates: L-broth, 1.0% agarose, tetracycline (30 µg/ml).

L-soft agarose: L-broth, 0.5% agarose, 10 mM MgSO₄.

2.1.5 BACTERIAL STRAINS

The E.coli K12 strains used in this study were:

LE392: F⁻, hsdR514(r_k⁻, m_k⁺), supE44, supF58, lacY1, or Δ(lacIZY)6, galK2, galT22, metB1, trp55, λ⁻. (Murray et al., 1977).

MC1061: araD139, Δ(ara, leu)7697, ΔlacX74, galU⁻, galK⁻, hsr⁻, hsm⁺, rpsL. (Casadaban and Cohen, 1980).

2.1.6 CLONING VECTORS

λ Charon 4A: Aam 32, Bam 1, lac5, bio256, VKH54, VNIN5, φ80, QSR. (Williams and Blattner, 1979). This vector was used for cloning genomic DNA from the mouse-human somatic cell hybrid CY17 (2.1.8).

The plasmid pSP64 (Amp^R) (Melton et al., 1984) was used to subclone fragments derived from λ clones.

2.1.7 NUCLEIC ACIDS AND CLONED DNA SEQUENCES

E.coli tRNA: Boehringer Mannheim.

Human Placental DNA, Sodium Salt: Sigma. The DNA (10 mg/ml in TE) was sonicated (or microwaved) until the DNA was < 1.0 kb in size, as described in Sealey et al. (1985).

λ Charon 4A EcoRI Arms: Amersham.

λ DNA: Bethesda Research Laboratories, Inc.

Molecular weight markers, λ DNA restricted with HindIII; SPP-1

Bacteriophage DNA restricted with EcoRI: BRESATEC.

pBR322 DNA: Boehringer Mannheim.

Salmon Sperm DNA, Sodium Salt: Calbiochem. The DNA (25 mg/ml in H₂O) was sonicated (or microwaved) and heat denatured prior to usage.

Huap15: gift from Dr. P. Stambrook.

pACHF1: gift from Dr. S. Reeders.

pA079: gift from Dr. W.J.M. Van de Ven.

pBLUR8: gift from Dr. P. Deininger.

2.1.8 HYBRID CELL LINES

The human chromosome(s) present in the mouse-human hybrid cell lines used in the study are summarized in Table 2.1. The portion of chromosome 16 present in the hybrid cell lines is shown in Table 2.2. The breakpoints of the chromosome 16 in the hybrids are shown with respect to the fragile sites on chromosome 16 (1.5.7) in Figure 2.1.

2.1.9 UTAH FAMILIES

The following Utah families, obtained from the NIGMS Human Genetic Mutant Cell Repository, Camden, N.J., were used in the study:

Family 981 (Utah pedigree K-1329), Family 982 (Utah pedigree K-1331), Family 983 (Utah pedigree K-1333), Family 984 (Utah pedigree K-1340),

TABLE 2.1

HUMAN CHROMOSOME(S) PRESENT IN MOUSE-HUMAN HYBRID CELL LINES

LINE	HUMAN CHROMOSOME(S)
CY2	der(X)t(X;16)(q26;q24).
CY3	der(16)t(X;16)(q26;q24).
CY5	der(10)t(10;16)(q22;q22).
CY6	der(10)t(10;16)(q24;q22), 8.
CY7	der(3)t(3;16)(q13.2;q13), 10, 12.
CY8	der(11)t(11;16)(q14;q12.1), 4, 7, 8, 20, 21.
CY11	der(16)t(11;16)(q21;p13.11).
CY13	der(16)t(1;16)(q44;p13.11), 3, 11, 14, 17, 20, 21, 22.
CY14	der(16)t(4;16)(q31;p13.3), 1, 4, 12, 14, 20, 21.
CY17 ^a	16, 22, and others?
CY18	16.
WEGROTH-D2 ^b	22.

^aAlso referred to as WAIVA (Deisseroth *et al.*, 1977).

^bHofker *et al.* (1987b).

TABLE 2.2

THE PORTION OF HUMAN CHROMOSOME 16 IN THE MOUSE-HUMAN
HYBRID CELL LINES

PORTION OF CHROMOSOME 16	CELL LINE	REFERENCE
16pter-→16qter	CY18	Callen (1986).
16pter-→16qter	CY17	Deisseroth <i>et al.</i> (1977).
16pter-→16q24	CY3	Callen (1986).
16p13.3-→16qter	CY14	Callen <i>et al.</i> (1988b).
16p13.11-→16qter	CY13	Callen (1986).
16p13.11-→16qter	CY11	Koeffler <i>et al.</i> (1981) ^a .
16q12.1-→16qter	CY8	Callen, unpublished.
16q13-→16qter	CY7	Callen (1986).
16q22.102-→16qter	CY6	Callen, unpublished.
16q22.1-→16qter	CY5	Callen (1986).
16q24-→16qter	CY2	Callen (1986).

^aBreakpoints were reassigned from 16p11.1-→16qter to
16p13.11-→16qter (Callen *et al.*, 1988b).

FIGURE 2.1

THE CHROMOSOME 16 HYBRID CELL LINES

The portion of each chromosome 16 present in the hybrid cell lines, referred to by a specific CY number, is shown in respect to the four fragile sites (FRA16A, FRA16B, FRA16C and FRA16D). The precise cytogenetic breakpoints of the hybrids is summarized in Table 2.2.

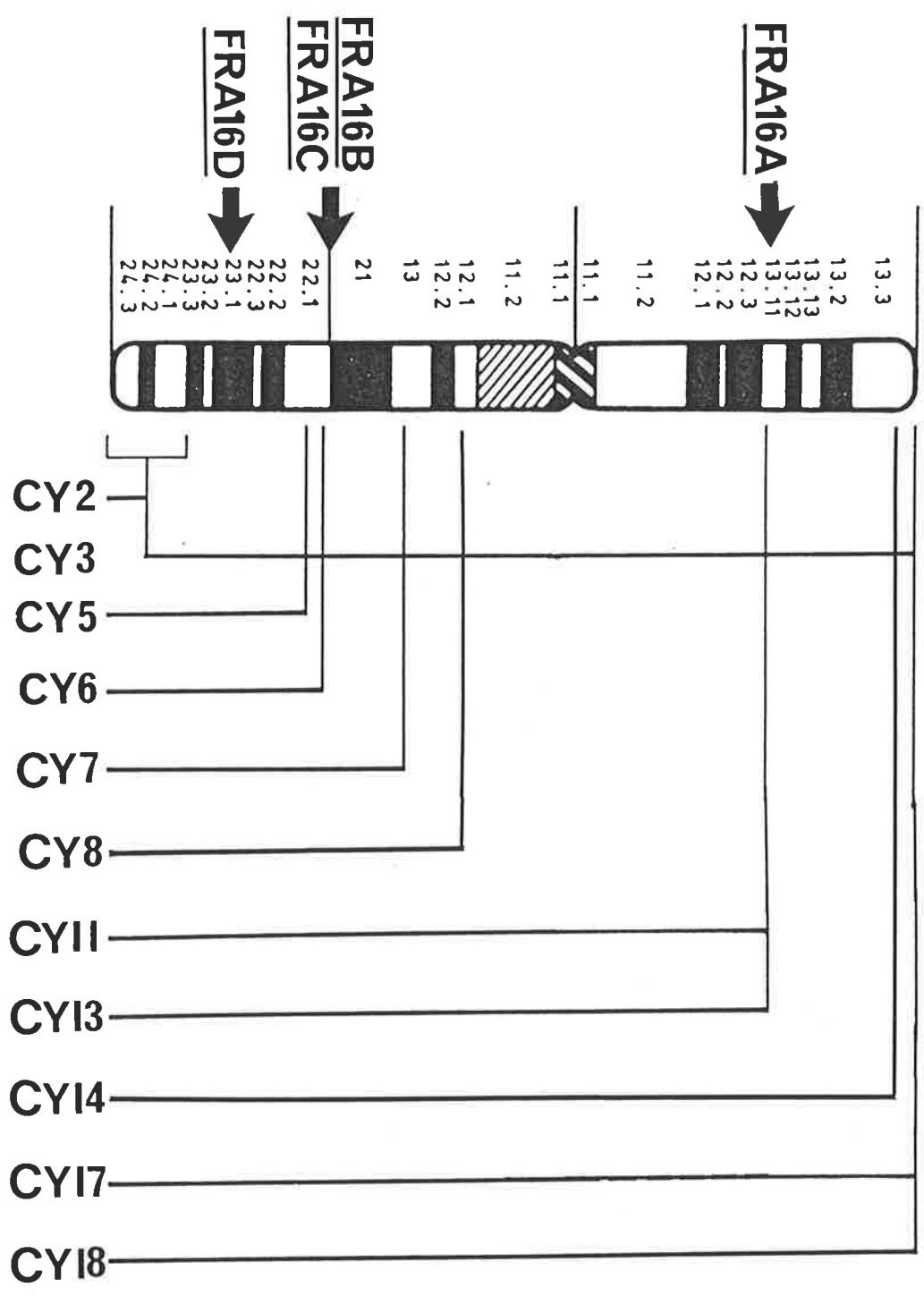

Family 985 (Utah pedigree K-1341), Family 1029 (Utah pedigree K-1345).

The pedigrees of the above families are shown in Appendix A.

2.1.10 FRAGILE SITE FAMILIES

The following FRA16A family was used in this study:

Pedigree - 10556.

The following FRA16B families were used in this study:

Pedigrees - 401, 4139, 12058, 12273, 16367, 16449, 16498, 16786, 16967, and 17043.

The pedigrees of the above families that are underlined are shown in Appendix B, since these families were informative in linkage analysis studies (Chapter 7).

2.1.11 MISCELLANEOUS MATERIALS

Cellophane dialysis tubing: B.D.H. The tubing was boiled in 2% sodium bicarbonate, 1 mM EDTA before use, and stored in 70% ethanol, 30% 50 mM Tris-HCl, 2 mM EDTA pH 7.5.

GeneScreen circular (137 mm) filters for plaque transfers: New England Nuclear (NEN).

GeneScreen Plus Hybridization Transfer Membrane: NEN.

Kodak X-OMAT X-ray film: Kodak Film Co. Ltd.

2.2 GENERAL METHODS

2.2.1 PREPARATION OF GLASSWARE AND SOLUTIONS

All solutions were prepared using deionized water and were autoclaved to render them nuclease-free. Where the solution was unable to withstand autoclaving, it was filtered through a Millipore (0.22 μ M) filter under suction. Glassware were sterilized by autoclaving. Spatulas, etc., were washed in 70% ethanol and rinsed in sterile water.

Buffer-saturated phenol (pH 7.5-8.0) was prepared as described by Maniatis et al. (1982).

2.2.2 PHENOL, CHLOROFORM-ISOAMYLALCOHOL EXTRACTIONS

In phenol extractions, a half volume of buffer-saturated phenol (pH 7.5-8.0) (Maniatis et al., 1982) was added to the sample, mixed and then centrifuged (5 min in an Eppendorf; 5 min in a bench top centrifuge). The upper aqueous phase was recovered and a half volume of chloroform-isoamylalcohol (24:1) was added, then carefully mixed and recentrifuged as described above. The upper aqueous phase was recovered.

2.2.3 ETHANOL PRECIPITATION

Samples were made 300 mM with respect to sodium acetate using a 3 M stock solution at pH 5.2, or alternatively, made 3.75 M with respect to ammonium acetate using a 7.5 M stock solution at pH 7.5. Two volumes of cold 99.9% ethanol were added to each sample and after mixing, the samples were either incubated at -20°C for at least 2 hours or chilled for 15 min in an ethanol-dry ice bath. Precipitates were collected by centrifugation at 12,000 rpm for 15 min in an Eppendorf centrifuge. The supernatant was removed with a drawn-out pasteur pipette and the pellet was washed with 1 ml of cold 70% ethanol and then desiccated for 5 min. The pellet was then resuspended in the appropriate solution.

2.2.4 PREPARATION OF HIGH-MOLECULAR-WEIGHT GENOMIC DNA

The following procedure, essentially as described in Wyman and White (1980), was used to isolated genomic DNA from human blood, mouse fibroblasts, and from various cell lines (2.1.8, 9 and 10).

2.2.4.1 ISOLATION FROM HUMAN BLOOD

Human bloods collected into 10 ml tubes (anticoagulant dipotassium EDTA) were obtained from the Red Cross Blood Centre, and placed into 50 ml Falconer tubes. Ten ml of CLB (2.1.3) were added to the empty tubes that contained the blood, emptied into the same Falconer tubes, and the volume adjusted to 25 ml with CLB. The tubes were left on ice for 30 min, then centrifuged at 3,500 rpm for 15 min at 4°C. The supernatant was removed down to the 5 ml mark and the volume readjusted to 25 ml with CLB. The tubes were recentrifuged as before, and the supernatant removed. The pellet was resuspended in 3.25 ml of PKB (2.1.3), and 500 µl of 10% SDS and 200 µl of Proteinase K (10 mg/ml in PKB) was added. The tubes were placed onto a rotating wheel and incubated at 37°C overnight. The samples were phenol and chloroform-isoamylalcohol (24:1) extracted (2.2.2), and ethanol precipitated (2.2.3) at room temperature. The DNA was spooled onto a pasteur pipette, transferred to an Eppendorf tube containing 1 ml of 70% ethanol, centrifuged for 1 min, and the supernatant removed. The pellet was desiccated for 5 min and resuspended in 100-250 µl TE. The yield of genomic DNA from 10 ml of blood was between 100-400 µg.

2.2.4.2 ISOLATION FROM CELL LINES

Confluent grown cells were trypsinized and placed into 50 ml Falconer tubes and centrifuged at 2,000 rpm for 10 min at 4°C. The supernatant was removed and the cell pellets were processed as described above. The final pellet was resuspended in 500-1000 µl TE.

The samples were treated with 100 µg DNase-free RNase A (10 mg/ml) for 3 hours at 37°C to remove contaminating RNAs and then phenol and chloroform-isoamylalcohol (24:1) extracted. The DNA solution was then placed into pre-treated dialysis tubing and dialysed against 5 l of TE

at room temperature for 16 hours, with at least one change of buffer. The DNA solution was removed from the dialysis tubes and then ethanol precipitated. The DNA pellet was resuspended in 500 μ l TE.

2.2.5 PREPARATION OF RECOMBINANT PHAGE DNA

Phage DNA was prepared by a modification of the plate lysate method as described in Maniatis *et al.* (1982). In a sterile 10 ml tube, 20 μ l of a high titre phage stock of the purified recombinant λ clone (3.2.3) was mixed with 300 μ l of *E.coli* LE392 plating bacteria, prepared as described by Maniatis *et al.* (1982), and 80 μ l PSB (2.1.3). The tube was incubated at 37°C for 20 min then 7.5 ml of molten L-soft agarose (2.1.4), at 47°C, was added to the tube, mixed, then spread onto a 150 mm L-agarose plate (2.1.4). The set plate was inverted and incubated at 37°C overnight. The plate was flooded with 10 ml PSB and left for 30 min before the agarose overlay was transferred into a 50 ml centrifuge tube. The plate was again flooded with 10 ml of PSB, left for 5 min, collected into the same tube and then centrifuged for 8,000 rpm for 10 min at 4°C. The supernatant was carefully decanted into a fresh tube and the agarose/debris pellet was resuspended in 10 ml PSB, recentrifuged, and the supernatant combined with the first. The supernatant was centrifuged at 25,000 rpm for 2 hours at 4°C and the pellet, containing the phage, was resuspended in 1 ml of 10 mM MgCl₂, 50 mM Tris-HCl pH 7.5 and left overnight at 4°C to resuspend. The suspension was treated with 50 μ g of DNase-free RNase A (10 mg/ml) for 1 hour at 37°C, then with 100 μ g of Proteinase K (10 mg/ml) and 100 μ l 10% SDS for 1 hour at 65°C. The phage suspension was extracted twice with phenol, once with chloroform-isoamylalcohol (24:1) (2.2.2) and then dialysed overnight at room temperature. The sample was then ethanol precipitated and the phage DNA pellet resuspended in 100 μ l TE. This procedure yielded up to

100 µg of DNA from a 150 mm LB-agarose plate.

2.2.6 PREPARATION OF RECOMBINANT PLASMID DNA

2.2.6.1 LIQUID CULTURE METHOD

A single colony of *E.coli*, containing the plasmid to be amplified, was used to inoculate 10 ml of L-broth (2.1.4). The appropriate antibiotic (ampicillin or tetracycline, 30 µg/ml) was included in the broth to maintain selective pressure for the retention of the plasmid. The culture was then incubated at 37°C overnight with vigorous shaking. The overnight culture was transferred to a flask containing 600 ml of L-broth and grown at 37°C to an OD₆₀₀ of ~1.0. Chloramphenicol (RNase free) was added to a final concentration of 150 µg/ml and incubation continued overnight. The bacteria were harvested by centrifugation at 4,000 rpm for 10 min at 4°C. The plasmid DNA was isolated by a modified method of Birnboim and Doly (1979). The cell pellets were resuspended in 4 ml of SET (2.1.3) and 8 mg of powdered lysozyme was added and the tubes were incubated on ice for 30 min. Eight ml of 0.2 M NaOH, 1% SDS was added to the suspension and left on ice for 10 min. Five ml of 3 M sodium acetate, pH 5.2, was added and the tubes were gently inverted several times. The tubes were incubated on ice for 40 min then centrifuged at 15,000 rpm for 15 min at 4°C. The supernatant, containing plasmid DNA, was carefully removed and treated with 50 µl of DNase-free RNase A (1mg/ml) for 20 min at 37°C, phenol and chloroform-isoamyl-alcohol (24:1) extracted (2.2.2) and then ethanol precipitated (2.2.3). The pellet was resuspended in 1.6 ml of H₂O, and 400 µl of 4 M NaCl, and 2 ml of 13% PEG 6000 was added. The solution was incubated on ice for 1 hour. After centrifugation at 10,000 rpm for 10 min at 4°C, the PEG supernatant was removed and the pellet washed in 70% ethanol and then desiccated for 5 min. The pellet was resuspended in 500 µl TE.

This method yielded between 250-500 μg of plasmid DNA from a 600 ml culture.

2.2.6.2 PLATE ISOLATION METHOD

This method involved the isolation of plasmid DNA from bacterial cells plated onto L-agar plates supplemented with the appropriate selective antibiotic (2.1.4), and was devised from a modification of the method of Birnboim and Doly (1979).

A single E.coli colony containing the plasmid to be isolated was streaked out onto an antibiotic supplemented L-agar plate (90 mm) and incubated at 37°C overnight. The bacteria were harvested by using a sterile spatula and resuspended into 2 ml of 50 mM Tris-HCl pH 8.0, 20 mM EDTA in a 10 ml centrifuge tube. The cells were pelleted by centrifugation at 12,000 rpm for 30 sec at 4°C and resuspended in 600 μl of 50 mM Tris-HCl pH 8.0, 20 mM EDTA and 50 mM glucose to which 30 μl of lysozyme (80 mg/ml) was added. The tube was gently mixed, incubated at room temperature for 5 min then on ice for 1 min. 1.2 ml of 0.2 M NaOH, 1% SDS was added, the tube mixed gently, and incubated on ice for 5 min. To this was added 900 μl of ice cold 3 M potassium acetate pH 4.3, and the tube was mixed and left on ice for 10 min. The tube was centrifuged at 12,000 rpm for 15 min at 4°C, then the supernatant was removed into a fresh tube and recentrifuged as above. The supernatant was transferred to a fresh tube to which 5.5 ml of 99.9% ethanol (at room temp.) was added and incubated at room temperature for 5 min. The tube was centrifuged at 12,000 rpm for 5 min and the supernatant was removed and the pellet washed in 2 ml of 70% ethanol. The pellet was desiccated for 5 min and resuspended in 200 μl of TE and treated with 10 μg of DNase-free RNase A (1mg/ml) for 15 min at 37°C. The sample was phenol and chloroform-isoamylalcohol (24:1) extracted (2.2.2) and ethanol precip-

itated using ammonium acetate (2.2.3). The pellet was resuspended in 100-200 μ l TE. This method yielded between 200-500 μ g of plasmid DNA per 90mm plate.

This method was scaled down so that up to 12 different preparations could be processed at once. All volumes were scaled down by a factor of four and the bacteria were harvested from only a quarter of a 90 mm plate. All manipulations and centrifugation steps could be done using Eppendorf tubes. The yields from such minipreps was between 5-10 μ g.

2.2.7 QUANTITATION OF DNAs

The concentration of genomic DNAs was determined spectrophotometrically, essentially as described in Maniatis et al. (1982), assuming that one A_{260} unit equals 50 μ g/ml for double-stranded DNA. The concentration of plasmids and λ DNAs were determined by agarose gel electrophoreses (2.2.9). Briefly, various dilutions of digested plasmid DNA (2.2.8), linearized with the appropriate enzyme, were co-electrophoresed with known amounts of molecular weight markers (2.1.7) and the intensity of a similar size molecular weight marker fragment was used to determine the concentration of the plasmid. For λ DNAs, various dilutions of the uncut λ DNA were co-electrophoresed with various dilutions of λ DNA (2.1.7) of known concentration.

2.2.8 RESTRICTION ENDONUCLEASE DIGESTIONS OF DNA

Restriction endonuclease digestion of DNA was carried out using the three buffer system of Maniatis et al. (1982). Generally, four units of enzyme was added for each microgram of DNA to be digested and the reaction mix was incubated for at least 12 hours for genomic DNAs (plasmid and λ DNA digests were incubated for 2-4 hours) to ensure

complete digestion. Plasmid and λ DNA digests also contained spermidine to aid the digestion (Bouche, 1981; Pingoud, 1985), if the buffer was either 'Medium' (5 mM spermidine, final concentration) or 'High' (10 mM spermidine, final concentration). Reactions were terminated by the addition of 0.1 volumes of 10 x agarose gel loading mix (25% ficoll 400, 0.2% bromophenol blue, 0.2% xylene cyanol FF).

2.2.9 AGAROSE GEL ELECTROPHORESIS OF DNA

Electrophoresis of DNAs for analytical purposes (checking digestions of DNAs, etc.) was carried out using agarose (0.8-1.0%) dissolved in 1 x TBE buffer (2.1.3) and cast on 10.5 cm x 8 cm x 0.2 cm glass plates. DNA samples that were to be used for Southern blots (2.2.11) were electrophoresed on either 10.5 cm x 8 cm x 0.2 cm glass plates (for digests of plasmids and λ DNAs) or in 14 cm x 11 cm x 0.3 cm and 17 cm x 14 cm x 0.3 cm perspex horizontal casts (for digests of genomic DNAs). Electrophoresis was performed in BRL or Pharmacia horizontal tanks containing 1 x TBE buffer, at 15-100 mA, until the bromophenol blue had migrated an appropriate distance to ensure that adequate separation of the DNA fragments had taken place. DNA was visualized under UV light after staining the gel in a 0.02% ethidium bromide solution for 10 min.

2.2.10 ISOLATION OF DNA FRAGMENTS FROM AGAROSE GELS

Low gelling temperature agarose was dissolved in 1 x TAE buffer (2.1.3) and cast on 8.0 cm x 4.0 cm x 0.2 cm glass plates. Electrophoresis was performed as described (2.2.9) except that the buffer was 1 x TAE, and that the current did not exceed 50 mA. Restriction fragments to be isolated were detected under UV light after brief ethidium bromide staining, and the desired bands were excised from the gel. The

DNA in the gel slice was isolated using a GENE CLEAN Kit (BIO 101, obtained through BRESATEC). Approximately 50-70% of the DNA was recovered and the elution volume was sufficiently small (10-20 μ l) that ethanol precipitation was not required.

2.2.11 TRANSFER OF DNA TO GENESCREEN PLUS

Restricted DNA fractionated in agarose gels was transferred to GeneScreen Plus membranes using the method of Southern (1975), as modified by Wahl *et al.* (1979). The filters were stored in a sealed plastic bag at room temperature until required.

2.2.12 PREPARATION OF RADIOACTIVE DNA PROBES

2.2.12.1 NICK-TRANSLATION OF DOUBLE-STRANDED DNA

The labelling of double-stranded DNA using *E. coli* DNA polymerase I (Rigby *et al.*, 1977) was carried out using a nick-translation kit (BRESATEC). The 20 μ l reaction mix contained 25 μ M of unlabelled dATP, dGTP, and dTTP, 50 mM Tris-HCl pH 7.6, 10 mM $MgSO_4$, 0.1 mM DTT, 50 μ g/ml gelatin, 40-500 ng DNA, 50 μ Ci α -³²P-dCTP, 40 pg DNase I, and 5 units of *E. coli* DNA polymerase I. The mixture was incubated at 14°C for 90 min, after which it was terminated by the addition of EDTA to 20 mM. The mixture was then either (1) passaged through a Sephadex G-50 column to remove the unincorporated nucleotides, or (2) ethanol precipitated (2.2.3) with the addition of 25 μ g *E. coli* tRNA, or (3) directly used without any purifications. The labelled DNA had a specific activity of $1-5 \times 10^8$ cpm/ μ g.

2.2.12.2 OLIGO-LABELLING OF DNA RESTRICTION FRAGMENTS

DNA fragments isolated from agarose gel slices (2.2.10) were oligo-labelled (Feinberg and Vogelstein, 1983) using random oligonucleotide

primers and E.coli DNA polymerase I (Klenow fragment). In an Eppendorf tube, 20-60 ng of DNA and 5 ng of random oligonucleotide primer (2 ng/ μ l) was mixed (final volume of 11.5 μ l) and heated to 95°C for 2 min, then chilled on ice. This mix was added to an Eppendorf tube containing 50 μ Ci of dried down α -³²P-dCTP. 12.5 μ l of Nucleotide/Buffer Cocktail (20 μ M of unlabelled dATP, dGTP, and dTTP, 50 mM Tris-HCl pH 7.6, 50 mM NaCl, 10 mM MgCl₂, and 100 μ g/ml gelatin) and 5.0 units of E.coli DNA polymerase I (Klenow fragment) was added to commence the reaction. The tube was incubated at 40°C for 20 min, after which the reaction was terminated by the addition of EDTA to 20 mM. The sample was then passaged through a Sephadex G-50 column to remove the unincorporated nucleotides. The labelled DNA had a specific activity of $\sim 5 \times 10^8$ cpm/ μ g.

2.2.13 PRE-REASSOCIATION OF REPETITIVE DNA CLONES

³²P-labelled λ clones (2.2.12) were pre-reassociated prior to using them for DNA hybridizations (Sealey et al., 1985). Essentially, the labelled clone (60-500 ng) was mixed with a 2,000 fold excess of shDNA (5 μ g/ μ l) or a 2,000 fold excess of shDNA and smDNA, and made 5 x SSC. The sample was boiled for 10 min, cooled on ice for 1 min then incubated at 68°C for 2 hours. The mixture was then added to prewarmed hybridization mix, and applied to the Southern blot filters (2.2.14).

2.2.14 HYBRIDIZATION OF RADIOACTIVE DNA PROBES

The prehybridization and hybridization of ³²P-labelled probes to DNA immobilized on GeneScreen filters was carried out essentially as described in Wahl et al. (1979). Both the prehybridization and hybridization mixes were composed of 50% deionized formamide, 5 x SSC, 0.5% SDS, 1 x Denhardt's solution (0.02% PVP, 0.02% BSA, 0.02% ficoll 400),

100 µg/ml salmon sperm DNA, and 10% dextran sulphate. Generally, the filters were prehybridized overnight and then hybridized with the heat denatured probes (10 ng/ml), for at least 16 hours at 42°C in an orbital incubator.

After the hybridization step the filters were given the following stringency washes:

- (1) Low : 2 x SSC, 0.1% SDS, room temperature, 20 min.
- (2) Moderate : 2 x SSC, 0.5% SDS, room temperature, 20 min.
- (3) High : 0.1 x SSC, 0.1% SDS, 65°C, 30 min.

The final wash was repeated if the filter backgrounds were still considered high. After the washes the filters were semi-dried, covered with plastic wrap, and enclosed in an autoradiography cassette (with a Cronex DuPont Lightning Plus intensifying screen) with a sheet of X-ray film at -70°C for 1-12 days. After exposure, the X-ray film was developed, fixed, washed, and dried automatically.

Filters were reused by incubating them in 100 ml of 0.4 N NaOH at 42°C for 30 min with gentle agitation, followed by an incubation in 100 ml of 0.1 x SSC, 0.1% SDS, 0.2 M Tris-HCl, pH 7.5 at 42°C for 30 min. Filters were blotted dry and checked for radioactivity and rewashed if required.

2.2.15 SUBCLONING OF DNA FRAGMENTS INTO PLASMID VECTORS

2.2.15.1 PREPARATION OF VECTOR DNA

pSP64 DNA (2 µg) was restricted with the appropriate enzyme(s) to generate the desired cloning termini (2.2.8) and then dephosphorylated with bacterial alkaline phosphatase (BAP) in a 100 µl reaction mix containing 500 mM Tris-HCl pH 8.0, 500 mM NaCl, and 0.15 units of enzyme. After a 1 hour incubation at 65°C, 5 µl of SEP (2.1.3) was

added and the sample incubated at 37°C for 30 min to inactivate the BAP. The linearized dephosphorylated vector DNA was purified from any uncut vector by agarose gel electrophoresis (2.2.9). The vector DNA was resuspended in TE at a concentration of 50 ng/μl.

2.2.15.2 PREPARATION OF INSERT DNA

Restriction fragments to be subcloned were excised and isolated from low gelling temperature agarose gels (2.2.10).

2.2.15.3 DNA LIGATIONS

The DNA fragment and the appropriate pSP64 vector were combined in a molar ratio of approximately 3:1 in a 20 μl reaction mixture containing 50 ng vector, 50 mM Tris-HCl pH 7.5, 10 mM MgCl₂, 1 mM ATP, 1 mM DTT, 0.01 units T4-DNA ligase and the DNA fragment to be cloned. Ligations were carried out at 4°C for 16 hours.

2.2.15.4 BACTERIAL TRANSFORMATIONS

E.coli MC1061 cells were made competent using a modification of the method by Maniatis et al. (1982). The competent cells were resuspended in 100 mM CaCl₂, 20% glycerol, dispensed in 200 μl aliquots and stored at -70°C until required. To transform the cells, 10 μl of the ligation mix (2.2.15.3) was added to a thawed Eppendorf tube of cells and incubated on ice for 1 hour, with an occasional mixing. The mixture was placed at 42°C for 2 min then incubated on ice for 10 min. One ml of prewarmed L-broth was added and the tube incubated at 37°C for 1 hr. The tube was centrifuged for 30 sec, the supernatant discarded and the pellet resuspended in 50 μl L-broth. A 1/10 dilution of the sample was plated out onto a L-Amp plate and incubated overnight at 37°C.

2.2.15.5 DETECTION OF RECOMBINANT PLASMIDS

Putative recombinants derived from (2.2.15.4) were isolated, restreaked onto fresh L-Amp plates (four/plate), and incubated at 37°C overnight. Mini-preps of the samples were done (2.2.6.2) and restriction enzyme digests (2.2.8) of the plasmid DNAs were performed to determine which colonies were true recombinants. Such colonies were replated and plasmid DNA prepared (2.2.6.2).

2.2.16 COMPUTER PROGRAMS

The program used to calculate the lod score values in the fragile site families (2.1.10) was called LIPED (Version 3) (Ott, 1974, 1976). The program used to calculate molecular weights (kb) of DNA restriction fragments was called DNASIZE (kindly provided by Dr. V. Hyland).

2.2.17 CONTAINMENT FACILITIES

All work involving recombinant DNA material was carried out in accordance with the regulations and approval of the Australian Academy of Science Committee on Recombinant DNA and the Council of the University of Adelaide.

All work involving use of ionizing radiation was carried out under the Ionizing Radiation Regulations (1985) pursuant to the Radiation Protection and Control Act (1982) of South Australia.

CHAPTER 3

CONSTRUCTION AND SCREENING OF THE CY17 RECOMBINANT LIBRARY

3.1 INTRODUCTION

Anonymous DNA probes, used to identify RFLP loci in the human genome, have been isolated from a number of different recombinant libraries, both genomic and cDNA (1.4.4). Genomic DNA libraries contain all of the possible clonable sequences in the genome (Maniatis et al., 1978). This includes both single-copy DNAs, constituting 60 percent of the genome and various repetitive DNAs that collectively represent 40 percent of the genomic DNA (Schmidtke and Epplen, 1980).

A cDNA library is representative of the mRNA sequences expressed in the cell type from which it was derived and generally contains between $1-2 \times 10^3$ different recombinants (Williams, 1981). A cDNA library contains few repetitive DNA sequences compared with a genomic DNA library and therefore provides a good source of single-copy gene specific probes (Davies, 1981). However, the sequences which constitute the cDNA library are more highly conserved than non-transcribed DNA sequences and are generally less polymorphic than clones derived from genomic libraries (Davies, 1981; Helentjaris and Gesteland, 1983).

When RFLPs are to be isolated from a single human chromosome, the most efficient strategy involves the use of somatic cell hybrids containing the desired chromosome in a rodent cell background (Bufton et al., 1986; Carlock et al., 1985; Cavenee et al., 1984; Gusella et al., 1980; Scheffer et al., 1986). The same approach was used to construct a specific library to identify RFLP loci in the vicinity of the Huntington disease gene (Wasmuth et al., 1986). In the latter case, a hybrid cell line that contained the chromosomal region of interest translocated onto another human chromosome was used.

A large number of clones need to be screened when using somatic cell hybrid libraries, since the proportion of human clones to rodent clones is usually about one percent (Gusella et al., 1980; Wasmuth et

al., 1986).

An alternative approach is to initially purify the chromosome of interest by FACS, and then prepare suitable recombinant libraries (Davies et al., 1981; Van Dilla et al., 1986). Such libraries usually contain other co-sorted chromosomes and the majority of the clones contain small inserts (<4 kb) due to the cloning methods used for the library construction (Hyland et al., 1988a). The findings of Donis-Keller et al. (1986), Feder et al. (1985), Schumm et al. (1988) and Skolnick and White (1982) have indicated that large size (10-20 kb) genomic DNA probes are the most efficient for the detection of RFLPs.

Recombinant clones containing human inserts, derived from libraries constructed from hybrid cell lines, can be readily isolated by the use of differential hybridization techniques (1.4.4). Cavenee et al. (1984), Gusella et al. (1980) and Wasmuth et al. (1986) retrieved human clones from hamster-human libraries by probing with ³²P-labelled, nick-translated, total human genomic DNA. Alternatively, human clones could be isolated from somatic cell libraries, by the use of the cloned human specific Alu repetitive sequence probe, pBLUR8 (Porteous, 1986; Scheffer et al., 1986). Using either total human genomic DNA (Carlock et al., 1985) or pBLUR8 (Scheffer et al., 1986) were equally as effective in terms of isolating human clones from the somatic cell hybrid libraries.

Recombinant clones containing repetitive sequences such as Alu can be regionally mapped to specific chromosomes and be utilized for the search of RFLPs without the need to subclone single copy fragments (Barker et al., 1985; Fisher et al., 1984; Sealey et al., 1985).

This chapter details the construction and screening of a λ Charon 4A genomic library from the mouse-human hybrid cell line CY17 (2.1.8). This library was constructed to provide a source of human chromosome 16 DNA fragments, in the size range of 15-20 kb, for the purpose of (1)

aiding in the construction of a linkage map of this chromosome and (2) obtaining linked RFLPs to the fragile sites on this chromosome (1.5.7).

The cell line CY17 (Table 2.1) contained human chromosomes 16 and 22 in a mouse cell background (Deisseroth *et al.*, 1977) and was the only available cell line at the commencement of the project, that contained an intact chromosome 16. The cell line was karyotyped by Deisseroth *et al.* (1977) and found to contain chromosome 16 in 59 percent of cells, and chromosome 22 in 28 percent of cells.

The presence of other human chromosomes was not detected, although the possibility that there were translocations of portions of human chromosomes onto mouse chromosomes was not examined (Chapter 4). CY17 was also karyotyped in our Department (Callen, personal communication) and is shown in Figure 3.1.

3.2 METHODS

3.2.1 SOUTHERN BLOT ANALYSIS OF CY17

Genomic DNA (15 µg) from A9, CY17, CY18, WEGROTH-D2 (2.1.8) and a human sample (10 µg) was restricted to completion with TaqI (2.2.8), electrophoresed in an agarose gel (2.2.9) and then Southern blotted (2.2.11). The filter was prehybridized then hybridized (2.2.14) with ³²P-labelled, nick-translated (2.2.12.1), pA079. pA079 contains a 1.3 kb BamHI/HindIII restriction fragment derived from the 5' region of the human c-sis oncogene (van den Ouweland *et al.*, 1985) which has been mapped to chromosome 22 (Dalla Favera *et al.*, 1982).

A duplicate filter, as prepared above, was hybridized with ³²P-labelled, nick-translated, Huap15. Huap15 contains a 2.2 kb BamHI fragment derived from the human adenine phosphoribosyltransferase (APRT) gene (Stambrook *et al.*, 1984) which has been mapped to chromosome 16 (Tischfield and Ruddle, 1974).

FIGURE 3.1

METAPHASE SPREAD OF CY17

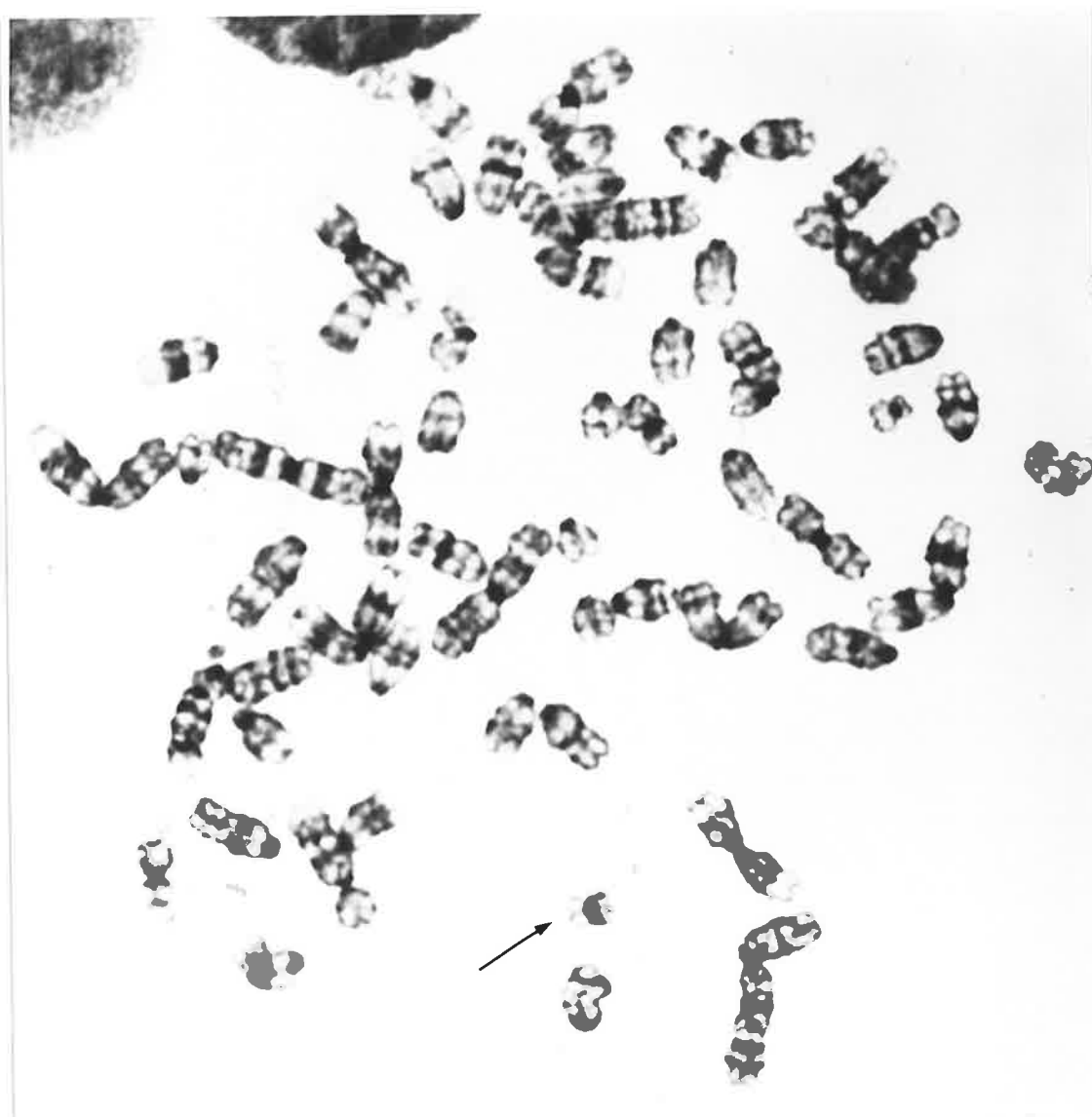

A G banded preparation of the hybrid cell line, CY17, showing human chromosome 16 (denoted by arrow). The remaining chromosomes are mouse. (Photo kindly provided by Dr. D. Callen).

3.2.2 PREPARATION OF THE CY17 GENOMIC LIBRARY

High-molecular-weight genomic DNA from CY17 was prepared, RNase A treated and extensively dialysed (2.2.4.2). The ethanol precipitated (2.2.3) DNA pellet was desiccated and redissolved in TE buffer (2.1.3). The concentration was determined spectrophotometrically (2.2.7) and was adjusted to $\sim 1.0 \mu\text{g}/\mu\text{l}$. The integrity of the DNA was judged by agarose gel electrophoresis (2.2.9). Ten micrograms of CY17 genomic DNA was digested to completion with EcoRI (2.2.8), phenol-chloroform extracted, chloroform-isoamylalcohol (24:1) extracted (2.2.2) and ethanol precipitated. The precipitated DNA was centrifuged, washed in 70% ethanol and resuspended in TE at a final concentration of $250 \text{ ng}/\mu\text{l}$.

Six hundred and seventy nanograms of EcoRI digested CY17 DNA was ligated with $1.33 \mu\text{g}$ of λ Charon 4A EcoRI arms (2.1.6) in 66mM Tris pH7.5, 5mM MgCl_2 , 1mM ATP, 20mM DTT and $3 \mu\text{l}$ T4-DNA ligase (0.9 Weiss units/ μl) at 12°C for 16 h. Six hundred nanograms ($3 \mu\text{l}$) of the ligation mix was used for in vitro encapsulation with Packagene extract (Promega Biotec) using the manufacturer's recommended procedure. The packaged phage were propagated on E.coli LE392 (2.1.5). The library was not amplified in order to avoid possible recombination between phages and possible loss of sequences through differential growth (Maniatis et al., 1982).

3.2.3 SCREENING OF THE CY17 GENOMIC LIBRARY

The entire library ($\sim 2.6 \times 10^4$ pfu) was plated out onto E.coli LE392, at a density of $\sim 2 \times 10^3$ pfu/150 mm L-agarose plate (2.1.4), and incubated overnight at 37°C . Duplicate plaque lifts, from each plate, were taken onto GeneScreen membranes essentially as described by Benton and Davis (1977).

The phage were adsorbed to GeneScreen membranes (1 min for the

first filter, 2 min for the second), denatured by soaking in 0.5 M NaOH, 1.5 M NaCl for 2 min, neutralized with two by 2 min washes with 0.5 M Tris-HCl pH 7.5, 1.5 M NaCl and blotted dry. The filters were placed back to back (DNA side facing out), prehybridized and hybridized (2.2.14) with ^{32}P -labelled, nick-translated (2.2.12.1), pBLUR8. Hybridization signals were usually observed after 4 hours of autoradiography (Fig. 3.2). Plaques which gave positive signals were picked into 1 ml PSB (2.1.3) and were purified by two additional rounds of platings (usually several hundred plaques on a 90 mm L-agar plate) and rescreening with pBLUR8. High titre phage stocks of purified recombinants were obtained by flooding a 90 mm L-agarose plate, on which the recombinant had been plated at high density ($\sim 10^5$ pfu), with two 2 ml washes of PSB. The recovered washes usually contained about 10^{10} pfu/ml and were filtered through 44 μm millipore filters and stored at 4°C with several drops of chloroform. Phage mini-preps (Maniatis *et al.*, 1982) consistently produced low yields of DNA that restricted poorly, hence DNA was prepared as described (2.2.5).

3.2.4 RESTRICTION ANALYSIS OF RECOMBINANT CLONES

DNA (0.5 μg) from each clone was restricted with EcoR1 (2.2.8), electrophoresed in 0.7% agarose gels and stained with ethidium bromide (2.2.9) to determine the size (kb) and number of inserts. The gels were transferred onto GeneScreen Plus membranes (2.2.11), and probed with ^{32}P -labelled, nick-translated (2.2.12.1), pBLUR8 to determine which restriction fragment(s) contained human Alu repetitive sequences. The filters were stripped washed (2.2.14), and reprobbed with ^{32}P -labelled, nick-translated, total mouse genomic DNA to determine which restriction fragment(s) contained mouse repetitive sequences (Fig. 3.3).

FIGURE 3.2

IDENTIFICATION OF HUMAN GENOMIC λ CLONES CONTAINING SEQUENCES
COMPLEMENTARY TO THE HUMAN ALU REPEAT CLONE, pBLUR8

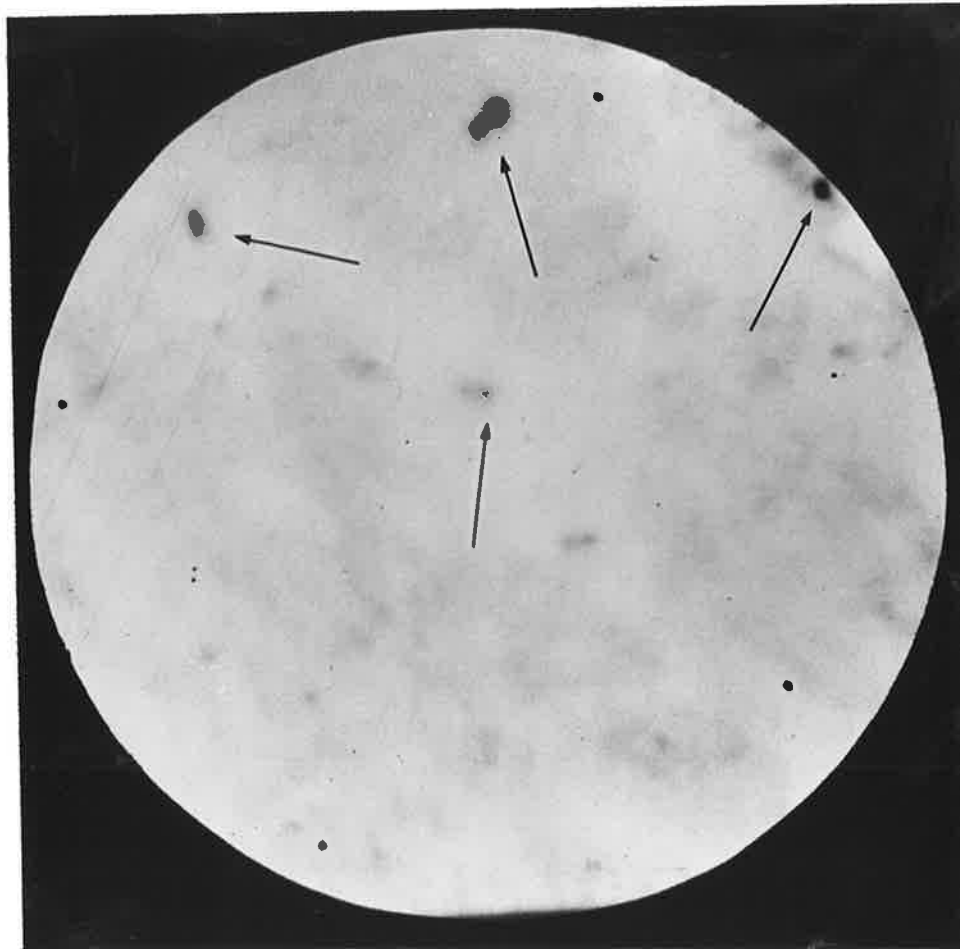

Recombinant phage from the CY17 library were plated out onto E.coli LE392, at a density of $\sim 2 \times 10^3$ pfu/150 mm L-agarose plate (3.2.3). The plaques were transferred onto GeneScreen membranes. The filters were prehybridized, then hybridized with ^{32}P -labelled, nick-translated, pBLUR8. The filters were washed and then exposed to Kodak X-omat X-ray film, using an intensifying screen at -70°C , for four hours. Some of the plaques which hybridized to pBLUR8 are shown in the autoradiograph (denoted by arrows). The hybridizing plaques were isolated from the plates and subjected to two additional rounds of screening with pBLUR8.

FIGURE 3.3

IDENTIFICATION OF HUMAN Alu AND MOUSE REPETITIVE FRAGMENTS IN THE λ CLONES FROM THE CY17 LIBRARY

DNA (0.5 μ g) from each λ clone (1: λ 73; 2: λ 249; 3: λ 30; 4: λ 76; 5: λ 204) was restricted with EcoRI, electrophoresed in 0.7% agarose gels and stained with ethidium bromide. The gel was transferred onto a GeneScreen Plus membrane and probed with 32 P-labelled, nick-translated, pBLUR8 to determine which restriction fragment(s) contained human Alu repetitive sequences. The filter was exposed for 3 hours at -70°C and then developed. The molecular weights (kb) of the human Alu fragments in the clones is shown.

The filter was stripped washed and reprobbed with 32 P-labelled, nick-translated, total mouse genomic DNA to determine which restriction fragment(s) contained mouse repetitive sequences. The filter was exposed for 7 days at -70°C and then developed. Only sample 4 (λ 76) contained a mouse repetitive fragment.

The data on all the λ clones is summarized in Table 3.1.

M: molecular weight marker - λ HindIII digest (only visible on the ethidium bromide stained gel).

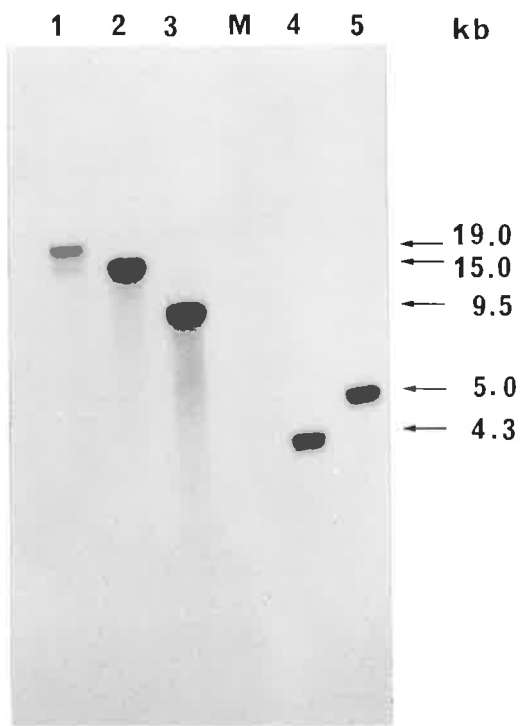

pBLUR8

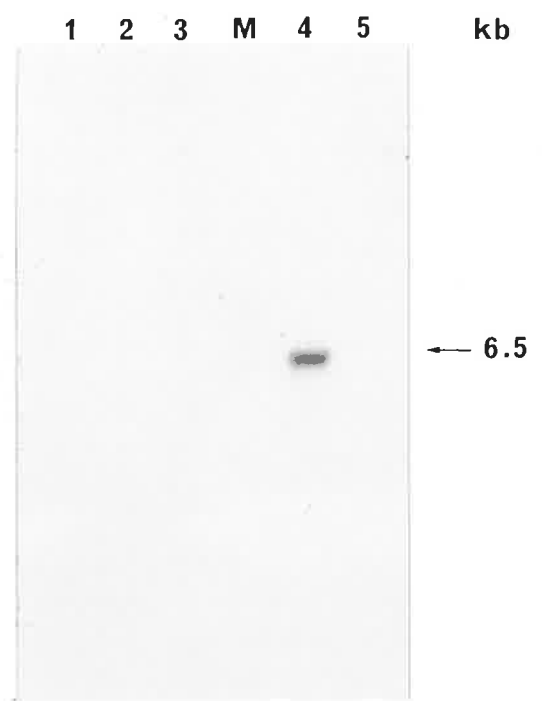

MOUSE DNA

3.3 RESULTS

Southern blot analysis demonstrated that CY17 contained both human chromosome 16 and 22 sequences (Fig. 3.4).

A total of 35 human λ clones were isolated from the unamplified CY17 library, constructed as outlined in Figure 3.5. Each clone was restricted with EcoRI to liberate the insert(s) (Table 3.1).

Filters containing EcoRI digests of the clones were probed with ^{32}P -labelled, nick-translated, pBLUR8 and mouse genomic DNA to determine which fragments contained human and mouse repetitive sequences (Table 3.1). Twelve λ clones (30, 127, 143, 193, 198, 204, 215, 221, 227, 230, 232, and 247) contained restriction fragment(s) that did not hybridize to either probe and may have been nonrepetitive (or low-copy) human or mouse fragments (Table 3.1). These fragments were resolved by probing Southern blot filters, containing both a human and mouse genomic DNA sample restricted with EcoRI with the appropriate clone (Chapter 4). The average human insert was ~8.4 kb and the average mouse insert was ~4.4 kb (Table 3.1). The results of the library screen are summarized in Table 3.2.

3.4 DISCUSSION

Recombinant DNA libraries are usually constructed from either partially digested DNAs or from total digests (Maniatis et al., 1982). The use of partially digested DNAs has the advantage that a suitable size range can be used for cloning, making the maximum use of the cloning capacity of the vector (Williams and Blattner, 1979). The initial aim in the construction of the CY17 library was to clone partially digested EcoRI fragments of 15-20 kb into the vector λ Charon 4A which was ideally suited for the cloning of such fragments (Williams and Blattner, 1979).

FIGURE 3.4

SOUTHERN BLOT ANALYSIS OF CY17 WITH Huap15 AND pA079

Genomic DNA (15 μ g) from mouse (A9), WEGROTH-D2, CY18, CY17 (2.1.8) and a human sample (10 μ g) (lanes 1, 2, 3, 4 and 5 respectively) was restricted with TaqI, electrophoresed in an agarose gel and then Southern blotted. The filter was prehybridized then hybridized with 32 P-labelled, nick-translated Huap15. Huap15 contains a 2.2 kb BamHI fragment derived from the human adenine phosphoribosyltransferase (APRT) gene (Stambrook *et al.*, 1984) which has been mapped to chromosome 16 (Tischfield and Ruddle, 1974). In addition, Huap15 detects a TaqI RFLP (Stambrook *et al.*, 1984) with fragments at either at 2.7 kb (see lane 3) or at 2.1 kb (see lane 4).

The filter was exposed overnight at -70°C and then developed. Huap15 hybridized to CY18 (lane 3), CY17 (lane 4) and human (lane 5) DNAs.

A duplicate filter, as prepared above, was hybridized with 32 P-labelled, nick-translated, pA079. pA079 contains a 1.3 kb BamHI/HindIII restriction fragment derived from the 5' region of the human c-sis oncogene (van den Ouweland *et al.*, 1985) which has been mapped to chromosome 22 (Dalla Favera *et al.*, 1982).

The filter was exposed overnight at -70°C and then developed. pA079 hybridized to WEGROTH-D2 (lane 2), CY17 (lane 4) and human (lane 5) DNAs.

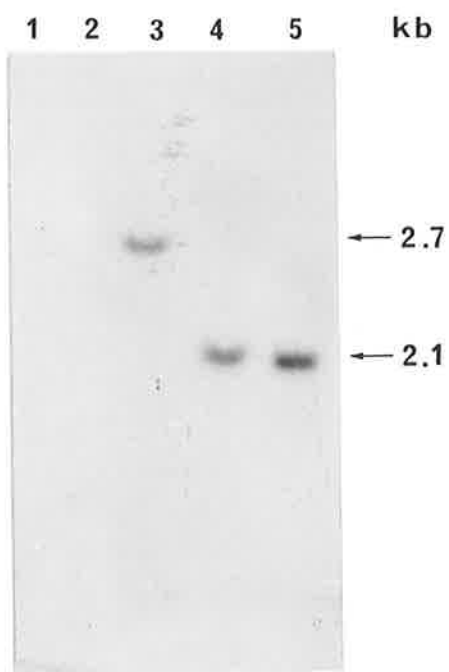

Huap15

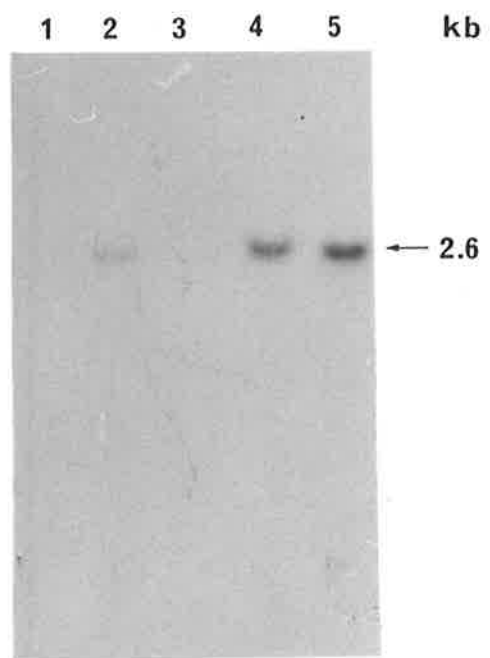

pAO79

FIGURE 3.5

SUMMARY OF LIBRARY CONSTRUCTION AND SCREENING

ISOLATION OF HIGH MOLECULAR WEIGHT GENOMIC DNA FROM CY17

|

COMPLETE RESTRICTION WITH EcoRI

|

LIGATION INTO λ CHARON 4A EcoRI ARMS

|

IN VITRO ENCAPSULATION WITH PACKAGENE

|

PLATE OUT LIBRARY ON E.coli LE392

|

TRANSFER PLAQUES ONTO GENESCREEN MEMBRANES

|

PROBE FILTERS WITH ³²P-LABELLED, NICK-TRANSLATED, pBLUR8

|

ISOLATE POSITIVE λ CLONES

|

SECOND AND THIRD SCREEN WITH pBLUR8

|

DNA PREPARATIONS FROM CLONES AND RESTRICTIONS WITH EcoRI

|

NUMBER AND SIZE OF THE INSERT(S)

|

PROBE DIGESTS WITH ³²P-LABELLED pBLUR8 AND TOTAL MOUSE GENOMIC DNA

TABLE 3.1

SUMMARY OF THE THIRTY FIVE CLONES
THAT WERE ISOLATED

λ	NO. OF INSERTS	SIZE (KB) OF <u>EcoRI</u> FRAGMENTS	
		<u>HUMAN</u> ^a	<u>MOUSE</u> ^b
6	3	5.0	<u>9.5</u> , <u>6.0</u>
30	2	9.5	<u>2.5</u>
43	2	10.5	<u>6.2</u>
45	3	3.1	<u>9.0</u> , <u>2.3</u>
64	1	12.0	-
65	3	1.8	<u>6.2</u> , <u>1.9</u>
71	2	9.0	<u>5.7</u>
72	2	10.0	<u>2.8</u>
73	1	19.0	-
76	3	4.3	<u>11.0</u> , <u>6.5</u>
93	2	6.0	<u>4.7</u>
119	3	6.8	<u>5.7</u> , <u>4.7</u>
127	2	11.0	<u>2.0</u>
141	3	6.5	<u>4.0</u> , <u>1.5</u>
143	2	9.0	<u>3.0</u>
162	2	17.0	<u>1.0</u>
171	2	8.5	<u>6.5</u>
175	2	6.5	<u>8.0</u>
193	2	10.0	<u>2.0</u>
198	2	5.9	<u>4.8</u>
204	2	5.0	<u>4.8</u>
206	3	4.6	<u>3.4</u> , <u>2.7</u>
214	2	3.4	<u>8.0</u>
215	3	3.4	<u>6.5</u> , <u>4.6</u>
221	2	12.5	<u>3.2</u>
227	2	8.5	<u>2.7</u>
230	2	12.0	<u>2.0</u>
232	2	6.0	<u>3.6</u>
236	3	9.0	<u>6.0</u> , <u>2.0</u>
245	2	11.0	<u>4.0</u>
247	3	8.3	<u>4.6</u> , <u>2.1</u>
249	1	15.0	-
255	1	11.0	-
266	2	7.0	<u>4.5</u>
267	3	4.5	<u>7.0</u> , <u>1.0</u>

^aRestriction fragments that hybridized with ³²P-labelled, nick-translated, pBLUR8.

^bRestriction fragments that hybridized with ³²P-labelled, nick-translated, total mouse genomic DNA are underlined.

TABLE 3.2

SUMMARY OF SCREENING RESULTS FROM THE CY17 LIBRARY

	TOTAL	%
Total clones plated out	26,000	100
Clones selected on first screen	54/26,000	0.2
Clones retained on second screen	40/54	74
Clones retained on third screen	35/40	88
Total human clones from library	35/26,000	0.14
Clones with single insert	4/35	11
Clones with two inserts	20/35	57
Clones with three inserts	11/35	32
Clones with mouse repeats	18/35	51

Despite many repeated attempts to set up suitable partial digest conditions, as outlined in Maniatis et al. (1982), the CY17 DNA did not give a good fragment size range (15-20 kb). The DNA was usually >20 kb, hence a majority of the fragments would not have been cloned (Williams and Blattner, 1979). The CY17 DNA was re-extracted with phenol-chloroform, re-dialysed and re-ethanol precipitated, in the event that contaminants were inhibiting the activity of the restriction enzyme. Despite these cleaning up steps, the DNA still gave insufficiently digested DNA of the correct size range. In all cases fresh reagents and enzymes were used. A control human genomic DNA sample consistently produced the correct partial DNA size range, using the same reagents. Conditions were established however that resulted in the complete digestion of the CY17 genomic DNA. Cloning total digested DNA is less than ideal since many fragments would be above and below the cloning capacity of the vector.

Eighty nine percent of the clones had two or more inserts (Table 3.2). In hindsight, this could have been prevented by initially de-phosphorylating the EcoRI CY17 genomic DNA fragments (Maniatis et al., 1982).

Fortunately, this turned out not to be such a problem (Chapter 4) since (1) no clone contained two or more human inserts, presenting no ambiguities in the mapping of the clones, (2) none of the clones had mouse inserts that cross-hybridized with human genomic DNA, hence presenting no problems for mapping or for the search for RFLPs, (3) clones containing mouse repetitive inserts could still be used in hybridization experiments, since these clones were pre-reassociated with shDNA and smDNA in the same reaction and (4) clones that failed to give interpretable autoradiographs were due to the presence of excess repetitive sequences in the human restriction fragments.

The percentage of human clones isolated from the library was quite low, at 0.14 percent (Table 3.2), compared with 0.25 percent obtained by Gusella et al. (1980), ~1.0 percent obtained by Porteous et al. (1986) and Wasmuth et al. (1986) and 5.0 percent obtained by Cavenee et al. (1984). The percentage of human clones obtained from hybrid cell libraries is dependent on both the number and size of the human chromosomes present. The cell line CY17 did not have a human chromosome in every cell, hence the overall ratio of human chromosomes to rodent chromosomes was quite low. The chromosomes 16 and 22 were also smaller in size than most of the autosomes. In addition, cell lines differ tremendously in their ability to retain human chromosomes. It was possible that the growing up of the cell line in tissue culture could have resulted in further loss of human chromosomes (Callen, personal communication). In addition, not having obtained size selected and phosphatased EcoRI CY17 DNA fragments, would have resulted in a decrease in the number of clonable fragments.

Using pBLUR8 would isolate, from the library, those sequences homologous to the cloned Alu repeat (Jelinek et al., 1980). The Alu sequences are present in about 300,000 copies per haploid genome, which is equivalent to one Alu sequence per 10 kb of DNA (Jelinek et al., 1980). Of 100 randomly selected clones from a genomic library containing 15-20 kb human inserts, probed with Alu DNA sequences, 94 were positive indicating the ubiquitous nature of the Alu repeat (Jelinek and Schmid, 1982). In conclusion, pBLUR8 would have been quite efficient in the detection of human clones from the CY17 library.

3.5 SUMMARY

Southern blot analysis confirmed the presence of chromosome 16 and 22 sequences in CY17. A total of 35 plaque purified human λ clones

(0.14%) were isolated from the unamplified CY17 library ($\sim 2.6 \times 10^4$ pfu) after screening with pBLUR8. Of the λ clones, four contained a single human insert, 20 had two inserts (one human and one mouse) and 11 had three inserts (one human and two mouse). Eighteen λ clones had mouse inserts that contained repetitive sequences. The average human insert was ~ 8.4 kb in size and the average mouse insert was ~ 4.4 kb in size. The λ clones were used for mapping onto chromosome 16 or 22 (Chapter 4) as well as for searching for RFLPs (Chapter 5).

CHAPTER 4

PHYSICAL MAPPING OF CLONES FROM THE CY17 RECOMBINANT LIBRARY

4.1 INTRODUCTION

Anonymous DNAs isolated from various libraries (1.4.4), that detect RFLPs, have been regionally mapped to specific human chromosomes by the use of either somatic cell hybrid panels (Carlock *et al.*, 1985; Cavenee *et al.*, 1984; Gusella *et al.*, 1980; Hyland *et al.*, 1988a) or by *in situ* hybridization (Buroker *et al.*, 1987a, 1987b; Callen *et al.*, 1988a, 1988b).

A mouse-human hybrid cell panel of chromosome 16 (Table 2.2) was constructed by Callen (1986) to localize cloned genes and anonymous DNAs to specific intervals of chromosome 16.

This chapter details the mapping of the λ clones isolated from the CY17 library (Chapter 3). The λ clones were initially assigned to human chromosome 16 or 22 since CY17 contained both chromosomes 16 and 22 in approximately a 2:1 ratio (Deisseroth *et al.*, 1977). Twelve λ clones had restriction fragment(s) that did not hybridize to either pBLUR8 or total mouse genomic DNA (Table 3.1). The restriction fragments may have been unique human or mouse DNAs. The use of *EcoRI* mapping panels (4.2.1) resolved these fragments as being either human or mouse (Table 3.1).

Clones assigned to chromosome 16 were then regionally localized to specific segments of chromosome 16 by the use of the hybrid cell panel. Some of these clones were further localized by *in situ* hybridization.

4.2 METHODS

4.2.1 INITIAL MAPPING OF CLONES ONTO CHROMOSOMES 16 AND 22

The λ clones were ³²P-labelled by nick-translation (2.2.12.1) and pre-reassociated (2.2.13) with shDNA, or with shDNA and smDNA (if the clone had a mouse repetitive fragment, see Table 3.1), in the same reaction mix. The pre-reassociated clones were hybridized (2.2.14) to Southern blot filters (2.2.11) containing the following DNAs (15 μ g),

restricted with either EcoRI or TaqI: mouse (A9), WEGROTH-D2, CY17, CY18 (Table 2.1) and two random human genomic DNAs (10 µg).

4.2.2 REGIONAL MAPPING OF CHROMOSOME 16 CLONES

Clones that were initially mapped to chromosome 16 were further localized to specific intervals of chromosome 16 by hybridizing the ³²P-labelled, pre-reassociated clones to Southern blot filters containing the following DNAs (15 µg) restricted with either EcoRI or TaqI: A9, CY18, CY14, CY13, CY11, CY8, CY7, CY6, CY5, CY3, CY2 (Table 2.1) and a human genomic DNA (10 µg).

For clones λ141, 175 and λ206, 10 µg of EcoRI restricted DNA was electrophoresed in a 0.7% low gelling temperature agarose gel (2.1.3) and the corresponding human insert band was isolated (2.2.10). The isolated human insert (40 ng) was ³²P-labelled by oligo-labelling (2.2.12.2), pre-reassociated with shDNA (2.2.13) and hybridized to Southern blot filters as described above.

4.2.3 IN-SITU HYBRIDIZATION OF CHROMOSOME 16 CLONES

As part of a larger group study aimed at the mapping of chromosome 16, several of the chromosome 16 clones isolated from the CY17 library were localized with respect to the fragile sites FRA16A and FRA16B (1.5.7) by in situ hybridization. The following clones were used for the experiments: λ64, 215, 221, 227, 230 and λ247 (Table 4.2) which were all done by E. Baker and Dr. D. Callen. These localizations are presented in Callen et al. (1988a, 1988b) and in Figure 4.4.

4.3 RESULTS

Clones were mapped to chromosome 16 if hybridizing fragments of similar molecular weight were detected in CY17, CY18, and human DNAs,

and to chromosome 22 if CY18 did not hybridize and WEGROTH-D2 did. Clones that did not hybridize to either CY18 and WEGROTH-D2 did not map to either chromosome 16 or 22. Clones that consistently gave excessively high lane backgrounds in tracks with human DNA could not be mapped. Examples of clones mapping to chromosome 16, 22 and to neither are shown in Figure 4.1. The initial mapping results of the clones are summarized in Table 4.1 and both the number and size of the insert(s) for the chromosome 16 clones are summarized in Table 4.2. The regional locations of the chromosomal 16 clones are summarized in Table 4.3 and shown with respect to the breakpoints in the hybrids and the fragile sites in Figure 4.4.

The clones were registered with the Yale Human Gene Mapping Library registry and the appropriate D numbers were assigned to them (Table 4.3). Examples of mapping results are shown in Figures 4.2 and 4.3. One clone was mapped to the interval 16pter→16p13.11, two clones were mapped to 16p13.3→16p13.11, one clone was mapped to 16p13.11→16q13, three clones were mapped to 16q13→16q22.1 and one clone was mapped to 16q22.1→16q24 (Table 4.3). No clones were obtained that mapped from 16pter→16p13.3 or from 16q24→16qter.

Clones λ93, 141, 175, 206 and λ232 were initially mapped to chromosome 16 (Table 4.1). All these clones produced relatively high human lane backgrounds, although a corresponding human hybridizing fragment could be visualized in the CY18 lane with the use of a lightbox. Isolating the human insert from clones λ141, 175 and λ206 and probing Southern blot filters containing DNAs from the hybrid cell panel did not produce autoradiographs of good enough quality to allow a definitive localization. The human inserts from clones λ93 and λ232 were not isolated since both clones gave very low yields of DNA despite repeated attempts at isolating DNA from them.

FIGURE 4.1

EXAMPLES OF λ CLONES, ISOLATED FROM THE CY17 LIBRARY, MAPPING TO
CHROMOSOME 16, 22 AND TO NEITHER

Clones λ 221, λ 73 and λ 204 were ^{32}P -labelled by nick-translation and pre-reassociated with shDNA. The pre-reassociated clones were hybridized to Southern blot filters containing the following DNAs (15 μg), restricted with TaqI: mouse (A9), WEGROTH-D2, CY17, CY18 (Table 2.1) and a human genomic DNA (10 μg). The washed filters were exposed overnight at -70°C and then developed.

(A) λ 221 produced human hybridizing fragments in CY17 and CY18, but not in WEGROTH-D2, and hence mapped to chromosome 16.

(B) λ 73 produced human hybridizing fragments in CY17 and WEGROTH-D2, but not in CY18, and hence mapped to chromosome 22.

(C) λ 204 produced human hybridizing fragments in CY17 only, hence the clone did not map to either chromosome 16 or 22.

The mapping results of all the clones that were isolated from the CY17 library are summarized in Table 4.1.

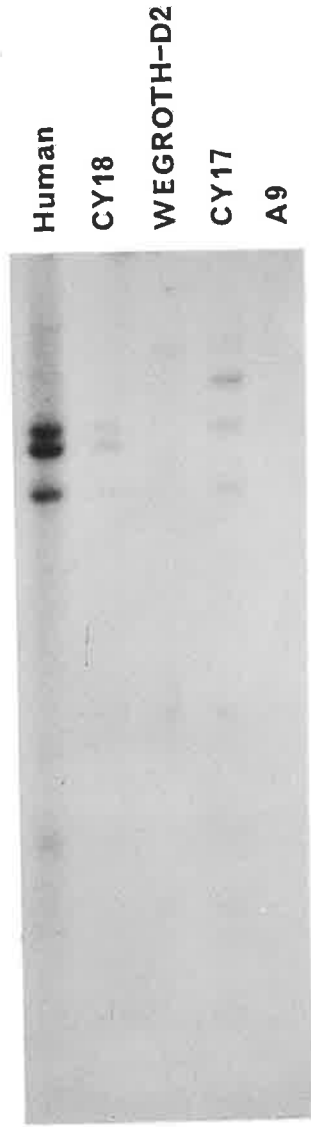

Chromosome 16

(A)

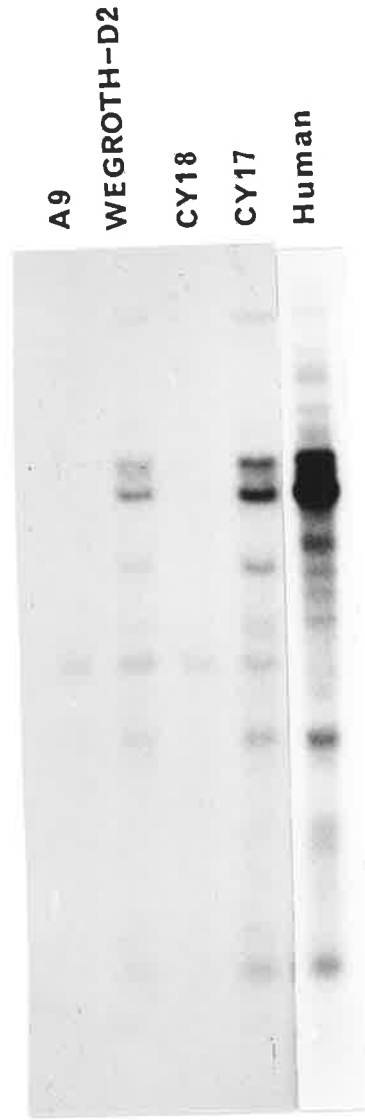

Chromosome 22

(B)

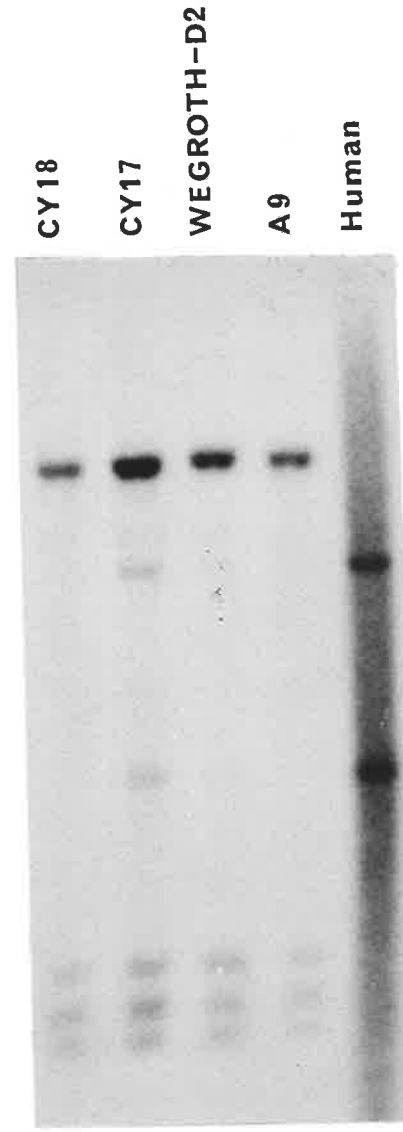

Neither

(C)

TABLE 4.1

MAPPING RESULTS OF CLONES FROM THE CY17 LIBRARY

CHROMOSOME			
16	22	NEITHER ^a	NO RESULT ^b
64	43	30	6
76	45	143	65
93	71	171	214
141	72	193	236
162	73	204	245
175	119	267	266
206	127		
215	198		
221	249		
227	255		
230			
232			
247			
N	13	10	6
%	37	29	17

^aHuman hybridizing fragments were not detected in CY18 and WEGROTH-D2 DNAs.

^bClones consistently gave high human lane backgrounds on Southern blots, despite pre-reassociation with shDNA and smDNA.

TABLE 4.2

CLONES THAT MAPPED TO CHROMOSOME 16

λ	NO. OF INSERTS	SIZE (KB) OF <u>EcoRI</u> FRAGMENTS	
		<u>HUMAN</u> ^a	<u>MOUSE</u> ^b
64	1	12.0	-
76	3	4.3	11.0, <u>6.5</u>
93	2	6.0	<u>4.7</u>
141	3	6.5	<u>4.0</u> , <u>1.5</u>
162	2	17.0	<u>1.0</u>
175	2	6.5	<u>8.0</u>
206	3	4.6	<u>3.4</u> , <u>2.7</u>
215	3	3.4	6.5, 4.6
221	2	12.5	3.2
227	2	8.5	2.7
230	2	12.0	2.0
232	2	6.0	3.6
247	3	8.3	4.6, 2.1

^aRestriction fragments that hybridized with ³²P-labelled, nick-translated, pBLUR8.

^bRestriction fragments that hybridized with ³²P-labelled, nick-translated, total mouse genomic DNA are underlined.

FIGURE 4.2

REGIONAL MAPPING OF λ 247 (D16S8) ON CHROMOSOME 16

λ 247 (D16S8) was ^{32}P -labelled by nick-translation and pre-reassociated with shDNA. The pre-reassociated clone was hybridized to a Southern blot filter containing the following DNAs (15 μg) restricted with EcoRI: WEGROTH-D2, A9, CY18, CY17, CY14, CY13, CY11, CY7, CY5, CY3, CY2 (Table 2.1) and a human genomic DNA (10 μg). The washed filter was exposed for seven days at -70°C and then developed.

λ 247 produced a human hybridizing fragment of 8.3 kb in CY18, CY17, CY14 and CY3. This implied that λ 247 mapped from 16p13.3- \rightarrow p13.11 (Table 4.3).

The two mouse inserts in λ 247 hybridized at 4.6 and 2.1 kb.

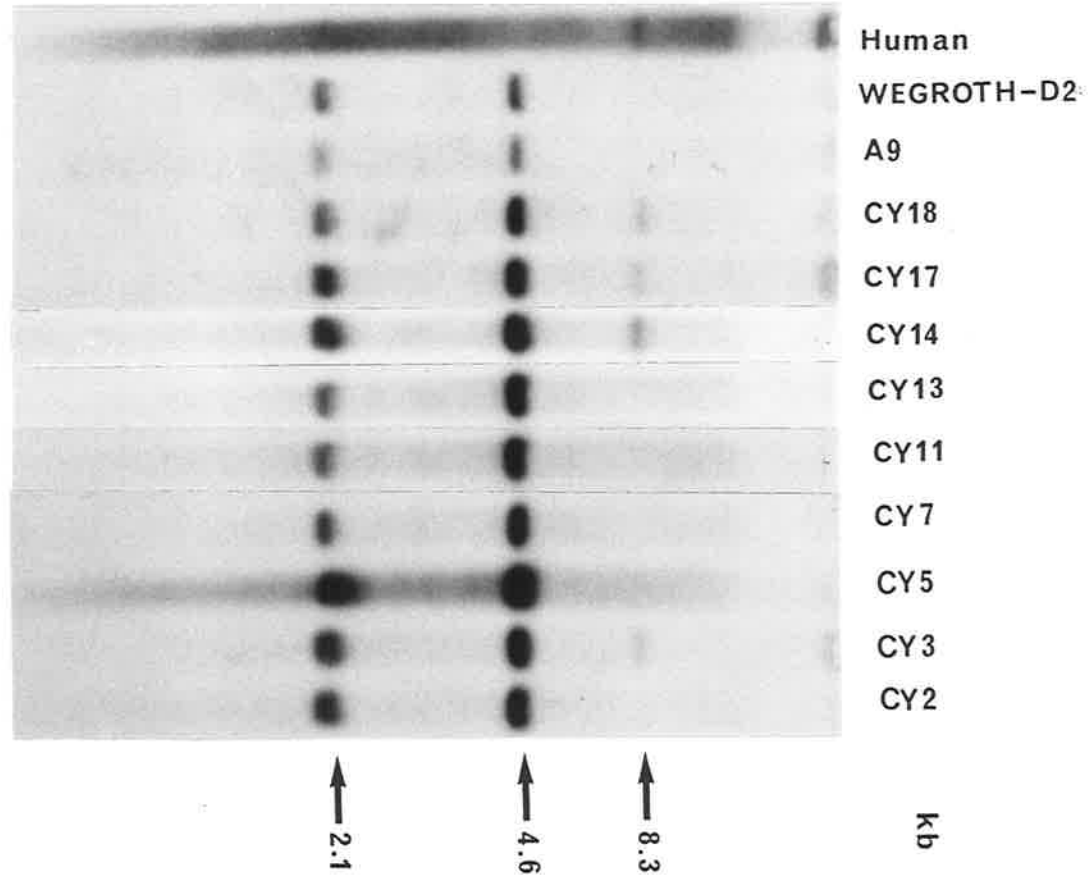

FIGURE 4.3

REGIONAL MAPPING OF λ 221 (D16S10) ON CHROMOSOME 16

λ 221 (D16S10) was ^{32}P -labelled by nick-translation and pre-reassociated with shDNA. The pre-reassociated clone was hybridized to a Southern blot filter containing the following DNAs (15 μg) restricted with TaqI: WEGROTH-D2, A9, CY18, CY17, CY13, CY11, CY7, CY5, CY3, CY2 (Table 2.1) and a human genomic DNA (10 μg). The washed filter was exposed for three days at -70°C and then developed. The human lane was from an overnight exposure of the filter.

λ 221 produced human hybridizing fragments of 5.4, 4.5, 4.1 and 3.4 kb in CY18, CY17, CY13, CY11, CY7 and CY3. This implied that λ 221 mapped from 16q13- \rightarrow q22.1 (Table 4.3).

The mouse insert in λ 221 hybridized at 1.5 kb.

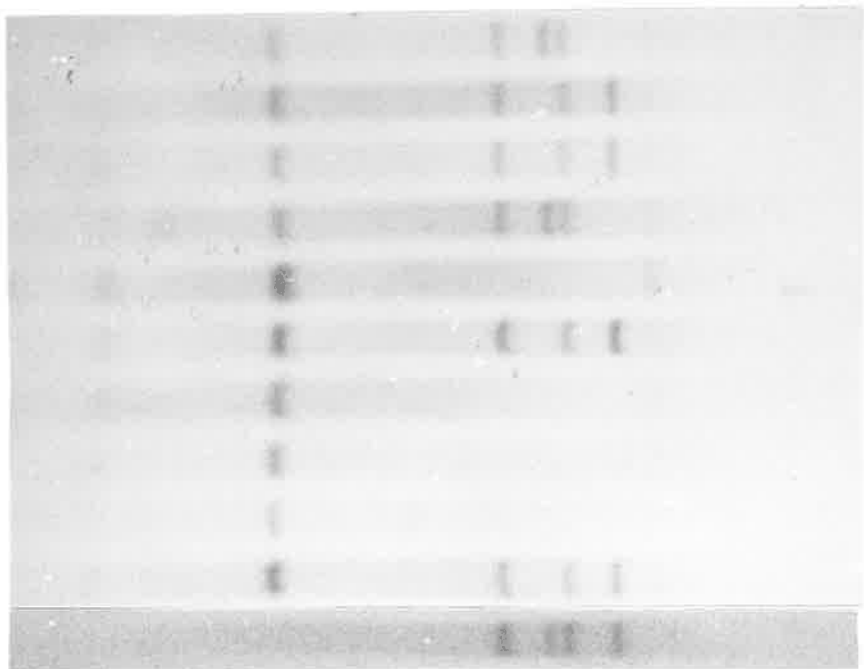

CY18
CY13
CY11
CY7
CY5
CY3
CY2
A9
WEGROTH-D2
CY17
Human

↑ 1.5
↑ 3.4
↑ 4.1
↑ 4.5
↑ 5.4

Kb

TABLE 4.3

REGIONAL MAPPING OF CHROMOSOME 16 CLONES

λ	D No.	INSERT ^a SIZE (KB)	HYBRIDIZATION TO DNA IN CELL LINES												LOCATION ON CHROMOSOME 16
			A9	HUMAN	CY18	CY14	CY13	CY11	CY8	CY7	CY6	CY5	CY3	CY2	
215	<u>16S9</u>	3.4	-	+	+	ND ^b	-	-	NA ^c	-	NA	-	+	-	16pter-→p13.11
247	<u>16S8</u>	8.3	-	+	+	+	-	-	NA	-	NA	-	+	-	16p13.3-→p13.11
76	<u>16S114</u>	4.3	-	+	+	+	-	-	NA	-	NA	-	+	-	16p13.3-→p13.11
162	<u>16S115</u>	17.0	-	+	+	+	+	+	-	-	-	-	+	-	16p13.11-→q13
64	<u>16S113</u>	12.0	-	+	+	NA	+	+	+	+	-	-	+	-	16q13-→q22.1
221	<u>16S10</u>	12.5	-	+	+	NA	+	+	NA	+	-	-	+	-	16q13-→q22.1
227	<u>16S11</u>	8.5	-	+	+	NA	+	+	NA	+	-	-	+	-	16q13-→q22.1
230	<u>16S12</u>	12.0	-	+	+	NA	+	+	NA	+	NA	+	+	-	16q22.1-→q24

^aTo simplify the presentation of the table, only the hybridization pattern of the human insert is shown.

^bNot determined, indicating that the hybrid cell line was not available at the time. In situ hybridization with λ 215 (4.2.3) precluded the clone from the 16pter-→p13.3 region (Callen, personal communication).

^cNot applicable, the use of the hybrid cell line would not have altered the clone's localization.

FIGURE 4.4

REGIONAL LOCALIZATION OF CHROMOSOME 16 CLONES

The regional localizations of λ 247 (16S8), λ 215 (16S9), λ 221 (16S10), λ 227 (16S11), λ 230 (16S12), λ 64 (16S113), λ 76 (16S114) and λ 162 (16S115) are shown in respect to the breakpoints of the chromosome 16 in the hybrid cell lines (identified by a specific CY number; see Figure 2.1 and Table 2.2) and the four fragile sites FRA16A, FRA16B, FRA16C and FRA16D. In addition, the new location for the APRT gene is shown.

λ 247 (16S8) and λ 215 (16S9) were further localized by in situ hybridization as distal to FRA16A, λ 221 (16S10) and λ 227 (16S11) as proximal to FRA16B and λ 230 (16S12) and λ 64 (16S113) as distal to FRA16B (4.2.3).

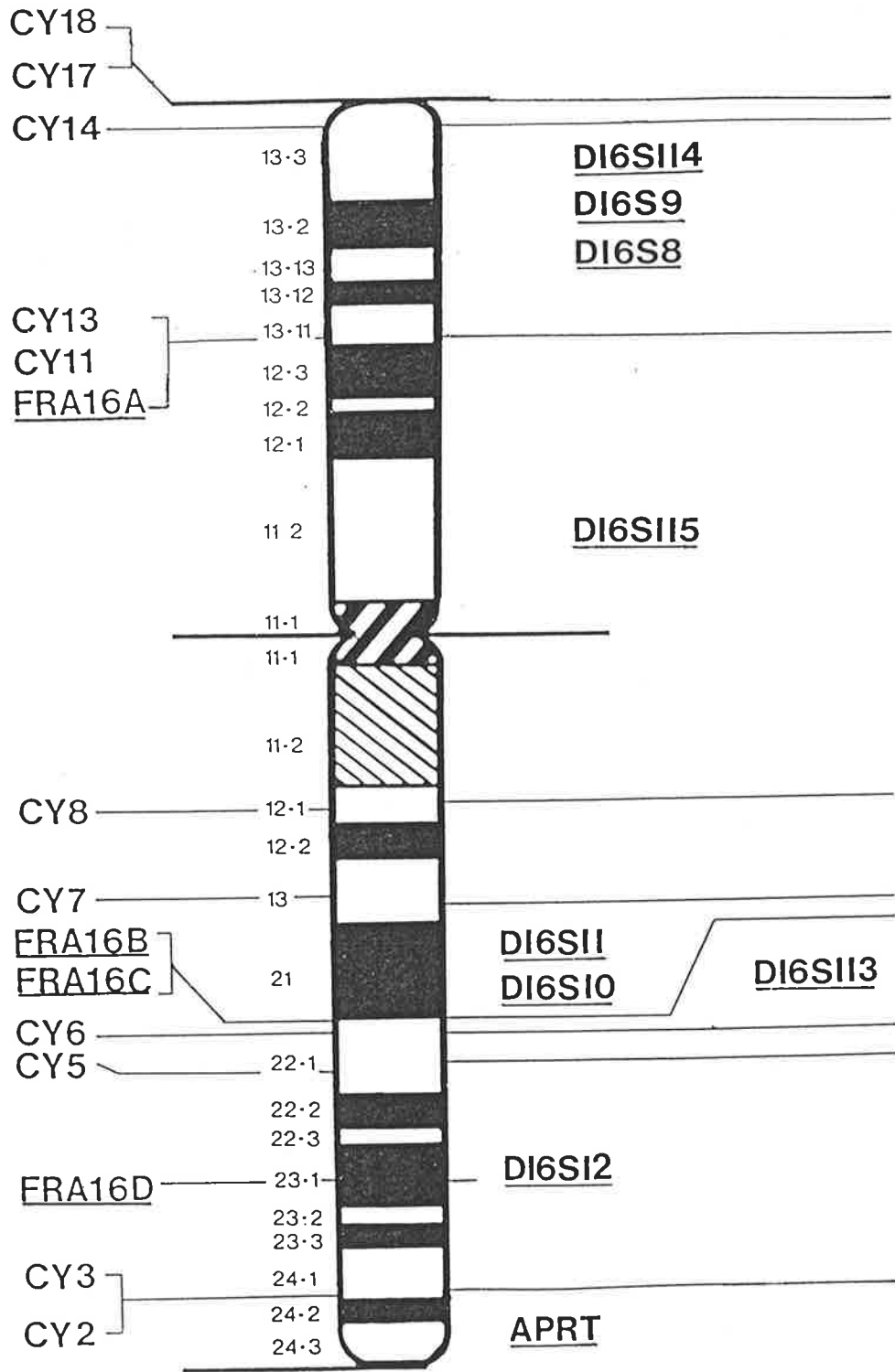

4.4 DISCUSSION

4.4.1 CLONES FROM THE CY17 LIBRARY

Of the 35 human clones isolated from the CY17 library, 13 mapped to chromosome 16, 10 mapped to chromosome 22, six to neither chromosome and six gave uninterpretable autoradiographs (Table 4.1). One of the chromosome 22 clones, ACHF249 (D22S14), detected a PstI RFLP (Fratini et al., 1988a). No further analysis was done on the remaining chromosome 22 clones or the clones that did not map to either chromosome 16 or 22. Eight of the 13 clones that mapped to chromosome 16 were regionally localized on chromosome 16 by the use of a somatic cell hybrid panel (Table 4.3).

Six clones did not map to either chromosome 16 or 22, indicating that the original cell line CY17 (WAIVA) contained human chromosomal fragments that were not detected by karyotype analysis (Deisseroth et al., 1977). CY17 may have had segments of human chromosomal fragments that were translocated onto the mouse chromosomes. Evidence of this was shown by in situ hybridization of ³H-labelled pBLUR8 to metaphase preparations of CY17 (Callen, personal communication). The results showed the hybridization of pBLUR8 to a human chromosome, presumably chromosome 16, as well as hybridization to the terminal end of a mouse chromosome. This may represent human chromosomal material that had been translocated on the end of one of the mouse chromosomes. These findings suggest a possible explanation for the clones that did not map to either chromosomes 16 or 22. Definitive proof would require mapping of one of these clones.

Six clones (17%) gave uninterpretable autoradiographs, which were most probably due to the presence of highly repetitive sequences in the human DNA fragments. Longer pre-reassociation times did not help in reducing the lane backgrounds. These clones hybridized as smears to the

human DNAs samples. It was most likely that these clones were mainly composed of repetitive sequences. From a study of nearly 600 clones, Barker *et al.* (1985) found that 30 percent of pre-reassociated clones gave uninterpretable autoradiographs.

Polymorphic clones mapping to the region 16pter-→16p13.11 are of potential interest for linkage analysis with the fragile site FRA16A (Callen *et al.*, 1988b) and those mapping to 16q13-→16q22.1 are of potential interest for linkage analysis with FRA16B (Callen *et al.*, 1988a, Mulley *et al.*, 1988). λ 215 and λ 247 were mapped distal to FRA16A, by *in situ* hybridization (4.2.3), λ 221 and λ 227 mapped proximal to FRA16B and λ 64 and λ 230 mapped distal to FRA16B (Fig. 4.3). All six clones were in potentially interesting locations with respect to FRA16A and FRA16B.

The CY17 recombinant library contained a relatively low percentage of chromosome 16 derived clones. This was in part due to the addition of chromosome 22 and the additional human chromosomal material in CY17. Forty six percent of the clones were not from chromosome 16. However, the chromosome 16 clones that were obtained had reasonable inserts, the average being ~8.4 kb, and they mapped to separate regions of chromosome 16. Six of these clones were localized with respect to FRA16A and FRA16B by *in situ* hybridization. All six were potentially useful for possible linkage analysis studies, if they were polymorphic (Chapter 5), with the corresponding fragile sites.

At about the time the clones from the CY17 library were being characterized, a FACS-purified human chromosome 16 library was obtained from the Lawrence Livermore National Laboratory. This library was characterized by other members of the research group. Of the 69 clones isolated from the library, 29 contained inserts of > 500 bp of which only six of the 18 that were analyzed mapped to chromosome 16 (Hyland

et al., 1988a). Since the clones contained relatively small inserts and the purity of the library for chromosome 16 was not as high as expected, the use of the library was discontinued. Since then, a genomic library was constructed from the hybrid cell line CY3 (Table 2.1), in order to isolate anonymous DNAs to chromosomes 16 and X (Hyland et al., 1989) and is at present being extensively characterized. Additional chromosome 16 libraries, both in λ and cosmid vectors, have been constructed by other investigators for the isolation of anonymous DNAs (Breuning et al., 1988; Bufton et al., 1986; Harris et al., 1987; Liu et al., 1987).

4.4.2 REMAPPING OF HUMAN ADENINE PHOSPHORIBOSYLTRANSFERASE

During the construction of the hybrid cell panel for chromosome 16, many of the DNAs from the cell lines were hybridized with probes from chromosome 16 in order to characterize the lines (Callen, 1986). As a consequence, use of the hybrid cell panel allowed the remapping of the gene for adenine phosphoribosyltransferase (APRT) (Fratini et al., 1986). The reassignment of APRT to 16q24 (Fig. 4.4), which had been previously assigned to 16q22.2- \rightarrow q22.3 (HGM7, 1984), resolved an inconsistency in the localization of APRT by several groups (HGM7, 1984). The result explained the reported absence of linkage between APRT and haptoglobin (HP) (Castiglione et al., 1985), despite both loci having been mapped within band 16q22 (HGM7, 1984) and the absence of linkage between FRA16B and APRT (Mulley, personal communication).

Simmers et al. (1987a) showed that metallothionein (MT) was proximal to FRA16B. The HP locus was distal to FRA16B (Simmers et al., 1986). With the mapping of APRT distal to HP and FRA16D (Fratini et al., 1986), The loci could be ordered with respect to FRA16B and FRA16D as: cen-MT-FRA16B-HP-FRA16D-APRT-qter. This provided a group of ordered loci in which anonymous DNAs from the CY17 and the FACS-purified library, as

well as other cloned genes from chromosome 16, could be mapped with respect to these loci by linkage analysis (Mulley et al., 1988) and by in situ hybridization (Callen et al., 1988a, 1988b).

4.5 SUMMARY

Of the 35 human clones isolated from the CY17 library, 13 mapped to chromosome 16, 10 mapped to chromosome 22, six to neither chromosome and six gave uninterpretable autoradiographs. Eight of the 13 clones that mapped to chromosome 16 were regionally localized on chromosome 16. One clone mapped to the interval 16pter->16p13.11, two clones mapped to 16p13.3->16p13.11, one clone mapped to 16p13.11->16q13, three clones mapped to 16q13->16q22.1 and one clone mapped to 16q22.1->16q24.

The human gene for adenine phosphoribosyltransferase (APRT) was re-mapped from 16q22.2->q22.3 to 16q24.

CHAPTER 5

SEARCH FOR RFLPS WITH THE CHROMOSOME 16 CLONES

5.1 INTRODUCTION

This chapter details the search of RFLPs with the mapped chromosome 16 clones (Chapter 4), following the strategy outlined in Skolnick and White (1982). Preference was given to the clones that were localized in the vicinity of FRA16A and FRA16B (Fig. 4.4). Clones that detected RFLPs were subcloned into suitable plasmid vectors.

5.2 METHODS

5.2.1 SEARCH FOR RFLPS

Genomic DNAs (10 µg) from six unrelated individuals was prepared (2.2.4.1) and digested with the following restriction endonucleases: BamHI, BanII, BclI, BglI, BglII, BstNI, EcoRI, EcoRV, HincII, HindIII, HinfI, MspI, PstI, PvuII, RsaI and TaqI (2.2.8). The restricted DNAs were electrophoresed in 0.8% agarose gels (2.2.9) in 1xTBE buffer (2.1.3) and Southern blotted (2.2.11). The filters were prehybridized then hybridized (2.2.14) with the ³²P-labelled, nick-translated (2.2.12.1), pre-reassociated λ clones (2.2.13).

5.2.2 MENDELIAN INHERITANCE AND ALLELE FREQUENCIES OF RFLPS

The Mendelian inheritance of RFLPs was shown by probing Southern blot filters containing the DNA (10 µg) from informative Utah families (2.1.9) digested with the appropriate restriction endonuclease. The allele frequency of RFLPs was determined by probing Southern blot filters containing genomic DNA (10 µg) from 15-26 random human DNAs, digested with the appropriate enzyme.

5.2.3 SUBCLONING OF CLONES DETECTING RFLPS

5.2.3.1 SUBCLONING λ247 (D16S8)

The human insert from λ247 (D16S8) (Table 4.2) was subcloned into

the plasmid vector pUC18 by Dr. S. Reeders as part of using the clone for linkage studies with PKD1 (Reeders, personal communication). This subclone, named pACHF1, was used for further subcloning.

Two hundred nanograms of pACHF1 was restricted with HindIII, XbaI, HindIII/XbaI, EcoRI/XbaI, EcoRI/HindIII/XbaI and EcoRI/HindIII and electrophoresed in a 0.8% agarose gel in 1xTAE. The gel was blotted onto a GeneScreen Plus nylon membrane and the filter was prehybridized then hybridized with ³²P-labelled, nick-translated, total human genomic DNA to identify restriction fragments that contained repetitive sequences (Table 5.5). The molecular weights of the fragments in Table 5.5 were calculated using the program DNASIZE (2.2.16). A restriction map of the insert in pACHF1 (Fig. 5.3) was determined using the data derived from Table 5.5.

Two micrograms of pACHF1 was restricted with XbaI and the digest was electrophoresed in a 0.8% agarose gel in 1xTAE. XbaI restriction fragments 1 and 3 (Table 5.5) were cut from the gel and the DNA isolated by GeneClean treatment (2.2.10). The DNA was resuspended in TE buffer (2.1.3) at a final concentration of ~20 ng/μl. XbaI restriction fragment 1 (20 ng) was re-ligated and transformed into competent E.coli MC1061 cells (2.2.15.4). XbaI restriction fragment 3 (20 ng) was ligated (2.2.15.3) into dephosphorylated XbaI-cut pSP64 (2.2.15.1) and then transformed into competent E.coli MC1061 cells.

Individual bacterial colonies were isolated from the plates, re-streaked onto L-amp plates (2.1.4) and mini plasmid DNA preps were made (2.2.6.2). The plasmid DNAs (0.5 μg) were restricted with XbaI and electrophoresed in 0.8% agarose gels to determine if they contained an insert (2.2.15.5).

Both subclones, pACHF1.1 and pACHF1.3 (Fig. 5.3), were used to probe filters containing human genomic DNAs digested with PvuII to

determine if they detected the RFLP.

5.2.3.2 SUBCLONING λ 221 (D16S10)

Ten micrograms of λ 221 (D16S10) DNA was restricted with EcoRI in a final volume of 100 μ l. The digestion mix was Geneclean treated and the DNA was resuspended in TE buffer at a final concentration of ~200 ng/ μ l. Two microliters of the sample was restricted with HindIII, SalI and XbaI in a final volume of 10 μ l. These enzymes were chosen since they infrequently cut λ DNA (Williams and Blattner, 1979). The inserts in λ 221 (Table 4.2) were restricted with HindIII and XbaI, but not with SalI. XbaI produced fragments that could be readily isolated (Table 5.4).

Six hundred nanograms of EcoRI-digested λ 221 and 600 ng of uncut λ 221 was restricted with XbaI. The digests were electrophoresed (including an aliquot of λ 221 pre-digested with EcoRI) in a 0.8% agarose gel in 1xTAE and the gel was blotted onto a GeneScreen Plus nylon membrane. The filter was probed with 32 P-labelled, nick-translated, total human genomic DNA to identify restriction fragments that contained repetitive sequences. Three XbaI restriction fragments, that were insert DNAs, did not hybridize to the probe (Table 5.4).

Ten micrograms of λ 221 was restricted with XbaI and the digest was electrophoresed in a 0.8% agarose gel in 1xTAE. XbaI restriction fragments 5 and 6 (Table 5.4) were cut from the gel and the DNA was isolated by Geneclean treatment. The DNA was resuspended in TE buffer at a final concentration of ~20 ng/ μ l.

Both fragments (20 ng) were 32 P-labelled by oligo-labelling (2.2.12.2) and were used to probe filters containing the following RsaI and TaqI digested DNAs: A9, CY17, CY18 and two independent human DNAs. XbaI restriction fragment 5 detected the RsaI and TaqI RFLPs. This

fragment was ligated into dephosphorylated XbaI-cut pSP64 and then transformed into competent E.coli MC1061 cells.

Individual bacterial colonies were restreaked onto L-amp plates and mini plasmid preps were made (2.2.6.2). The plasmid DNAs (0.5 µg) were restricted with XbaI and electrophoresed in 0.8% agarose gels to determine if they contained an insert.

One hundred nanograms of pSP64 and pACHF3.5, the subclone that detected the RFLPs (Table 5.7), was restricted with RsaI, TaqI and RsaI/TaqI in a final volume of 10 µl. The digests were electrophoresed in a 0.8% agarose gel in 1xTAE and then stained with ethidium bromide. From the restriction fragments obtained, a restriction map of pACHF3.5 was determined (Fig. 5.5).

5.3 RESULTS

Six of the eight anonymous DNA probes that mapped to chromosome 16 (Table 4.3) were screened for their ability to detect RFLPs (Table 5.1). Not all the enzymes were tested for each clone (Table 5.1). Each clone, except for λ230 (D16S12), was screened for RFLPs using the restriction endonucleases, BglII, EcoRI, HindIII, MspI, PstI, PvuII, RsaI and TaqI (Table 5.1).

Two clones, λ247 (D16S8) and λ221 (D16S10), detected RFLPs (Table 5.1). λ247 was polymorphic for PvuII and λ221 was polymorphic for RsaI and TaqI (Table 5.1). The RFLPs detected by λ247 and λ221 are shown in Figures 5.1 and 5.2 respectively, and the details of the polymorphisms are presented in Table 5.2. Both clones demonstrated Mendelian Inheritance (5.2.2) (Table 5.3) and Hardy-Weinberg equilibrium (Table 5.4). D16S8 was informative in Utah families 981, 982, 983, 984 and 985. D16S10 was informative in Utah families 981, 984, 985 and 1029. The DNA typing results are presented in Chapter 6.

TABLE 5.1

SEARCH FOR RFLPS WITH REGIONALLY MAPPED CHROMOSOME 16 CLONES

ENZYMES	CLONES					
	λ 64	λ 215	λ 221	λ 227	λ 230	λ 247
<u>Bam</u> HI	? ^a	ND ^b	-	ND	ND	-
<u>Ban</u> II	-	?	-	-	-	-
<u>Bcl</u> I	-	-	-	-	ND	-
<u>Bgl</u> I	-	-	-	-	ND	ND
<u>Bgl</u> III	-	-	-	-	ND	-
<u>Bst</u> NI	?	-	-	-	ND	ND
<u>Eco</u> RI	?	-	-	-	-	-
<u>Hinc</u> II	ND	-	-	-	-	-
<u>Hind</u> III	-	-	-	-	-	-
<u>Hinf</u> I	ND	?	?	-	-	-
<u>Msp</u> I	?	-	-	-	-	-
<u>Pst</u> I	-	-	-	-	ND	-
<u>Pvu</u> II	-	-	-	-	-	+
<u>Rsa</u> I	?	-	+	-	ND	-
<u>Taq</u> I	-	-	+	-	-	-
TOTAL	13	14	23^c	14	8	13

^aIndicates that a definitive result was not obtained due to high lane background.

^bIndicates not tested; - indicates not polymorphic; + indicates enzyme detected an RFLP.

^cIncluding the following non-polymorphic enzymes: BstXI, DraI, EcoRV, HaeIII, NsiI, SacI and XbaI.

FIGURE 5.1

PvuII RFLP IDENTIFIED BY λ 247 (D16S8)

λ 247 (D16S8) was ^{32}P -labelled by nick-translation and pre-reassociated with shDNA. The pre-reassociated clone was hybridized to a Southern blot filter containing 10 unrelated Caucasian genomic DNAs (10 μg) restricted with PvuII. The washed filter was exposed overnight at -70°C and then developed.

λ 247 produced hybridizing fragments of 6.2 (invariant), 3.8 (A1 allele) and 2.2 kb (A2 allele). The genotypes of the samples are as follows: 1 (A1/A2); 2 (A1/A1); 3 (A1/A2); 4 (A1/A2); 5 (A1/A1); 6 (A1/A2); 7 (A1/A2); 8 (A2/A2); 9 (A1/A1); 10 (A1/A2).

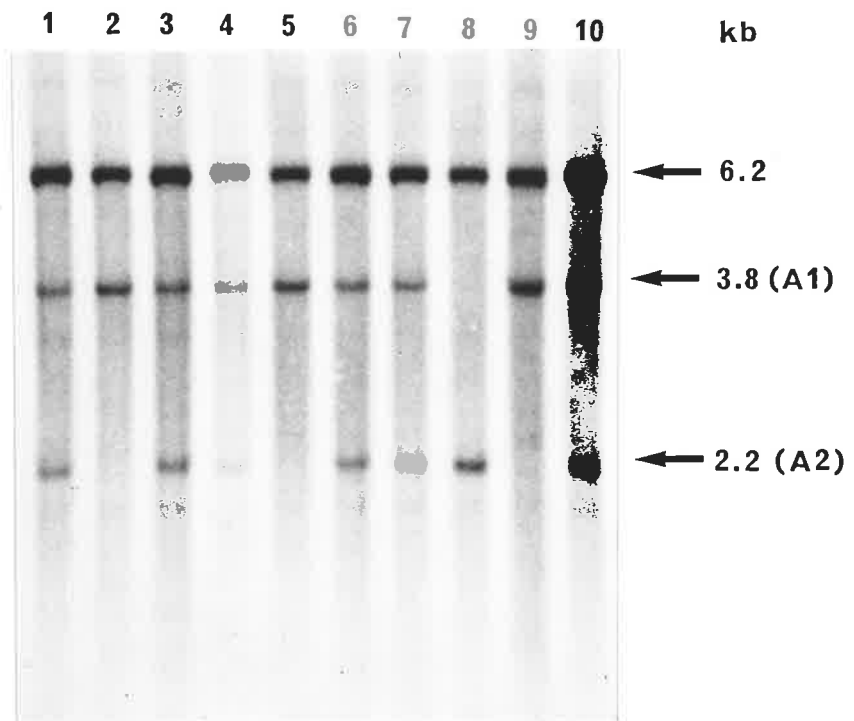

FIGURE 5.2

RsaI AND TaqI RFLPS IDENTIFIED BY λ 221 (D16S10)

λ 221 (D16S10) was ^{32}P -labelled by nick-translation and pre-reassociated with shDNA. The pre-reassociated clone was hybridized to Southern blot filters containing 10 unrelated Caucasian genomic DNAs (10 μg) restricted with either RsaI or TaqI. The washed filters were exposed overnight at -70°C and then developed.

λ 221 produced hybridizing fragments of 2.6 (B1 allele), 1.84 (B2 allele), 1.4 (invariant), 1.2 (invariant), 0.8 (invariant), 0.76 (B2 allele) and 0.6 kb (invariant) on the RsaI filter. The genotypes of the samples were as follows: 1 (B1/B1); 2 (B1/B1); 3 (B1/B1); 4 (B2/B2); 5 (B1/B2); 6 (B1/B2); 7 (B1/B2); 8 (B1/B2); 9 (B1/B2); 10 (B1/B1).

λ 221 produced hybridizing fragments of 6.5 (invariant, very faint), 5.4 (A2 allele), 4.5 (invariant), 4.1 (A1 allele), 3.4 (invariant) and 1.3 kb (A1 allele) on the TaqI filter. The genotypes of the samples were as follows: 1 (A2/A2); 2 (A1/A2); 3 (A1/A2); 4 (A1/A2); 5 (A1/A2); 6 (A1/A1); 7 (A1/A1); 8 (A1/A1); 9 (A1/A2); 10 (A1/A2).

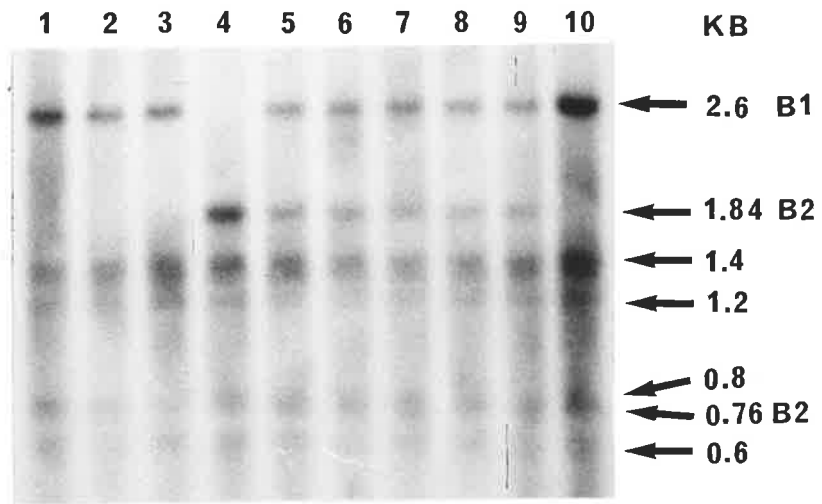

RsaI

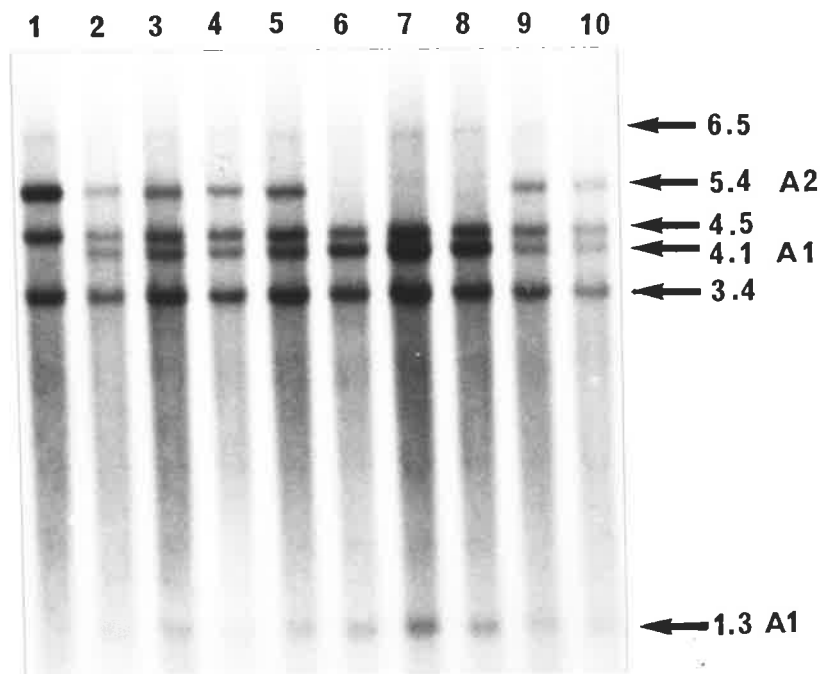

TaqI

TABLE 5.2

RFLP DETAILS FOR λ 247 (D16S8) AND λ 221 (D16S10)

CLONE	ENZYME	CONSTANT BAND(S) SIZE (KB)	POLYMORPHIC BANDS			PIC ^a	SAMPLE SIZE (CHROMOSOMES)
			ALLELE	SIZE (KB)	FREQUENCY		
λ 247	<u>PvuII</u>	6.2	A1	3.80	0.52	0.38	52
			A2	2.20	0.48		52
λ 221	<u>RsaI</u>	1.4	B1	2.60	0.73 ^b	0.32	30
		1.2		1.84			
		0.8	B2		0.76		30
		0.6					
	<u>TaqI</u>	6.5	A1	4.10	0.62	0.36	40
			4.5	1.30			
3.4			A2	5.40	0.38		

^aPIC = $1 - P^2 - Q^2 - 2P^2Q^2$, for a two allele system, with frequencies P and Q (Botstein *et al.*, 1980).

^b Allele frequencies were different for the RsaI and TaqI RFLPs since different human genomic DNAs were used.

TABLE 5.3

DEMONSTRATION OF MENDELIAN INHERITANCE FOR D16S8 AND D16S10^a

D16S8

MATING TYPE	A1A1 x A1A2		A1A2 x A1A2			A1A2 x A2A2	
OFFSPRING	A1A1	A1A2	A1A1	A1A2	A2A2	A1A2	A2A2
OBSERVED	7	7	6	6	7	10	6
EXPECTED	7	7	4.25	9.5	4.25	8	8
χ^2 value ^b	0.0		3.8 ^c			0.4	

D16S10

MATING TYPE	A1A1 x A1A2		A1A2 x A1A2		
OFFSPRING	A1A1	A1A2	A1A1	A1A2	A2A2
OBSERVED	16	10	4	10	6
EXPECTED	13	13	5	10	5
χ^2 value	1.4		0.4 ^c		

^aData was derived from the typing results presented in Chapter 6.

^bAt $P < 0.05$; Calculated as $(\text{observed}-\text{expected})^2/\text{expected}$ for each entry, then the value is summed up.

^c χ^2 value with two degrees of freedom.

TABLE 5.4

HARDY-WEINBERG EQUILIBRIUM FOR D16S8 AND D16S10^aD16S8 (PvuII RFLP)

GENOTYPE	OBSERVED	EXPECTED
A1/A1	7	7
A1/A2	13	13
A2/A2	6	6
TOTAL	26	26
χ^2 value ^b	0.00 ^c	

D16S10 (RsaI RFLP)

GENOTYPE	OBSERVED	EXPECTED
B1/B1	8	7.99
B1/B2	6	5.91
B2/B2	1	1.09
TOTAL	15	15
χ^2 value ^b	0.80 ^c	

D16S10 (TaqI RFLP)

GENOTYPE	OBSERVED	EXPECTED
A1/A1	8	7.7
A1/A2	9	9.4
A2/A2	3	2.9
TOTAL	20	20
χ^2 value ^b	0.03 ^c	

^a Allele frequencies used in the calculations (Cavalli-Sforza and Bodmer, 1971) were derived from Table 5.2.

^b At $P < 0.05$; Calculated as $(\text{observed} - \text{expected})^2 / \text{expected}$ for each entry, then the value is summed up.

^c χ^2 value with two degrees of freedom.

TABLE 5.5

SOUTHERN BLOT RESULTS FOR pACHF1

<u>XbaI</u>		<u>HindIII</u> + <u>XbaI</u>		<u>HindIII</u>		<u>EcoRI</u> + <u>XbaI</u>		<u>EcoRI</u> + <u>HindIII</u> + <u>XbaI</u>		<u>EcoRI</u> + <u>HindIII</u>	
FRAG.	KB	FRAG.	KB	FRAG.	KB	FRAG.	KB	FRAG.	KB	FRAG.	KB
1	<u>4.55</u> ^a	1	<u>4.55</u>	1	<u>6.14</u>	1	<u>4.11</u>	1	2.62	1	3.91
2	<u>4.11</u>	2	<u>2.14</u>	2	<u>2.25</u>	2	2.62	2	<u>2.14</u>	2	2.62
3	2.25	3	1.94	3	1.12	3	2.37	3	1.94	3	<u>2.25</u>
		4	0.96	4	0.96	4	<u>1.67</u>	4	1.67	4	1.12
		5	0.83					5	0.96	5	0.96
								6	0.83		

^aUnderlined restriction fragments hybridized strongly with ³²P-labelled, nick-translated, total human genomic DNA.

TABLE 5.6
SOUTHERN BLOT RESULTS FOR λ 221

<u>EcoRI</u>		<u>EcoRI + XbaI</u>		<u>XbaI</u>	
FRAG.	KB	FRAG.	KB	FRAG.	KB
1	19.6	1	19.6	1	21.0
2	<u>12.5</u> ^a	2	12.0	2	15.0
3	12.0	3	<u>6.7</u>	3	<u>6.7</u>
4	3.2	4	<u>5.9</u> ^b	4	<u>5.9</u> ^b
		5	3.5	5	3.5 ^c
		6	2.5	6	3.0
		7	<u>1.3</u>	7	<u>1.3</u>
		8	1.0	8	1.0

^aUnderlined restriction fragments hybridized with ³²P-labelled total human genomic DNA.

^bPartial digest fragment, which most likely was composed of the 3.5, 1.3, and 1.0 kb XbaI fragments.

^cFragment was isolated and subcloned into dephosphorylated XbaI-cut pSP64.

The allele frequencies (5.2.2) and the PIC values for both λ 247 and λ 221 was determined (Table 5.2).

λ 221 was additionally screened for the detection of RFLPs with the following restriction endonucleases: BstXI, DraI, EcoRV, HaeIII, NsiI, SacI and XbaI. The filters containing human DNAs digested with these enzymes were kindly provided by Dr. V. Hyland. λ 221 did not detect RFLPs with these enzymes (Table 5.1).

A restriction fragment from pACHF1, a subclone from λ 247, was subcloned into pSP64 and named pACHF1.3 (Fig. 5.3). This subclone contained a unique 2.25 kb XbaI fragment but did not detect the PvuII RFLP (Fig. 5.3). The other subclone, pACHF1.1, contained a 1.67 kb EcoRI-XbaI fragment that was re-ligated into pUC18 (Fig. 5.3). This subclone detected the PvuII RFLP, however the cloned insert still required pre-reassociation (Table 5.7).

A 3.5 kb XbaI fragment was subcloned from λ 221 into pSP64 and named pACHF3.5 (Table 5.7). The insert in pACHF3.5 contained repetitive sequences that produced some lane background in the tracks with human DNA, however, pre-reassociation was not required. pACHF3.5 detected both the RsaI and TaqI RFLPs (Fig. 5.4). The RsaI and TaqI RFLPs displayed linkage disequilibrium - the A1B1 and A2B2 haplotypes were co-inherited together (Fig. 5.5) in Utah Family 985 (Appendix D). Although the other Utah families were not typed for the RsaI RFLP, all the parents from the families were typed and each had identical TaqI haplotypes (Table 6.4). In addition, the A1B1 and A2B2 haplotypes (only the double homozygotes were considered) were found in 14 unrelated human genomic DNAs.

5.4 DISCUSSION

Two of the regionally assigned chromosome 16 clones detected RFLPs.

FIGURE 5.3

RESTRICTION MAPS OF pACHF1 AND THE SUBCLONES pACHF1.1 and pACHF1.3^a

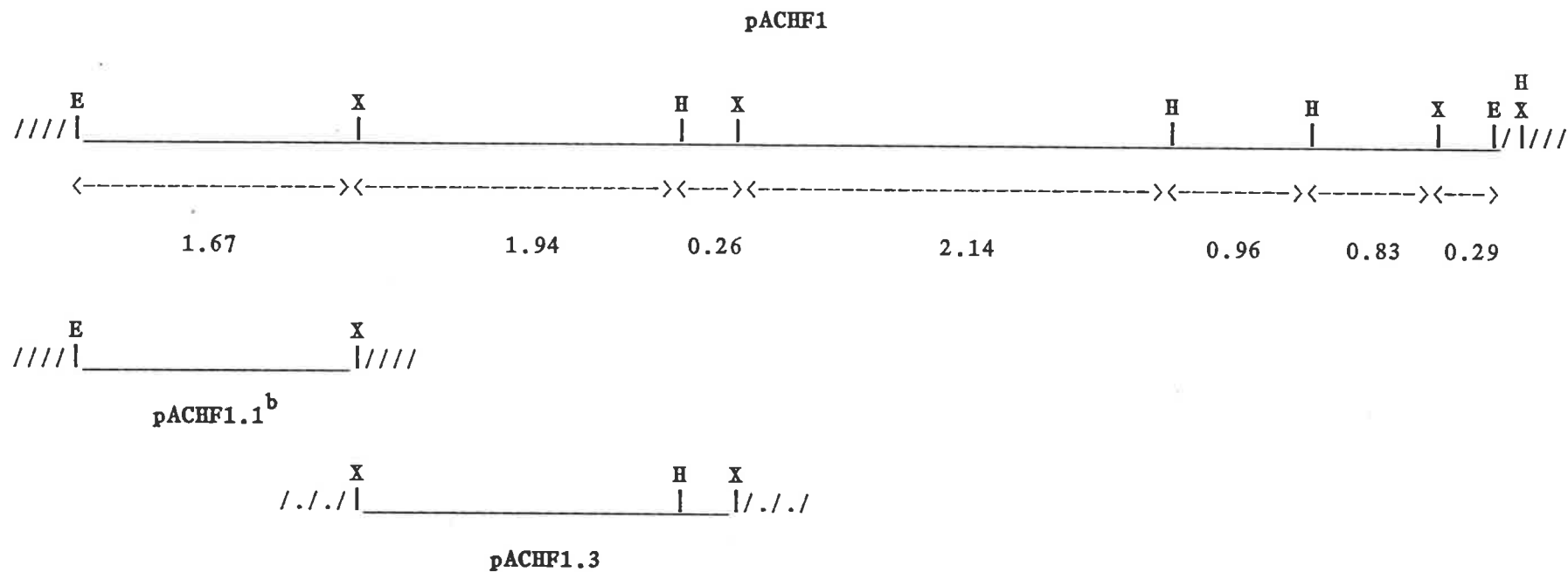

^aKey to figure: E EcoRI, H HindIII, X XbaI, /// pUC18 and ./ pSP64.
Restriction fragment sizes in kb.

^bDetects the PvuII RFLP.

FIGURE 5.4

RsaI AND TaqI RFLPS IDENTIFIED BY pACHF3.5 (D16S10)

pACHF3.5, a subclone derived from λ 221 (D16S10), was ^{32}P -labelled by nick-translation and hybridized to Southern blot filters containing six unrelated Caucasian genomic DNAs (10 μg) restricted with either RsaI or TaqI. The washed filters were exposed overnight at -70°C and then developed.

pACHF3.5 produced hybridizing fragments of 2.6 (B1 allele), 1.84 (B2 allele), 0.8 (invariant) and 0.76 kb (B2 allele) on the RsaI filter. The genotypes of the samples were as follows: 1 (B1/B1); 2 (B1/B1); 3 (B1/B2); 4 (B2/B2); 5 (B1/B1); 6 (B1/B2).

pACHF3.5 produced hybridizing fragments of 5.4 (A2 allele), 4.5 (invariant) and 1.3 kb (A1 allele) on the TaqI filter. The genotypes of the samples were as follows: 1 (A1/A1); 2 (A1/A1); 3 (A1/A2); 4 (A2/A2); 5 (A1/A1); 6 (A1/A2).

The RsaI and TaqI restriction fragments detected by pACHF3.5 are precisely as predicted from the restriction map of pACHF3.5 (Figure 5.5).

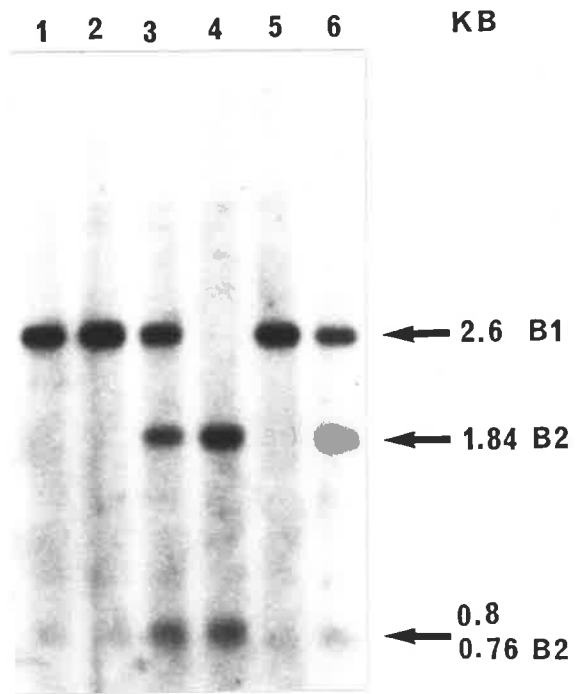

RsaI

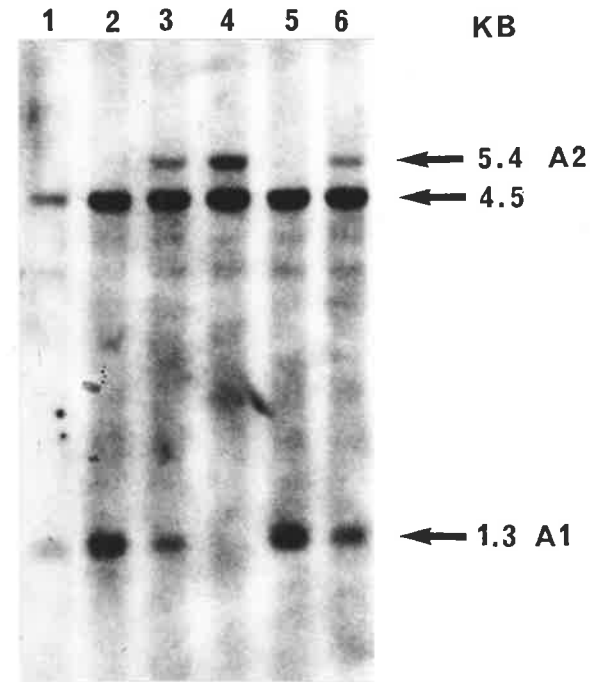

TaqI

FIGURE 5.5

RESTRICTION MAP OF pACHF3.5 AND λ 221

The restriction maps of pACHF3.5 and λ 221 were determined as described in the text (5.2.3.2). The A1/B1 haplotype occurs when the T site is present (+) and the R site is absent (-). The A2/B2 haplotype occurs when the T site is absent (-) and the R site is present (+).

Key :

R RsaI; R polymorphic RsaI site.

T TaqI; T polymorphic TaqI site.

X XbaI.

./ pSP64.

CLONE

pACHF3.5



λ221

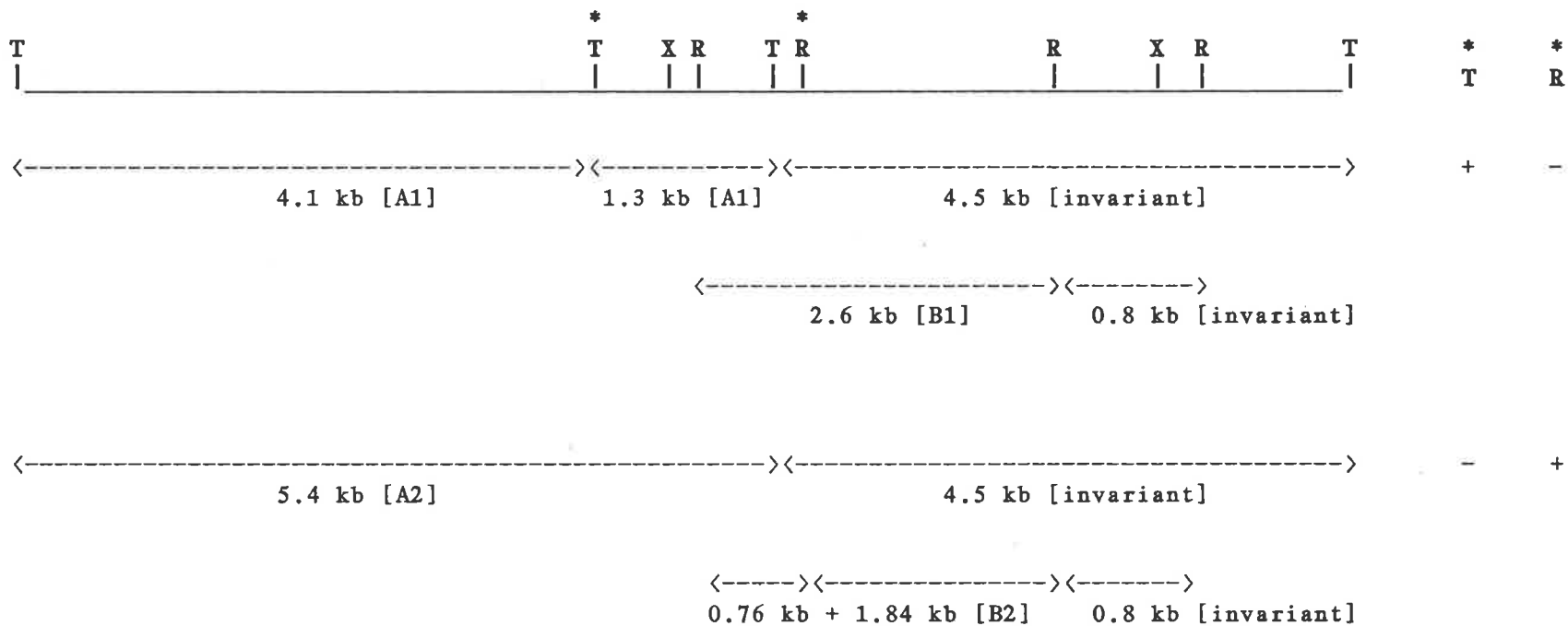

TABLE 5.7

RFLP DETAILS OF THE SUBCLONES

NAME	INSERT SIZE(KB)	VECTOR	ENZYME	CONSTANT BAND(S) SIZE(KB)	POLYMORPHIC BANDS			PIC	SAMPLE SIZE (CHROMOSOMES)
					ALLELE	SIZE(KB)	FREQUENCY		
pACHF1.1	1.7	pUC18	<u>PvuII</u>	-	A1	3.80	0.52	0.38	52
					A2	2.20	0.48		52
pACHF3.5	3.5	pSP64	<u>RsaI</u>	0.8	B1	2.60	0.73	0.32	30
					B2	1.84	0.27		30
						0.76			
			<u>TaqI</u>	4.5	A1	1.30	0.62	0.36	40
				A2	5.40	0.38		40	

All three RFLPs demonstrated Mendelian inheritance, showed Hardy-Weinberg equilibrium and detected two alleles (Table 5.2). The subclone from λ 247, pACHF1.1, detected the PvuII RFLP but still required pre-reassociation (Fratini *et al.*, 1988b). From the restriction map of pACHF1.1, the PvuII RFLP was localized to a 1.77 kb EcoRI-XbaI fragment.

The subclone from λ 221, pACHF3.5, was polymorphic for both RsaI and TaqI (Fratini *et al.*, 1988c). From the restriction map of pACHF3.5 it was determined that the putative RsaI and TaqI polymorphic sites were 1.5 kb apart (Fig. 5.5). When the polymorphic RsaI site was present (+) the polymorphic TaqI site was absent (-), and vice-versa (Fig. 5.5).

One explanation as to why no A1B2 and A2B1 haplotypes were found is that the probability of recombination between the two polymorphic sites, only 1.5 kb apart, would be quite low (Fig. 5.5). The alternative explanation was that not enough individuals had been screened to detect these haplotypes (Hill, 1974).

Both clones were relatively informative as genetic markers based on their PIC values (Table 5.6). The maximum possible PIC value for a two allele polymorphism is 0.38 (Botstein *et al.*, 1980). The clones were used to type the Utah families to determine which of these were informative so that linkage analysis could be done with other informative markers on chromosome 16 (Chapter 6). In addition, λ 247 was used to type a FRA16A family and λ 221 was used to type informative FRA16B families to determine if the clones were linked to these fragile sites (Chapter 7).

To date, 86 anonymous DNAs had been assigned to chromosome 16, of which 66 detected RFLPs (Ropers *et al.*, 1987). Of the 22 cloned genes assigned to chromosome 16, 11 detected RFLPs, taking the total of polymorphic loci on chromosome 16 to 77 (Ropers *et al.*, 1987).

5.5 SUMMARY

Two of the eight regionally assigned anonymous DNAs that mapped to chromosome 16 detected RFLPs. λ 247 (D16S8) was polymorphic for PvuII and λ 221 (D16S10) was polymorphic for RsaI and TaqI. The three RFLPs demonstrated Mendelian Inheritance and Hardy-Weinberg equilibrium. Both clones were relatively informative as genetic markers based on their PIC values.

pACHF1.1, a subclone from pACHF1 (D16S8), detected the PvuII RFLP and pACHF3.5, a subclone from λ 221, detected the RsaI and TaqI RFLPs. The RsaI and TaqI RFLPs displayed linkage disequilibrium.

CHAPTER 6

LINKAGE ANALYSIS STUDIES: THE UTAH FAMILIES

6.1 INTRODUCTION

This chapter presents the DNA typing results of the informative Utah families for the polymorphic clones $\lambda 247$ (D16S8) and $\lambda 221$ (D16S10) (Chapter 5), as well as for clones that were isolated by other investigators and were found to map in the same regions as D16S8 and D16S10. The data derived from the typing results was analyzed for any possible linkages between the clones so that linkage groups could be established.

The Utah families (Appendix A) are useful for such linkage analysis studies since they potentially provide a much higher number of informative meioses than smaller incomplete families (White *et al.*, 1985a) such as the fragile site families (Appendix B).

An overview into basic linkage analysis techniques used in this study is presented below.

6.2 LINKAGE ANALYSIS

Genetic linkage occurs when two or more loci on a single chromosome have a tendency to be inherited together, that is, they no longer independently assort at meiosis (Conneally and Rivas, 1980). Linked loci are either on the same homologous chromosome (coupling phase) or are on different homologous chromosomes (repulsion phase).

Linkage between genetically linked loci is usually not complete, since recombination at meiosis, can separate the linked loci. Offspring that have the new allelic combinations, caused by recombination, are referred to as recombinants. The proportion of recombinants out of all opportunities for recombination (recombinants and non-recombinants) is referred to as the recombination fraction (θ) (Renwick, 1971). For unlinked loci the recombination fraction is 50 percent, and for linked loci it is less than 50 percent.

Two or more generation families, such as the Utah families

(Appendix A), where at least one parent was heterozygous for both loci (informative) are required to distinguish recombinants from non-recombinants. Families in which neither parent was doubly heterozygous, or that the linkage phase of the parents was unknown, provide phase unknown information for linkage analyses.

In three generation families, such as the Utah families (Appendix A), the linkage phase of the second generation can be determined by inspection of the pedigree. Knowing the linkage phase of the parents allows the recombination fraction to be calculated by determining the number of recombinants and non-recombinants in the offspring (Emery, 1976). In two generation families the linkage phase is unknown between a pair of linked loci. In order to calculate the recombination fraction in these families the sequential method of Morton (1955) is used. Morton's method uses the maximum likelihood estimation of the recombination fraction.

The measure of support for linkage of a pair of loci, the lod score (z), is defined as the \log_{10} of the ratio of the probability that the data would have arisen if the loci were linked ($0.0 > \theta < 0.5$) to the probability that the data would have arisen if the loci were unlinked ($\theta = 0.5$) (Morton, 1955). The relative probability (P_r) of having obtained a family for a given value of θ is calculated by the formula:

$$P_r = \frac{P(\text{family, given } \theta = 0.0, 0.05, 0.1, \dots, 0.5)}{P(\text{family, given } \theta = 0.5)}$$

The lod score is calculated by the formula: $z = \log_{10}(P_r)$.

The lod score is additive over families, whether of two or more generations. The conventional threshold for declaring linkage is a lod score of + 3.0 (odds of a 1,000:1 in favour of linkage) and a lod score

of less than or equal to -2 (odds 100:1 against linkage) would exclude linkage (Morton, 1955). The maximum likelihood estimate of θ is obtained from a relative probability curve, by plotting the sum of the lod scores against values of θ (0.0- \rightarrow 0.5) and taking the θ value at the peak of the curve (Emery, 1976). This value is usually calculated by a computer program called LIPED (Ott, 1974, 1976). LIPED calculates the likelihoods and lod scores for given values of θ .

There is a relationship between the recombination fraction (θ) and genetic map distance (D): one percent recombination ($\theta = 0.01$) is equal to one map unit or 1 cM (Kosambi, 1944). This relationship holds true for values of θ up to 0.25 in males (Conneally and Rivas, 1980). The map distance, in cM, can be calculated from the formula derived by Kosambi (1944): $D = 57.57 \times \log_{10} (1 + 2\theta)/(1 - 2\theta)$.

The discovery of RFLPs, combined with the use of lod score analysis methods as outlined in this chapter, has had an enormous impact in genetic linkage studies (1.4.6). This methodology was used to construct a genetic linkage map of the human genome (Donis-Keller *et al.*, 1987).

6.3 METHODS

6.3.1 PREPARATION OF FILTERS

Genomic DNA (10 μ g) from the parents of the Utah families (Appendix A) was digested with the restriction endonucleases PvuII, RsaI and TaqI and electrophoresed in 0.8% agarose gels in 1xTBE buffer (2.1.3). The gels were Southern blotted (2.2.11) onto GeneScreen Plus nylon membranes. The filter containing the PvuII digests was prehybridized then hybridized (2.2.14) with 32 P-labelled, nick-translated (2.2.12.1), pre-reassociated (2.2.13) λ 247 (D16S8). The filters containing the RsaI and TaqI digests were prehybridized then hybridized with 32 P-labelled, nick-translated, pre-reassociated λ 221 (D16S10).

Genomic DNA from the Utah Families that were informative for D16S8 and D16S10 were digested with the appropriate enzymes, and filters were prepared and probed with the corresponding λ clone.

6.3.2 ADDITIONAL TYPING RESULTS

The Utah families were typed with several probes that were isolated by other investigators from the group as well as probes that were obtained from other research groups. The Utah families were typed with the 3'HVR probe by A. Gedeon and L. Bates. The informative Utah families were typed with D16S79 by A. Gedeon. The information regarding the RFLPs detected by D16S8, D16S79 and 3'HVR is presented in Table 6.1.

The anonymous DNA clone, ACH207 (D16S4), was isolated from a flow-purified chromosome 16 library (Hyland *et al.*, 1988a). The informative Utah families were typed with ACH207 by Dr. V. Hyland, A. Gedeon and L. Bates. The typing of the informative Utah families with HP and MT was done by Dr. V. Hyland, A. Gedeon and L. Bates. The information regarding the RFLPs detected by D16S4, D16S10, HP and MT is presented in Table 6.2.

6.4 RESULTS

6.4.1 DNA TYPING RESULTS

Only the DNA typing results that provided the most useful information are presented in the appropriate Tables, for the sake of brevity. Other information such as lod scores obtained between specific pairs of loci are summarized in the appropriate Tables as indicated in the text and found in Callen *et al.* (1988b) and Mulley *et al.* (1988).

The typing results for the Utah parents with D16S8 and D16S79 are shown in Table 6.3. The typing results for the Utah parents with D16S4 and D16S10 are shown in Table 6.4. D16S8 and D16S79 were both informative in Utah families 981, 982, 984 and 985 (Table 6.3) and the typing

TABLE 6.1

MARKERS EXAMINED FOR LINKAGE STUDIES: 16p PROBES

MARKER	RFLP	LOCALIZATION	REFERENCE
<u>D16S8</u>	<u>PvuII</u>	16p13.3-→p13.11	Fratini <u>et al.</u> (1988b).
<u>D16S79</u> ^a	<u>TaqI</u>	16p13.3-→p13.11	Breuning <u>et al.</u> (1988).
3'HVR	<u>PvuII</u> , <u>RsaI</u>	16pter-→p13.2	Simmers <u>et al.</u> (1987b).

^aRecognizes two independent TaqI RFLPs, one with two alleles (A1, A2), and the other with three alleles (B1, B2, B3). For convenience, the following codes were used for the six possible haplotypes: A - A1B1; B - A1B2; C - A1B3; D - A2B1; E - A2B2; F - A2B3 (Table 6.3; Appendix C).

TABLE 6.2

MARKERS EXAMINED FOR LINKAGE STUDIES: 16q PROBES

MARKER	RFLP	LOCALIZATION	REFERENCE
<u>D16S4</u>	<u>MspI</u> , <u>TaqI</u>	16q22.100-→q22.102	Callen <u>et al.</u> (1988a).
<u>D16S10</u>	<u>RsaI</u> , <u>TaqI</u>	16q21-→q22.100	Fratini <u>et al.</u> (1988c).
<u>HP</u>	<u>EcoRI</u> , <u>HindIII</u>	16q22.105-→q22.108	Simmers <u>et al.</u> (1986).
<u>MT</u>	<u>TaqI</u>	16q21-→q22.100	Callen <u>et al.</u> (1988a).

TABLE 6.3

TYPING RESULTS OF THE UTAH FAMILY PARENTS WITH
D16S8 AND D16S79

UTAH FAMILY ^a	PARENTS GM. No	MARKERS	
		<u>D16S8</u>	<u>D16S79</u>
		<u>PvuII</u>	<u>TaqI</u>
981	6995	<u>A1/A2</u> ^b	<u>B/E</u>
	6997	<u>A1/A2</u>	<u>B/E</u>
	7042	A1/A1	<u>D/E</u>
	7014	<u>A1/A2</u>	<u>B/D</u>
	7046	<u>A1/A2</u>	<u>B/E</u>
	7041	A2/A2	B/B
	7434	<u>A1/A2</u>	<u>D/E</u>
	7013	<u>A1/A2</u>	<u>B/B</u>
982	6990	<u>A1/A2</u>	<u>B/E</u>
	7057	A2/A2	<u>B/E</u>
983	6987	A1/A1	<u>B/E</u>
	7038	<u>A1/A2</u>	E/E
984	7019	<u>A1/A2</u>	<u>B/E</u>
	7029	<u>A1/A2</u>	<u>D/E</u>
985	6991	A2/A2	<u>D/E</u>
	7048	<u>A1/A2</u>	<u>E/F</u>
1029	7348	A1/A1	-
	7349	A2/A2	-

^aSee Appendix A for pedigree details.

^bInformative parent(s) are underlined.

results of these families are presented in Appendix C. D16S4 and D16S10 were both informative in Utah families 981, 984, 985 and 1029 (Table 6.4) and the typing results are presented in Appendix D.

The RsaI and TaqI haplotypes for D16S10 were identical in all the Utah parents (Table 6.4) as well as for Utah family 985, which was fully typed for the RsaI RFLP (Appendix D).

6.4.2 LINKAGE STUDIES WITH D16S8 AND D16S79

The number of recombinants and non-recombinants between D16S8 and D16S79, obtained by inspection of the informative Utah families (Appendix C), are summarized in Table 6.5. The lod scores were calculated using standard lod tables and are shown in Table 6.6. There were at least three recombinants out of 39 informative meioses between D16S8 and D16S79 (Appendix C; Table 6.5). Taking into account the four phase unknown meioses in Utah family 981 (Appendix C, generation II: GM6995, 7042, 7046 and GM7434), the maximum lod score between D16S8 and D16S79 was $\hat{z} = 6.90$ at $\hat{\theta} = 0.08$ (odds of $7.9 \times 10^6:1$ in favour of linkage). A map distance of between 2-20 cM (90% confidence level) between D16S8 and D16S79 was calculated using the method outlined in Conneally *et al.* (1985).

6.4.3 LINKAGE STUDIES WITH D16S10, MT, D16S4 AND HP

The number of recombinants and non-recombinants between D16S10 and MT, D16S4 and HP were obtained by inspection of the informative Utah families (Appendix D). The lod scores were calculated using standard lod tables and are shown in Table 6.8. No recombinants were found in the MT, D16S10-D16S4-HP cluster from the informative Utah sibships (Table 6.8), hence the loci could not be ordered.

There were no recombinants out of 29 informative meioses between

TABLE 6.4

TYPING RESULTS OF THE UTAH FAMILY PARENTS WITH
D16S4 AND D16S10

UTAH FAMILY ^a	PARENTS GM. No	MARKERS			
		<u>D16S4</u>	<u>D16S4</u>	<u>D16S10</u>	<u>D16S10</u>
		<u>TaqI</u>	<u>MspI</u>	<u>TaqI</u>	<u>RsaI</u>
981	6995	<u>A2/A2</u>	B1/B1	<u>A1/A2</u> ^b	<u>B1/B2</u>
	6997	<u>A2/A2</u>	<u>B1/B2</u>	A1/A1	B1/B1
	7042	<u>A1/A2</u>	B1/B1	<u>A1/A2</u>	<u>B1/B2</u>
	7014	<u>A2/A2</u>	B1/B1	<u>A1/A2</u>	<u>B1/B2</u>
	7046	<u>A1/A2</u>	B1/B1	<u>A1/A2</u>	<u>B1/B2</u>
	7041	<u>A2/A2</u>	B1/B1	A1/A1	B1/B1
	7434	<u>A1/A2</u>	B1/B1	<u>A1/A2</u>	<u>B1/B2</u>
	7013	A1/A1	B1/B1	A1/A1	B1/B1
982	6990	<u>A2/A2</u>	B2/B2	A1/A1	B1/B1
	7057	<u>A1/A2</u>	B1/B1	A1/A1	B1/B1
983	6987	<u>A2/A2</u>	B1/B1	A1/A1	B1/B1
	7038	<u>A1/A2</u>	<u>B1/B2</u>	A2/A2	B2/B2
984	7019	-	B1/B1	<u>A1/A2</u>	<u>B1/B2</u>
	7029	-	<u>B1/B2</u>	<u>A1/A2</u>	<u>B1/B2</u>
985	6991	-	B1/B1	<u>A1/A2</u>	<u>B1/B2</u>
	7048	-	<u>B1/B2</u>	<u>A1/A2</u>	<u>B1/B2</u>
1029	7348	<u>A1/A2</u>	-	<u>A1/A2</u>	<u>B1/B2</u>
	7349	<u>A2/A2</u>	-	A1/A1	B1/B1

^a See Appendix A for pedigree details.

^b Informative parent(s) are underlined.

TABLE 6.5

SUMMARY OF RECOMBINANTS (R) AND NON-RECOMBINANTS (NR) IN
 THE UTAH FAMILIES FOR D16S8 AND D16S79^a

UTAH FAMILY	R	NR
981 ^b	2	14
982	—	9
984	—	6
985	1	7
TOTAL	3	36

^aSee Appendix C for complete typing results and identification of R and NR individuals.

^bIncludes one phase unknown R and three phase unknown NR.

TABLE 6.6

LOD SCORES AND RECOMBINATION FRACTIONS FOR D16S8 AND D16S79

LINKAGE COMPARISON	θ						$\hat{\theta}$	\hat{z}
	0.01	0.05	0.10	0.20	0.30	0.40		
<u>D16S8</u>								
: <u>D16S79</u>	5.28	6.74	6.80	5.88	4.37	2.42	0.08	6.90

D16S4 and D16S10 (Table 6.7). Taking into account the seven phase unknown meioses in Utah family 1029 (Appendix D, generation III) the maximum lod score between D16S4 and D16S10 was $\hat{z} = 8.30$ at $\hat{\theta} = 0.00$ (odds of $203 \times 10^6:1$ in favour of linkage). A map distance of between 0-7 cM (90% confidence level) between D16S4 and D16S10 was calculated using the method outlined in Conneally *et al.* (1985). D16S10 demonstrated linkage to the HP locus with a lod score $\hat{z} = 2.96$ at $\hat{\theta} = 0.00$ (odds of a 912:1 in favour of linkage) (Table 6.8). Additional data would be required to determine the recombination fraction between D16S10 and MT (Table 6.8).

6.5 DISCUSSION

6.5.1 16p LINKAGE GROUP

D16S8 was mapped to 16p13.3- \rightarrow p13.11 (Table 4.3) and was further localized by *in situ* hybridization as distal to FRA16A (Callen *et al.*, 1988b). D16S79 mapped to the same region as D16S8 (Table 6.1). Both probes were further localized by Dr. V. Hyland to 16p13.12- \rightarrow p13.11 using a new hybrid cell line (CY19) (Callen *et al.*, 1988b). Linkage analysis between D16S8 and D16S79 indicated that both loci were linked with a recombination fraction of eight percent. The order of the loci could be given a probable orientation with respect to FRA16A by observing recombination between one of the loci and not the other with FRA16A (Chapter 7).

6.5.2 16q LINKAGE GROUP

D16S10 was mapped to 16q13- \rightarrow q22.1 (Table 4.3) and further localized by *in situ* hybridization to 16q21- \rightarrow q22.100, proximal to FRA16B (Callen *et al.*, 1988a). D16S4 was mapped to 16q22.100- \rightarrow q22.102 (Callen *et al.*, 1988a) which was distal to FRA16B. Hence both probes flanked FRA16B and

TABLE 6.7

SUMMARY OF RECOMBINANTS (R) AND NON-RECOMBINANTS (NR) IN
THE UTAH FAMILIES FOR D16S4 AND D16S10^a

UTAH FAMILY	R	NR
981	-	15
984	-	1
985	-	6
1029 ^b	-	7
TOTAL	0	29

^aSee Appendix D for complete typing results and identification of R and NR individuals.

^bIncludes seven phase unknown NR.

TABLE 6.8

LOD SCORES AND RECOMBINATION FRACTIONS FOR D16S10, MT,
D16S4 AND HP^a

LINKAGE COMPARISON	θ						Recombination
	0.01	0.05	0.10	0.20	0.30	0.40	Fraction
<u>D16S10</u>							
: <u>MT</u>	<u>0.30</u>	0.28	0.26	0.20	0.15	0.08	0/1
: <u>D16S4</u>	<u>8.30</u>	7.78	7.10	5.62	3.94	2.02	0/29 ^b
: <u>HP</u>	<u>2.96</u>	2.74	2.46	1.86	1.22	0.57	0/12

^aLod score values for MT and HP were derived from Mulley *et al.* (1988).

^bNumber of recombinants (R) and non-recombinants (NR) from the Utah families are summarized in Table 6.7 and presented in Appendix D.

quite possibly FRA16C which maps to the same location (1.5.7). D16S10 was not linked closely to either D16S5 (mapped to 16q23.1->q24) and APRT (mapped to 16q24->qter), a finding consistent with the chromosomal localizations of the probes (Mulley *et al.*, 1988).

6.5.3 GENERAL DISCUSSION

The two polymorphic markers, D16S8 and D16S10, proved to be useful in linkage studies with other markers that were mapped to identical intervals as D16S8 and D16S10. The use of Southern blot analysis with the chromosome 16 somatic cell hybrids (Callen, 1986; Callen *et al.*, 1988b) combined with *in situ* hybridization (Callen *et al.*, 1988a, 1988b) has allowed both D16S8 and D16S10, as well as other markers, to be mapped to fairly precise chromosomal regions. Such precise localizations are essential as reference points for the construction of chromosome linkage maps (Donis-Keller *et al.*, 1987).

D16S8 formed a tight linkage group with D16S79, both of which mapped distal to FRA16A (Callen *et al.*, 1988b). D16S79 had a 32 percent recombination fraction with the 3'HVR (Breuning *et al.*, 1988). D16S8 had a 36 percent recombination fraction with the 3'HVR. This value was derived from segregation data in Utah families 982, 983, 984 and 985. This gave the loci order: 16pter, 3'HVR-D16S79, D16S8-FRA16A-cen (Callen *et al.*, 1988b). The linkage analysis of D16S8 and D16S79 to FRA16A is presented in Chapter 7.

D16S10 formed a tight linkage group with D16S4 and HP. Since all three loci had been mapped to precise locations on the long arm of chromosome 16 the order was determined as: cen-MT, D16S10-FRA16B-D16S4-HP-FRA16D-D16S5-APRT-qter (Mulley *et al.*, 1988). In addition to these loci, the genes for chymotrypsinogen B (CTRB), lecithin:cholesterol acyltransferase (LCAT) and tyrosine aminotransferase (TAT) were local-

ized with respect to FRA16B and four translocations with breakpoints in 16q22 by Southern blot analysis and in situ hybridization (Callen et al., 1988a). The order of these loci was: cen-FRA16B-LCAT-HP-TAT, CTRB-FRA16D-qter. Together, with the previous localizations of MT, D16S10, D16S4, D16S5 and APRT, this gave the following loci order of: cen-MT, D16S10-FRA16B-D16S4, LCAT-HP, TAT, CTRB-FRA16D-D16S5-APRT-qter.

The linkage analysis of D16S10 and D16S4 with respect to FRA16B is presented in Chapter 7. The localizations of both D16S8 and D16S10 will now allow other polymorphic markers to be ordered with respect to these loci and the corresponding fragile sites, FRA16A and FRA16B.

6.6 SUMMARY

D16S8 and D16S79, both of which mapped distal to FRA16A, were linked with a maximum lod score $\hat{z} = 6.90$ at $\hat{\theta} = 0.08$ which corresponded to a map distance of between 2-20 cM. D16S79 had a 32 percent recombination fraction with the 3'HVR. D16S8 had a 36 percent recombination fraction with the 3'HVR. This gave the loci order: 16pter, 3'HVR-D16S79, D16S8-FRA16A-cen.

No recombinants were found in the MT, D16S10-D16S4-HP cluster. The maximum lod score between D16S4 and D16S10 was $\hat{z} = 8.30$ at $\hat{\theta} = 0.00$ which corresponded to a map distance of between 0-7 cM (90% confidence level). D16S10 demonstrated linkage to the HP locus with a maximum lod score $\hat{z} = 2.96$ at $\hat{\theta} = 0.00$. D16S10 was not linked closely to either D16S5 and APRT. The loci order was determined as: cen-MT, D16S10-FRA16B-D16S4-HP-FRA16D-D16S5-APRT-qter.

CHAPTER 7

LINKAGE ANALYSIS STUDIES: THE FRAGILE SITE FAMILIES

7.1 INTRODUCTION

This chapter presents the DNA typing results of the informative fragile site families for D16S8 and D16S10. The data was analyzed using the method of maximum likelihood (6.2) to investigate any possible linkage with the loci and FRA16A and FRA16B.

7.2 METHODS

Genomic DNA (10 µg) from the key individuals of the FRA16A and FRA16B families (Appendix B) were digested with the appropriate restriction endonucleases (PvuII or TaqI) and electrophoresed in 0.8% agarose gels in 1xTBE buffer (2.1.3). The gels were Southern blotted (2.2.11) onto GeneScreen Plus nylon membranes. The filter containing the PvuII digests was prehybridized then hybridized (2.2.14) with ³²P-labelled, nick-translated (2.2.12.1), pre-reassociated (2.2.13) λ247 (D16S8). The filters containing the TaqI digests were prehybridized then hybridized with ³²P-labelled, nick-translated, pre-reassociated λ221 (D16S10). Genomic DNA from the FRA16A family was digested with PvuII and the prepared filters were probed with λ247 (D16S8). Genomic DNA from the informative FRA16B families were digested with TaqI and the prepared filters were probed with λ221 (D16S10). The FRA16A family was typed with D16S79 by A. Gedeon. The lod scores were calculated by the computer program LIPED (2.2.16).

7.3 RESULTS

The key individuals in the FRA16A family (10556) were informative for D16S8, hence the entire family was typed with D16S8 (Appendix E). The informative key individuals for D16S10 in the FRA16B families are shown in Table 7.1 and the typing results of the informative families are presented in Appendix F.

The lod scores between FRA16A and D16S8 are presented in Table 7.2. No recombinants were observed between FRA16A and D16S8 ($\hat{z} = 2.84$, $\hat{\theta} = 0.00$) (Table 7.2). There were insufficient informative meioses to establish the map distance between FRA16B and D16S10. However, from the available data, no recombinants were observed between FRA16B and D16S10 ($\hat{z} = 1.06$, $\hat{\theta} = 0.13$) (Table 7.3). The recombination fraction of 13 percent between FRA16B and D16S10 was most likely due to an artifact of linkage analysis using phase unknown meioses and missing individuals (Appendix F).

7.4 DISCUSSION

Both D16S8 and D16S10 showed evidence of linkage to FRA16A and FRA16B respectively. D16S8 was linked to FRA16A with a maximum lod score $\hat{z} = 2.84$ at $\hat{\theta} = 0.00$. D16S10 demonstrated linkage with FRA16B with a maximum lod score $\hat{z} = 1.06$ at $\hat{\theta} = 0.13$, although additional FRA16B families would need to be typed for D16S10 to obtain an accurate estimate of the recombination fraction.

D16S79 (Breuning *et al.*, 1988), which was linked to D16S8 ($\hat{z} = 6.90$, $\hat{\theta} = 0.08$) (Table 6.6), also demonstrated linkage to FRA16A ($\hat{z} = 4.53$, $\hat{\theta} = 0.11$) (Callen *et al.*, 1988b). One individual in the FRA16A family (Generation IV, 3; see Appendix E) was a recombinant between D16S79 and FRA16A and a recombinant between D16S8 and D16S79, but was not a recombinant between D16S8 and FRA16A. The most likely order of the loci with respect to FRA16A was: 16pter-D16S79-D16S8-FRA16A-cen (Callen *et al.*, 1988b). D16S8 was, at the time of writing, the closest polymorphic DNA marker distal to FRA16A. The order of loci that was established provided a linkage group in which additional RFLPs could be ordered.

D16S4 (Hyland *et al.*, 1988b), which was linked to D16S10 ($\hat{z} = 8.40$,

TABLE 7.1
 TYPING RESULTS FOR KEY INDIVIDUALS IN THE FRA16B
 FAMILIES WITH D16S10

PEDIGREE NO.	KEY INDIVIDUAL(S)	<u>D16S10</u>
12058	28	A1/A1
	31	A1/A1
16786	470	A1/A1
12273	93 (I, 2) ^a	<u>A1/A2</u> ^b
	134 (II, 1)	<u>A1/A2</u>
	91 (II, 3)	<u>A1/A2</u>
401	493	A1/A1
	333	A1/A1
16449	-	-
17043	562	A1/A1 ^c
16967	640 (II, 3)	<u>A1/A2</u>
16498	572 (II, 2)	<u>A1/A2</u>
	522 (III, 2)	<u>A1/A2</u>
	573 (III, 3)	<u>A1/A2</u>
16367	607	A2/A2
	546	A2/A2
	547	A1/A1
4139	787 (II, 6)	<u>A1/A2</u>

^aNumbers in the brackets refer to the generation and position in the pedigrees of the informative FRA16B families (Appendix B). The other number refers to the DNA sample number.

^bInformative for D16S10.

^cNon-informative for D16S10, however parts of the pedigree were typed since it provided some additional linkage information.

TABLE 7.2

LOD SCORE AND RECOMBINATION FRACTION FOR D16S8 AND FRA16A

LINKAGE	θ						$\hat{\theta}$	\hat{z}
	0.01	0.05	0.10	0.20	0.30	0.40		
<u>FRA16A</u>								
: <u>D16S8</u>	2.79	2.57	2.29	1.71	1.11	0.50	0.00	2.84

TABLE 7.3

LOD SCORE AND RECOMBINATION FRACTION FOR D16S10 AND FRA16B

LINKAGE COMPARISON	θ						$\hat{\theta}$	\hat{z}
	0.01	0.05	0.10	0.20	0.30	0.40		
<u>FRA16B</u>								
: <u>D16S10</u>	0.67	0.92	1.04	1.00	0.74	0.38	0.00	1.06

$\hat{\theta} = 0.00$) (Table 6.8), also demonstrated linkage to FRA16B ($\hat{z} = 1.95$, $\hat{\theta} = 0.05$) (Mulley *et al.*, 1988). Since the amount of linkage data from the informative FRA16B families was minimal the order of MT, D16S10, FRA16B, D16S4 and HP could not be established (Mulley *et al.*, 1988). From the *in situ* localizations of these loci with respect to FRA16B (Callen *et al.*, 1988b) the order of loci was established to be: cen-MT, D16S10-FRA16B-D16S4-HP-FRA16D-D16S5-APRT-qter. The order of MT and D16S10 could not be established by linkage analysis. Both these markers were the closest RFLPs proximal to FRA16B.

The MT, D16S10-FRA16B-D16S4-HP linkage group was the first tight linkage group around an autosomal fragile site. As soon as closely linked RFLPs proximal to FRA16A are detected, then this fragile site would also be flanked with tightly linked markers. The only other linkage group, that included a fragile site, was around the intensively studied FRAXA (Davies *et al.*, 1987).

The lod score value between D16S10 and D16S4 was derived from seven Utah kindreds. In order to obtain accurate estimates on the genetic distances between the loci in the FRA16B linkage group, it would be necessary to type the 40 CEPH families with the markers. The CEPH families are of the same structure as the Utah families which are a subset of the CEPH families.

As soon as proximal RFLPs are found that are linked to FRA16A, then these additional markers as well as the closely linked distal markers D16S8 and D16S79, can be used to type the CEPH families.

It was estimated that the region spanned from 16q22.100-→q22.102, a region where D16S4 was mapped, was in the order of 1,000-2,000 kb (1-2 cM) (Callen *et al.*, 1988a). This distance was in the order of magnitude to which the new cloning and pulsed-field gel electrophoretic technologies could conceivably be used to attempt to clone FRA16B.

The anonymous DNA clone $\lambda 64$ (D16S113), which was isolated from the CY17 library (Chapter 4), was mapped by in situ hybridization to 16q22.100- \rightarrow q22.102. This was the same region as where D16S4 was mapped (Callen et al., 1988a). D16S113 was non-polymorphic with 13 different restriction endonucleases (Table 5.1). Since D16S113 mapped to such a close region to FRA16B, any RFLP that is detected by D16S113 would be linked to FRA16B and hence should be useful as a potential marker for FRA16B. Many flanking and tightly linked RFLPs to FRA16A and FRA16B would be essential as defined starting points which could be used to clone and sequence these fragile sites by the use of the new cloning and gel electrophoretic technologies (1.4.8). The cloning of FRA16A may detect homologous sequences at FRAXA and possibly all the other folate sensitive fragile sites in the genome (Table 1.2). The cloning of FRA16B may detect other fragile sites of similar types in the genome.

The work presented in the study has made a significant contribution in the task of beginning to realize this goal by the isolation of two useful anonymous DNA clones, $\lambda 247$ (D16S8) and $\lambda 221$ (D16S10), of which D16S8 was the closest distal marker to FRA16A and D16S10 was one of the closest proximal markers to FRA16B. In addition, D16S10 was tightly linked to the closest distal marker to FRA16B, D16S4. This provided further evidence on the physical closeness of D16S10 to FRA16B.

7.5 SUMMARY

No recombinants were observed between FRA16A and D16S8 ($\hat{z} = 2.84$, $\hat{\theta} = 0.00$) and between FRA16B and D16S10 ($\hat{z} = 1.06$, $\hat{\theta} = 0.13$). D16S79, which was linked to D16S8 ($\hat{z} = 6.90$, $\hat{\theta} = 0.08$), was also linked to FRA16A ($\hat{z} = 4.53$, $\hat{\theta} = 0.11$). The most likely order of the loci with respect to FRA16A was: 16pter-D16S79-D16S8-FRA16A-cen.

D16S4, which was linked to D16S10 ($\hat{z} = 8.40$, $\hat{\theta} = 0.00$), was also

linked to FRA16B ($\hat{z} = 1.95$, $\hat{\theta} = 0.05$). From the in situ localizations of MT, D16S10, D16S4 and HP with respect to FRA16B, the order of loci was established to be: cen-MT, D16S10-FRA16B-D16S4-HP-qter.

CHAPTER 8

CONCLUDING DISCUSSION

8.1 CONCLUSIONS AND DISCUSSION

A total of 35 plaque purified human λ clones were obtained from a genomic λ Charon 4A EcoRI library, constructed from the hybrid cell line CY17. DNA pre-reassociation was used to mask out repetitive sequences in the λ clones for the purpose of mapping and searching for RFLPs without the initial need for subcloning.

Of the 13 clones that mapped to chromosome 16, eight were further localized to various regions on chromosome 16, using a chromosome 16 hybrid cell panel. Two of the regionally assigned chromosome 16 clones, λ 247 (D16S8) and λ 221 (D16S10), detected RFLPs and were further subcloned.

D16S8 and D16S79 (Breuning *et al.*, 1988), demonstrated linkage ($\hat{z} = 6.90$, $\hat{\theta} = 0.08$). There were no recombinants between D16S8 and FRA16A ($\hat{z} = 2.84$, $\hat{\theta} = 0.00$). The order of loci was determined as:
16pter-D16S79-D16S8-FRA16A-cen.

No recombinants were found in the MT, D16S10-D16S4-HP cluster from the informative Utah sibships. The polymorphic DNA marker, D16S4 (Hyland *et al.*, 1988b), was mapped distal to FRA16B (Callen *et al.*, 1988a). D16S4 and D16S10 were linked ($\hat{z} = 8.30$, $\hat{\theta} = 0.0$). D16S10 was also linked to HP ($\hat{z} = 2.96$, $\hat{\theta} = 0.0$).

No recombinants were observed between FRA16B and D16S10 ($\hat{z} = 1.06$, $\hat{\theta} = 0.13$) although the amount of linkage data derived from the FRA16B families was minimal. This gave the order of loci around FRA16B as:
cen-MT, D16S10-FRA16B-D16S4-HP-qter.

The established linkage groups around FRA16A and FRA16B can be used for the mapping and ordering of additional RFLPs with respect to these fragile sites.

To obtain accurate estimates on the genetic distances between the loci in the FRA16A and FRA16B linkage groups, it would be necessary to

type the 40 CEPH families (and possibly even more) with the markers. This project has now been commenced by others in Dr. G.R. Sutherland's group, with the RFLP markers around FRA16B, since the fragile site is flanked with tightly linked markers.

The availability of many flanking and tightly linked RFLPs to FRA16A and FRA16B would be essential as defined starting points which could be used to eventually clone and sequence these fragile sites. Some markers are now available for FRA16B.

It was estimated that the region spanned from 16q22.100→q22.102, a region where D16S4 was mapped (Callen *et al.*, 1988a), was in the order of 1,000-2,000 kb (1-2 cM) (Callen *et al.*, 1988a). This distance was in the order of magnitude to which the new cloning and pulsed-field gel electrophoretic technologies could conceivably be used to attempt to clone FRA16B.

The anonymous DNA clone λ 64 (D16S113), which was isolated from the CY17 library, was mapped by *in situ* hybridization to 16q22.100→q22.102. Despite D16S113 being non-polymorphic, a unique fragment from the clone could be utilized as a marker for the construction of long range restriction maps (Nguyen *et al.*, 1987) around the FRA16B locus by pulsed-field gel electrophoresis. Such a map is at present being constructed by Dr. R. MacKinnon. The ultimate use of the map would be to identify common restriction fragments that hybridized to clones which map to either side of FRA16B.

Carle *et al.* (1987) have developed a new cloning system, utilizing yeast artificial chromosomes (YAC), which allows for the cloning of large size (200-700 kb) DNA fragments. Such a system would be ideal for the cloning of restriction fragments that contained FRA16B. Since the cloned DNA is packaged as a chromosome, it may be possible to induce the fragile site and hence demonstrate that the cloned segment of human

DNA contained the fragile site. Suitable jumping and linking YAC-libraries could then be constructed. From such libraries, closer flanking RFLPs can be isolated by the use of chromosome jumping techniques (1.4.8). The probes can then be mapped by in situ hybridization to determine the extent and direction of the jump.

Distal and proximal DNA probes that have 'jumped' to the other side of the fragile site can be used to isolate overlapping restriction fragments from the YAC-library. These fragments would be the smallest possible DNA fragments that contained the fragile site DNA intact. Even if such fragments could be isolated from a YAC-library, it could still mean the sequencing of hundreds of kb of DNA. Since the DNA sequence at any fragile site is unknown it may not be possible to 'recognize' the fragile site DNA. Definitive proof would require sequencing DNA that was known to contain FRA16B and comparing the DNA sequence, from the same region of a non-FRA16B individual. The sequences could then be examined for any obvious differences, such as the amplification of a sequence(s).

Probes containing FRA16B DNA may detect other fragile sites of similar types in the genome. In addition, the eventual cloning of FRA16A may detect homologous sequences at the fragile X and possibly all the other folate sensitive fragile sites in the genome.

The alternative approach at attempting to clone a fragile site, apart from using closely linked and flanking RFLPs, would be to use 'direct' probes. Based on the model for a folate sensitive fragile site (Sutherland et al., 1985a), it was envisioned that an oligo-nucleotide probe such as poly(BrdU) should detect sequences similar to those postulated at the fragile site. If the fragile site arose by an amplification event then it would be expected that the genomic DNA of the fragile site individual, when digested with the appropriate enzyme,

would show up as a higher molecular weight restriction fragment than that found in a non-fragile site individual.

Initial experiments have indicated that poly(BrdU) does bind to human genomic DNA as a general smear, however discrete hybridization bands were observed against the background smear (Puspurs, unpublished observations). The model postulated for a folate sensitive fragile site also suggests other candidate oligonucleotide sequences which could be used to detect any differences in the DNA hybridization pattern between fragile site and non-fragile site individuals.

There is also a possible direct approach at attempting to clone FRA16B. Since FRA16B is induced by distamycin A, experiments could be devised in which genomic DNA from a FRA16B (homozygote), FRA16B (carrier) and a non-FRA16B individual was digested with various restriction endonucleases (with preference to those recognizing AT-rich sequences, such as DraI) and electrophoresed in agarose gels containing various concentrations of distamycin A. Distamycin A is known to retard the mobility of specific DNA restriction fragments and 'protect' specific DNA fragments from cleavage from various restriction endonucleases when the DNA is first incubated in the presence of distamycin A (reviewed in Zimmer and Wahnert, 1986). If FRA16B is caused by the amplification of a specific DNA sequence, as hypothesized for a folate sensitive fragile site, then the ethidium bromide stained distamycin A-agarose gels may reveal 'satellite-like' restriction fragments that are altered in mobility and are specific to the FRA16B individuals. Such fragments may then be cloned into suitable vectors and used as in situ hybridization probes to metaphase chromosomes expressing FRA16B to determine if they map to the fragile site.

The eventual cloning of FRA16A and FRA16B, either by direct or indirect methods, should provide some answers as to why specific

regions in the human genome manifest themselves as fragile sites when induced by highly specific conditions.

At the commencement of the thesis there were only three anonymous DNAs that detected RFLPs on chromosome 16 (HGM7, 1984). The strategy that most investigators adopted at that time, to isolate RFLPs from specific chromosomes, was similar to that employed in this thesis. Since then an additional 74, chromosome 16 derived, RFLPs have been reported (Ropers et al., 1987) as well as the development of totally new and more efficient strategies for the isolation of RFLPs. For example, FACS-sorted human chromosome specific libraries are now being constructed at the Lawrence Livermore and the Los Alamos National Laboratories that contain inserts of 15-20 kb in size (Sutherland, personal communication). These libraries would be ideal for isolating a large number of RFLPs to specific chromosomes. The libraries could be screened with the synthetic oligomeric sequences derived from the tandem repeats of the myoglobin gene, zeta-globin pseudo gene, insulin gene and the X-gene region of hepatitis B virus (Nakamura et al., 1987b). Such a screening strategy would identify highly polymorphic VNTRs, which are highly suited for linkage analyses (Nakamura et al., 1987b; White et al., 1985a). Chromosome 16 contains, at present, only a few of such highly informative markers (Ropers et al., 1987).

Several groups have now constructed preliminary linkage maps of chromosome 16 (Donis-Keller et al., 1987; Keith et al., 1987; Lathrop et al., 1987) and others are isolating RFLPs from chromosome 16 (Breuning et al., 1988; Bufton et al., 1986; Harris et al., 1987; Liu et al., 1987).

Keith et al. (1987) typed 21 of the 40 CEPH families with 41 RFLPs derived from chromosome 16. Based on the segregation data derived from the RFLPs, a linkage map of chromosome 16 was constructed (Keith et al.,

1987). Lathrop et al. (1987) typed 38 of the 40 CEPH families with nine RFLPs and constructed a primary linkage map of chromosome 16. A similar map was also constructed by Donis-Keller et al. (1987). Donis-Keller et al. (1987) have isolated several DNA markers that may be of potential interest for linkage analysis with MT, D16S10, D16S4 and FRA16B.

The DNA typing results of the informative CEPH families with D16S8 and D16S10 will be submitted to the CEPH data bank so that additional linkage relationships can be established with these probes and others that have now been isolated by Hyland et al. (1989). Markers which are tightly linked to D16S8 and D16S10 can be utilized in the construction of long range restriction maps around FRA16A and FRA16B.

BIBLIOGRAPHY

- Abruzzo, M.A., Mayer, M. and Jacobs, P.A. 1985. The effects of methionine and 5-azacytidine on fragile X expression. *Am. J. Hum. Genet.* 37: 193-198.
- Abruzzo, M.A., Pettay, D., Mayer, M. and Jacobs, P.A. 1986. The effect of caffeine on fragile X expression. *Hum. Genet.* 73: 20-22.
- Ali, S., Muller, C.R. and Epplen, J.T. 1986. DNA fingerprinting by oligonucleotide probes specific for simple repeats. *Hum. Genet.* 74: 239-243.
- Antonarakis, S.E., Kazazian, H.H. and Orkin, S.H. 1985. DNA polymorphism and molecular pathology of the human globin gene clusters. *Hum. Genet.* 69: 1-14.
- Ayme, S., Mattei, J.F., Mattei, M.G., Aurran, Y. and Giraud, F. 1976. Non-random distribution of chromosome breaks in cultured lymphocytes of normal subjects. *Hum. Genet.* 31: 143-148.
- Balazs, I., Baird, M.L., Wexler, K. and Wyman, A.R. 1986. Characterization of the polymorphic DNA fragments detected with a new probe derived from the D14S1 locus. *Am. J. Hum. Genet.* 39: 229A.
- Balazs, I., Purrello, M., Alhadeff, B., Grzeschik, K.-H. and Szabo, P. 1984. Isolation and subregional mapping of a human cDNA clone detecting a common RFLP on chromosome 12. *Hum. Genet.* 68: 57-61.
- Barbi, G., Steinbach, P. and Vogel, W. 1984. Nonrandom distribution of methotrexate-induced aberrations on human chromosomes. Detection of further folic acid-sensitive fragile sites. *Hum. Genet.* 68: 290-294.
- Barker, D., Helms, C., Akots, G. and Donis-Keller, H. 1985. RFLP analysis of probes containing repetitive DNA using probe prehybridization. *Cytogenet. Cell Genet.* 40: 576A.

- Barker, D., Schafer, M. and White, R. 1984a. Restriction sites containing CpG show a higher frequency of polymorphism in human DNA. *Cell* 36: 131-138.
- Barker, D., Holm, T. and White R. 1984b. A locus on chromosome 11p with multiple restriction site polymorphisms. *Am. J. Hum. Genet.* 36: 1159-1171.
- Bates, G.P., Wainwright, B.J., Williamson, R. and Brown, S.D.M. 1986. Microdissection of and microcloning from the short arm of human chromosome 2. *Mol. Cell. Biol.* 6: 3826-3820.
- Bell, G.I., Selby, M.J. and Rutter, W.J. 1982. The highly polymorphic region near the human insulin gene is composed of simple tandemly repeating sequences. *Nature* 295: 31-35.
- Benton, W.D. and Davis, R.W. 1977. Screening lambda gt recombinant clones by hybridization to single plaques in situ. *Science* 196: 180-182.
- Berger, R., Bloomfield, C.D. and Sutherland, G.R. 1985. Report of the committee on chromosomal rearrangements in neoplasia and on fragile sites. *Human Gene Mapping 8, Helsinki Conference. Cytogenet. Cell Genet.* 40: 490-535.
- Birnboim, H.C. and Doly, J. 1979. A rapid alkaline extraction procedure for screening recombinant plasmid DNA. *Nucleic Acids Res.* 7: 1513-1523.
- Boettcher, B. 1972. Blood Group Antigens. In: *The Biochemical Genetics of Man*. Brock, D.J.H. and Mayo, O., eds. Academic Press, London and New York.
- Botstein, D., White, R.L., Skolnick, M. and Davis, R.W. 1980. Construction of a genetic linkage map in man using restriction fragment length polymorphisms. *Am. J. Hum. Genet.* 32: 314-331.

- Bouche, J.P. 1981. The effect of spermidine on endonuclease inhibition by agarose contaminants. *Anal. Biochem.* 115: 42-45.
- Boylan, K.B., Takahashi, N., Diamond, M., Hood, L.E. and Prusiner, S.B. 1987. DNA length polymorphism located 5' to the human myelin basic protein gene. *Am. J. Hum. Genet.* 40: 387-400.
- Breuning, M.H., Brunner, H., Saris, J.J., van Ommen, G.J.B., Reeders, S.T., Ijdo, J.W., Verwest, A. and Pearson, P.L. 1987. Improved early diagnosis of adult polycystic kidney disease with flanking DNA markers. *Lancet* ii: 1359-1361.
- Breuning, M.H., Saris, J.J., Wapenaar, M.C., den Dunnen, J.T., van Ommen, G.J.B. and Pearson, P.L. 1988. The isolation of DNA probes from chromosome 16 for the diagnosis of polycystic kidney disease. In: *Approaches to the Pathogenesis of Polycystic Kidney Disease*. Carone, F.A., ed. (In press).
- Buften, L., Mohandas, T.K., Magenis, R.E., Sheehy, R., Bestwick, R.K. and Litt, M. 1986. A highly polymorphic locus on chromosome 16q revealed by a probe from a chromosome-specific cosmid library. *Hum. Genet.* 74: 425-431.
- Buroker, N.E., Buften, L., Surti, U., Leppert, M., Kumlin, E., Sheehy, R., Magenis, R.E. and Litt, M. 1987a. A hypervariable region at the D19S11 locus. *Hum. Genet.* 76: 90-95.
- Buroker, N.E., Bestwick, R., Haight, G., Magenis, R.E. and Litt, M. 1987b. A hypervariable repeated sequence on human chromosome 1p36. *Hum. Genet.* 77: 175-181.
- Callen, D.F. 1986. A mouse-human hybrid cell panel for mapping human chromosome 16. *Ann. Genet.* 29: 235-239.



- Callen, D.F., Hyland, V.J., Baker, E., Fratini, A., Simmers, R.N., Mulley, J.C. and Sutherland, G.R. 1988a. Fine mapping of gene probes and anonymous DNA fragments to the long arm of chromosome 16. *Genomics* 2: 144-153.
- Callen, D.F., Hyland, V.J., Baker, E.G., Fratini, A., Gedeon, A.K., Mulley, J.C., Fernandez, K.E.W., Breuning, M.H. and Sutherland, G.R. 1988b. Mapping the short arm of human chromosome 16. (Submitted).
- Camerino, G., Mattei, M.G., Mattei, J.F., Jay, M. and Mandel, J.L. 1983. Close linkage of fragile X-mental retardation syndrome to haemophilia B and transmission through a normal male. *Nature* 306: 701-704.
- Capon, D.J., Chen, E.Y., Levinson, A.D., Seeburg, P.H. and Goeddel, D.V. 1983. Complete nucleotide sequences of the T24 human bladder carcinoma oncogene and its normal homologue. *Nature* 302: 33-37.
- Carle, G.F., Burke, D.T., Olson, M.V., Little, R. and Schlessinger, D. 1987. Analysis of a yeast artificial-chromosome (YAC) library containing cloned human genomic DNA. *Human Gene Mapping 9* (1987). *Cytogenet. Cell Genet.* 46: 590A.
- Carle, G.F., Frank, M. and Olson, M.V. 1986. Electrophoretic separations of large DNA molecules by periodic inversion of the electric field. *Science* 232: 65-68.
- Carlock, L.R., Skarecky, D., Dana, S.L. and Wasmuth, J.J. 1985. Deletion mapping of human chromosome 5 using chromosome-specific DNA probes. *Am. J. Hum. Genet.* 37: 839-852.
- Casadaban, M.J. and Cohen, S.N. 1980. Analysis of gene control signals by DNA fusion and cloning in *Escherichia coli*. *J. Mol. Biol.* 138: 179-207.

- Castiglione, C.M., Kidd, J.R., Tischfield, J.A., Stambrook, P.J.,
Murphy, P.D., Sparkes, R.A. and Kidd, K.K. 1985. Polymorphism and
linkage of APRT. Eighth International Workshop on Human Gene
Mapping. *Cytogenet. Cell Genet.* 40: 601A.
- Cavalli-Sforza, L.L. and Bodmer, W.F. 1971. *The Genetics of Human
Populations*. W.H. Freeman, San Francisco.
- Cavenee, W., Leach, R., Mohandas, T., Pearson, P. and White, R. 1984.
Isolation and regional localization of DNA segments revealing
polymorphic loci from human chromosome 13. *Am. J. Hum. Genet.* 36:
10-24.
- Chakravarti, A., Buetow, K.H., Antonarakis, S.E., Waber, P.G., Boehm,
C.D. and Kazazian, H.H. 1984. Nonuniform recombination within the
human β -globin gene cluster. *Am. J. Hum. Genet.* 36: 1239-1258.
- Collins, A.R.S., Downes, C.S. and Johnson, R.T. 1984. Introduction:
An integrated view of inhibited repair. In: *DNA repair and its
inhibition*. Collins, A.R.S., Downes, C.S. and Johnson, R.T., eds.
Nucleic Acids Symp. Ser. 13: 1-12.
- Collins, F.S. and Weissman, S.M. 1984. Directional cloning of DNA
fragments at a large distance from an initial probe: a circular-
ization method. *Proc. Natl. Acad. Sci. USA* 81: 6812-6816.
- Collins, F.S., Drumm, M.L., Cole, J.L., Lockwood, W.K., Vande Woude,
G.F. and Iannuzzi, M.C. 1987. Construction of a general human
chromosome jumping library, with application to cystic fibrosis.
Science 235: 1046-1049.
- Conneally, P.M. and Rivas, M.L. 1980. Linkage analysis in man. In:
Advances in Human Genetics. Harris, H. and Hirschhorn, K., eds.
Vol. 10: 209-266.

- Conneally, P.M., Edwards, J.H., Kidd, K.K., Lalouel, J.-M., Morton, N.E., Ott, J. and White, R. 1985. Report of the committee on methods of linkage analysis and reporting. *Human Gene Mapping 8* (1985). *Cytogenet. Cell Genet.* 40: 356-359.
- Cooper, D.N. and Schmidtke, J. 1986. Diagnosis of genetic disease using recombinant DNA. *Hum. Genet.* 73: 1-11.
- Cooper, D.N. and Schmidtke, J. 1987. Diagnosis of genetic disease using recombinant DNA. *Supplement. Hum. Genet.* 77: 66-75.
- Cooper, D.N., Smith, B.A., Cooke, H.J., Niemann, S. and Schmidtke, J. 1985. An estimate of unique DNA sequence heterozygosity in the human genome. *Hum. Genet.* 69: 201-205.
- Cox, D.R. and Gedde-Dahl, T. 1985. Report of the committee on the genetic constitution of chromosomes 13, 14, 15, and 16. *Cytogenet. Cell Genet.* 40: 206-241.
- Croci, G. 1983. BrdU-sensitive fragile site on the long arm of chromosome 16. *Am. J. Hum. Genet.* 35: 530-533.
- Cunningham, M.W. and Mundy, C.R. 1987. Labelling nucleic acids for hybridization. *Nature* 326: 723-724.
- Dalla Favera, R.C., Gallo, R.C., Giallongo, A. and Croce, C.M. 1982. Chromosomal localization of the human homolog (c-sis) of the simian sarcoma virus onc gene. *Science* 218: 686-688.
- Daniel, A. 1986. Clinical implications and classification of the constitutive fragile sites. *Am. J. Med. Genet.* 23: 419-427.
- Darras, B.T., Harper, J.F. and Francke, U. 1987. Prenatal diagnosis and detection of carriers with DNA probes in Duchenne's muscular dystrophy. *N. Engl. J. Med.* 316: 985-992.
- Davies, K.E. 1981. The application of DNA recombinant technology to the analysis of the human genome and genetic disease. *Hum. Genet.* 58: 351-357.

- Davies, K.E., Mandel, J.-L., Weissenbach, J. and Fellous, M. 1987.
Report of the committee on the genetic constitution of the X and Y
chromosomes. *Human Gene Mapping 9* (1987). *Cytogenet. Cell Genet.*
46: 277-315.
- Davies, K.E., Young, B.D., Ellis, R.G., Hill, M.E. and Williamson,
R.E. 1981. Cloning of a representative genomic library of the
human X chromosome after sorting by flow cytometry. *Nature* 293:
374-376.
- De Braekeleer, M., Smith, B. and Lin, C.C. 1985. Fragile sites and
structural rearrangements in cancer. *Hum. Genet.* 69: 112-116.
- Deisseroth, A., Nienhuis, A., Turner, P., Velez, R., Anderson, W.F.,
Ruddle, F., Lawrence, J. and Creagan, R. 1977. Localization of the
human α -globin structural gene to chromosome 16 in somatic cell
hybrids by molecular hybridization assay. *Cell* 12: 205-218.
- Dekaban, A. 1965. Persisting clone of cells with an abnormal chromosome
in a women previously irradiated. *J. Nucl. Med.* 6: 740-746.
- Djalali, M., Adolph, S., Steinbach, P., Winking, H. and Hameister, H.
1987. A comparative mapping study of fragile sites in the human and
murine genomes. *Hum. Genet.* 77: 157-162.
- Djalali, M., Barbi, G. and Steinbach, P. 1985. Folic acid sensitive
fragile sites are not limited to the human karyotype. Demonstration
of nonrandom gaps and breaks in the Persian vole *Ellobius lutescens*
Th. inducible by methotrexate, fluorodeoxyuridine, and aphidicolin.
Hum. Genet. 70: 183-185.
- Donis-Keller, H., Barker, D.F., Knowlton, R.G., Schumm, J.W., Braman,
J.C. and Green, P. 1986. Highly polymorphic RFLP probes as diagnostic
tools. *Cold Spring Harbor Symp. Quant. Biol.* 51: 317-324.

- Donis-Keller, H., Green, P., Helms, C., Cartinhour, S., Weiffenbach, B., Stephens, K., Keith, T.P., Bowden, D.W., Smith, D.R., Lander, E.S., Botstein, D., Akots, G., Rediker, K.S., Gravius, T., Brown, V.A., Rising, M.B., Parker, C., Powers, J.A., Watt, D.E., Kauffman, E.R., Bricker, A., Phipps, P., Muller-Kahle, H., Fulton, T.R., Ng, S., Schumm, J.W., Braman, J.C., Knowlton, R.G., Barker, D.F., Crooks, S.M., Lincoln, S.E., Daly, M.J. and Abrahamson, J. 1987. A Genetic Linkage Map of the Human Genome. *Cell* 51: 319-337.
- Drayna, D., Davies, K., Hartley, D., Mandel, J.L., Camerino, G., Williamson R. and White, R. 1984. Genetic mapping of the human X chromosome by using restriction fragment length polymorphisms. *Proc. Natl. Acad. Sci. USA* 81: 2836-2839.
- Dykes, D., Fondell, J., Watkins, P. and Polesky, H. 1986. The use of biotinylated DNA probes for detecting single copy human restriction fragment length polymorphisms separated by electrophoresis. *Electrophoresis* 7: 278-282.
- Emery, A.E.H. 1976. *Methodology in Medical Genetics. An Introduction to Statistical Methods.* Edinburgh, London and New York, Churchill Livingstone.
- Engelke, D.R., Hoener, P.A. and Collins, F.S. 1988. Direct sequencing of enzymatically amplified human genomic DNA. *Proc. Natl. Acad. Sci. USA* 85: 544-548.
- Erbe, R.W. and Wang, J.-C.C. 1982. Folate pathways in cells from fragile X syndrome patients and carriers. In: *Chemistry and Biology of Pteridines: proceedings of the Seventh International Symposium of Pteridines and Folic acid Derivatives.* Blair, J.A., ed. pp. 21-24. Walter DeGruyter and Co., Berlin.

- Fagerhol, M.K. and Cox, D.W. 1981. The PI polymorphism: Genetic, biochemical, and clinical aspects of human α_1 -antitrypsin. In: *Advances in Human Genetics*. Harris, M. and Hirschorn, K., eds. Vol. 11, pp. 1-62. Plenum Press, New York and London.
- Feder, J., Yen, L., Wijsman, E., Wang, L., Wilkens, L., Schroder, J., Spurr, N., Cann, H., Blumenberg, M. and Cavalli-Sforza, L.L. 1985. A systematic approach for detecting high-frequency restriction fragment polymorphisms using large genomic probes. *Am. J. Hum. Genet.* 37: 635-649.
- Feinberg, A.P. and Vogelstein, B. 1983. A technique for radiolabelling DNA restriction endonuclease fragments to high specific activity. *Anal. Biochem.* 132: 6-13.
- Filippi, G., Rinaldi, A., Archidiacono, N., Rocchi, M., Balazs, I. and Siniscalco, M. 1983. Linkage between G6PD and fragile X syndrome. *Am. J. Med. Genet.* 15: 113-119.
- Fischer, S.G. and Lerman, L.S. 1983. DNA fragments differing by single base pair substitutions are separated in denaturing gradient gels: Correspondence with melting theory. *Proc. Natl. Acad. Sci. USA* 80: 1579-1583.
- Fisher, J.H., Gusella, J.F. and Scoggin, C.H. 1984. Molecular hybridization under conditions of high stringency permits cloned DNA segments containing reiterated DNA sequences to be assigned to specific chromosomes. *Proc. Natl. Acad. Sci. USA* 81: 520-524.
- Ford, E.B. 1964. *Ecological Genetics*. John Wiley and Sons, New York.
- Forget, B.G. 1977. Nucleotide sequence of human β -globin messenger RNA. *Hemoglobin* 1: 879-881.
- Fratini, A., Baker, E.G., Callen, D.F., Hyland, V.J. and Sutherland, G.R. 1988a. ACHF249 (D22S14) detects a common PstI RFLP and maps at 22cen->22q13.1. *Nucleic Acids Res.* (Accepted for publication).

- Fratini, A., Baker, E.G., Callen, D.F., Reeders, S.T., Hyland, V.J. and Sutherland, G.R. 1988b. pACHF1.1 (D16S8) detects a common PvuII RFLP and maps at 16p13.3->16p13.11. *Nucleic Acids Res.* (Accepted for publication).
- Fratini, A., Baker, E.G., Callen, D.F., Hyland, V.J. and Sutherland, G.R. 1988c. RsaI and TaqI RFLPs for pACHF3.5 (D16S10). *Nucleic Acids Res.* (Accepted for publication).
- Fratini, A., Simmers, R.N., Callen, D.F., Hyland, V.J., Tischfield, J.A., Stambrook, P.J. and Sutherland, G.R. 1986. A new location for the human adenine phosphoribosyltransferase gene (APRT) distal to the haptoglobin (HP) and fra(16)(q23) (FRA16D) loci. *Cytogenet. Cell Genet.* 43: 10-13.
- Gemmill, R.M., Coyle-Morris, J.F., McPeck, F.D., Ware-Uribe, L.F. and Hecht, F. 1987. Construction of long-range restriction maps in human DNA using pulsed field gel electrophoresis. *Gene Anal. Techn.* 4: 119-131.
- Giraud, F., Ayme, S., Mattei, J.F. and Mattei, M.G. 1976. Constitutional chromosomal breakage. *Hum. Genet.* 34: 125-136.
- Glover, T.W. 1981. FUDR induction of the X chromosome fragile site: Evidence for the mechanism of folic acid and thymidine inhibition. *Am. J. Hum. Genet.* 33: 234-242.
- Glover, T.W. 1985. Biochemistry of fragile site expression. In: *Fragile Sites on Human Chromosomes*. Sutherland, G.R. and Hecht, F., eds. pp. 80-94. New York: Oxford Univ. Press.
- Glover, T.W., Berger, C., Coyle, J. and Echo, B. 1984. DNA polymerase α inhibition by aphidicolin induces gaps and breaks at common fragile sites in human chromosomes. *Hum. Genet.* 67: 136-142.

- Glover, T.W., Coyle-Morris, J., Pearce-Birge, L., Berger, C. and Gemmill, R.M. 1986. DNA demethylation induced by 5-azacytidine does not affect fragile X expression. *Am. J. Hum. Genet.* 38: 309-318.
- Gollin, S.M., Bock, H.-G.O., Caskey, C.T. and Ledbetter, D.H. 1985a. A new family with fra(10)(q25): Spontaneous expression and 100% expression with 100 μ M BrdU. *Am. J. Med. Genet.* 21: 643-648.
- Gollin, S.M., Holmquist, G.P., and Ledbetter, D.H. 1985b. Fra(10)(q25): The BrdU effect is substitution-dependent. *Am. J. Hum. Genet.* 37: 208-214.
- Goodbourn, S.E.Y., Higgs, D.R., Clegg, J.B. and Weatherall, D.J. 1983. Molecular basis of length polymorphism in the human ξ -globin gene complex. *Proc. Natl. Acad. Sci. USA* 80: 5022-5026.
- Goulian, M., Bleile, B. and Tseng, B.Y. 1980. Methotrexate-induced misincorporation of uracil into DNA. *Proc. Natl. Acad. Sci. USA* 77: 1956-1960.
- Grafstrom, R.H., Tseng, B.Y. and Goulian, M. 1978. The incorporation of uracil into animal cell DNA in vitro. *Cell* 15: 131-140.
- Grodzicker, T., Williams, J., Sharp, P. and Sambrook, J. 1974. Physical mapping of temperature-sensitive mutations of adenoviruses. *Cold Spring Harbor Symp. Quant. Biol.* 39: 439-446.
- Gusella, J.F. 1986. DNA polymorphism and human disease. *Ann. Rev. Biochem.* 55: 831-54.
- Gusella, J.F., Keys, C., Varsanyi-Breiner, A., Kao, F.-T., Jones, C., Puck, T.T. and Housman, D. 1980. Isolation and localization of DNA segments from specific human chromosomes. *Proc. Natl. Acad. USA* 77: 2829-2833.

- Gusella, J.F., Wexler, N.S., Conneally P.M., Naylor, S.L., Anderson, M.A. Tanzi, R.E., Watkins, P.G., Ottina, K., Wallace, M.R., Sakaguchi, A.Y., Young, A.B., Shoulson, I., Bonilla, E. and Martin, J.B. 1983. A polymorphic DNA marker genetically linked to Huntington's disease. *Nature* 306: 234-238.
- Hagerman, P.J. 1984. The relationship between uracil incorporation into DNA and the expression of fragile sites in human chromosomes. *Am. J. Med. Genet.* 19: 407-409.
- Harper, M.E. and Saunders, G.F. 1981. Localization of single-copy DNA sequences on G-banded human chromosomes by *in situ* hybridization. *Chromosoma* 83: 431-439.
- Harris, H. 1969. Enzyme and protein polymorphism in human populations. *Brit. Med. Bull.* 25: 5-13.
- Harris, H. 1980. *The Principles of Human Biochemical Genetics*. Elsevier/North-Holland Biomedical Press, Amsterdam, New York and Oxford.
- Harris, H. and Hopkinson, D.A. 1978. *Handbook of Enzyme Electrophoresis in Human Genetics*. North-Holland, Amsterdam, New York and Oxford.
- Harris, P., Lalonde, M., Stroh, H., Bruns, G., Flint, A. and Latt, S.A. 1987. Construction of a chromosome 16-enriched phage library and characterization of several DNA segments from 16p. *Hum. Genet.* 77: 95-103.
- Harrison, C.J., Jack, E.M., Allen, T.D. and Harris, R. 1983. The fragile X: a scanning electron microscope study. *J. Med. Genet.* 20: 280-285.
- Harvey, J., Judge, C. and Wiener, S. 1977. Familial X-linked mental retardation with an X chromosome abnormality. *J. Med. Genet.* 14: 46-50.

- Hecht, F. and Sutherland, G.R. 1984. Fragile sites and cancer breakpoints. *Cancer Genet. Cytogenet.* 12: 179-181.
- Helentjaris, T. and Gesteland, R. 1983. Evaluation of random cDNA clones as probes for human restriction fragment polymorphisms. *J. Mol. Appl. Genet.* 2: 237-247.
- Higgs, D.R., Goodbourn, S.E.Y., Wainscoat, J.S., Clegg, J.B. and Weatherall, D.J. 1981. Highly variable regions of DNA flank the human globin genes. *Nucleic Acids Res.* 9: 4213-4224.
- Hill, W.G. 1974. Estimation of linkage disequilibrium in randomly mating populations. 33: 229-239.
- Hofker, M.H., Bergen, A.A.B., Skraastad, M.I., Carpenter, N.J., Veenema, H., Conner, J.M., Bakker, E., van Ommen, G.J.B. and Pearson, P.L. 1987a. Efficient isolation of X chromosome specific single-copy probes from a cosmid library of a human X / hamster hybrid cell line: mapping of new probes close to the locus for X linked mental retardation. *Am. J. Hum. Genet.* 40: 312-328.
- Hofker, M.H., Breuning, M.H., Bakker, E., van Ommen, G.J.B. and Pearson, P.L. 1987b. An anonymous single copy chromosome 22 clone, D22S10 (22c1-18) identifies an RFLP with PstI. *Nucleic Acids Res.* 13: 7167.
- Hofker, M.H., Skraastad, M.I., Bergen, A.A.B., Wapenaar, M.C., Bakker, E., Millingtonward, A., Van Ommen, G.J.B. and Pearson, P.L. 1986. The X chromosome shows less genetic variation at restriction sites than the autosomes. *Am. J. Hum. Genet.* 39: 438-451.
- Holden, J.J.A., Wang, H. and White, B.N. 1984. The fragile-X syndrome, IV. Progress towards the identification of linked restriction fragment length variants (RFLVs). *Am. J. Med. Genet.* 17: 259-273.

- Howard-Peebles, P.N. and Pryor, J. 1981. Fragile sites in human chromosomes. I. The effect of methionine on the Xq fragile site. *Clin. Genet.* 19: 228-232.
- Hsu, T.C. and Somers, C.E. 1961. Effects of 5-bromodeoxyuridine on mammalian chromosomes. *Proc. Natl. Acad. Sci. USA* 47: 396-403.
- Human Gene Mapping 7. 1984. Los Angeles Conference (1983). International Workshop on Human Gene Mapping. *Cytogenet. Cell Genet.* 37: 1-666.
- Human Gene Mapping 8. 1985. Helsinki Conference (1985). International Workshop on Human Gene Mapping. *Cytogenet. Cell Genet.* 40: 1-832.
- Hunt, P.A. and Burgoyne, P.S. 1987. A tissue-specific fragile site associated with the sex reversed (Sxr) mutation in the mouse. *Chromosoma* 96: 67-71.
- Hunter, R.L. and Market, C.L. 1957. Histochemical demonstration of enzymes separated by zone electrophoresis in starch gels. *Science* 125: 1294-1295.
- Hutchinson, C. III., Newbold, J., Potter, S. and Edgell, M. 1974. Maternal inheritance of mammalian mitochondrial DNA. *Nature* 251: 536.
- Hyland, V.J., Fernandez, K.E.W., Callen, D.F., MacKinnon, R.N., Baker, E.G. and Sutherland, G.R. (1989). Anonymous DNA probes to specific intervals of human chromosomes 16 and X. *Genomics* (submitted).
- Hyland, V.J., Grist, S., Callen, D.F. and Sutherland, G.R. 1988a. Anonymous DNA probes to human chromosome 16 derived from a flow-purified library. *Am. J. Hum. Genet.* 42: 373-379.
- Hyland, V.J., Grist, S. and Sutherland, G.R. 1988b. Restriction fragment length polymorphisms detected by anonymous DNA probes mapped to defined intervals of human chromosome 16. *Hum. Genet.* (In Press).

- Ingram, V.M. 1957. Gene mutations in human haemoglobin: the chemical difference between normal and sickle cell haemoglobin. *Nature* 180: 326-328.
- ISCN, 1985: An International System for Human Cytogenetic Nomenclature. Harnden, D.G. and Klinger, H.P, eds. Published in collaboration with *Cytogenet. Cell Genet.* (Karger, Basel), 1985.
- Izakovic, V. 1984. Homozygosity for fragile site at 17p12 in a 28 year old healthy man. *Hum. Genet.* 68: 340-341.
- Jacky, P.B. and Sutherland, G.R. 1983. Thymidylate synthetase inhibitors and fragile site expression in lymphocytes. *Am. J. Hum. Genet.* 35: 1276-1283.
- Jeffreys, A.J. 1979. DNA sequence variants in γ -, α -, δ -, and β -globin genes of man. *Cell* 18: 1-10.
- Jeffreys, A.J., Wilson, V. and Thein, S.L. 1985a. Hypervariable 'minisatellite' regions in human DNA. *Nature* 314: 67-73.
- Jeffreys, A.J., Wilson, V. and Thein, S.L. 1985b. Individual-specific 'fingerprints' of human DNA. *Nature* 316: 76-79.
- Jeffreys, A.J., Wilson, V., Thein, S.L., Weatherall, D.J. and Ponder, B.A.J. 1986. DNA 'fingerprints' and segregation analysis of multiple markers in human pedigrees. *Am. J. Hum. Genet.* 39: 11-24.
- Jelinek, W.R. and Schmid, C.W. 1982. Repetitive sequences in eukaryotic DNA and their expression. *Ann. Rev. Biochem.* 51: 813-844.
- Jelinek, W.R., Toomey, T.P., Leinwand, L., Duncan, C.H., Biro, P.A., Choudary, P.V., Weissman, S.M., Rubin, C.M., Houck, C.M., Deininger, P.L. and Schmid, C.W. 1980. Ubiquitous, interspersed repeated sequences in mammalian genomes. *Proc. Natl. Acad. Sci. USA* 77: 1398-1402.

- Julier, C. and White, R. 1988. Detection of a NotI polymorphism with the pmetH probe by pulsed-field gel electrophoresis. *Am. J. Hum. Genet.* 42: 45-48.
- Kaiser, R., Weber, J., Grzeschik, K.-H., Edstrom, J.E., Driesel, A., Zengerling, S., Buchwald, M., Tsui, C. and Olek, K. 1987. Microdissection and microcloning of the long arm of human chromosome 7. *Mol. Biol. Rep.* 12: 3-6.
- Kan, Y.W. and Dozy, A.M. 1978a. Polymorphism of DNA sequence adjacent to human β -globin structural gene: relationship to sickle mutation. *Proc. Natl. Acad. Sci. USA* 75: 5631-5635.
- Kan, Y.W. and Dozy, A.M. 1978b. Antenatal diagnosis of sickle-cell anemia by DNA analysis of amniotic-fluid cells. *Lancet* ii: 910-912.
- Kao, F., Hartz, J.A., Law, M.L. and Davidson, J.A. 1982. Isolation and chromosomal localization of unique DNA sequences from a human genomic library. *Proc. Natl. Acad. Sci. USA* 79: 865-869.
- Keith, T., Green, P., Reeders, S.T., Brown, V.A., Phipps, P., Bricker, A., Knowlton, R., Nelson, C. and Donis-Keller, H. 1987. A linkage map of chromosome 16 with 41 RFLP markers. *Human Gene Mapping 9* (1987). *Cytogenet. Cell Genet.* 46: 638A.
- Kessler, C. and Holtke, H.J. 1986. Specificity of restriction endonucleases and methylases - a review. *Gene* 47: 1-153.
- Kidd, V.J., Wallace, R.B., Itakura, K. and Woo, S.L.C. 1983. α_1 -antitrypsin deficiency detection by direct analysis of the mutation in the gene. *Nature* 304: 230-234.
- Knott, T.J., Wallis, S.C., Pease, R.J., Powell, L.M. and Scott, J. 1986. A hypervariable region 3' to the human apolipoprotein B gene. *Nucleic Acids Res.* 14: 9215-9216.

- Knowlton, R.G., Cohen-Haguenaer, O., Van Cong, N., Frezal, J., Brown, V.A., Barker, D., Braman, J.C., Schumm, J.W., Tsui, L.-C., Bruchwald, M. and Donis-Keller, H. 1985. A polymorphic DNA marker linked to cystic fibrosis is located on chromosome 7. *Nature* 318: 381-382.
- Koeffler, H.P., Sparkes, R.S., Stang, H. and Mohandas, T. 1981. Regional assignment of genes for human α -globin and phosphoglycolate phosphatase to the short arm of chromosome 16. *Proc. Natl. Acad. Sci. USA* 78: 7015-7018.
- Kosambi, D.D. 1944. The estimation of map distance from recombination values. *Ann. Eugen.* 12: 172-175.
- Krawczun, M.S., Jenkins, E.J. and Brown, W.T. 1985. Analysis of the fragile-X chromosome: localization and detection of the fragile site in high resolution preparations. *Hum. Genet.* 69: 209-211.
- Kreitmand, M. and Aguade, M. 1986. Genetic uniformity in two populations of *Drosophila melanogaster* as revealed by four cutter hybridization. *Proc. Natl. Acad. Sci. USA* 83: 3562-3566.
- Krumdieck, C.L. and Howard-Peebles, P.N. 1983. On the nature of folic acid sensitive fragile sites on human chromosomes: an hypothesis. *Am. J. Med. Genet.* 16: 23-28.
- Kunkel, L.M., Monaco, A.P., Middlesworth, W., Ochs, H.D. and Latt, S.A. 1985. Specific cloning of DNA fragments absent from the DNA of a male patient with an X chromosome deletion. *Proc. Natl. Acad. Sci. USA* 82: 4778-4782.
- Landsteiner, K. 1900. Zur Kenntnis der antifermentation, lytischen und agglutinieren den wirkungen des Blutserums und der lympe. *Zbl. Bakt.* 27: 357-362.
- Lange, K. and Boehnke, M. 1982. How many polymorphic genes will it take to span the human genome? *Am. J. Hum. Genet.* 34: 842-845.

- Lathrop, G.M., Leppert, M., Nakamura, Y., O'Connell, P., Litt, M., Maslen, S., Cartwright, P., Lalouel, J.M. and White, R. 1987. Primary genetic linkage map of chromosome 16. *Human Gene Mapping 9* (1987). *Cytogenet. Cell Genet.* 46: 643A.
- Leach, R., DeMars, D., Hasstedt, S. and White, R. 1986. Construction of a map of the short arm of chromosome 6. *Proc. Natl. Acad. Sci. USA* 83: 3909-3913.
- LeBeau, M.M. and Rowley, J.T. 1984. Heritable fragile sites in cancer. *Nature* 308: 607-608.
- Ledbetter, D.H., Airhart, S.D. and Nussbaum, R.L. 1986a. Caffeine enhances fragile (X) expression in somatic cell hybrids. *Am. J. Med. Genet.* 23: 445-456.
- Ledbetter, D.H., Ledbetter, S.A. and Nussbaum, R.L. 1986b. Implications of fragile X expression in normal males for the nature of the mutation. *Nature* 324: 161-163.
- Lejeune, J., Dutrillaux, B., Lafourcade, J., Berger, R., Abonyi, D. and Rethore, M.O. 1968. Endoreduplication selective du bras long du chromosome 2 chez un femme et sa fille. *C.R. Acad. Sci. (Paris)* 266: 24-26.
- Leppert, M., Cavenee, W., Callahan, P., Holm, T., O'Connell, P., Thompson, K., Lathrop, G.M., Lalouel, J.-M. and White, R. 1986. A primary genetic linkage map of chromosome 13q. *Am. J. Hum. Genet.* 39: 425-427.
- Lewontin, R.C. 1967. An estimate of average heterozygosity in man. *Am. J. Hum. Genet.* 19: 681-685.
- Li, N. and Zhou, X. 1985. Human chromosome hot points. IV. Uridine-induced hot-point breaks at 3p14 and 16q23-24 and increased expression of fragile site Xq27 in folate-free medium. *Hum. Genet.* 71: 363-365.

- Li, X., Yan, Z. and Zhou, X. 1986a. The effect of 1- β -D-arabinofuranosyl-cytosine on the expression of the common fragile site at 3p14. *Hum. Genet.* 74: 444-446.
- Li, N., Wu, Y. and Zhou, X. 1986b. Human chromosome hot points V. The effect of four nucleosides on chromosomes in folate free medium. *Hum. Genet.* 74: 101-103.
- Lin, S.J., Figueiredo, C., Sciorra, L.J. and Lee, M.L. 1987. Study of human chromosome V: The effects of thymidine concentration and timing on the expression of uridine-induced constitutive fragile sites. *Hum. Genet.* 76: 173-175.
- Litt, M. and White, R. 1985. A highly polymorphic locus in human DNA revealed by cosmid-derived probes. *Proc. Natl. Acad. Sci. USA* 82: 6206-6210.
- Litt, M., Sheehy, R., Bruns, G.A. and Magenis, R.E. 1986. A polymorphic locus on the long arm of chromosome 20 defined by two probes from a single cosmid. *Hum. Genet.* 73: 340-345.
- Loukopoulos, D. 1985. Prenatal diagnosis of thalassemia and of the hemoglobinopathies: a review. *Hemoglobin* 9: 435-459.
- Lowe, J.B. 1986. Clinical applications of gene probes in human genetic disease, malignancy, and infectious disease. *Clin. Chim. Acta.* 157: 1-32.
- Lubs, H.A. 1969. A marker X chromosome. *Am. J. Hum. Genet.* 21: 231-244.
- Lui, P., Hildebrand, G.E., Meincke, L., Siciliano, M.J. and Stallings, R.L. 1987. Isolation of human chromosome 16 DNA sequence probes. *Human Gene Mapping 9 (1987). Cytogenet. Cell Genet.* 46: 652A.
- Magenis, E. and Chamberlin, J. 1979. Location of fragile site: 16q22.00. *Cytogenet. Cell Genet.* 25: 180.

- Magenis, R.E., Hecht, F. and Lovrien. 1970. Heritable fragile site on chromosome 16: probable localization of haptoglobin locus in man. *Science* 170: 85-87.
- Maniatis, T., Fritsch, E.F. and Sambrook, J. 1982. *Molecular cloning: a laboratory manual*. Cold Spring Harbor Laboratory. Cold Spring Harbor, NY.
- Maniatis, T., Hardison, R.C., Lacy, E., Lauer, J., O'Connell, C., Quon, D., Sim, G.K. and Efstratiadis, A. 1978. The isolation of structural genes from libraries of eucaryotic DNA. *Cell* 15: 687-701.
- Mattei, M.G., Baeteman, M.A., Heilig, R., Oberle, I., Davies, K., Mandel, J.L. and Mattei, J.F. 1985. Localization by *in situ* hybridization of the coagulation factor IX gene and two polymorphic DNA probes with respect to fragile X site. *Hum. Genet.* 69: 327-331.
- McKusick, V.A. 1986. *Mendelian Inheritance in Man*. Seventh Edition. The John Hopkins University Press, Baltimore and London.
- Melton, D.A., Krieg, P.A., Rebagliati, M.R., Maniatis, T., Zinn, K. and Green, M.R. 1984. Efficient *in vitro* synthesis of biologically active RNA and RNA hybridization probes from plasmids containing a bacteriophage SP6 promoter. *Nucleic Acids Res.* 12: 7035-7036.
- Mendelsohn, M.L., Mayall, B.H., Bogart, E., Moore, D.H. and Perry, B.H. 1973. DNA content and DNA-based centromeric index of the 24 human chromosomes. *Science* 179: 1126-1129.
- Miro, R., Clemente, I.C., Fuster, C. and Egozcue, J. 1987. Fragile sites, chromosome evolution, and human neoplasia. *Hum. Genet.* 75: 345-349.
- Mixon, J.C. and Dev, V.G. 1983. Fragile X expression is decreased by 5-azacytidine and S-adenosylhomocysteine. *Am. J. Hum. Genet.* 35: 1270-1275.

- Morton, N.E. 1955. Sequential tests for the detection of linkage. *Am. J. Hum. Genet.* 7: 277-318.
- Mourant, A.E., Kopec, A.G. and Domaniewska-Sobvzak, K. 1978. *Blood Groups and Diseases: A Study of Associations of Diseases with Blood Groups and other Polymorphisms.* Oxford University Press.
- Mulley, J.C. 1985a. Genetic Marker Studies in Humans. Ph.D. dissertation, University of Adelaide.
- Mulley, J.C. 1985b. Linkage relationships of fragile sites. In: *Fragile Sites on Human Chromosomes.* Sutherland, G.R. and Hecht, F., eds. New York: Oxford University Press.
- Mulley, J.C., Gedeon, A.K., Thorn, K.A., Bates, L.J. and Sutherland, G.R. 1987. Linkage and genetic counselling for the fragile X using DNA probes 52A, F9, DX13, and ST14. *Am. J. Med. Genet.* 27: 435-448.
- Mulley, J.C., Hay, J., Sheffield, L.J. and Sutherland, G.R. 1983a. Regional localization for HLA by recombination with a fragile site at 6p23. *Am. J. Hum. Genet.* 35: 1284-1288.
- Mulley, J.C., Nicholls, C. and Sutherland, G.R. 1983b. A search for linkage in families with fragile sites. *Hum. Genet.* 65: 79-81.
- Mulley, J.C., Hyland, V.J., Fratini, A., Bates, L.J., Baker, E.G., Gedeon, A.K., Callen, D.F. and Sutherland, G.R. 1988. A linkage group with FRA16B (The fragile site at 16q22.1). (Submitted).
- Mulligan, L.M., Phillips, M.A., Forster-Gibson, C.J., Beckett, J., Partington, M.W., Simpson, N.E., Holden, J.J.A. and White, B.N. 1985. Genetic mapping of DNA segments relative to the locus for the fragile-X syndrome at Xq27.3. *Am. J. Hum. Genet.* 37: 463-472.
- Murray, J.C., Shiang, R., Carlock, L.R., Smith, M. and Buetow, K.H. 1987. Rapid RFLP screening procedure identifies new polymorphisms at albumin and alcohol dehydrogenase loci. *Hum. Genet.* 76: 274-277.

- Murray, J.M., Davies, K.E., Harper, P.S., Meredith, L., Mueller, C.R. and Williamson, R. 1982. Linkage relationship of a cloned DNA sequence on the short arm of the X chromosome to Duchenne muscular dystrophy. *Nature* 300: 542-544.
- Murray, N.E., Brammar, W.J. and Murray, K. 1977. Lambdoid phages that simplify the recovery of in vitro recombinants. *Mol. Gen. Genet.* 150: 53-61.
- Myers, R.M., Lumelsky, N., Lerman, L.S. and Maniatis, T. 1985. Detection of single base substitutions in total genomic DNA. *Nature* 313: 495-498.
- Nakamura, Y., Julier, C., Wolff, R., Holm, T., O'Connell, P.O., Leppert, M. and White, R. 1987a. Characterization of a human 'midisatellite' sequence. *Nucleic Acids Res.* 15: 2537-2547.
- Nakamura, Y., Leppert, M., O'Connell, P., Wolff, R., Holm, T., Culver, M., Martin, C., Fujimoto, E., Hoff, M., Kumlin, E. and White R. 1987b. Variable number of tandem repeat (VNTR) markers for human gene mapping. *Science* 235: 1616-1622.
- Nathans, D. and Smith, H.O. 1975. Restriction endonuclease in the analysis and restructuring of DNA molecules. *Ann. Rev. Biochem.* 44: 273-290.
- Neel, J.V. 1984. A revised estimate of the amount of genetic variation in human proteins: implications for the distribution of DNA polymorphisms. *Am. J. Hum. Genet.* 36: 1135-1148.
- Nei, M. 1975. *Molecular population genetics and evolution*. North Holland Publishing Co., Amsterdam.
- Neve, R.L., Bruns, G.A.P., Dryja, T.P. and Kurnit, D.M. 1983. Retrieval of human DNA from rodent-human genomic libraries by a recombination process. *Gene* 23: 343-354.

- Nguyen, C., Pontarotti, P., Birnbaum, D., Chimini, G., Rey, J.A., Mattei, J.-F. and Jordan, B.R. 1987. Large scale physical mapping in the q27 region of the human X chromosome: the coagulation factor IX gene and the mcf.2 transforming sequence are separated by at most 270 kilobase pairs and are surrounded by several 'HTF' islands. *EMBO J.* 6: 3285-3289.
- Nussbaum, D., Crowder, W., Nyhan, W. and Caskey, C.T. 1983a. A three-allele restriction fragment length polymorphism at the hypoxanthine phosphoribosyltransferase locus in man. *Proc. Natl. Acad. Sci. USA.* 80: 4035-4039.
- Nussbaum, R.L., Airhart, S.D. and Ledbetter, D.H. 1983b. Expression of the fragile (X) chromosome in an interspecific somatic cell hybrid. *Hum. Genet.* 64: 148-150
- Nussbaum, R.L. and Ledbetter, D.H. 1986. Fragile X syndrome: a unique mutation in man. *Ann. Rev. Genet.* 20: 109-45.
- Nussbaum, R.L., Airhart, S.D. and Ledbetter, D.H. 1986a. A rodent-human hybrid containing Xq24-qter translocation to a hamster chromosome expresses the Xq27 folate sensitive fragile site. *Am. J. Med. Genet.* 23: 457-466.
- Nussbaum, R.L., Airhart, S.D. and Ledbetter, D.H. 1986b. Recombination and amplification of pyrimidine-rich sequences may be responsible for initiation and progression of the Xq27 fragile site: a hypothesis. *Am. J. Med. Genet.* 23: 715-722.
- Nussbaum, R.L., Walmsley, R.M., Lesko, J.G., Airhart, S.D. and Ledbetter, D.H. 1985. Thymidylate synthase-deficient Chinese hamster cells: a selection system for human chromosome 18 and experimental system for the study of thymidylate synthase regulation and fragile X expression. *Am. J. Hum. Genet.* 37: 1192-1205.

- O'Brien, S.J. 1973. On estimating functional gene number in eukaryotes. *Nature* 242: 52-54.
- Oberle, I., Heilig, R., Moisan, J.P., Kloepfer, C., Mattei, M.G.,
Mattei, J.F., Boue, J., Froster-Iskenius, U., Jacobs, P.A.,
Lathrop, G.M., Lalouel, J.M. and Mandel, J.L. 1986. Genetic
analysis of the fragile-X mental retardation syndrome with two
flanking polymorphic DNA markers. *Proc. Natl. Acad. Sci. USA* 83:
1016-1020.
- Oberle, I., Mandel, J.L., Boue, J., Mattei, M.G. and Mattei, J.F.
1985. Polymorphic DNA markers in prenatal diagnosis of fragile X
syndrome. *Lancet* i: 871.
- Orkin, S.H., Alter, B.P., Altay, C., Mahoney, M.J., Lazarus, H.,
Hobbins, J.C. and Nathans, D.G. 1978. Application of endonuclease
mapping to the analysis and prenatal diagnosis of thalassemias
caused by globin-gene deletion. *N. Engl. J. Med.* 299: 31-35.
- Ott, J. 1974. Estimation of recombination fraction in human pedigrees:
efficient computation of the likelihood for human linkage studies.
Am. J. Hum. Genet. 26: 588-597.
- Ott, J. 1976. A computer program for linkage analysis of general human
pedigrees. *Am. J. Hum. Genet.* 28: 528-529.
- Ott, J. 1986. *Analysis of Genetic Linkage in Human Families*. John
Hopkins University Press, Baltimore.
- Patterson, M., Kenwick, S., Thibodeau, S., Faulk, K., Mattei, M.G.,
Mattei, J.-F. and Davies, K.E. 1987. Mapping of DNA markers close
to the fragile site on the human X chromosome at Xq27.3. *Nucleic
Acids Res.* 15: 2639-2651.
- Pauling, L., Itano, H.A., Singer, S.J. and Wells, I.C. 1949. Sickle
cell anemia, a molecular disease. *Science* 110: 543-548.

- Pearson, P.L., Kidd, K.K. and Willard, H.F. 1987. Report of the committee on Human Gene Mapping by recombinant DNA techniques, Human Gene Mapping 9 (1987). Cytogenet. Cell Genet. 46: 390-566.
- Petes, T.K. and Botstein, D. 1977. Simple Mendelian inheritance of the reiterated ribosomal DNA of yeast. Proc. Natl. Acad. Sci. USA 74: 5091-5095.
- Pingoud, A. 1985. Spermidine increases the accuracy of type II restriction endonucleases: Suppression of cleavage at degenerate, non-symmetrical sites. Eur. J. Biochem. 147: 105-109.
- Popovich, B.W., Rosenblatt, D.S., Cooper, B.A. and Vekemans, M. 1983. Intracellular folate distribution in cultured fibroblasts from patients with the fragile X syndrome. Am. J. Hum. Genet. 35: 869-878.
- Porfirio, B., Dallapiccola, B. and Terrenato, L. 1987. Breakpoint distribution in constitutional chromosomal rearrangements with respect to fragile sites. Ann. Hum. Genet. 51: 329-336.
- Porteous, D.J. 1986. Rapid isolation and characterization of hybridization selected recombinants from lambda genomic libraries. Anal. Biochem. 159: 17-23.
- Poustka, A. and Lehrach, H. 1986. Jumping libraries and linking libraries: the next generation of molecular tools in mammalian genetics. Trends Genet. 2: 174-179.
- Poustka, A., Pohl, T.M., Barlow, D.P., Frischauf, A.-M. and Lehrach, H. 1987. Construction and use of human chromosome jumping libraries from NotI-digested DNA. Nature 325: 353-355.
- Purrello, M., Alhadeff, B., Esposito, D., Szabo, P., Rocchi, M., Truett, M., Masiarz, F. and Siniscalco, M. 1985. The human genes for hemophilia A and hemophilia B flank the X chromosome fragile site at Xq27.3. EMBO J. 4: 725-729.

- Puspurs, A.H., Baker, E., Callen, D.F., Fratini, A. and Sutherland, G.R. 1988. Translocation breakpoint in t(11;14) in B-Cell Leukemia is not at the rare fragile site at 11q13.3. *Cancer Genet. Cytogenet.* 31: 25-30.
- Race, R.R. and Sanger, R. 1975. *Blood Groups in Man*. Blackwell Scientific Publications. Oxford, London, Edinburgh and Melbourne.
- Reeders, S.T., Breuning, M.H., Davies, K.E., Nicholls, R.D., Jarman, A.P., Higgs, D.R., Pearson, P.L. and Weatherall, D.J. 1985. A highly polymorphic DNA marker linked to adult polycystic kidney disease on chromosome 16. *Nature* 317: 542-544.
- Reeders, S.T., Zerres, K., Gal, A., Hogenkamp, T., Propping, P., Schmidt, W., Waldherr, R., Dolata, M.M., Davies, K.E. and Weatherall, D.J. 1986. Prenatal diagnosis of autosomal dominant polycystic kidney disease with a DNA probe. *Lancet* ii: 6-8.
- Rees, A., Shoulders, C.C., Stocks, J., Galton, D.J. and Baralle, F.E. 1983. DNA polymorphisms adjacent to the human Apoprotein A-I gene: Relation to hypertriglyceridaemia. *Lancet* i: 444-446.
- Renwick, J.H. 1969. Progress in mapping human autosomes. *Br. Med. Bull.* 25: 65-73.
- Renwick, J.H. 1971. The mapping of human chromosomes. *Ann. Rev. Genet.* 5: 81-120.
- Rigby, P.W., Dieckman, M., Rhodes, C. and Berg, P. 1977. Labelling deoxyribonucleic acid to high specific activity *in vitro* by nick translation with DNA polymerase I. *J. Mol. Biol.* 113: 237-251.
- Roberts, J.J. 1984. Mechanisms of potentiation by caffeine of genotoxic damage induced by physical and chemical agents. In: *DNA repair and its inhibition*. Collins, A., Downes, C.S. and Johnson, R.T., eds. IRL Press, Oxford.

- Robinson, T.J. and Elder, F.F.B. 1987. Multiple common fragile sites are expressed in the genome of the laboratory rat. *Chromosoma* 96: 45-49.
- Ropers, H.H., Gedde-Dahl, T. and Cox, D.W. 1987. Report of the committee on the genetic constitution of chromosomes 13, 14, 15 and 16, *Human Gene Mapping 9* (1987). *Cytogenet. Cell Genet.* 46: 213-241.
- Rotwein, P.S., Chirgwin, J., Province, M., Knowler, W.C., Pettitt, D.J., Cordell, B., Goodman, H.M. and Permutt, M.A. 1983. Polymorphism in the 5' flanking region of the human insulin gene: a genetic marker for non-insulin-dependent diabetes. *N. Engl. J. Med.* 308: 65-71.
- Royer-Pokora, B., Kunkel, L.M., Monaco, A.P., Goff, S.C., Newburger, P.E., Baehner, R.L., Cole, F.S., Curnutte, J.T. and Orkin, S.H. 1986. Cloning the gene for an inherited human disorder - chronic granulomatous disease - on the basis of its chromosomal location *Nature* 322: 32-38.
- Royle, N.J., Clarkson, R., Wong, Z. and Jeffreys, A.J. 1987. Preferential localisation of hypervariable minisatellites near human telomeres. *Human Gene Mapping 9* (1987). *Cytogenet. Cell Genet.* 46: 685A.
- Rubin, C.M., Houck, C.M., Deininger, P.L., Friedemann, T. and Schmid, C.W. 1980. Partial nucleotide sequence of the 300-nucleotide interspersed repeated human DNA sequences. *Nature* 284: 372-374.
- Ruddle, F.H. 1973. Linkage analysis in man by somatic cell genetics. *Nature* 242: 165-169.

- Scheffer, H., van der Lelie, D., Aanstoot, G.H., Goor, N., Nienhaus, A.J., van der Hout, A.H., Pearson, P.L. and Buys, C.H.C.M. 1986. A straightforward approach to isolate DNA sequences with potential linkage to the retinoblastoma locus. *Hum. Genet.* 74: 249-255.
- Scheres, J.M. and Hustinx, T.W. 1980. Heritable fragile sites and lymphocyte culture medium containing BrdU. *Am. J. Hum. Genet.* 32: 628-629.
- Schmid, M., Feichtinger, W., Deubelbeiss, C. and Weller, E. 1987a. The fragile site (17)(p12): induction by AT-specific DNA-ligands and population cytogenetics. *Hum. Genet.* 77: 118-121.
- Schmid, M., Feichtinger, W. and Haaf, T. 1987b. The fragile site (16)(q22) II. Sister chromatid exchanges. *Hum. Genet.* 76: 365-368.
- Schmid, M., Feichtinger, W., Jessberger, A., Kohler, J. and Lange, R. 1986. The fragile site (16)(q22) I. Induction by AT-specific DNA-ligands and population frequency. *Hum. Genet.* 74: 67-73.
- Schmid, M., Hungerford, D.A., Poppen, A. and Engel, W. 1984. The use of distamycin A in human lymphocyte cultures. *Hum. Genet.* 65: 377-384.
- Schmid, M., Klett, C. and Niederhofer, A. 1980. Demonstration of a heritable fragile site in human chromosome 16 with distamycin A. *Cytogenet. Cell Genet.* 28: 87-94.
- Schmid, M., Ott, G., Haaf, T. and Scheres, J.M.J.C. 1985. Evolutionary conservation of fragile sites induced by 5-azacytidine and 5-azadeoxycytidine in man, gorilla, and chimpanzee. *Hum. Genet.* 71: 342-350.
- Schmidtke, J. and Epplen, J.T. 1980. Sequence organization of animal nuclear DNA. *Hum. Genet.* 55: 1-18.

- Schneider, N.R., Chaganti, R.S.K. and German, J. 1980. Analysis of a BrdU-sensitive site in the Cactus mouse Peromyscus eremicus: chromosomal breakage and sister chromatid exchange. *Chromosoma* 77: 379-389.
- Schumm, J.W., Knowlton, R.G., Braman, J.C., Barker, D.F., Botstein, D., Akots, G., Brown, V.A., Gravius, T.C., Helms, C., Hsiao, K., Rediker, K., Thurston, J.G. and Donis-Keller, H. 1988. Identification of more than 500 restriction fragment length polymorphisms by screening random genomic clones. *Am. J. Hum. Genet.* 42: 143-159.
- Schwartz, D.C. and Cantor, C.R. 1984. Separation of yeast chromosome-sized DNAs by pulse field gradient gel-electrophoresis. *Cell* 37: 67-75.
- Sealey, P.G., Whittaker, P.A. and Southern, E.M. 1985. Removal of repeated sequences from hybridisation probes. *Nucleic Acids Res.* 13: 1905-1922.
- Sekiguchi, M., Hayakawa, H., Makino, F., Tanaka, K. and Okada, Y. 1976. A human enzyme that liberates uracil from DNA. *Biochem. Biophys. Res. Commun.* 73: 293-299.
- Shabtai, F., Klar, D., Bichacho, S., Hart, J. and Halbrecht, I. 1983. Familial fragility on chromosome 16 (Fra16q22) enhanced by both interferon and distamycin A. *Hum. Genet.* 63: 341-344.
- Shabtai, F., Orlyn, J., Hart, J., Bichacho, S. and Halbrecht, I. 1987. Alpha-interferon and fragility at 16q22. *Hum. Genet.* 75: 48-52.
- Simmers, R.N. 1988. Gene mapping and the study of fragile sites in humans using chromosomal in situ hybridization. Ph.D. dissertation, University of Adelaide.

- Simmers, R.N. and Sutherland, G.R. 1988. Further localization of ETS1 indicates that the chromosomal rearrangement in Ewing sarcoma does not occur at fra(11)(q23). Hum. Genet. (In press).
- Simmers, R.N., Sutherland, G.R., West, A. and Richards, R.I. 1987a. Fragile sites at 16q22 are not at the breakpoint of the chromosomal rearrangement in AMMol. Science 236: 92-94.
- Simmers, R.N., Mulley, J.C., Hyland, V.J., Callen, D.F and Sutherland, G.R. 1987b. Mapping the human α -globin gene complex to 16p13.2- \rightarrow pter. J. Med. Genet. 24: 761-766.
- Simmers, R.N., Stupans, I., Sutherland, G.R. 1986. Localization of the human haptoglobin genes distal to the fragile site at 16q22 using in situ hybridization. Cytogenet. Cell Genet. 41: 38-41.
- Skolnick, M.H. and White, R. 1982. Strategies for detecting and characterizing restriction fragment length polymorphisms (RFLP's). Cytogenet. Cell Genet. 32: 58-67.
- Smeets, D.F.C.M., Scheres, J.M.J.C. and Hustinx, T.W.J. 1986. The most common fragile site in man is 3p14. Hum. Genet. 72: 215-220.
- Smith, G.R., Kunes, S.M., Schultz, D.W., Taylor, A. and Triman, K.L. 1981. Structure of chi hotspots of generalized recombination. Cell 24: 249-436.
- Smithies, O. 1955. Zone electrophoresis in starch gels: group variations in the serum proteins of normal human adults. Biochem. J. 61: 629.
- Sorensen, K., Nielsen, J., Holm, V. and Haahr, J. 1979. Fragile site long arm chromosome 16. Hum. Genet. 48: 131-134.
- Southern, E.M. 1975. Detection of specific sequences among DNA fragments separated by gel electrophoresis. J. Mol. Biol. 98: 503-517.

- St George-Hyslop, P.H., Tanzi, R.E., Polinsky, R.J., Haines, J.L., Nee, L., Watkins, P.C., Myers, R.H., Feldman, R.G., Pollen, D., Drachman, D., Growdon, J., Bruni, A., Foncin, J.-F., Salman, D., Frommelt, P., Amaducci, L., Sorbi, S., Piacentini, S., Stewart, G.D., Hobbs, W.J., Conneally, P.M. and Gusella, J.F. 1987. The genetic defect causing familial Alzheimer's disease maps on chromosome 21. *Science* 235: 885-890.
- Stambrook, P.J., Dush, M.K., Trill, J.J. and Tischfield, J.A. 1984. Cloning of a functional human adenine phosphoribosyltransferase (APRT) gene: identification of a restriction fragment length polymorphism and preliminary analysis of DNAs from APRT-deficient families and cell mutants. *Som. Cell Mol. Genet.* 10: 359-367.
- Stent, G.S. 1971. *Molecular Genetics, An Introductory Narrative.* W.H. Freeman, San Francisco.
- Stoker, N.G., Cheah, K.S.E., Griffin, J.R., Pope, F.M. and Solomon, E. 1985. A highly polymorphic region 3' to the human Type II collagen gene. *Nucleic Acids. Res.* 13: 4613-4622.
- Sutherland, G.R. 1977. Fragile sites on human chromosomes: demonstration of their dependence on the type of tissue culture medium. *Science* 197: 265-266.
- Sutherland, G.R. 1979. Heritable fragile sites on human chromosomes I. Factors affecting expression in lymphocyte culture. *Am. J. Hum. Genet.* 31: 125-135.
- Sutherland, G.R. 1981. Heritable fragile sites on human chromosomes. VII. Children homozygous for the BrdU-Requirement fra(10)(q25) are phenotypically normal. *Am. J. Hum. Genet.* 33: 946-949.
- Sutherland, G.R. 1982. Heritable fragile sites on human chromosomes. IX. Population cytogenetics and segregation analysis of the BrdU requiring fragile site at 10q25. *Am. J. Hum. Genet.* 34: 753-756.

- Sutherland, G.R. 1983. The fragile X chromosome. *Int. Rev. Cyto.* 81: 107-143.
- Sutherland, G.R. 1985. The enigma of the fragile X chromosome. *Trends Genet.* 1: 108-112.
- Sutherland, G.R. 1988. Editorial: Fragile sites and cancer breakpoints- The pessimistic view. *Cancer Genet. Cytogenet.* 31: 5-8.
- Sutherland, G.R. and Baker, E. 1986a. Induction of fragile sites in fibroblasts. *Am. J. Hum. Genet.* 38: 573-575.
- Sutherland, G.R. and Baker, E. 1986b. Effects of nucleotides on expression of the folate sensitive fragile sites. *Am. J. Med. Genet.* 23: 409-417.
- Sutherland, G.R. and Hecht, F. 1985. *Fragile Sites on Human Chromosomes.* New York: Oxford University Press.
- Sutherland, G.R. and Mattei, J.F. 1987. Report of the committee on cytogenetic markers, *Human Gene Mapping 9 (1987)*: Ninth International Workshop on Human Gene Mapping. *Cytogenet. Cell Genet.* 46: 316-324.
- Sutherland, G.R. and Simmers, R.N. 1988. No statistical association between common fragile sites and nonrandom chromosome breakpoints in cancer cells. *Cancer Genet. Cytogenet.* 31: 9-16.
- Sutherland, G.R., Baker, E. and Fratini, A. 1985a. Excess thymidine induces folate sensitive fragile sites. *Am. J. Hum. Genet.* 22: 433-443.
- Sutherland, G.R., Parslow, M.I. and Baker, E. 1985b. New classes of common fragile sites induced by 5-azacytidine and bromodeoxyuridine. *Hum. Genet.* 69: 233-237.
- Sutherland, G.R., Baker, E. and Mulley, J.C. 1982. Genetic length of a human chromosomal segment measured by recombination between two fragile sites. *Science* 217: 373-374.

- Sutherland, G.R., Baker, E. and Seshardi, R.S. 1980. Heritable fragile sites on human chromosomes. V. A new class of fragile site requiring BrdU for expression. *Am. J. Hum. Genet.* 32: 542-548.
- Sutherland, G.R., Jacky, P.B., Baker, E. and Manuel, A. 1983. Heritable fragile sites on human chromosomes. X. New folate-sensitive fragile sites: 6p23, 9p21, 9q32, and 11q23. *Am. J. Hum. Genet.* 35: 432-437.
- Sutherland, G.R., Jacky, P.B., Baker, E.G. 1984. Heritable fragile sites on human chromosomes. XI. Factors affecting expression of fragile sites at 10q25, 16q22, and 17p12. *Am. J. Hum. Genet.* 36: 110-122.
- Sutherland, G.R., Reeders, S., Hyland, V.J., Callen, D.F., Fratini, A. and Mulley, J.C. 1987a. Molecular genetics of human chromosome 16. *J. Med. Genet.* 24: 451-456.
- Sutherland, G.R., Baker, E., Purvis-Smith, S., Hockey, A., Krumins, E. and Eichenbaum, S.Z. 1987b. Prenatal diagnosis of the fragile X using thymidine induction. *Prenat. Diagn.* 7: 197-202.
- Sykes, B.C., Ogilvie, D.J. and Wordsworth, B.P. 1985. Lethal osteogenesis imperfecta and a collagen gene deletion. Length polymorphism provides an alternative explanation. *Hum. Genet.* 70: 35-37.
- Szabo, P., Purrello, M., Rocchi, M., Archidiacono, N., Alhadeff, B., Filippi, G., Toniolo, D., Martini, G., Luzzatto, L. and Siniscalco, M. 1984. Cytological mapping of the human glucose-6-phosphate dehydrogenase gene distal to the fragile-X site suggests a high rate of meiotic recombination across this site. *Proc. Natl. Acad. Sci. USA* 81: 7855-7859.

- Takahashi, E., Hori, T. and Murata, M. 1988. A new rare heritable fragile site at 8q24.1 found in a Japanese population. *Clin. Genet.* 33: 91-94.
- Taylor, A.M.R. and Bunday, S. 1983. Spontaneous expression of the chromosome fragile site fra(10)(q25). *Am. J. Hum. Genet.* 35: 123-125.
- Tedeschi, B., Porfirio, B., Vernole, P., Caporossi, D., Dallapiccola, B. 1987. Common fragile sites: their prevalence in subjects with constitutional and acquired chromosomal instability. *Am. J. Med. Genet.* 27: 471-482.
- Thestrup-Pedersen, K., Esmann, V., Jensen, J.R., Hastrup, J., Thorling, K., Saemundsen, A.K., Bisballe, S., Pallesen, G., Madsen, M., Grazia-Masuccci, M. and Ernberg, I. 1980. Epstein-barr-virus-induced lymphoproliferative disorder converting to fatal burkitt-like lymphoma in a boy with interferon-inducible chromosomal defect. *Lancet* ii: 997-1001.
- Tischfield, J.A. and Ruddle, F.H. 1974. Assignment of the gene for adenine phosphoribosyltransferase to human chromosome 16 by mouse-human somatic cell hybridization. *Proc. Natl. Acad. Sci. USA* 71: 45-49.
- Tommerup, N., Nielsen, K.B. and Mikkelsen, M. 1981. Marker X chromosome induction in fibroblasts by FUDR. *Am. J. Med. Genet.* 9: 263-264.
- Tommerup, N., Sondergaard, F., Tonnesen, T., Kristensen, M., Arveiler, B. and Schinzel, A. 1985. First trimester prenatal diagnosis of a male fetus with fragile X. *lancet* i: 870.
- Tuan, D., Biro, P.B., de Riel, J.K., Lazarus, H. and Forget, B.G. 1979. Restriction endonuclease mapping of the human γ -globin gene loci. *Nucleic Acids Res.* 6: 2519-2544.

- Valerio, D., Dekker, B.M.M., Duyvesteyn, M.G.C., van der Voorn, L., Berkvens, T.M., van Ormondt, H. and van der Eb, A.J. 1986. One adenosine deaminase allele in a patient with severe combined immunodeficiency contains a point mutation abolishing enzyme activity. *EMBO J.* 5: 113-119.
- van den Ouweland, A.M.W., Breuer, M.L., Steenbergh, P.H., Schalken, J.A., Bloemers, H.P.J. and Van de Ven, W.J.M. 1985. Comparative analysis of the human and feline *c-sis* proto-oncogenes. Identification of 5' human *c-sis* coding sequences that are not homologous to the transforming gene of simian sarcoma virus. *Biochim. Biophys. Acta* 825: 140-147.
- Van Dilla, M.A., Deaven, L.L., Albright, K.L., Allen, N.A., Aubuchon, M.R., Bartholdi, M.F., Brown, N.C., Campbell, E.W., Carrano, A.V., Clark, L.M., Cram, L.S., Crawford, B.D., Fuscoe, J.C., Gray, J.W., Hildebrand, C.E., Jackson, P.J., Jett, J.H., Longmire, J.L., Lozes, C.R., Luedemann, M.L., Martin, J.C., McNinch, J.C., Meincke, L.J., Mendelsohn, M.L., Meyne, J., Moyzis, R.K., Munk, A.C., Perlman, J., Peters, D.C., Silva, A.J. and Trask, B.J. 1986. Human chromosome-specific DNA libraries: construction and availability. *Biotechnology* 4: 537-552.
- Vassart, G., Georges, M., Monsieur, R., Brocas, H., Lequarre, A.S. and Christophe, D. 1987. A sequence in M13 phage detects hypervariable minisatellites in human and animal DNA. *Science* 235: 638-684.
- Veenema, H., Carpenter, N.J., Bakker, E., Hofker, M.H., Millingtonward, A. and Pearson, P.L. 1987. The fragile X syndrome in a large family. III. Investigations on linkage of flanking DNA markers with the fragile site Xq27. *J. Med. Genet.* 24: 413-421.
- Vogel, F. and Motulsky, A.G. 1982. *Human Genetics*. Springer-Verlag, Berlin, Heidelberg and New York.

- Wahl, G.M., Stern, M. and Stark, G.R. 1979. Efficient transfer of large DNA fragments from agarose gels to diazabenzoyloxymethyl paper and rapid hybridization by using dextran sulfate. Proc. Natl. Acad. Sci. USA 76: 3683-3687.
- Wainscoat, J.S. and Thein, S.L. 1985. Human DNA polymorphisms: Applications to cancer studies. TIBS 10: 474-476.
- Wainscoat, J.S., Hill, A.V.S., Boyce, A.L., Flint, J., Hernandez, M., Thein, S.L., Old, J.M., Lynch, J.R., Falusi, A.G., Weatherall, D.J. and Clegg, J.B. 1986. Evolutionary relationships of human populations from an analysis of nuclear DNA polymorphisms. Nature 319: 491-493.
- Wainwright, B.J., Scambler, P.J., Schmidtke, J., Watson, E.A., Law, H.Y., Farrall, M., Cooke, H.J., Eiberg, H. and Williamson, R. 1985. Localization of cystic fibrosis locus to human chromosome 7cen-q22. Nature 318: 384-386.
- Wang, J.-C.C., Beardsley, G.P. and Erbe, R.W. 1985a. Antifolate-induced misincorporation of deoxyuridine monophosphate into DNA by cells from patients with the fragile X syndrome. Am. J. Med. Genet. 21: 691-696.
- Wang, J.-C.C. and Erbe, R.W. 1985b. Thymidylate metabolism in fragile X syndrome cells. Som. Cell Mol. Genet. 11: 353-357.
- Waring, M. 1970. Drugs and DNA: uncoiling of the DNA double helix as evidence of intercalation. Hum. Genet. 9: 234-236.
- Warren, S.T. and Davidson, R.L. 1984. Expression of fragile X chromosome in human-rodent somatic cell hybrids. Som. Cell Mol. Genet. 10: 409-413.
- Warren, S.T., Zhang, F., Licameli, G.R. and Peters, J.F. 1987. The fragile X site in somatic cell hybrids: an approach for molecular cloning of fragile sites. Science 237: 420-423.

- Wasmuth, J.J., Carlock, L.R., Smith, B. and Immken, L.L. 1986. A cell hybrid and recombinant DNA library that facilitate identification of polymorphic loci in the vicinity of the Huntington disease gene. *Am. J. Hum. Genet.* 39: 397-403.
- Weiss, P. 1950. Perspectives in the field of morphogenesis. *Quart. Rev. Biol.* 25: 177-198.
- Weller, P., Jeffreys, A.J., Wilson, V. and Blanchetot, A. 1984. Organization of human myoglobin gene. *EMBO J.* 3: 439-446.
- Wenger, S.L., Hennessey, J.C. and Steele, M.W. 1987. Increased sister chromatid exchange frequency at Xq27 site in affected fragile X males. *Am. J. Med. Genet.* 26: 909-914.
- White, R., Leppert, M., Bishop, D.T., Barker, D., Berkowitz, J., Brown, C., Callahan, P., Holm, T. and Jerominski, L. 1985a. Construction of linkage maps with DNA markers for human chromosomes. *Nature* 313: 101-105.
- White, R., Woodward, S., Leppert, M., O'Connell, P., Hoff, M., Herbst, J., Lalouel, J.-M., Dean, M. and Vande Woude, G. 1985b. A closely linked genetic marker for cystic fibrosis. *Nature* 318: 382-384.
- White, R., Leppert, M., O'Connell, P., Nakamura, Y., Julier, C., Woodward, S., Silva, A., Wolff, R., Lathrop, M. and Lalouel, J.-M. 1986. Construction of human genetic linkage maps: 1. Progress and perspectives. *Cold Spring Harbor Symp. Quant. Biol.* 51: 29-38.
- Wiggs, J., Nordenskjold, M., Yandell, D., Rapaport, J., Grondin, V., Janson, M., Werelius, B., Petersen, R., Craft, A., Riedel, K., Liberfarb, R., Walton, D., Wilson, W. and Dryja, T. 1988. Prediction of the risk of hereditary retinoblastoma, using DNA polymorphisms within the retinoblastoma gene. *N. Engl. J. Med.* 318: 151-157.

- Wijsman, E.M. 1984. Optimizing selection of restriction enzymes in the search for DNA variants. *Nucleic Acids Res.* 12: 9209-9266.
- Williams, B.G. and Blattner, F.R. 1979. Construction and characterization of the hybrid bacteriophage lambda charon vectors for DNA cloning. *J. Virol.* 29: 555-575.
- Williams, J.G. 1981. The preparation and screening of a cDNA clone bank. In: *Genetic Engineering I*. Williamson, R., ed. Academic Press, London and New York.
- Wong, Z., Wilson, V., Jeffreys, A.J. and Thein, S.L. 1986. Cloning a selected fragment from a human DNA 'fingerprint': isolation of an extremely polymorphic minisatellite. *Nucleic Acids Res.* 14: 4605-4616.
- Wong, Z., Wilson, V., Patel, I., Povey, S. and Jeffreys, A.J. 1987. Characterization of a panel of highly variable minisatellites cloned from human DNA. *Ann. Hum. Genet.* 51: 269-288.
- Woo, S.L.C., Lidsky, A.S., Guttler, F., Chandra, T. and Robson, K.J.H. 1983. Cloned human phenylalanine hydroxylase gene allows prenatal diagnosis and carrier detection of classical phenylketonuria. *Nature* 306: 151-155.
- Wu, R., ed. 1979. *Recombinant DNA, Methods in Enzymology*. Vol. 68. Academic, New York.
- Wyman, A.R. and White, R. 1980. A highly polymorphic locus in human DNA. *Proc. Natl. Acad. Sci. USA* 77: 6754-6758.
- Yunis, J.J. and Soreng, A.L. 1984. Constitutive fragile sites and cancer. *Science* 226: 1199-1203.
- Zhou, X.T., Reidy, J.R. and Chen, A.T.L. 1982. Chromosome fragility in folic acid-deficient medium. *Am. J. Hum. Genet.* 34: 153A.

Zimmer, C. 1975. Effects of the antibiotics netropsin and distamycin A on the structure and function of nucleic acids. *Progr. Nucleic Acid. Res. Mol. Biol.* 15: 285-318.

Zimmer, C. and Wahnert, U. 1986. Nonintercalating DNA-binding ligands: specificity of the interaction and their use as tools in biophysical, biochemical and biological investigations of the genetic material. *Prog. Biophys. molec. Biol.* 47: 31-112.

APPENDIXES

APPENDIX A

PEDIGREES OF THE UTAH FAMILIES

This appendix contains the pedigrees of the UTAH families 981 (pedigree K-1329), 982 (pedigree K-1331), 983 (pedigree K-1333), 984 (pedigree K-1340), 985 (pedigree K-1341) and 1029 (pedigree K-1345). The individuals in each pedigree (squares, representing males; circles, representing females) are identified by a specific GM number. The order of the individuals in the pedigrees corresponds to the order presented in the tables of Appendix C and D.

FAMILY 981

UTAH PEDIGREE K-1329

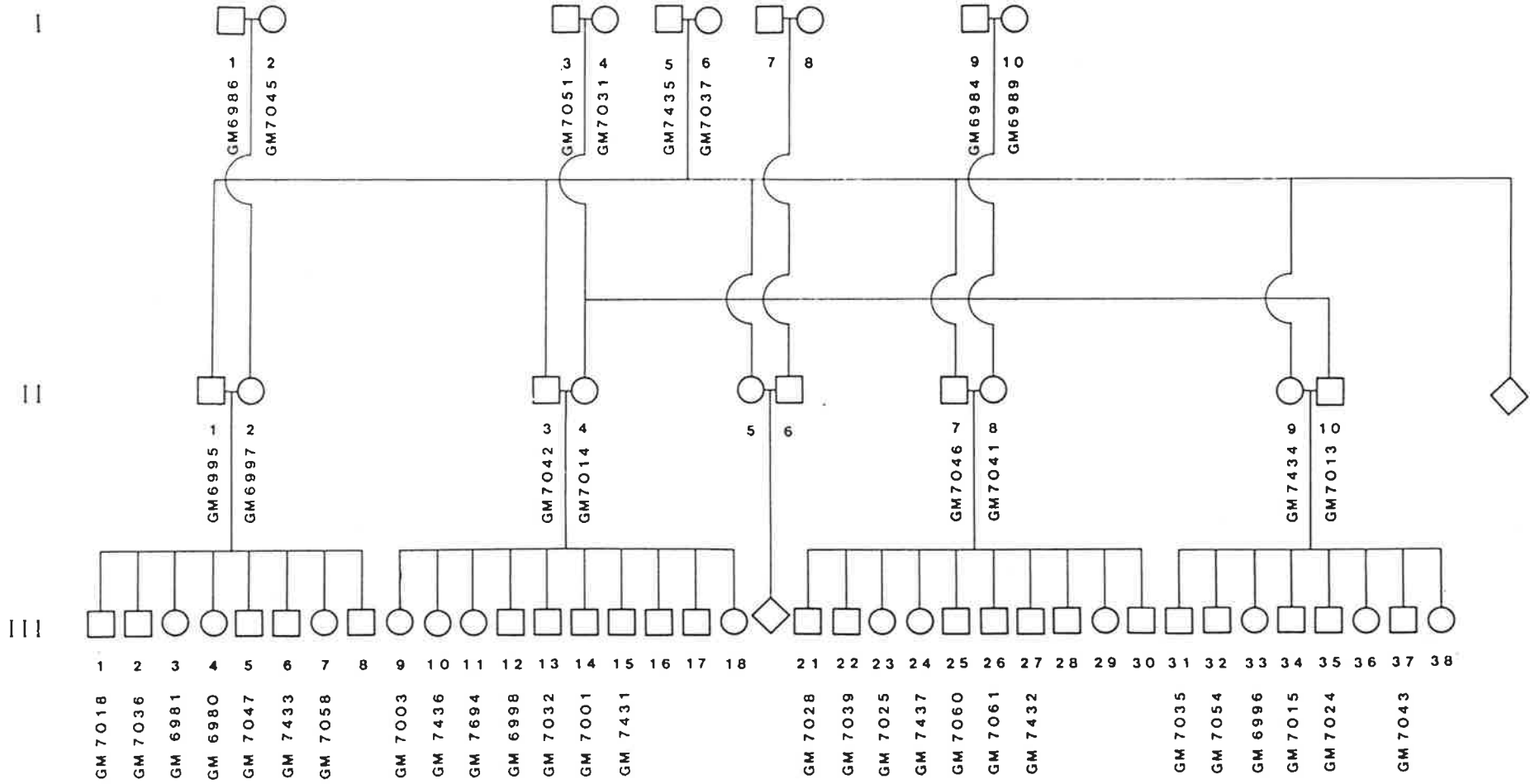

KEY:  SEX UNSPECIFIED

FAMILY 982

UTAH PEDIGREE K-1331

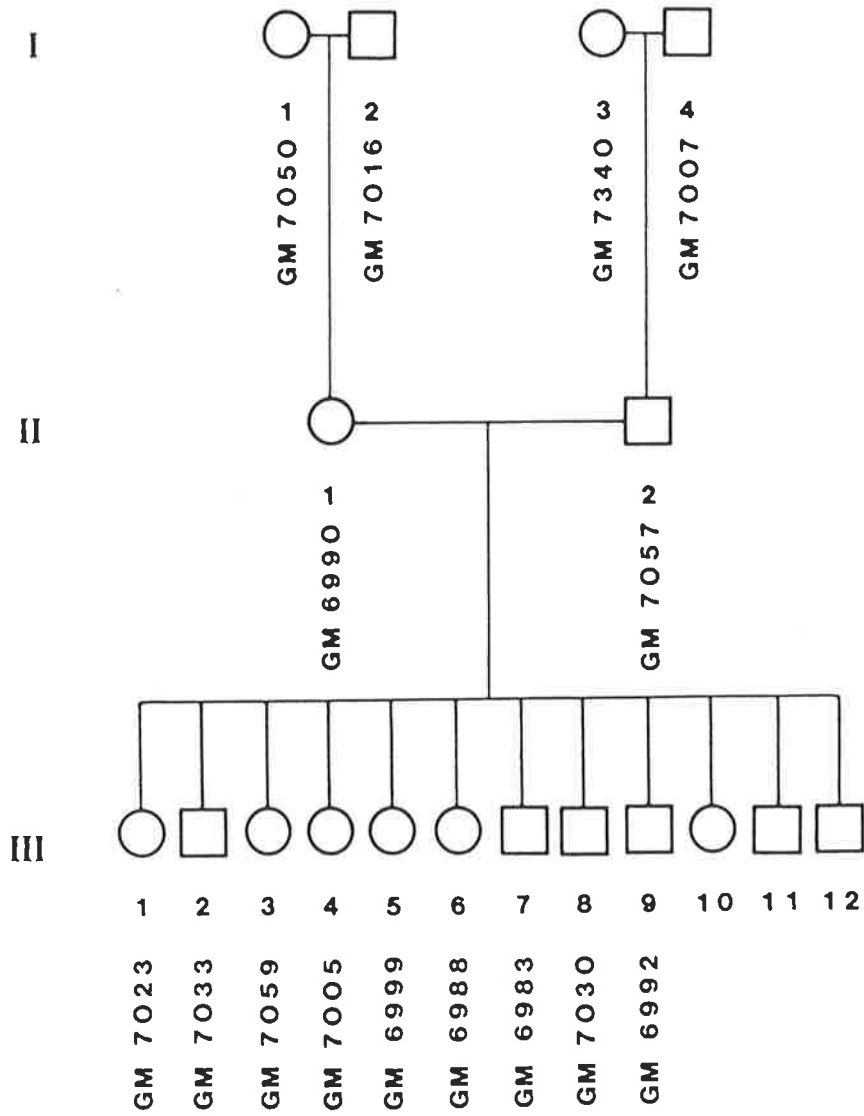

FAMILY 983

UTAH PEDIGREE K-1333

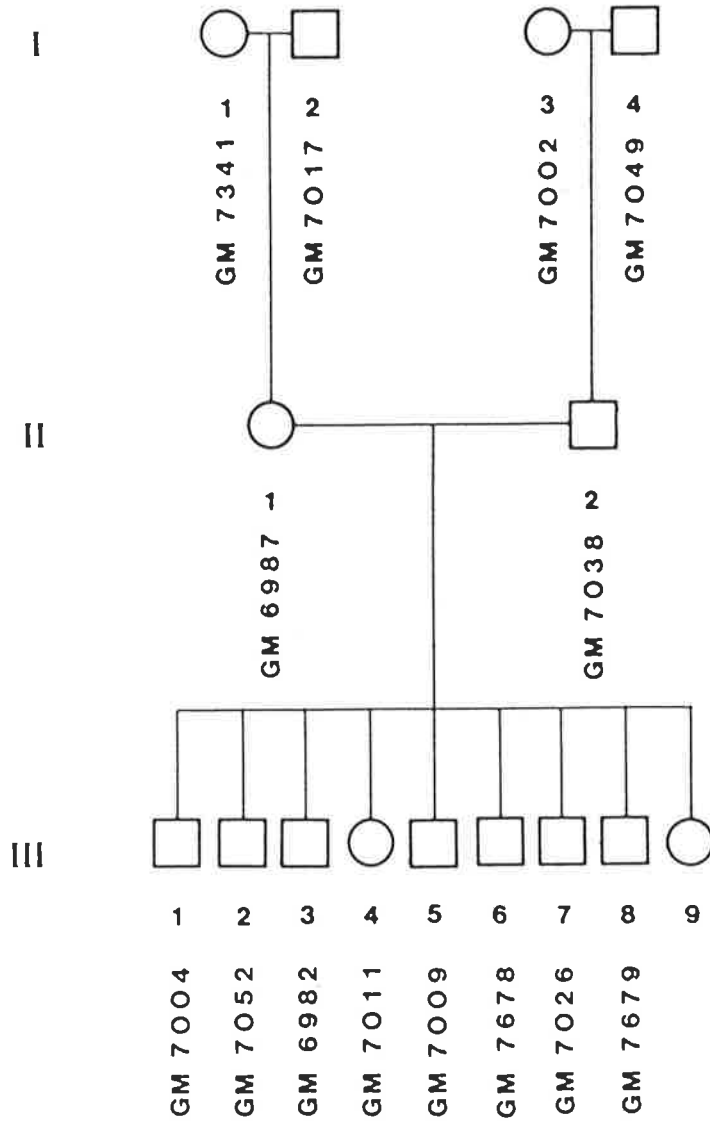

FAMILY 984

UTAH PEDIGREE K-1340

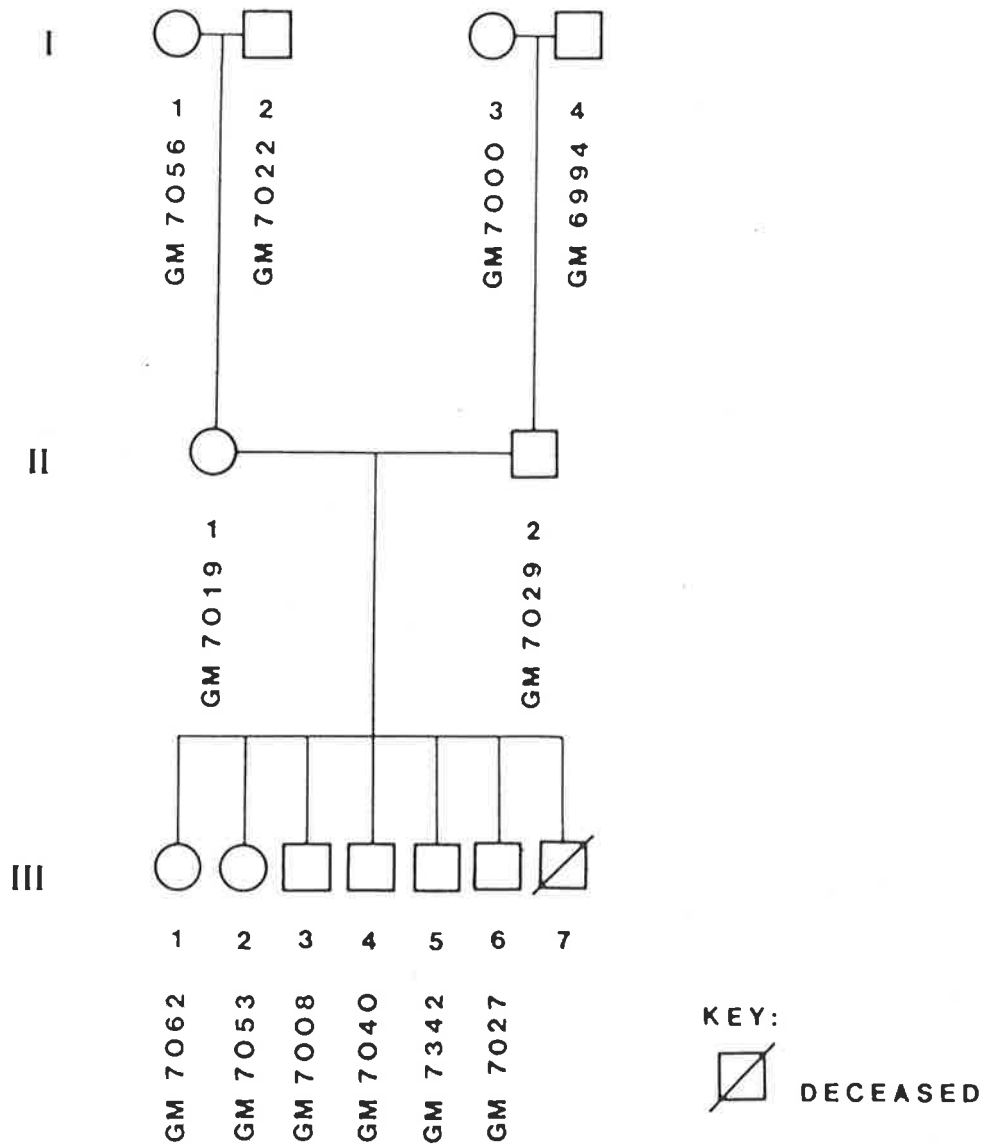

FAMILY 985

UTAH PEDIGREE K-1341

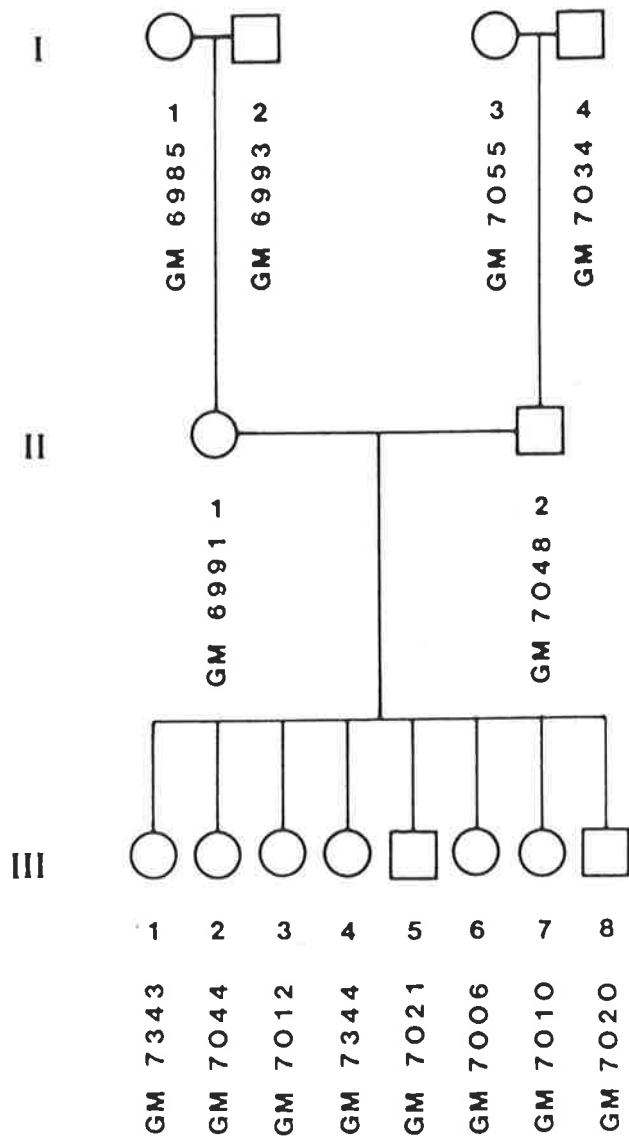

FAMILY 1029

UTAH PEDIGREE K-1345

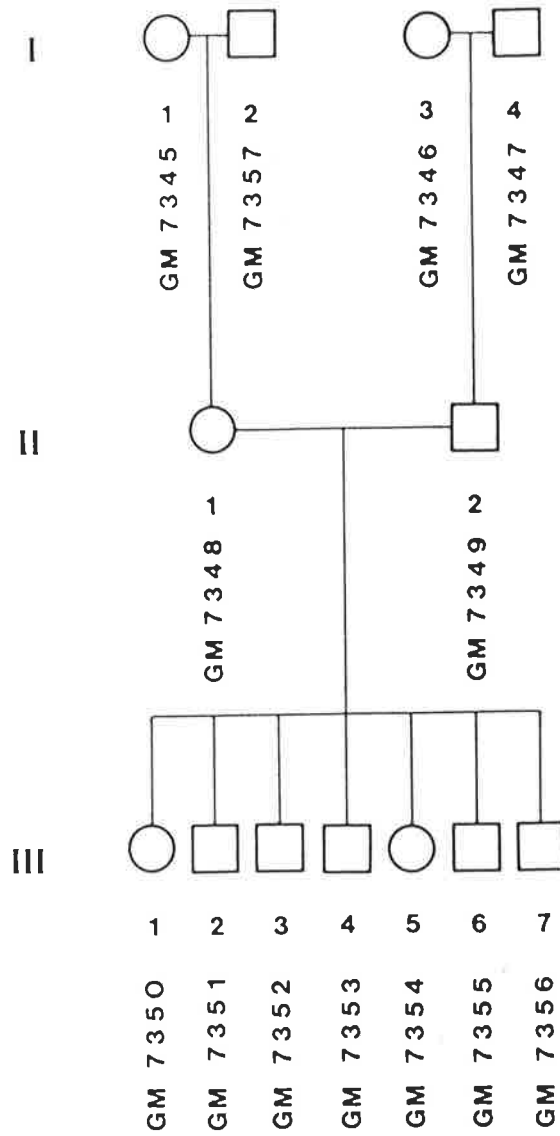

APPENDIX B



PEDIGREES OF THE INFORMATIVE FRAGILE SITE FAMILIES



This appendix contains the pedigrees of the FRA16A family (10556) and the FRA16B families (4139, 12273, 16498, 16967 and 17043).



The order of the individuals in each pedigree (squares, representing males; circles, representing females) corresponds to the order presented in the tables of Appendix E and F.

Key to FRA16A pedigree:

  FRA16A carriers.

  tested, negative for FRA16A.

  not tested (applicable also for FRA16B pedigrees).

  deceased (applicable also for FRA16B pedigrees).

Key to FRA16B pedigrees:

  FRA16B carriers.

 homozygous for FRA16B.

  tested, negative for FRA16B.

10556

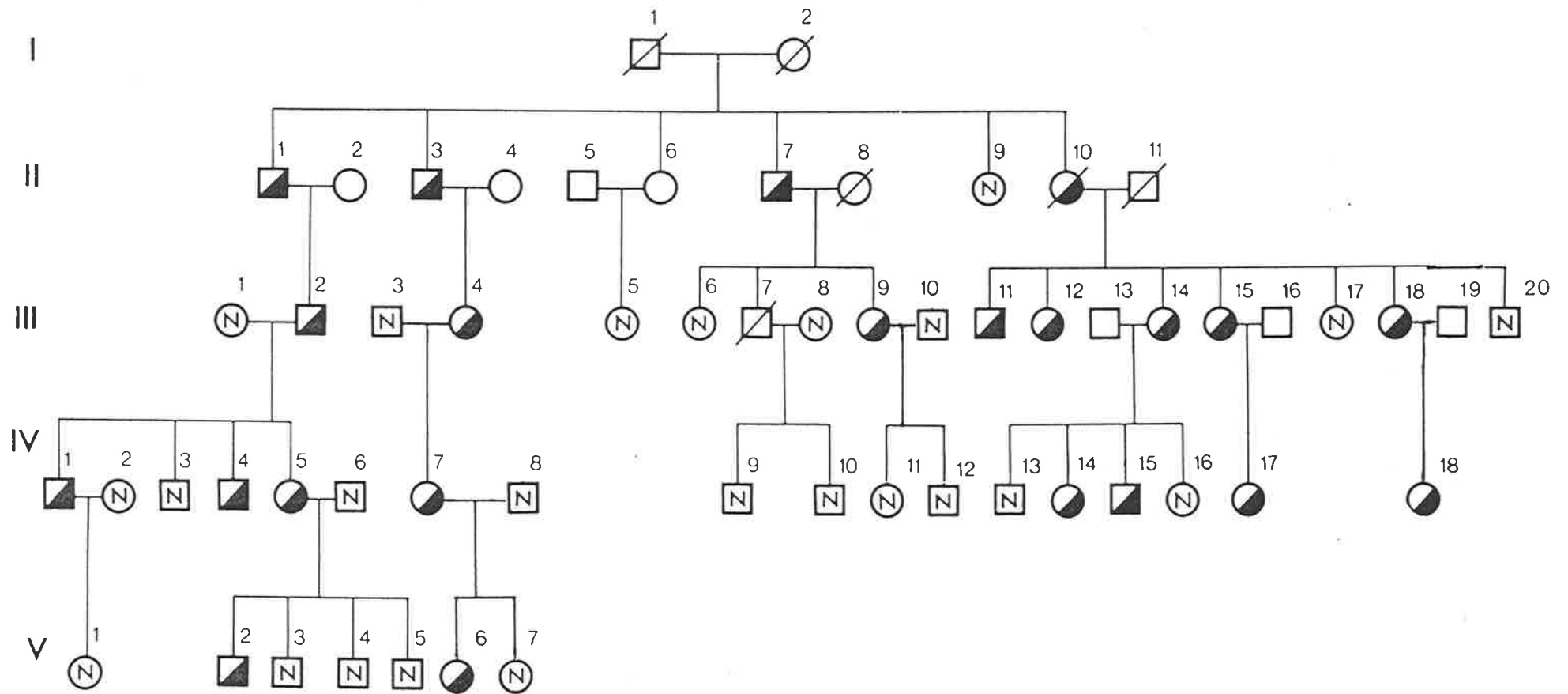

4139

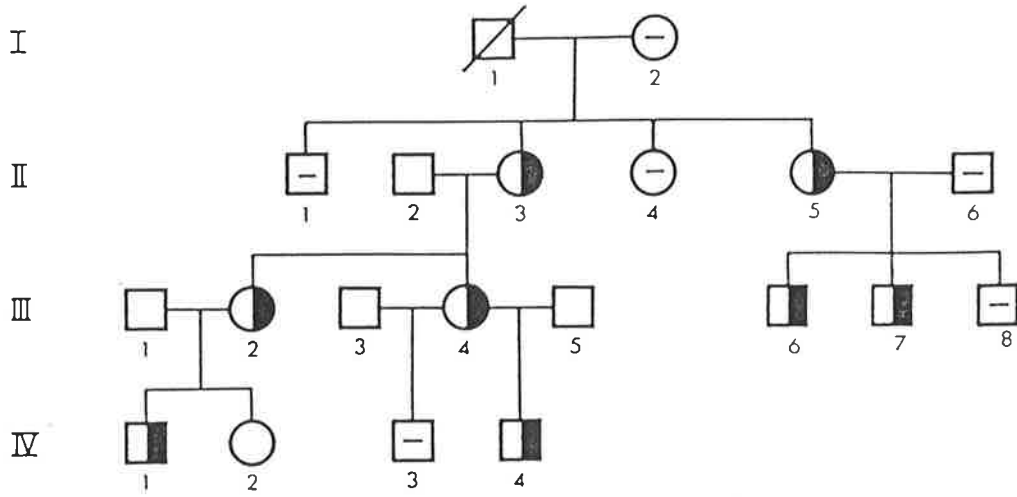

12273

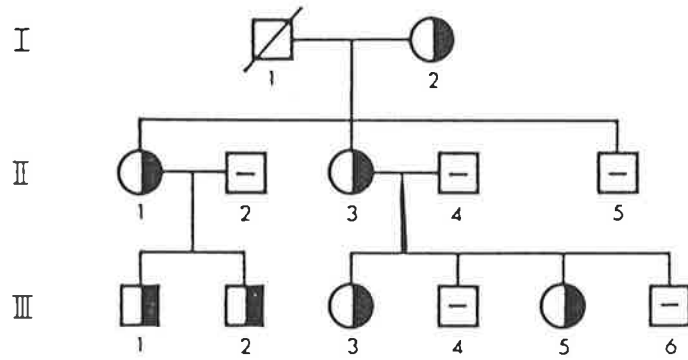

16498

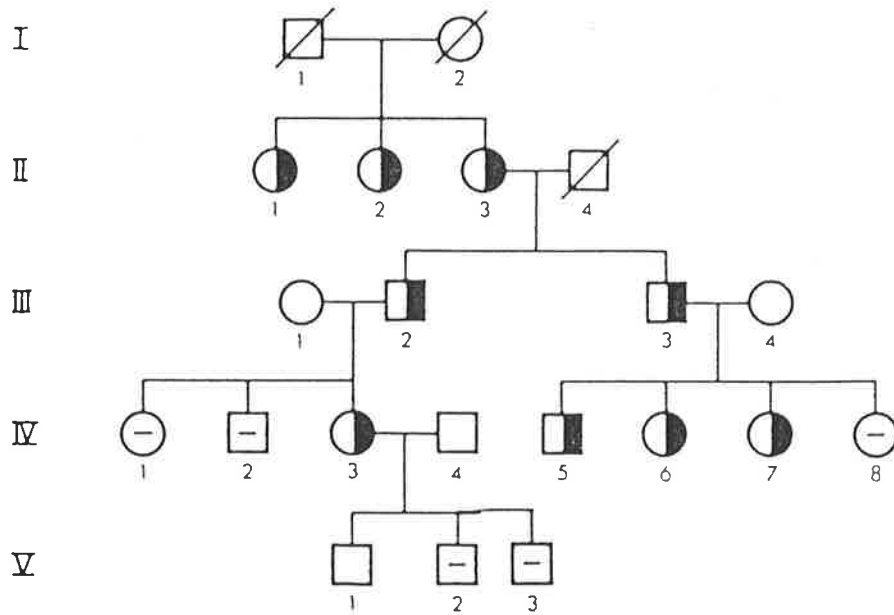

16967

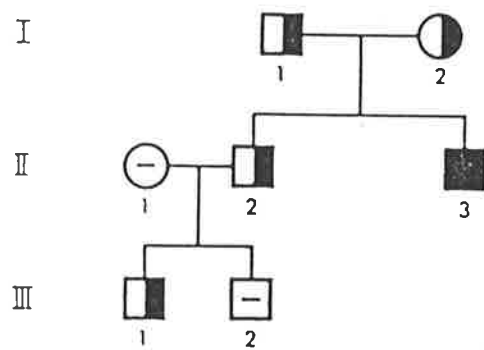

17043

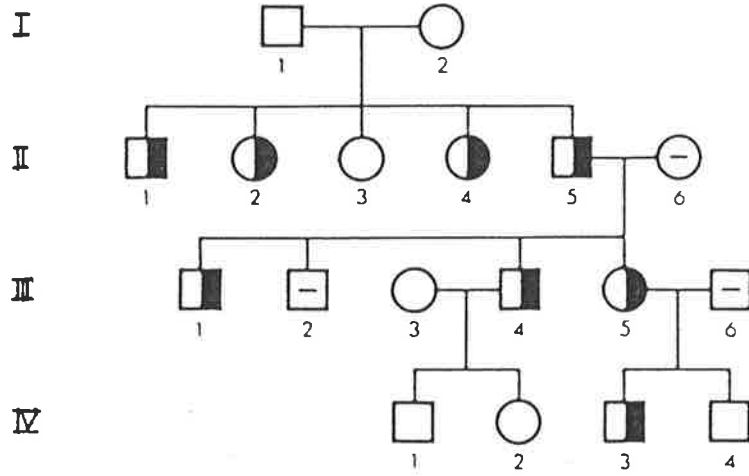

APPENDIX C

TYPING RESULTS IN UTAH FAMILIES 981, 982, 984 AND 985

WITH D16S8 AND D16S79

UTAH 981^a

GENERATION	NO.	GM NO.	<u>D16S8</u>	<u>D16S79</u>
I	1	6986	A1/A2	B/E
	2	7045	A2/A2	E/E
	3	7051	A1/A1	A/B
	4	7031	A2/A2	B/D
	5	7435	A1/A1	B/E
	6	7037	A1/A2	B/D
	7	-	-	-
	8	-	-	-
	9	6984	A1/A2	B/E
	10	6989	A1/A2	B/B
II	1	6995	A1/A2	B/E NR ^b
	2	6997	A1/A2	B/E
	3	7042	A1/A1	D/E NR
	4	7014	A1/A2	B/D
	5	-	-	-
	6	-	-	-
	7	7046	A1/A2	B/E NR
	8	7041	A1/A2	B/B
	9	7434	A1/A2	D/E R
	10	7013	A1/A2	B/B
III	1	7018	A1/A1	B/E
	2	7036	A1/A1	B/B NR, R ^c
	3	6981	A1/A1	B/E
	4	6980	A1/A1	B/E
	5	7047	A1/A1	B/E
	6	7433	A1/A2	B/B
	7	7058	A1/A2	B/B
	8	-	-	-
	9	7003	A1/A1	B/E NR
	10	7436	A1/A1	A/E ^d NR
	11	7694	A1/A1	A/E ^d NR
	12	6998	A1/A1	A/D
	13	7032	-	-
	14	7001	A1/A2	D/D NR
	15	7431	A1/A2	D/D NR
	16	-	-	-
	17	-	-	-
	18	-	-	-

APPENDIX C (Continued)

UTAH 981 (Continued)

GENERATION	NO.	GM NO.	<u>D16S8</u>	<u>D16S79</u>
III	21	7028	-	-
	22	7039	A1/A1	B/E NR
	23	7025	A2/A2	B/B NR
	24	7437	A2/A2	B/B NR
	25	7060	A1/A2	B/E
	26	7061	A2/A2	B/B NR
	27	7432	A2/A2	B/B NR
	28	-	-	-
	29	-	-	-
	30	-	-	-
	31	7035	? ^e	-
	32	7054	?	-
	33	6996	?	-
	34	7015	-	-
	35	7024	?	-
	36	-	-	-
	37	7043	?	-
	38	-	-	-

UTAH 982

GENERATION	NO.	GM NO.	<u>D16S8</u>	<u>D16S79</u>
I	1	7050	A1/A2	B/E
	2	7016	A1/A1	A/E ^d
	3	7340	A2/A2	B/E
	4	7007	A2/A2	B/E
II	1	6990	A1/A2	B/E
	2	7057	A2/A2	B/E
III	1	7023	A1/A2	B/B NR
	2	7033	A1/A2	B/B NR
	3	7059	A2/A2	B/E NR
	4	7005	A1/A2	B/E NR
	5	6999	A2/A2	B/E NR
	6	6988	A1/A2	B/B NR
	7	6983	A1/A2	B/E NR
	8	7030	A1/A2	B/E NR
	9	6992	A1/A2	B/E NR
	10	-	-	-
	11	-	-	-
	12	-	-	-

APPENDIX C (Continued)

UTAH 984

GENERATION	NO.	GM NO.	D16S8	D16S79
I	1	7056	A1/A2	B/E
	2	7022	A2/A2	E/E
	3	7000	A1/A2	B/E
	4	6994	A1/A2	D/E
II	1	7019	A1/A2	B/E
	2	7029	A1/A2	D/E
III	1	7062	A2/A2	E/E NR, NR ^c
	2	7053	A2/A2	E/E NR, NR
	3	7008	A1/A2	D/E
	4	7040	A1/A2	B/E
	5	7342	A2/A2	E/E NR, NR
	6	7027	A1/A2	E/E
	7	-	-	-

UTAH 985

GENERATION	NO.	GM NO.	D16S8	D16S79
I	1	6985	A1/A2	B/D
	2	6993	-	B/E
	3	7055	A1/A2	E/F
	4	7034	A1/A1	E/E
II	1	6991	A2/A2	D/E
	2	7048	A1/A2	E/F
III	1	7343	A1/A2	E/E NR
	2	7044	A1/A2	E/E NR
	3	7012	A2/A2	E/F NR
	4	7344	A2/A2	E/E R
	5	7021	A2/A2	E/F NR
	6	7006	A2/A2	D/F NR
	7	7010	A1/A2	E/E NR
	8	7020	A2/A2	D/F NR

^a See Appendix A for details on pedigrees.

^b Non-Recombinant or Recombinant.

^c NR with respect to loci transmitted from male gamete, but R (or NR) with respect to loci transmitted from female gamete.

^d Could also be B/D genotype.

^e Could not be typed due high lane backgrounds, despite several repeated attempts.

APPENDIX D

TYPING RESULTS IN UTAH FAMILIES 981, 984, 985

AND 1029 WITH D16S4 AND D16S10

UTAH 981^a

GENERATION	NO.	GM NO.	<u>D16S4</u>	<u>D16S10</u>
I	1	6986	A1/A1	A1/A1
	2	7045	A1/A2	A1/A1
	3	7051	A1/A2	A1/A2
	4	7031	A1/A1	A1/A2
	5	7435	A1/A1	A1/A1
	6	7037	A1/A2	A2/A2
	7	-	-	-
	8	-	-	-
	9	6984	A1/A1	A1/A2
	10	6989	A1/A2	A1/A1
II	1	6995	B1/B1	A1/A2
	2	6997	B1/B2	A1/A1
	3	7042	A1/A2	A1/A2
	4	7014	A1/A1	A1/A2
	5	-	-	-
	6	-	-	-
	7	7046	A1/A2	A1/A2
	8	7041	A1/A1	A1/A1
	9	7434	A1/A2	A1/A2
	10	7013	A1/A1	A1/A1
III	1	7018	B1/B1	A1/A1
	2	7036	B1/B1	A1/A2
	3	6981	B1/B1	A1/A1
	4	6980	B1/B1	A1/A2
	5	7047	B1/B2	A1/A1
	6	7433	B1/B1	A1/A1
	7	7058	B1/B1	A1/A2
	8	-	-	-
	9	7003	A1/A1	A1/A1 NR ^b
	10	7436	A1/A2	A1/A2
	11	7694	A1/A2	A1/A2
	12	6998	A1/A2	A2/A2 NR
	13	7032	-	-
	14	7001	A1/A2	A1/A2
	15	7431	A1/A2	A2/A2 NR
	16	-	-	-
	17	-	-	-
	18	-	-	-

APPENDIX D (Continued)

UTAH 981 (Continued)

GENERATION	NO.	GM NO.	<u>D16S4</u>	<u>D16S10</u>
III	21	7028	-	-
	22	7039	A1/A1	A1/A1 NR
	23	7025	A1/A2	A1/A2 NR
	24	7437	A1/A1	A1/A1 NR
	25	7060	A1/A1	A1/A1 NR
	26	7061	A1/A2	A1/A2 NR
	27	7432	A1/A1	A1/A1 NR
	28	-	-	-
	29	-	-	-
	30	-	-	-
	31	7035	A1/A1	A1/A1 NR
	32	7054	A1/A1	A1/A1 NR
	33	6996	A1/A1	A1/A1 NR
	34	7015	A1/A1	A1/A1 NR
	35	7024	A1/A2	A1/A2 NR
	36	-	-	-
	37	7043	A1/A2	A1/A2 NR
	38	-	-	-

UTAH 984

GENERATION	NO.	GM NO.	<u>D16S4</u>	<u>D16S10</u>
I	1	7056	B1/B1	A1/A2
	2	7022	B1/B1	A1/A2
	3	7000	B2/B2	A1/A2
	4	6994	B1/B1	A1/A1
II	1	7019	B1/B1	A1/A2
	2	7029	B1/B2	A1/A2
III	1	7062	B1/B2	A1/A2
	2	7053	B1/B1	A2/A2 NR
	3	7008	B1/B2	A1/A2
	4	7040	B1/B2	A1/A2
	5	7342	B1/B2	A1/A2
	6	7027	B1/B2	A1/A2
	7	-	-	-

APPENDIX D (Continued)

UTAH 985

GENERATION	NO.	GM NO.	D16S4	D16S10 ^c
I	1	6985	B1/B2	A1/A1
	2	6993	B1/B1	A1/A2
	3	7055	B1/B2	A1/A2
	4	7034	B1/B1	A1/A1
II	1	6991	B1/B1	A1/A2
	2	7048	B1/B2	A1/A2
III	1	7343	B1/B1	A1/A1 NR
	2	7044	B1/B1	A1/A1 NR
	3	7012	B1/B1	A1/A2
	4	7344	B1/B1	A1/A1 NR
	5	7021	B1/B2	A2/A2 NR
	6	7006	B1/B2	A1/A2
	7	7010	B1/B2	A2/A2 NR
	8	7020	B1/B2	A2/A2 NR

UTAH 1029

GENERATION	NO.	GM NO.	D16S4	D16S10
I	1	7345	A1/A2	A1/A2
	2	7357	A1/A2	A2/A2
	3	7346	A1/A1	A1/A1
	4	7347	A1/A2	A1/A1
II	1	7348	A1/A2	A1/A2
	2	7349	A1/A1	A1/A1
III	1	7350	A1/A2	A1/A2 NR
	2	7351	A1/A2	A1/A2 NR
	3	7352	A1/A1	A1/A1 NR
	4	7353	A1/A1	A1/A1 NR
	5	7354	A1/A1	A1/A1 NR
	6	7355	A1/A2	A1/A2 NR
	7	7356	A1/A2	A1/A2 NR

^a See Appendix A for details on pedigrees.

^b Non-Recombinant.

^c RsaI genotypes were identical to the TaqI genotypes.

APPENDIX E

TYPING RESULTS FOR FRA16A FAMILY 10556 WITH D16S8 AND D16S79^a

GENERATION	NO.	D16S8	D16S79	FRA16A
I	1	-	-	-
	2	-	-	-
II	1	-	-	+
	2	-	-	-
	3	-	-	+
	4	-	-	-
	5	-	-	-
	6	-	-	-
	7	-	-	+
	8	-	-	-
	9	-	-	-
	10	-	-	+
	11	-	-	-
III	1	A1/A1	B/E	-
	2	A1/A2	B/C	+
	3	A1/A2	B/E	-
	4	A1/A2	C/E	+
	5	A1/A2	B/B	-
	6	A2/A2	B/E	-
	7	-	-	-
	8	A1/A1	B/E	-
	9	A2/A2	B/C	+
	10	A2/A2	B/E	-
	11	A2/A2	C/E	+
	12	-	-	-
	13	-	-	-
	14	A1/A2	C/E	+
	15	-	-	-
	16	-	-	-
	17	A1/A2	E/E	-
	18	-	-	+
	19	-	-	-
	20	A1/A1	E/E	-

APPENDIX E (Continued)

GENERATION	NO.	<u>D16S8</u>	<u>D16S79</u>	<u>FRA16A</u>
IV	1	A1/A2	C/E	+
	2	A1/A2	B/B _b	-
	3	A1/A1	B/C ^b	-
	4	A1/A2	C/E	+
	5	A1/A2	C/E	+
	6	A1/A2	A/B	-
	7	A2/A2	C/E	+
	8	A1/A2	D/E	-
	9	A1/A2	B/E	-
	10	A1/A2	B/E	-
	11	A2/A2	B/B	-
	12	A2/A2	C/E	-
	13	A1/A2	C/E	-
	14	A2/A2	C/E	+
	15	A2/A2	C/E	+
	16	A1/A2	C/E	-
	17	A1/A2	B/C	+
	18	A1/A2	C/E	+
V	1	A1/A2	B/E	-
	2	A1/A2	A/C	+
	3	A1/A2	B/E	-
	4	A1/A2	B/E	-
	5	A1/A1	A/E	-
	6	A1/A2	C/E	+
	7	A1/A2	D/E	-

^a See Appendix B for pedigree details.

^b Individual was a recombinant between D16S79 and FRA16A and a recombinant between D16S8 and D16S79, but was not a recombinant between D16S8 and FRA16A.

APPENDIX F

TYPING RESULTS FOR THE INFORMATIVE FRA16B FAMILIES WITH D16S10

PEDIGREE 4139

GENERATION	NO.	<u>D16S10</u>	<u>FRA16B</u>
I	1	-	-
	2	A1/A2	-
II	1	A1/A1	-
	2	A1/A2	-
	3	A1/A1	+
	4	A1/A2	-
	5	A1/A2	+
	6	A1/A1	-
III	1	-	-
	2	A1/A1	+
	3	-	-
	4	A1/A2	+
	5	A1/A1	-
	6	A1/A1	+
	7	A1/A1	+
	8	A1/A2	-
IV	1	A1/A2	+
	2	-	-
	3	A1/A2	-
	4	A1/A1	+

PEDIGREE 12273

GENERATION	NO.	<u>D16S10</u>	<u>FRA16B</u>
I	1	-	-
	2	A1/A2	+
II	1	A1/A2	+
	2	A1/A2	-
	3	A1/A2	+
	4	A1/A2	-
	5	A1/A2	-
III	1	A1/A2	+
	2	A1/A2	+
	3	A1/A2	+
	4	A1/A2	-
	5	A2/A2	+
	6	A1/A1	-

APPENDIX F (Continued)

PEDIGREE 16498

GENERATION	NO.	D16S10	FRA16B
I	1	-	-
	2	-	-
II	1	A1/A2	+
	2	A1/A2	+
	3	A1/A2	+
	4	-	-
III	1	-	-
	2	A1/A2	+
	3	A1/A2	+
	4	-	-
IV	1	A1/A2	-
	2	A1/A2	-
	3	A1/A2	+
	4	-	-
	5	A1/A2	+
	6	A1/A2	+
	7	A1/A2	+
	8	A1/A1	-
V	1	-	-
	2	-	-
	3	A1/A1	-

PEDIGREE 16967

GENERATION	NO.	D16S10	FRA16B
I	1	A2/A2	+
	2	A1/A1	+
II	1	-	-
	2	A1/A2	+
	3	-	+
III	1	A1/A2	+
	2	A1/A2	-

APPENDIX F (Continued)

PEDIGREE 17043

GENERATION	NO.	<u>D16S10</u>	<u>FRA16B</u>
I	1	-	-
	2	-	-
II	1	A1/A1	+
	2	A1/A1	+
	3	A1/A2	-
	4	A1/A2	+
	5	A1/A1	+
	6	-	-
III	1	-	+
	2	-	-
	3	-	-
	4	-	+
	5	-	+
	6	-	-
IV	1	-	-
	2	-	-
	3	-	+
	4	-	-

APPENDIX G

PAPERS PUBLISHED OR ACCEPTED FOR PUBLICATION

This appendix contains papers that were published or accepted for publication, on work directly resulting from this thesis. Listed below are the roles I played in the work described in these papers.

1. (Chapter 1).

Sutherland, G.R., Baker, E. and Fratini, A. 1985a. Excess thymidine induces folate sensitive fragile sites. *Am. J. Hum. Genet.* 22: 433-443.

I was responsible for contributing a major part in the formulation of the model of the folate sensitive fragile site. I wrote some of the discussion and did most of the literature survey for it.

2. (Chapter 1, 4).

Fratini, A., Simmers, R.N., Callen, D.F., Hyland, V.J., Tischfield, J.A., Stambrook, P.J. and Sutherland, G.R. 1986. A new location for the human adenine phosphoribosyltransferase gene (APRT) distal to the haptoglobin (HP) and fra(16)(q23) (FRA16D) loci. *Cytogenet. Cell Genet.* 43: 10-13.

I carried out the Southern blot experiments and wrote the majority of the paper. Simmers carried out and analyzed the results of the in situ hybridization and wrote those parts of the paper pertaining to this.

3. (Chapter 1).

Sutherland, G.R., Reeders, S., Hyland, V.J., Callen, D.F., Fratini, A. and Mulley, J.C. 1987a. Molecular genetics of human chromosome 16.

J. Med. Genet. 24: 451-456.

I provided data regarding the regionally mapped chromosome 16 λ clones that were isolated from the recombinant CY17 library. In addition the data referring to the remapping of APRT came from publication number 2.

4. (Chapter 1).

Puspurs, A.H., Baker, E., Callen, D.F., Fratini, A. and Sutherland, G.R. 1988. Translocation breakpoint in t(11;14) in B-Cell Leukemia is not at the rare fragile site at 11q13.3. Cancer Genet. Cytogenet. 31: 25-30.

I carried out the hybridization experiment seen in Fig. 1 of the paper and discussed the content of the paper with Dr. Puspurs.

5. (Chapters 1, 4, 6 and 7).

Callen, D.F., Hyland, V.J., Baker, E., Fratini, A., Simmers, R.N., Mulley, J.C. and Sutherland, G.R. 1988a. Fine mapping of gene probes and anonymous DNA fragments to the long arm of chromosome 16. Genomics 2: 144-153.

I provided the λ clones D16S10 and D16S11, that were isolated from the recombinant CY17 library, and which were used for in situ hybridization experiments by E. Baker and Dr. D. Callen.

6. (Chapter 4)

Fratini, A., Baker, E.G., Callen, D.F., Hyland, V.J. and Sutherland, G.R. 1988a. ACHF249 (D22S14) detects a common PstI RFLP and maps at 22cen->22q13.1. Nucleic Acids Res. (accepted for publication)

I carried out all the work and wrote the paper. ACHF249 was used for in situ hybridization, which was carried out by E. Baker and Dr. D.

Callen.

7. (Chapters 5 and 6).

Fratini, A., Baker, E.G., Callen, D.F., Reeders, S.T., Hyland, V.J. and Sutherland, G.R. 1988b. pACHF1.1 (D16S8) detects a common PvuII RFLP and maps at 16p13.3->16p13.11. Nucleic Acids Res. (Accepted for publication).

I carried out all the work and wrote the paper. The clone λ 247 (D16S8) was used for in situ hybridization, which was carried out by E. Baker and Dr. D. Callen. Dr. S. Reeders kindly provided pACHF1 which was used for the subcloning experiments that were done by me.

8. (Chapter 5 and 6).

Fratini, A., Baker, E.G., Callen, D.F., Hyland, V.J. and Sutherland, G.R. 1988c. RsaI and TaqI RFLPs for pACHF3.5 (D16S10). Nucleic Acids Res. (Accepted for publication).

I carried out all the work and wrote the paper. pACHF3.5 was used for in situ hybridization, which was carried out by E. Baker and Dr. D. Callen.

Sutherland, G. R., Baker, E. & Fratini, A. (1985). Excess thymidine induces folate sensitive fragile sites. *American Journal of Medical Genetics*, 22(2), 433-443.

NOTE:

This publication is included in the print copy
of the thesis held in the University of Adelaide Library.

It is also available online to authorised users at:

<http://dx.doi.org/10.1002/ajmg.1320220234>

Fratini A., Simmers R. N., Callen D. F., Hyland V. J., Tischfield J. A., Stambrook P. J. & Sutherland G. R. (1986). A new location for the human adenine hosphoribosyltransferase gene (APRT) distal to the haptoglobin (HP) and fra(16)(q23) (FRA16D) loci. *Cytogenetics and Cell Genetics*, 43(1-2), 10–13.

NOTE:

This publication is included in the print copy
of the thesis held in the University of Adelaide Library.

It is also available online to authorised users at:

<http://dx.doi.org/10.1159/000132291>

Sutherland, G. R., Reeders, S., Hyland, V. J., Callen, D. F., Fratini, A. & Mulley, J. C. (1987). Molecular genetics of human chromosome 16. *Journal of Medical Genetics*, 24(8), 451-456.

NOTE:

This publication is included in the print copy of the thesis held in the University of Adelaide Library.

It is also available online to authorised users at:

<http://dx.doi.org/10.1136/jmg.24.8.451>

Translocation Breakpoint in t(11;14) in B-Cell Leukemia is Not at the Rare Fragile Site at 11q13.3

Arnis H. Puspurs, Elizabeth Baker, David F. Callen,
Antonio Fratini, and Grant R. Sutherland

ABSTRACT The cloned breakpoint at 11q13.3 of the t(11;14)(q13.3;q32.3) in a B-cell lymphocytic leukemia (B-CLL) was used to analyze DNA from individuals with and without the rare folate-sensitive fragile site at 11q13.3. On Southern blots there were no discernible differences. Subclones of the ends of the leukemia breakpoint clone were prepared and used for in situ hybridization to chromosomes expressing fra(11)(q13.3). Both subclones hybridized distal to the fragile site. These experiments indicate that the breakpoints at 11q13.3 in B-CLL (and in a B-cell lymphoma) are not at the fragile site at 11q13.3.

INTRODUCTION

Numerous attempts have been made to link the nonrandom chromosome breakpoints seen in cancer cells with fragile sites on human chromosomes [1-4]. These have mainly rested on circumstantial evidence; but when the breakpoints were mapped in relation to the fragile sites the two features were found not to coincide [5,6].

Yunis [7] reported a patient with t(11;14)(q13.3;q32.3) in small lymphocytic cell lymphoma cells and who also had the rare fragile site at 11q13.3. The breakpoint of the t(11;14)(q13.3;q32) in a patient with B-cell chronic lymphocytic leukemia (B-CLL) has been cloned [8]. The breakpoints at 11q13 in two cases of B-CLL were shown to be within 8 bp of each other and 0.9 kb from the breakpoint in a B-cell lymphoma, also with the t(11;14) [8]. This cloned breakpoint has been used to show that these cancer cell breakpoints at 11q13.3 do not coincide with the rare fragile site at 11q13.3. This was achieved using Southern blot analysis of DNA from individuals with the fragile site and by in situ hybridization, which showed that the clone does not span the fragile site.

From the Cytogenetics Unit, Adelaide Children's Hospital, North Adelaide, Australia.

Address reprint requests to Dr. Grant R. Sutherland, Cytogenetics Unit, Adelaide Children's Hospital, North Adelaide, S.A. 5006, Australia.

Received July 3, 1987; accepted September 4, 1987.

MATERIALS AND METHODS

Construction of Subclones

The clone λ 1386-4 was received from Dr. Y. Tsujimoto. This clone has an insert of approximately 16 kb of chromosome #11 spanning the breakpoint in the t(11;14) of B-CLL [8]. The insert from λ 1386-4 was removed from the λ phage vector EMBL3A by *SalI* digestion. Subclones of the ends of this insert were derived by further restriction enzyme digestion and isolation of repeat free fragments (determined by using total human DNA as a probe). The λ 1386-4 insert had *SalI* ends that were preserved in the subcloning procedure, thus, ensuring that it was the ends that were subcloned.

The right end was a *SalI/HindIII* fragment that had been cloned into pBR322, to yield the ~2 kb insert pACHA1. This 2-kb insert contains the breakpoint of the lymphoma LN87 but not the breakpoints of the two B-CLL 271 and 1386 [8].

A left *SalI/PvuII* fragment was cloned into pBR322 to yield the ~640 bp insert pACHA2, this insert is more than 10 kb from any of the breakpoints because it originates from the left end of λ 1386-4.

Southern Blot Analysis

Genomic DNA (5 μ g) isolated from blood was cleaved with restriction enzymes, separated by agarose gel electrophoresis, and blotted to GeneScreen Plus (New England Nuclear). The λ 1386-4 probe was labeled with [³²P]dCTP using a nick-translation kit (BRESA) to a specific activity of $\sim 1 \times 10^8$ cpm/ μ g. The probe was pre-associated with sonicated total human DNA to a value of C_0t 200, according to the method of Sealey et al. [9]. The probe was then added at a concentration of 10 ng/ml to the filter and hybridized according to Wahl et al. [10]. After hybridization, the filter was given a final wash at 65°C for 1 hour in 0.1 \times SSPE (1 \times SSPE: 180 mM NaCl, 10mM NaH₂PO₄, and 1 mM EDTA, pH 7.4), 0.1% sodium dodecyl sulfate. The washed filter was exposed to Kodak X-OMAT x-ray film at -70°C for 2 days; an intensifying screen was used.

In Situ Hybridization

Chromosomes expressing the rare fragile site at 11q13, were prepared by culturing and harvesting lymphocytes [11].

The probes, pACHA1 and pACHA2, were labeled to a specific activity of $\sim 3 \times 10^7$ cpm/ μ g, with three tritiated nucleotides and hybridized *in situ* to chromosomes expressing fra(11)(q13) [12], with denaturation of the chromosomes in 70% deionized formamide, 2 \times SSC, pH 7.0 at 70°C for 2 minutes and hybridization of 0.4 μ g/ml probe at 37°C. The slides were dipped in Kodak NTB-2 nuclear research emulsion diluted 2:1 with water, exposed for 15 days, developed and stained.

RESULT

Southern Blot Hybridization

Using λ 1386-4 as a probe, the *BclI*, *HindIII*, and *SstI* restriction enzyme digests of DNA from one chromosomally normal individual and two fra(11)(q13) carriers revealed no apparent difference in the banding pattern (Fig. 1). The repeat free subclones pACHA1 and pACHA2 were similarly used as probes and, again, no detectable difference was observed (results not shown).

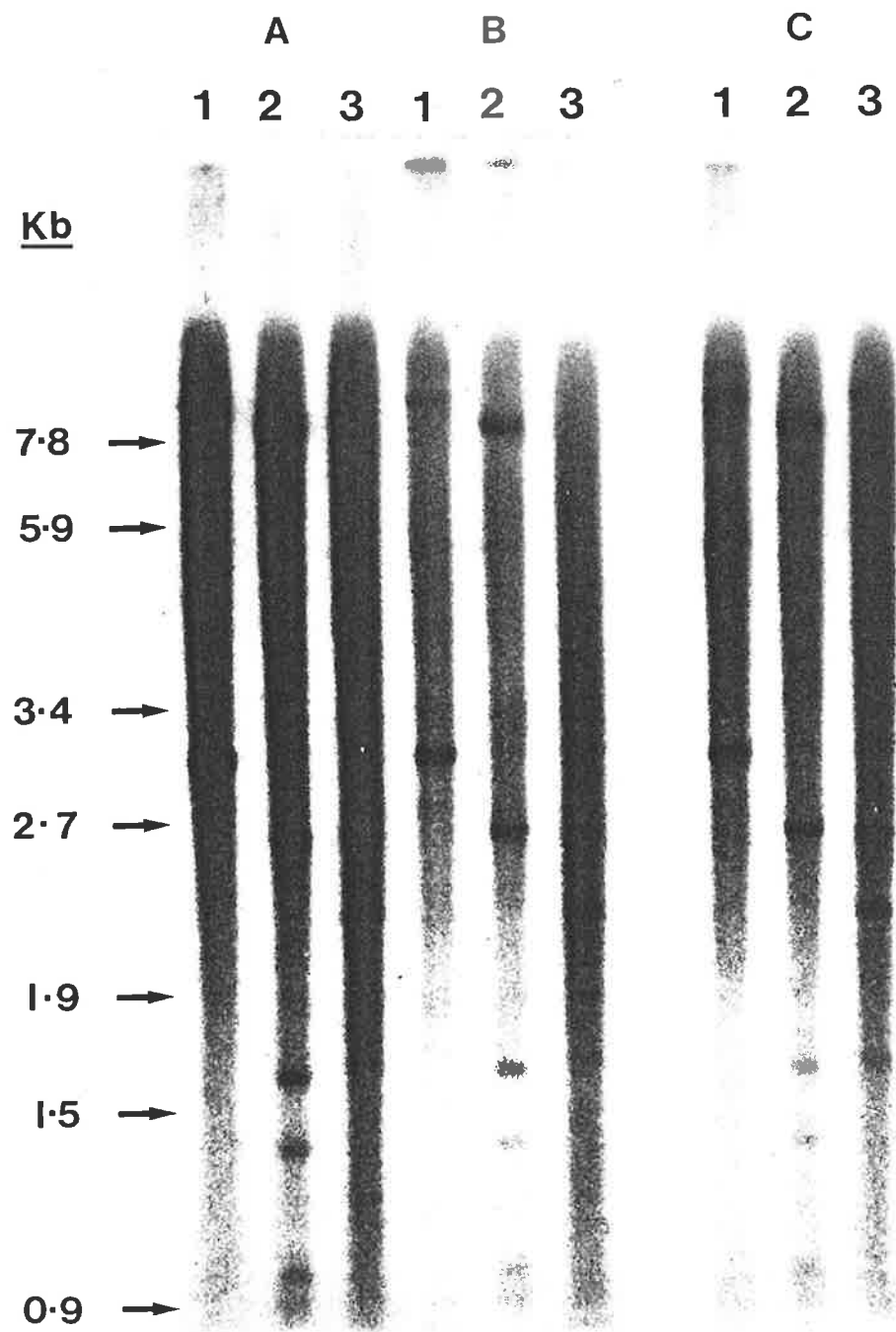

Figure 1 Southern blot hybridization of the preassociated λ 1386-4 chromosome #11-derived probe to DNA from an individual with normal chromosomes (A) and two individuals with the fragile site at 11q13 (B and C), digested with *Bam*HI (1), *Hind*III (2), and *Sst*I (3).

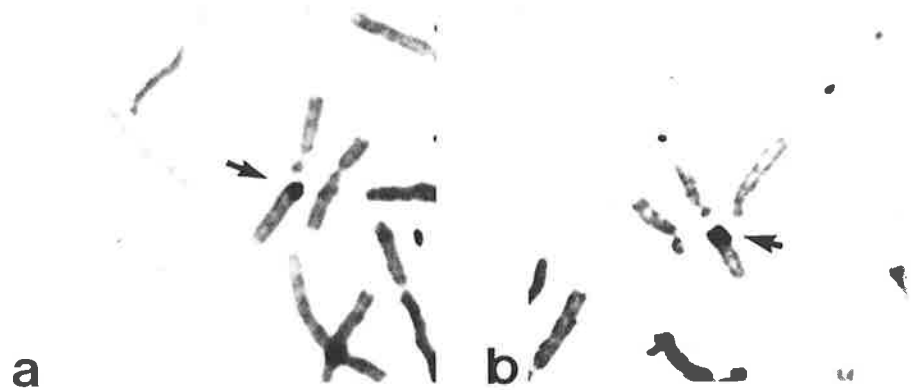

Figure 2 Partial metaphases expressing the fragile site at 11q13.3 after in situ hybridization with (a) pACHA1 and (b) ACHA2 showing signal (arrow) distal to the fragile site.

At the molecular level, λ 1386-4, which spans the chromosomal breakpoint, and its subcloned ends, did not detect any difference between DNA from normal and fra(11)(q13) individuals.

In Situ Hybridization

When the probe pACHA1 was hybridized to normal male metaphases, 15.5% of grains were situated over the long arm of chromosome #11. For pACHA2 7.2% of grains were over this chromosome region. These signals are highly significant because the long arm of chromosome #11 comprises 2.6% of the total haploid chromosome length [13].

The fra(11)(q13) was expressed in 23% of metaphases. Chromosomes expressing

Figure 3 In situ hybridization of the probes pACHA1 and pACHA2 to fra(11)(q13). The distribution of grains is given in the proximal region 11p13 to q13.3 (P), the central region (C), and in the distal region 11q13.3 to q22 (D). The left end (L.E.) refers to hybridizations with pACHA2 and the right end (R.E.) to pACHA1. For hybridizations with pACHA1, 62 grains were scored over 35 chromosomes expressing fra(11)(q13), for pACHA2, 50 grains were scored over 34 chromosomes expressing this fragile site.

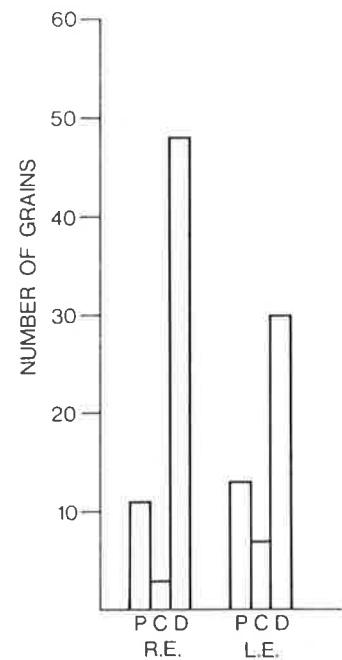

the fragile site were scored for number of grains in the region p13 to the fragile site at q13.3 and from the fragile site to q22 (Fig. 2). The distribution of grains in these two regions and central to the fragile site are given in Figure 3. For both pACHA1 and pACHA2 there was a highly significant excess of grains distal to the fragile site; therefore, both these probes were located distal to fra(11)(q13.3).

DISCUSSION

If the difference in DNA between a normal and a fragile site individual involved an amplification of DNA [14,15] and if the fragile site were at the breakpoint, the Southern analyses carried out should have detected this difference. Because the DNA change present at a fragile site is unknown, this negative result, in itself, is not evidence that the two phenomena do not coincide. However, both ends of the clone λ 1386-4, which span the t(11;14) breakpoint on chromosome #11 map distal to the fragile site at 11q13, thus, the breakpoint and the fragile site cannot coincide.

There have now been two examples of an association between a fragile site and nonrandom breakpoint in malignant cells examined at the molecular level. The breakpoint at 16q22 in the rearrangements involving chromosome #16 in AMMoL does not coincide with either of the fragile sites at 16q22; the rare distamycin A inducible one (*FRA16B*) and the common one (*FRA16D*) [5]. The breakpoint at 11q23 in Ewing's sarcoma (and probably in Askin's tumor and neuroepithelioma) does not coincide with the rare folate-sensitive fragile site at 11q23.3 [6]. Furthermore, it has now been shown by in situ hybridization that the fragile site at 11q13, which had been reported in a patient with a t(11;14) in a small lymphocytic cell lymphoma [7], does not coincide with the breakpoint in this translocation in B-CLL or B-cell lymphoma.

Suggestions that fragile sites and cancer breakpoints may be phenomenologically related have come from statistical studies that suggested they are associated with each other in the genome, and from series of anecdotal case reports. The statistical association no longer appears to be valid, at least for the common fragile sites [16]. The anecdotal case reports probably are the result of ascertainment bias [17]. In no instance has a fragile site and a cancer breakpoint been shown to coincide. Three situations in which such a coincidence were possible have been studied in detail and such a coincidence has not been established in any of them.

The results of these molecular studies indicate that fragile sites and cancer breakpoints are not coincident. If fragile sites have any role in human pathology (and there is none established except for the fragile X) it is probably not in oncogenesis. Nevertheless, fragile sites remain an enigmatic phenomenon worthy of further study.

Supported by the Adelaide Children's Hospital Research Foundation and the National Health and Medical Research Council of Australia.

The authors thank Dr. Y. Tsujimoto for providing the clone 1386-4, and Jenny Hall for her technical assistance.

REFERENCES

1. Hecht F, Sutherland GR (1984): Fragile sites and cancer breakpoints. *Cancer Genet Cytogenet* 12:179-181
2. Yunis JJ (1983): The chromosomal basis of human neoplasia. *Science* 221:227-236.
3. Yunis JJ, Soreng AL (1984): Constitutive fragile sites and cancer. *Science* 226:1199-1204.
4. Shabtai F, Klar D, Hart J, Halbrecht I (1985): On the meaning of fragile sites in cancer risk and development. *Cancer Genet Cytogenet* 18:81-85.

5. Simmers RN, Sutherland GR, West A, Richards RI (1987): Fragile sites at 16q22 are not at the breakpoint of the chromosomal rearrangement in AMMoL Science 236:92-94.
6. Simmers RN, Sutherland GR (1988): Further localization of *ETS1* indicates that the chromosomal rearrangement in Ewing sarcoma does not occur at fra(11)(q23). Hum Genet (in press)
7. Yunis JJ (1984): Fragile sites and predisposition to leukemia and lymphoma. Cancer Genet Cytogenet 12:85-88.
8. Tsujimoto Y, Jaffe E, Cossman J, Gorham J, Norwell PC, Croce CM (1985): Clustering of breakpoints on chromosome 11 in human B-cell neoplasms with the t(11;14) chromosome translocation. Nature 315:340-343.
9. Sealey PG, Whittaker A, Southern EM (1985): Removal of repeated sequences from hybridization probes. Nucl Acid Res 13:1905-1922.
10. Wahl GM, Stern M, Stark GR (1979): Efficient transfer of large DNA fragments from agarose gels to diazobenzyloxymethyl paper and rapid hybridization by using dextran sulfate. Proc Natl Acad Sci USA 76:3683-3687.
11. Sutherland GR (1979): Heritable fragile sites on human chromosomes. I. Factors affecting expression in lymphocyte culture. Am J Hum Genet 31:125-135.
12. Simmers RN, Stupans I, Sutherland GR (1986): Localization of the human haptoglobin genes distal to the fragile site at 16q22 using *in situ* hybridization. Cytogenet Cell Genet 41:38-41.
13. ISCN (1985): **An International System for Human Cytogenetic Nomenclature**, Harnden DG, Klinger HP (eds); published in collaboration with Cytogenet Cell Genet (Karger, Basel, 1985); also in **Birth Defects: Original Article Series, Vol. 21; No. 1** (March of Dimes Birth Defects Foundation, New York, 1985).
14. Sutherland GR, Baker E, Fratini A (1985): Excess thymidine induces folate sensitive fragile sites. Am J Med Genet 22:433-443.
15. Nussbaum RL, Ledbetter DH (1986): Fragile X syndrome: A unique mutation in man. Ann Rev Genet 20:109-145.
16. Sutherland GR, Simmers RN (1988): No statistical association between common fragile sites and nonrandom chromosome breakpoints in cancer cells. Cancer Genet Cytogenet 31:9-16.
17. Sutherland GR (1988): Editorial: Fragile sites and cancer breakpoints—The pessimistic view. Cancer Genet Cytogenet 31:5-8.

Fine Mapping of Gene Probes and Anonymous DNA Fragments to the Long Arm of Chromosome 16

D. F. CALLEN,¹ V. J. HYLAND, E. G. BAKER, A. FRATINI, R. N. SIMMERS, J. C. MULLEY, AND G. R. SUTHERLAND

Cytogenetics Unit, Department of Histopathology, The Adelaide Children's Hospital, King William Road, North Adelaide 5006, South Australia, Australia

Received November 20, 1987; revised January 11, 1988

The fragile site, *FRA16B*, at 16q22.100 and four different translocations with breakpoints at 16q22.102, 16q22.105, 16q22.108, and 16q22.3 were used to locate and order DNA probes. This was achieved by Southern analysis of a somatic cell hybrid panel containing portions of chromosome 16 and by *in situ* hybridization. The anonymous DNA fragments *D16S6*, *D16S10*, and *D16S11* were proximal to *FRA16B* and located at 16q13 → q22.100. *D16S4* and *LCAT* were located at 16q22.100 → q22.102. *TAT* and *HP* were located at 16q22.105 → q22.108. *CTRB* was located distal to 16q22.105 and therefore is in the distal half of 16q22. The order of markers in this region was determined as centromere-*D16S6*, *D16S11*, *D16S10*, *MT-FRA16B-D16S4*, *LCAT-HP*, *TAT*, *CTRB-APRT*-telomere. Linkage studies to determine map distances between the closest markers flanking the fragile site are now in progress. © 1988 Academic Press, Inc.

INTRODUCTION

Chromosome 16 possesses two rare fragile sites, the folate-sensitive *FRA16A* at 16p12.3 and the distamycin A-inducible *FRA16B* at 16q22.1 (Berger *et al.*, 1985). In addition, there are at least two common fragile sites, one at 16q23.1 (*FRA16D*) and one at 16q22 (*FRA16C*) (Berger *et al.*, 1985). The *FRA16B* site has been assigned to, or just distal to, the interface of bands 16q21 and 16q22.1 at 16q22.100 (Magenis and Chamberlin, 1979).

In situ hybridization is a technique for direct regional localization of cloned DNA sequences. Resolu-

tion is usually limited to approximately the width of 1 or 2 chromosome bands due to the scatter of nuclear emissions from the site of hybridization of the radioactively labeled probe. However, this resolution can be dramatically increased by use of defined breaks in the continuity of the chromosome. These breaks may be at fragile sites or at translocation breakpoints. This procedure can allow ordering of closely linked genes and subband assignments of loci.

The anonymous DNA fragments *D16S4*, *D16S6*, *D16S10*, and *D16S11* were initially localized to the region 16q13→q22 by probing Southern blots of mouse/human hybrids (Sutherland *et al.*, 1987; Hyland *et al.*, 1988a). The haptoglobin gene *HP* has been mapped distal to *FRA16B* (Simmers *et al.*, 1986) with a recombination frequency of 9% (Magenis *et al.*, 1970). This gene and the one for tyrosine aminotransferase, *TAT*, have been further localized to 16q22.1 → q22.3 by loss of these two genes in a patient with a deletion of this region (Natt *et al.*, 1986). The gene for chymotrypsinogen B, *CTRB*, has been localized to 16q11 → q22 (Nicholls and Reeders, 1988) and the gene for lecithin:cholesterol acyltransferase, *LCAT*, to 16q22 (Azoulay *et al.*, 1987).

In this study localizations of *D16S4*, *D16S6*, *D16S10*, *D16S11*, and *LCAT* were refined further by *in situ* hybridization to *FRA16B*. Three translocations with breakpoints in 16q22 are reported, and these breakpoints are ordered in relation to one another and to the breakpoint of the line GM1396 which has been used previously to construct a mouse/human hybrid cell line (Callen, 1986). The locations of *D16S4*, *LCAT*, *HP*, *TAT*, and *CTRB* were refined by Southern analysis to genomic blots derived from various mouse/human hybrids containing portions of chromosome 16. In addition, *in situ* hybridizations of

¹ To whom reprint requests should be addressed.

TABLE 1
Panel of Mouse/Hybrid Cell Lines Containing
Portions of Chromosome 16

Cell line	Portion of chromosome 16 present
CY18	Intact 16
CY16	Intact 16
CY3	pter → q24
CY13	p13.11 → qter
CY7	q13 → qter
CY6	q22.102 → qter
CY5	q22.105 → qter
CY2	q24 → qter

D16S4, *HP*, and *TAT* to metaphase chromosomes derived from the translocations with breakpoints in 16q22 allowed confirmation of ordering of these breakpoints and in some cases further refinement of gene localizations.

MATERIALS AND METHODS

Cytogenetics

Three translocations, TR1,t(10;16)(q24.3;q22.1), TR2,t(5;16)(q14.2;q22.1), and TR3,t(2;16)(p15;q22.3), were identified in patients referred for chromosome studies. TR1 and TR3 were transformed using Epstein-Barr virus to produce permanent cell lines. GM1396 is a fibroblast line with karyotype 46,XY,der(10)t(10;16)(q26;q22) and was obtained from the NIGMS Human Genetic Mutant Cell Repository. Where possible, translocation breakpoints were defined using G-banding of prometaphase cells.

Metaphase spreads for *in situ* hybridization were prepared from lymphocyte cultures, fibroblast cultures, or lymphoblastoid cell lines. Chromosomes were either G-banded and photographed before *in situ* hybridization or banded after *in situ* hybridization (Zabel *et al.*, 1983).

The fragile site *FRA16B* at 16q22.100 was induced in lymphocyte cultures by growth in media for 6 h with 50 mg/liter BrdU (Sutherland *et al.*, 1984) or for 24 h with 150 mg/liter berenil (Sigma, St. Louis, MO), (Schmid *et al.*, 1986).

Mouse/Human Hybrids

A panel of mouse/human hybrids containing various segments of chromosome 16 has been described (Callen, 1986). Hybrid CY5 was derived from the cell line GM1396 and contains the der(10)t(10;16)(q26;q22). A new hybrid line, CY6, was derived from the lymphoblastoid line containing TR1. This hybrid contains the der(10)t(10;16)(q24.3;q22.1) and in addition human chromosome 8. Details of these and other hybrid lines are summarized in Table 1.

Probes

Details of the probes used are given in Table 2.

In Situ Hybridization

Probes were labeled with three tritiated nucleotides using an Amersham nick translation kit to specific activities of $1-7 \times 10^7$ cpm/ μ g. *In situ* hybridization was as previously described (Simmers *et al.*, 1986). Slides were developed after 1 to 5 weeks, depending on the relative probe concentration and the size of the probe. Individual grains were scored if they were positioned on or touching a chromosome.

The probes *D16S10* and *D16S11* contained repetitive DNA sequences and were pre-reassociated to a Cot200 prior to hybridization to metaphase chromosomes (Sealey *et al.*, 1985). This was achieved by mixing a 2000-fold excess of sonicated human DNA with the labeled probe in $5\times$ SSC. This DNA was incubated at 100°C for 10 min, chilled on ice for 1 min, incubated at 68°C for 3 h, and then added to the hybridization mix to a maximum probe concentration of 0.3 μ g/ml.

Southern Analysis

Techniques were as previously described (Hyland *et al.*, 1988a).

RESULTS

Partial karyotypes illustrating the four translocations with breakpoints in 16q22 are given in Fig. 1. In the case of TR1 the derived chromosome 16 shows a very small light band between the 16q21 dark band

TABLE 2
DNA Probes

Locus	Probe	Insert size (kb)	Origin	Ref.
<i>D16S4</i>	ACH207	4.7	Flow purified library	(8)
<i>D16S6</i>	16B11	3.7	Flow purified library	(8)
<i>D16S10</i>	ACHF3	12.5	Hybrid cell library	(22)
<i>D16S11</i>	ACHF4	8.5	Hybrid cell library	(22)
<i>CTRB</i>	pcXP33	0.3	Rat cDNA clone for chymotrypsinogen gene	(2)
<i>HP</i>	pULB1148	1.4	Human cDNA clone for haptoglobin gene	(20)
<i>LCAT</i>	pLCAT2	0.8	Human cDNA clone for lecithin:cholesterol acyltransferase gene	(23)
<i>TAT</i>	pcTAT-3	0.6	Rat cDNA clone for tyrosine aminotransferase gene	(15)

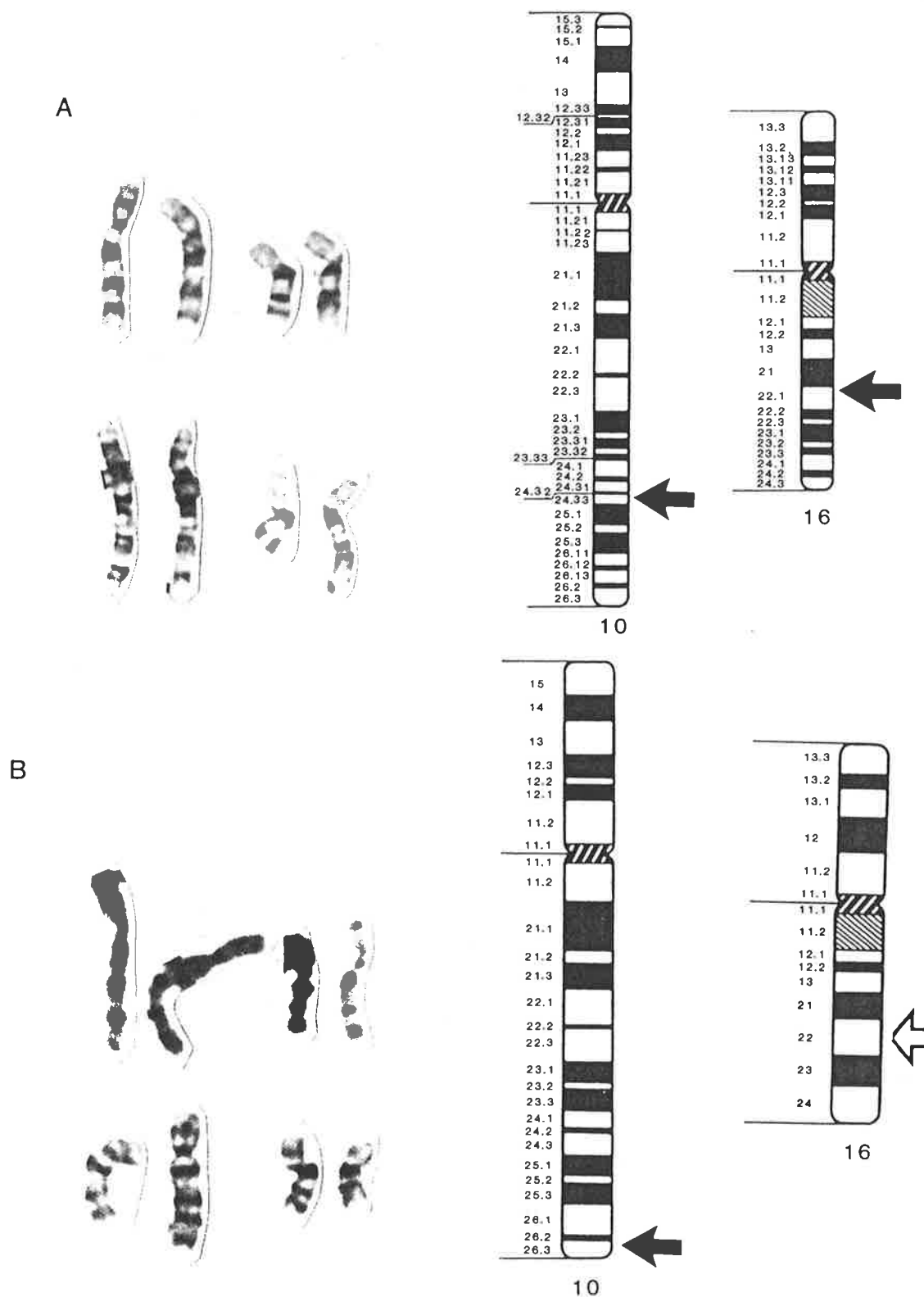

FIG. 1. Partial karyotypes of four translocations with breakpoints at 16q22. For each translocation two partial karyotypes are shown. For each pair of chromosomes the normal chromosome is on the left and the derived chromosome on the right. The ideogram (ISCN, 1985) is of the two normal chromosomes involved with breakpoints indicated by arrows. All are balanced translocations except for GM1396 (B) where the karyotype is 46,der(10)t(10;16). In this case the breakpoint of chromosome 16 is indicated by the open arrow. (A) TR1, t(10;16)(q24.3;q22.102). (B) GM1396, der(10)t(10;16)(q26.3;q22.105). (C) TR2, t(5;16)(q14.2;q22.108). (D) TR3, t(2;16)(p15;q22.3).

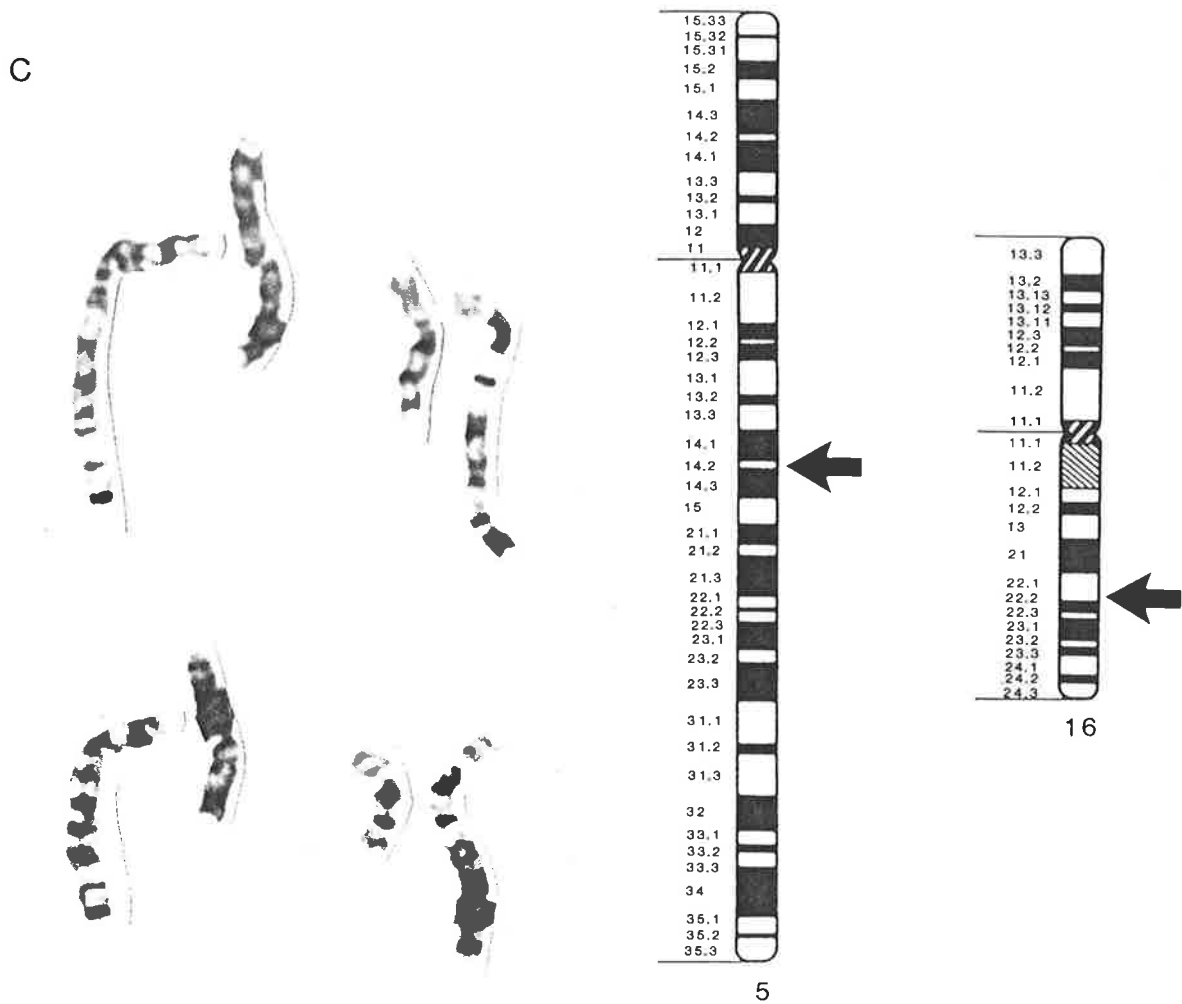

FIG. 1—Continued.

and the 10q25.1 dark band (Fig. 1A). Therefore the break on 16q22 was in the proximal portion of 16q22 at 16q22.102. GM1396 was a fibroblast line with a $\text{der}(10)\text{t}(10;16)$ and two normal chromosome 16's. The breakpoint on chromosome 10 was at the distal tip of the long arm at 10q26.3 (Fig. 1B), and the breakpoint on chromosome 16 was considered to be at 16q22.105. The breakpoints of TR2 were interpreted to be at 5q14.2 and at 16q22.108, with the derived chromosome 5 showing close juxtaposition of bands 5q14.1 and 16q22.2 (Fig. 1C). The band 5q14.3 is present as a fine band in the derived chromosome 16 between the 16q21 and the 5q21 dark bands. Breakpoints of the translocation TR3 were considered to be at 2p15 and 16q22.3. The derived chromosome 16 shows a small dark band between 16q21 and 2p16.1 (Fig. 1D). The distance between this fine band and 2p16.1 over a number of metaphases was not consis-

tent with this band being 2p14. This band was interpreted as being 16q22.2 and the breakpoint on chromosome 16 at 16q22.3 such that the derived chromosome 2 shows a close juxtaposition between the dark bands 2p14 and 16q23.

Hybridization results with probes *D16S4* (Fig. 2A), *CTRB*, *LCAT* (Fig. 2B), and *TAT* to genomic blots derived from various mouse/human hybrids are summarized in Table 3. Bands were identified as mouse or human by comparison of those appearing in the lane containing DNA from the mouse cell line (used to construct the hybrids) to those from human DNA. A number of polymorphic human bands were seen with the *CTRB* gene probe and these polymorphisms have been reported by Nicholls and Reeders (1988). These data show that *D16S4* and *LCAT* were localized to 16q13 → q22.102 and *CTRB* and *TAT* were localized to 16q22.105 → q24.

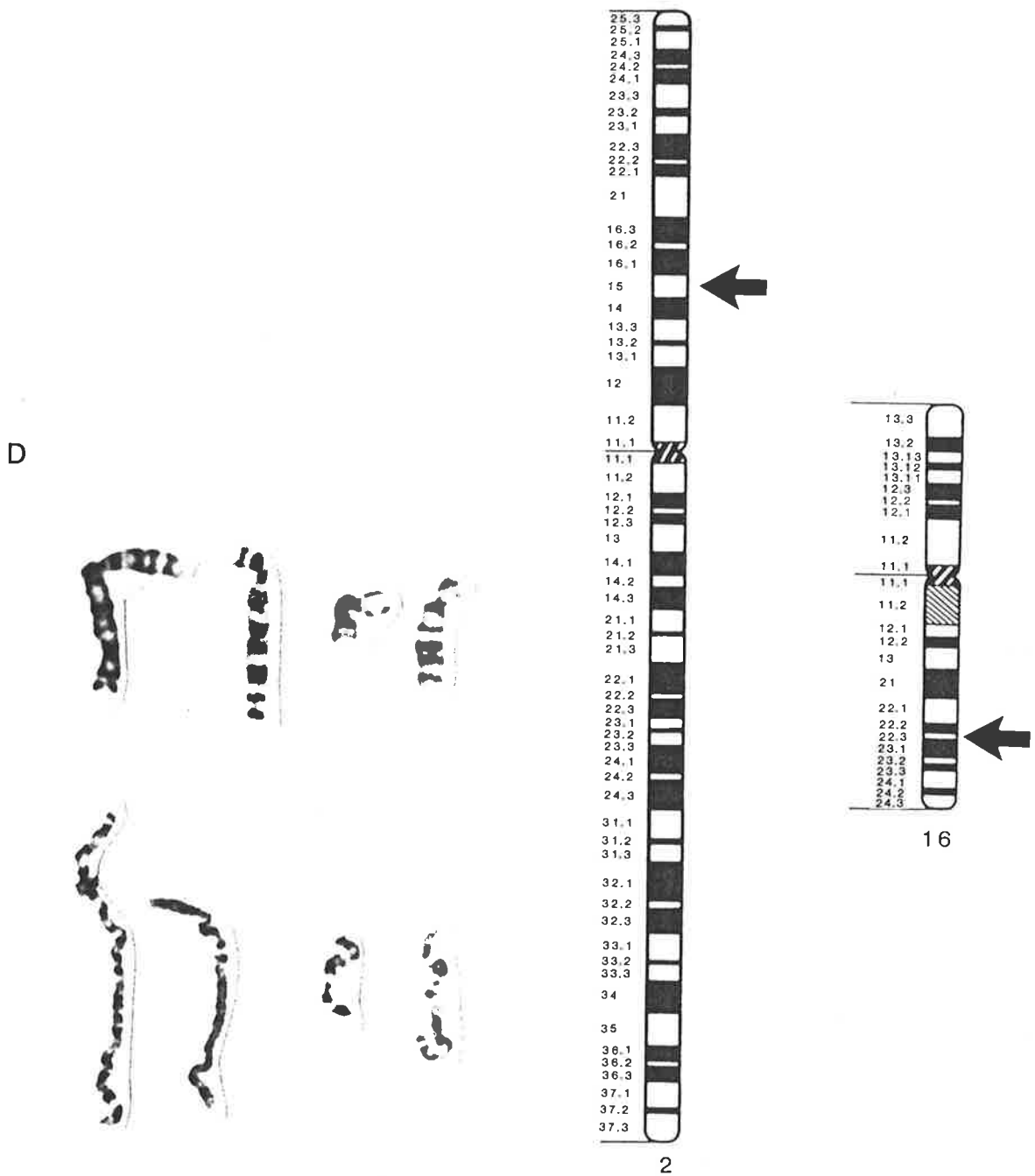

FIG. 1—Continued.

The probes for *LCAT*, *D16S4*, and *D16S6* were hybridized to chromosomes expressing *FRA16B*. Since *FRA16B* is not expressed in every cell, the time before development of the slides was selected to give a high signal on chromosome 16. In such cases the background signal on other chromosomes may be rela-

tively high compared with that acceptable when localizing an unmapped probe. For example, probe *D16S6* was scored when there was an average of 0.55 grain on the long arm of each chromosome 16 and an average 5.2 grains on the remaining chromosomes of the diploid set.

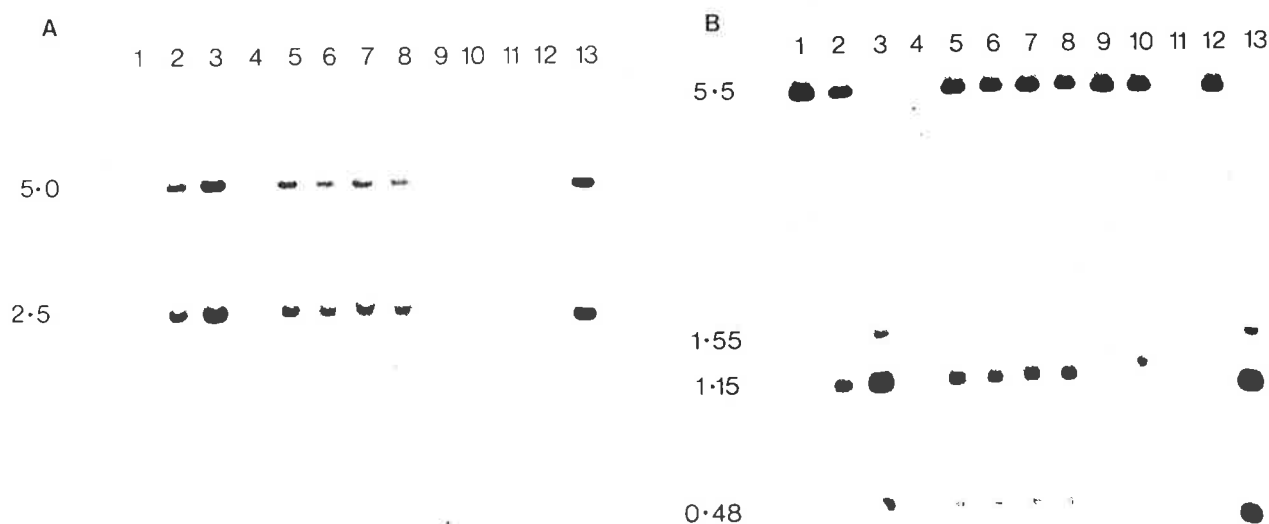

FIG. 2. Localization of clones to intervals on chromosome 16 by Southern blot hybridization of DNA from cell lines. The panel contained *TaqI*-digested DNA of A9, mouse parent (lane 1), CY18 (lane 2), human (lanes 3 and 13), CY3 (lane 5), CY13 (lane 6), CY16 (lane 7), CY7 (lane 8), CY6 (lane 9), CY5 (lane 10), and CY2 (lane 12). The panel was hybridized with (A) *D16S4* and (B) *LCAT*. *EcoRI*-digested SPP-1 standards were present in lanes 4 and 11 and were used to determine kilobase sizes.

Since the chromosome locations of these probes were known, only the distributions of grains on the long arm of chromosome 16 were scored (Table 4). Hybridizations with the probe for *D16S6* showed a significant excess of grains on the proximal side of the fragile site. Those grains counted in the central region or distal to the fragile site can be considered to be a combination of background and the spread of grains due to emission scatter from the site of probe hybridization. The probes *D16S4* and *LCAT* showed a distribution of grains consistent with these genes being localized distal to the fragile site (Table 4). Therefore, these data, in combination with the Southern blot analysis, localized *D16S6* to 16q13 → q22.100 and *D16S4* and *LCAT* to 16q22.100 → q22.102.

Initial data from hybridizations using the *D16S10* probe to chromosomes expressing *FRA16B* demon-

strated grains distributed on either side of this fragile site. To explore the possibility that this probe was split by the fragile site, grains were scored in metaphases where the gap at the fragile site was less than or equal to the width of the chromatid and in cases where the gap was greater than the width of the chromatid (Fig. 3). In the former situation, signal was scored on either side of the fragile site, with the ratio of the number of grains proximal to the number of grains distal not significantly different from a 1:1 ratio. However, when the gap was wider, the number of distal grains reduced to levels where the data were significantly different from a 1:1 ratio. Hybridizations with the *D16S11* probe to chromosomes expressing *FRA16B* were scored similarly. In this case varying widths of the fragile site did not influence the distri-

TABLE 3
Summary of Mapping Using Cell Lines

Probe	Human specific <i>TaqI</i> DNA (kb)	A9	Human	CY18	CY16	CY3	CY13	CY7	CY6	CY5	CY2	Location on chromosome 16
<i>D16S4</i>	5.0, 2.5	-	+	+	+	+	+	+	-	-	-	16q13 → q22.102
<i>CTRB</i>	1.75, 1.10, 1.05, 0.92, 0.82	-	+	+	+	+	+	+	+	+	-	16q22.105 → q24
<i>LCAT</i>	1.55, 1.15, 0.48	-	+	+	+	+	+	+	-	-	-	16q13 → q22.102
<i>TAT</i>	21.0	-	+	+	+	+	+	+	+	+	-	16q22.105 → q24

Note. When hybridization corresponding to a human band is present, this is indicated by "+". A "-" indicates hybridization to human bands was absent.

bution of grains (Fig. 3) with both situations showing a significant excess of grains proximal to *FRA16B*. These data indicate that *D16S10* and *D16S11* are both proximal to *FRA16B* in the region 16q13 → q22.100. *D16S10* may be located distal to *D16S11*.

The results of hybridizations of *HP*, *TAT*, and *D16S4* to various translocations with breakpoints within 16q22 are given in Fig. 4. This was undertaken to confirm the results from Southern analysis and to allow further localization. In addition, these data also provided confirmation of the ordering of the breakpoints of translocations in 16q22 based on cytogenetic analysis. The results with *D16S4* show that in 56 metaphases with the TR1 translocation the number of grains on chromosome 10q and the der(10q) were consistent with the background grain distribution. There is a significant label present on the normal chromosome 16q and on the der(16q). Therefore, the break in this translocation was distal to the locus of *D16S4*, resulting in this gene remaining on the derived chromosome 16. GM1396, TR2, and TR3 all had breaks which were demonstrated cytogenetically to be distal in 16q22 to the breakpoints of TR1. Therefore a significant label would only be predicted on the derived chromosome 16 and this was found to be the case. The GM1396 line contains two normal chromosome 16's and a der(10)t(10;16), with the der(16)t(10;16) being absent. These results locate *D16S4* to the region between *FRA16B* located at 16q22.100 and the breakpoint of TR1 at 16q22.102 and so confirms the results from Southern analysis.

When the *HP* probe was hybridized to chromosomes from TR1 and GM1396, both the derived chromosome 10's showed a significant label. Therefore the breakpoints of these two translocations on chromosome 16 were proximal to the *HP* locus. Results with TR2 and TR3 showed a significant label on the derived chromosome 16 and therefore the breakpoints of these two translocations were distal

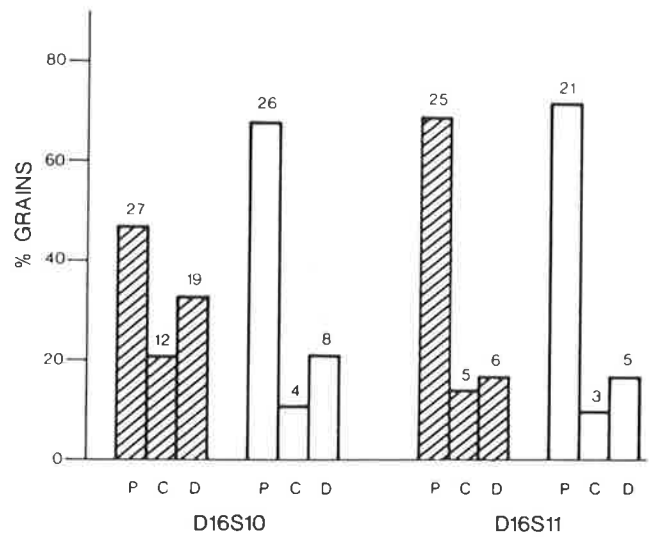

FIG. 3. *In situ* hybridization of *D16S10* and *D16S11* to *FRA16B*. The hatched histograms represent grains scored on chromosome 16's where the gap at the fragile site is less than or equal to the width of a chromatid. The nonhatched histograms represent cases where the gap of the fragile site is greater than the width of a chromatid. The positions of grains relative to the fragile site are given by P, proximal; D, distal; and C, central. The numbers on top of each column give the total number of grains scored in that category.

to the *HP* locus. Therefore *HP* is localized to 16q22.105 → q22.108.

The *TAT* probe used was isolated from the rat. Hybridizations using this probe required probe concentrations and exposure times which resulted in a background relatively higher than that with *D16S4* and *HP*. This is likely to be due to the lack of complete homology between this rat probe and the human gene sequence. The hybridizations with *TAT* showed results similar to those with *HP*, with a localization to 16q22.105 → q22.108, and again confirms the results from Southern analysis.

DISCUSSION

The two anonymous DNA fragments, *D16S10* and *D16S11*, had previously been located in the region 16q13 → q22.105 by probing genomic filters of mouse/human hybrids containing portions of chromosome 16 (Sutherland *et al.*, 1987). This study refines their location by *in situ* hybridization to a position proximal to *FRA16B*, that is, in the region 16q13 → q22.100. Scoring the distribution of grains distal, central, and proximal to the fragile site on chromosomes where the gap of the fragile site was less than the width of a chromatid, and comparing that distribution with the distribution of grains when the

TABLE 4

In Situ Hybridization of *LCAT*, *D16S4*, and *D16S6* to *FRA16B*

Probe	Number of cells		Distribution of grains at <i>FRA16B</i>		
	Without <i>FRA16B</i>	With <i>FRA16B</i>	Distal	Central	Proximal
<i>LCAT</i>	9	93	37	3	12
<i>D16S4</i>	479	298	82	27	28
<i>D16S6</i>	35	67	1	4	22

Note. The *FRA16B* was induced by growth of lymphocytes in BrdU for *D16S4* and *D16S6* and in berenil for *LCAT*.

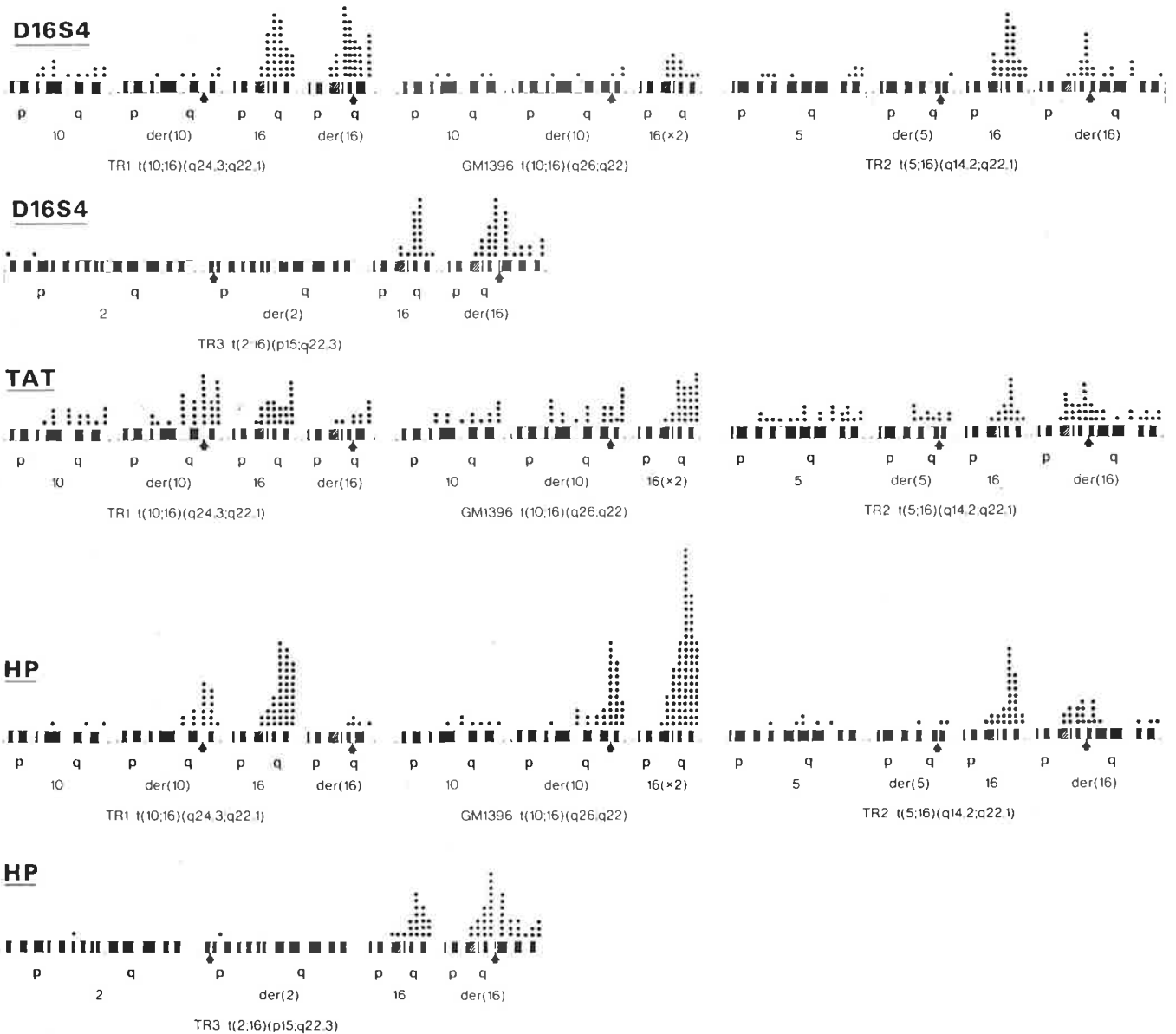

FIG. 4. *In situ* hybridization of *HP*, *TAT*, and *D16S4* to various translocations. For each translocation, ideograms of the chromosomes (ISCN, 1985) are in the order of a normal autosome involving other than chromosome 16, the derived version of this autosome, normal 16, and derived 16. In the case of GM1396 only the derived chromosome 10 is present and the grains on chromosome 16 represent the total on both intact 16's found in this cell line. Arrows indicate positions of translocation breakpoints. Only those grains on the arms of chromosomes involved in the translocations are given. The total numbers of metaphases scored to obtain the presented grain distribution for TR1, GM1396, TR2, and TR3, respectively, are 56, 23, 72, and 62 for *D16S4*; 95, 85, and 89 for *TAT*; and 30, 34, 33, and 48 for *HP*.

gap was greater than the width of a chromatid, suggested that *D16S10* may be closer to *FRA16B* than *D16S11*. The interpretation of grains on either side of a fragile site has been considered in detail by Simmers *et al.* (1987).

Results of *in situ* hybridization of *D16S4*, *HP*, and *TAT* to four different translocations provided confirmation of the order of the breakpoints in 16q22 as

determined by the cytogenetics. If the cytogenetic breakpoint determinations were incorrect, then there would be a lack of consistency in the *in situ* hybridization data. For example, the hybridizations with the three probes were all consistent in showing that the breakpoints of TR2 and TR3 in 16q22 were distal to these three probes. Similarly, the breakpoint of TR1 on 16q22 was proximal to both *TAT* and *HP*. How-

ever, there is an inherent uncertainty in the exact position of the breakpoints in band 16q22 since they are determined solely from interpreting cytogenetic data.

The combination of Southern analysis using a chromosome 16 hybrid cell panel, *in situ* hybridization to four different translocations with breakpoints in 16q22, and hybridization to metaphase chromosomes expressing *FRA16B* was successful in enabling a detailed physical map of this region (Fig. 5). The *CTRB* gene has previously been located at 16q11 → q22 (Nicholls and Reeders, 1988). This study gives a location distal to 16q22.105. Therefore the shortest region of overlap is the distal half of 16q22. The order of gene probes and anonymous DNA fragments from these data is centromere-*D16S6*, *D16S11*, *D16S10*, *MT*-*FRA16B*-*D16S4*, *LCAT*-*HP*, *TAT*, *CTRB*-*APRT*-telomere. Probes to the metallothioneine gene cluster, *MT*, have previously been located just proximal to *FRA16B* and *FRA16C* (Simmers *et al.*, 1987) and *APRT* has been located in distal 16q24 (Fratini *et al.*, 1986).

For the probes *MT*, *D16S4*, and *D16S10* restriction fragment length polymorphisms have now been described (Hyland *et al.*, 1987, 1988b; Sutherland *et al.*, 1987). Estimation of the genetic distance between these markers and between *FRA16B* is in progress.

The mapping of the *LCAT* gene probe and *D16S4* to the same small physical region creates a potential use

for *D16S4* in the prenatal diagnosis and carrier detection of the rare *LCAT* deficiency disease. The *LCAT* probe is not polymorphic, whereas *D16S4* shows two *Msp*I and a *Taq*I polymorphism (PIC values 0.27, 0.35, and 0.30, respectively; Hyland *et al.*, 1988b).

The technique of *in situ* hybridization is usually considered to allow resolution of probe localizations to a minimum of a single G-band. However, as this study demonstrates, the use of fixed structural alterations on chromosomes, for example, fragile sites or translocations, allows a considerable increase in this resolution. The resolution is limited only by access to structural rearrangements with a spectrum of breakpoints in the region of interest. Cooke *et al.* (1987), in a flow karyotype analysis of a patient with a deletion of half to two-thirds of 16q22, showed that this deletion was approximately 7000 kb. Consequently, the region spanned by *FRA16B* and the breakpoint of TR1 at 16q22.102 is probably on the order of 1000 to 2000 kb. Therefore, *in situ* hybridization can bridge the resolution gap between that usually provided by somatic cell hybrids and linkage analysis and that provided by pulsed-field gel electrophoresis.

ACKNOWLEDGMENTS

We thank the following people for generously supplying DNA probes—S. Reeders (16B11), G. F. Bell (pcXP33), A. van der Straeten (pULB1148), S. Humphries (pLCAT2), and G. Schutz (pcTAT-3). The assistance of Sharon Bain and Kerry Thorn is acknowledged. This work was supported by the National Health and Medical Research Council of Australia and the Adelaide Children's Hospital Research Trust.

REFERENCES

1. AZOULAY, M., HENRY, I., TATA, F., WEIL, D., GRZESCHIK, K. H., CHAVES, M. E., MCINTYRE, N., WILLIAMSON, R., HUMPHRIES, S. E., AND JUNIEN, C. (1987). The structural gene for human lecithin:cholesterol acyltransferase (*LCAT*) maps to 16q22. *Ann. Hum. Genet.* 51: 129-136.
2. BELL, G. I., QUINTO, C., QUIROGA, M., VALENZUELA, P., CRAIK, C. S., AND RUTTER, W. J. (1984). Isolation and sequence of a rat chymotrypsin B gene. *J. Biol. Chem.* 259: 14265-14270.
3. BERGER, R., BLOOMFIELD, C. D., AND SUTHERLAND, G. R. (1985). Report of the committee on chromosome rearrangements in neoplasia and on fragile sites: Eighth International Workshop on Human Gene Mapping. *Cytogenet. Cell Genet.* 40: 490-535.
4. CALLEN, D. F. (1986). A mouse-human hybrid cell panel for mapping human chromosome 16. *Ann. Genet.* 29: 235-239.
5. COOKE, A., TOLMIE, J., DARLINGTON, W., BOYD, E., THOMSON, R., AND FERGUSON-SMITH, M. A. (1987). Confirmation of a suspected 16q deletion in a dysmorphic child by flow karyotype analysis. *J. Med. Genet.* 24: 88-92.
6. FRATINI, A., SIMMERS, R. N., CALLEN, D. F., HYLAND, V. J.,

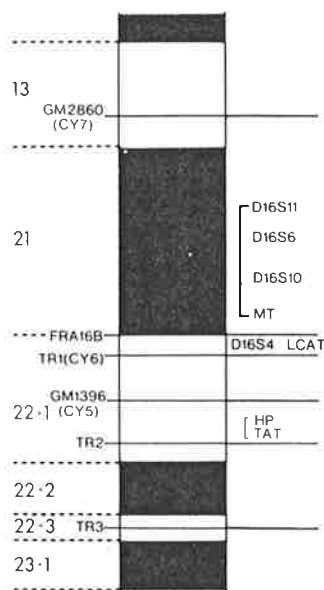

FIG. 5. Gene and anonymous DNA fragment localizations to the long arm of chromosome 16. TR1, GM1396, TR2, and TR3 refer to breakpoints of four translocations. CY5, CY6, and CY7 are mouse/human hybrids derived from translocations with breakpoints in the regions indicated (see Table 1).

- TISCHFIELD, J. A., STAMBROOK, P. J., AND SUTHERLAND, G. R. (1986). A new location for the human adenine phosphoribosyltransferase gene (*APRT*) distal to the haptoglobin (*HP*) and fra(16)(q23) (*FRA16D*) loci. *Cytogenet. Cell Genet.* **43**: 10-13.
7. HYLAND, V. J., GRIST, S., WEST, A., RICHARDS, R. I., AND SUTHERLAND, G. R. (1987). A 5' flanking region of the metallothionein, *MT2A*, gene identifies two moderately frequent RFLPs. *Nucleic Acids Res.* **15**: 1350.
8. HYLAND, V. J., GRIST, S., CALLEN, D. F., AND SUTHERLAND, G. R. (1988a). Anonymous DNA probes to human chromosome 16 derived from a flow-purified library. *Amer. J. Hum. Genet.* **42**: 373-379.
9. HYLAND, V. J., GRIST, S., AND SUTHERLAND, G. R. (1988b). Restriction fragment length polymorphisms detected by anonymous DNA probes mapped to defined intervals of human chromosome 16. *Hum. Genet.*, in press.
10. ISCN (1985). "An International System for Human Cytogenetic Nomenclature" (D. G. Harnden and H. P. Klinger, Eds.), published in collaboration with *Cytogenet. Cell Genet.*, Karger, Basel.
11. MAGENIS, R. E., HECHT, F., AND LOVRIEN, E. W. (1970). Heritable fragile site on chromosome 16: Probable localization of haptoglobin locus in man. *Science* **170**: 85-87.
12. MAGENIS, E., AND CHAMBERLIN, J. (1979). Location of fragile site: 16q22.00. *Cytogenet. Cell Genet.* **25**: 180.
13. NATT, E., KAO, F. T., RETTENMEIER, R., AND SCHERER, G. (1986). Assignment of the human tyrosine aminotransferase gene to chromosome 16. *Hum. Genet.* **72**: 225-228.
14. NICHOLLS, R. D., AND REEDERS, S. T. (1988). Unusual DNA polymorphism due to rearrangement of the chymotrypsinogen B gene on chromosome 16. Submitted for publication.
15. SCHERER, G., SCHMID, W., STRANGE, C. M., ROWEKAMP, W., AND SCHUTZ, G. (1982). Isolation of cDNA clones coding for rat tyrosine aminotransferase. *Proc. Natl. Acad. Sci. USA* **79**: 7205-7208.
16. SCHMID, M., FEICHTINGER, W., JESSERGER, A., KOHLER, J., AND LANGE, R. (1986). The fragile site (16)(q22). I. Induction by AT-specific DNA-ligands and population frequency. *Hum. Genet.* **74**: 67-73.
17. SEALEY, P. G., WHITTAKER, P. A., AND SOUTHERN, E. M. (1985). Removal of repeated sequences from hybridization probes. *Nucleic Acids Res.* **13**: 1905-1922.
18. SIMMERS, R. N., STUPANS, I., AND SUTHERLAND, G. R. (1986). Localization of the human haptoglobin genes distal to the fragile site at 16q22 using *in situ* hybridization. *Cytogenet. Cell Genet.* **41**: 38-41.
19. SIMMERS, R. N., SUTHERLAND, G. R., WEST, A., AND RICHARDS, R. I. (1987). The fragile sites at 16q22 are not at the breakpoint of the chromosomal rearrangement in AMMoL. *Science* **236**: 92-94.
20. STRATEN, A., HERZOG, A., JACOBS, P., CABEZON, T., AND BOLLEN, A. (1983). Molecular cloning of human haptoglobin cDNA: Evidence for a single mRNA coding for α , α^2 , and β chains. *EMBO J.* **2**: 1003-1007.
21. SUTHERLAND, G. R., JACKY, P. B., AND BAKER, E. G. (1984). Heritable fragile sites on human chromosomes. XI. Factors affecting expression of fragile sites at 10q25, 16q22 and 17p12. *Amer. J. Hum. Genet.* **36**: 110-122.
22. SUTHERLAND, G. R., REEDERS, S., HYLAND, V. J., CALLEN, D. F., FRATINI, A., AND MULLEY, J. C. (1987). Molecular genetics of human chromosome 16. *J. Med. Genet.* **24**: 451-456.
23. TATA, F., CHAVES, M. E., MARKHAM, A. F., SCRACE, G. D., WATERFIELD, M. D., MCINTYRE, N., WILLIAMSON, R., AND HUMPHRIES, S. E. (1987). The isolation and characterization of cDNA and genomic clones for human lecithin:cholesterol acyltransferase. *Biochim. Biophys. Acta* **910**: 142-148.
24. ZABEL, B. U., NAYLOR, S. L., SAKAGUCHI, A. Y., BELL, G. I., AND SHOWS, T. B. (1983). High resolution chromosomal localization of human genes for amylase, proopiomelanocortin, somatostatin, and a DNA fragment (D3S1) by *in situ* hybridization. *Proc. Natl. Acad. Sci. USA* **80**: 6932-6936.

ACHF249 (D22S14) detects a common PstI RFLP and maps at 22cen->22q13.1.

A.Fratini, E.G.Baker, D.F.Callen, V.J.Hyland and G.R.Sutherland.

Cytogenetics Unit, Department of Histopathology, Adelaide Children's Hospital, North Adelaide, South Australia 5006 (Australia).

SOURCE AND DESCRIPTION OF CLONE: ACHF249 (D22S14) was isolated from an EcoRI λ Charon 4A library as previously described (Fratini *et al.*, 1988). ACHF249 contains a 15.0 kb insert that contains repetitive sequences.

POLYMORPHISM: PstI two invariant bands at 9.5 and 5.0 kb and a two-allele polymorphism with bands at either 9.4 kb (A1) or at 5.4 and 4.0 kb (A2).

FREQUENCY: Studied in 20 unrelated Caucasians.

9.4 kb allele (A1) 0.58

5.4, 4.0 kb allele (A2) 0.42; PIC value = 0.37

NOT POLYMORPHIC FOR: BglIII, EcoRI, HindIII, MspI and TaqI, with a panel of 6 unrelated individuals.

CHROMOSOMAL LOCALISATION: Located to chromosome 22 on the basis of a Southern blot hybridization signal to the single human chromosome 22/mouse hybrid WEGROTH-D2 (A. Geurts van Kessel) and by *in situ* hybridisation to t(6;22)(p21.3;q13.1), mapping the probe to 22cen->22q13.1.

MENDELIAN INHERITANCE: Codominant inheritance was shown in UTAH Family 984.

PROBE AVAILABILITY: Available on a collaborative basis from G.R. Sutherland.

OTHER COMMENTS: Probe requires pre-reassociation with sonicated human genomic DNA.

REFERENCE: Fratini *et al.* (1988), Nucleic Acids Res.¹

ACKNOWLEDGEMENTS: Supported by the National Health and Medical Research Council of Australia and the Adelaide Children's Hospital Research Foundation.

¹ refers to the third RFLP report in this series.

pACHF1.1 (D16S8) detects a common PvuII RFLP and maps at 16p13.3->16p13.11.

A.Fratini¹, E.G.Baker¹, D.F.Callen¹, S.Reeders², V.J.Hyland¹ and G.R.Sutherland¹.

¹Cytogenetics Unit, Department of Histopathology, Adelaide Children's Hospital, North Adelaide, South Australia 5006 (Australia), and
²Department of Nephrology 2073 LMP, Yale University School of Medicine, New Haven CT 06510, USA.

SOURCE AND DESCRIPTION OF CLONE: ACHF1 (D16S8) was isolated from an EcoRI λ Charon 4A library as previously described (Fratini *et al.*, 1988). A 1.7 kb EcoRI-XbaI human insert from ACHF1, has been subcloned into pUC18. The clone contains repetitive sequences.

POLYMORPHISM: PvuII identifies a two-allele polymorphism with bands at either 3.8 kb (A1) or 2.2 kb (A2).

FREQUENCY: Studied in 26 unrelated Caucasians.

3.8 kb allele (A1) 0.52

2.2 kb allele (A2) 0.48; PIC value = 0.38

NOT POLYMORPHIC FOR: BamHI, BanII, BclI, BglII, EcoRI, HincII, HindIII, HinfI, MspI, PstI, RsaI and TaqI, with a panel of 6 unrelated individuals.

CHROMOSOMAL LOCALISATION: Localised to 16p13.3->16p13.11 using a panel of somatic cell hybrids (Callen, 1986) and by *in situ* hybridisation as distal to FRA16A.

MENDELIAN INHERITANCE: Codominant inheritance was shown in UTAH Family 982.

PROBE AVAILABILITY: Available on a collaborative basis from G.R. Sutherland.

OTHER COMMENTS: Probe requires pre-reassociation with sonicated human genomic DNA.

REFERENCES: Callen (1986), *Ann. Genet.* 29 : 235-239.¹
Fratini *et al.* (1988), *Nucleic Acids Res.*¹

ACKNOWLEDGEMENTS: Supported by the National Health and Medical Research Council of Australia and the Adelaide Children's Hospital Research Foundation.

¹ refers to the third RFLP report in this series.

RsaI and TaqI RFLPs for pACHF3.5 (D16S10).

A.Fratini, E.G.Baker, D.F.Callen, V.J.Hyland and G.R.Sutherland.

Cytogenetics Unit, Department of Histopathology, Adelaide Children's Hospital, North Adelaide, South Australia 5006 (Australia).

SOURCE AND DESCRIPTION OF CLONE: ACHF3 (D16S10) was isolated from an EcoRI λ Charon 4A library constructed from a mouse-human hybrid cell line (WAIVA) containing human chromosomes 16 and 22 (Deisseroth et al., 1977). A unique 3.5 kb XbaI fragment was subcloned from ACHF3 into pSP64, and named pACHF3.5.

POLYMORPHISMS: RsaI identifies one invariant band at 0.8 kb and a two-allele polymorphism with bands at either 2.6 kb (B1) or 1.84 and 0.76 kb (B2). TaqI identifies one invariant band at 4.5 kb and a two-allele polymorphism with bands at either 1.3 kb (A1) or 5.4 kb (A2).

FREQUENCY: RsaI RFLP, studied in 21 unrelated Caucasians.
2.6 kb allele (B1) 0.71
1.84, 0.76 kb allele (B2) 0.29; PIC value = 0.33
TaqI RFLP, studied in 20 unrelated Caucasians.
1.3 kb allele (A1) 0.62
5.4 kb allele (A2) 0.38; PIC value = 0.36

NOT POLYMORPHIC FOR: BamHI, BanII, BclI, BglI, BglIII, BstNI, BstXI, DraI, EcoRI, EcoRV, HaeIII, HincII, HindIII, HinfI, KpnI, MspI, NsiI, PstI, PvuII, SacI and XbaI, with a panel of 6 unrelated individuals.

CHROMOSOMAL LOCALISATION: Localised to 16q13- \rightarrow 16q22.1 using a panel of somatic cell hybrids (Callen, 1986) and by in situ hybridisation as proximal to FRA16B.

MENDELIAN INHERITANCE: Codominant inheritance for RsaI and TaqI RFLPs was shown in UTAH Family 985.

PROBE AVAILABILITY: Available on a collaborative basis from G.R. Sutherland.

OTHER COMMENTS: The A1, B1 and A2, B2 alleles were co-inherited in 28 unrelated individuals, A1B2 and A2B1 haplotypes were not found, indicating linkage disequilibrium.

REFERENCES: Callen (1986), *Ann. Genet.* 29 : 235-239.
Deisseroth et al. (1977), *Cell* 12 : 205-218.

ACKNOWLEDGEMENTS: Supported by the National Health and Medical Research Council of Australia and the Adelaide Children's Hospital Research Foundation.