



**LANDFORM DEVELOPMENT AND STREAM BEHAVIOUR IN THE WESTERN  
PIEDMONT ZONE OF THE FLINDERS RANGES OF SOUTH AUSTRALIA**

**JENNIFER A. BOURNE**

**M. A. (Adelaide)**

**Thesis submitted for the degree of**

**Doctor of Philosophy**

**in**

**The University of Adelaide**

**(Faculty of Science)**

**February 1996**

## TABLE OF CONTENTS

LIST OF TABLES	i
LIST OF FIGURES	ii
ABSTRACT	viii
DECLARATION	x
ACKNOWLEDGEMENTS	xi
<b>CHAPTER ONE</b>	<b>1</b>
<b>THE WESTERN PIEDMONT OF THE FLINDERS RANGES, SOUTH AUSTRALIA</b>	
I. THE PROBLEM	1
II. PLAN OF THE THESIS	2
III. STRUCTURAL FRAMEWORK OF THE FLINDERS RANGES AND THE TORRENS PLAIN	3
A. FLINDERS RANGES AND ENVIRONS	3
B. PIRIE-TORRENS BASIN	6
1. Tertiary Sub-basins	8
2. Lake Torrens	9
(a) Age of the piedmont landform assemblages	10
(b) Regional baselevel	11
C. DEVELOPMENT OF SPENCER GULF	12
IV. CONCLUSION	13
<b>CHAPTER TWO</b>	<b>14</b>
<b>PEDIMENTS AND ALLUVIAL FANS: LITERATURE REVIEW AND CRITIQUE</b>	
I. INTRODUCTION	14

II.	PEDIMENTS	14
	A. GENERAL STATEMENT	14
	B. MORPHOLOGY	16
	1. General Statement	16
	2. Areal Extent	16
	3. Piedmont Angle	17
	4. Pediment Surface	19
	5. Shape and Transverse Profile	20
	6. Longitudinal Profile	20
	C. ORIGIN OF PEDIMENTS	22
III.	ALLUVIAL FANS	25
	A. GENERAL STATEMENT	25
	B. MORPHOLOGY	26
	1. General Statement	26
	2. Fan Deposits	27
	3. Fan Size	28
	4. Fan Slope	28
	C. ORIGIN OF ALLUVIAL FANS	30
	D. ALLUVIAL FAN DISSECTION	31
IV.	COEXISTENCE OF PEDIMENTS AND ALLUVIAL FANS	31
	<b>CHAPTER THREE</b>	<b>34</b>
	<b>PEDIMENTS IN THE WESTERN PIEDMONT OF THE FLINDERS RANGES</b>	
I.	INTRODUCTION	34
II.	REGIONAL ACCOUNTS	35
	A. PARACHILNA-EDEOWIE REGION	35
	1. Pediments	35
	(a) Main Pediment	35
	(i) Shape	35
	(ii) Length	36

(iii)	Piedmont Angle	36
(iv)	Slope	37
(v)	Pediment Cover	37
(b)	High Pediment	39
(i)	Bundulla-Walkandi High Pediment	39
(ii)	Bunyeroo 'High' Pediment	40
(c)	Modern Pediments	41
(d)	Riverine Outwash Plains	42
2.	Drainage Basins	43
B.	WYACCA-EMEROO REGION	44
1.	Pediments	44
(a)	Pediments of the Wyacca and Emeroo Ranges	45
(b)	Pediment Remnants of the Central Section	46
2.	Drainage Basins	47
III.	ORIGIN OF THE PEDIMENTS	47
IV.	AGE OF THE PEDIMENTS	50
V.	CONCLUDING STATEMENT	50
	<b>CHAPTER FOUR</b>	<b>52</b>
	<b>ALLUVIAL FANS IN THE WESTERN PIEDMONT OF THE FLINDERS RANGES</b>	
I.	INTRODUCTION	52
II.	REGIONAL ACCOUNTS	53
A.	PARACHILNA-EDEOWIE REGION	53
1.	General Statement	53
2.	Parachilna Alluvial Fan	54
(a)	Dimensions	54
(b)	Deposits	54
(c)	Slope and Surface	55
3.	Drainage Basin	55

4.	Brachina-Bunyeroo Alluvial Fan	56
	(a) Dimensions	56
	(b) Deposits	56
	(c) Slope and Surface	57
5.	Drainage Basins	57
6.	Minor Alluvial Fans	58
7.	Riverine Outwash Plains	59
B.	WYACCA-EMEROO REGION	60
1.	General Statement	60
2.	Alluvial Fans	60
	(a) Dimensions	60
	(b) Deposits	61
	(c) Slope and Surface	62
	(d) Segments	63
	(i) Main Surface	63
	(ii) Bar and Pavement Surface	64
	(iii) Bar and Channel Surface	65
	(iv) Significance of Alluvial Soil Colours	65
3.	Drainage Basins	67
	(a) Dimensions	67
	(b) Drainage Pattern	68
	(c) Sediment Supply	69
4.	Minor Alluvial Fans	71
III.	DISSECTION AND DATING OF THE ALLUVIAL FANS	71
IV.	CONCLUDING STATEMENT	72
	<b>CHAPTER FIVE</b>	<b>74</b>
	<b>PEDIMENTS AND ALLUVIAL FANS: GENESIS AND RELATIONSHIPS IN THE WESTERN PIEDMONT OF THE FLINDERS RANGES</b>	
I.	STATEMENT OF PROBLEM	74

II.	DISTRIBUTION OF THE PEDIMENTS AND ALLUVIAL FANS	74
	A. GENERAL STATEMENT	74
	B. EVOLUTIONARY SCHEME	75
	C. INCIPIENT PEDIMENTS OR ALLUVIAL FANS?	78
	D. MAJOR ALLUVIAL FANS AND SHIFTS IN BASELEVEL	78
III.	AGE RELATIONS OF THE PEDIMENTS AND ALLUVIAL FANS	79
IV.	PROCESSES RESPONSIBLE FOR THE PEDIMENTS AND ALLUVIAL FANS	80
V.	RELATIONSHIPS BETWEEN THE PEDIMENTS AND ALLUVIAL FANS	81
	A. GENERAL STATEMENT	81
	B. ALIENA WASHOUT	81
	1. General Statement	81
	2. Pediments	82
	(a) Rock Pediment	82
	(b) Covered Pediment	82
	(c) High Pediment	83
	3. Alluvial Fan	84
	4. Drainage Basin	84
	5. Implications for Landform Assemblages of the Study Area	84
VI.	CONTRIBUTION TO THE STUDY OF PEDIMENTS AND ALLUVIAL FANS	85
VII.	CONCLUDING STATEMENT	89

**APPENDIX I: THE IDENTIFICATION AND DISTRIBUTION OF PEDIMENTS AND ALLUVIAL FANS IN THE WESTERN PIEDMONT OF THE FLINDERS RANGES, SOUTH AUSTRALIA**

**A. GENERAL STATEMENT**

**B. METHODS USED TO DISTINGUISH PEDIMENTS AND ALLUVIAL FANS**

1. Thickness of the Alluvial Deposits
2. Remote Sensing
3. Contour Pattern
4. Drainage Texture
5. Catchment Characteristics
6. Length
7. Other Criteria
  - (a) Bedrock Hills and Ridges
  - (b) Slope
  - (c) Relief Amplitude and/or Highest Points in Drainage Basin
  - (d) Ruggedness of Drainage Basin
  - (e) Granulometric Measurement of Surface Deposits

**C. CONCLUDING STATEMENT**

**APPENDIX II: REGRESSION ANALYSIS: CHARACTERISTICS OF PEDIMENTS AND ALLUVIAL FANS**

**APPENDIX III: SHALLOW SEISMIC REFRACTION SURVEY: HAYWARD PEDIMENT**

**APPENDIX IV: RAINFALL EVENTS IN THE FLINDERS RANGES REGION**

- A. GENERAL STATEMENT
- B. RAINFALL RECORDS FOR THE FLINDERS RANGES REGION
- C. STREAM DISCHARGE RECORDS
- D. DISCUSSION

**APPENDIX V: BOULDER MEASUREMENTS: MAJOR ALLUVIAL FANS, WYACCA-EMEROO REGION**

**APPENDIX VI: X-RAY DIFFRACTION ANALYSIS OF SOIL SAMPLES: MAJOR ALLUVIAL FANS, WYACCA-EMEROO REGION**

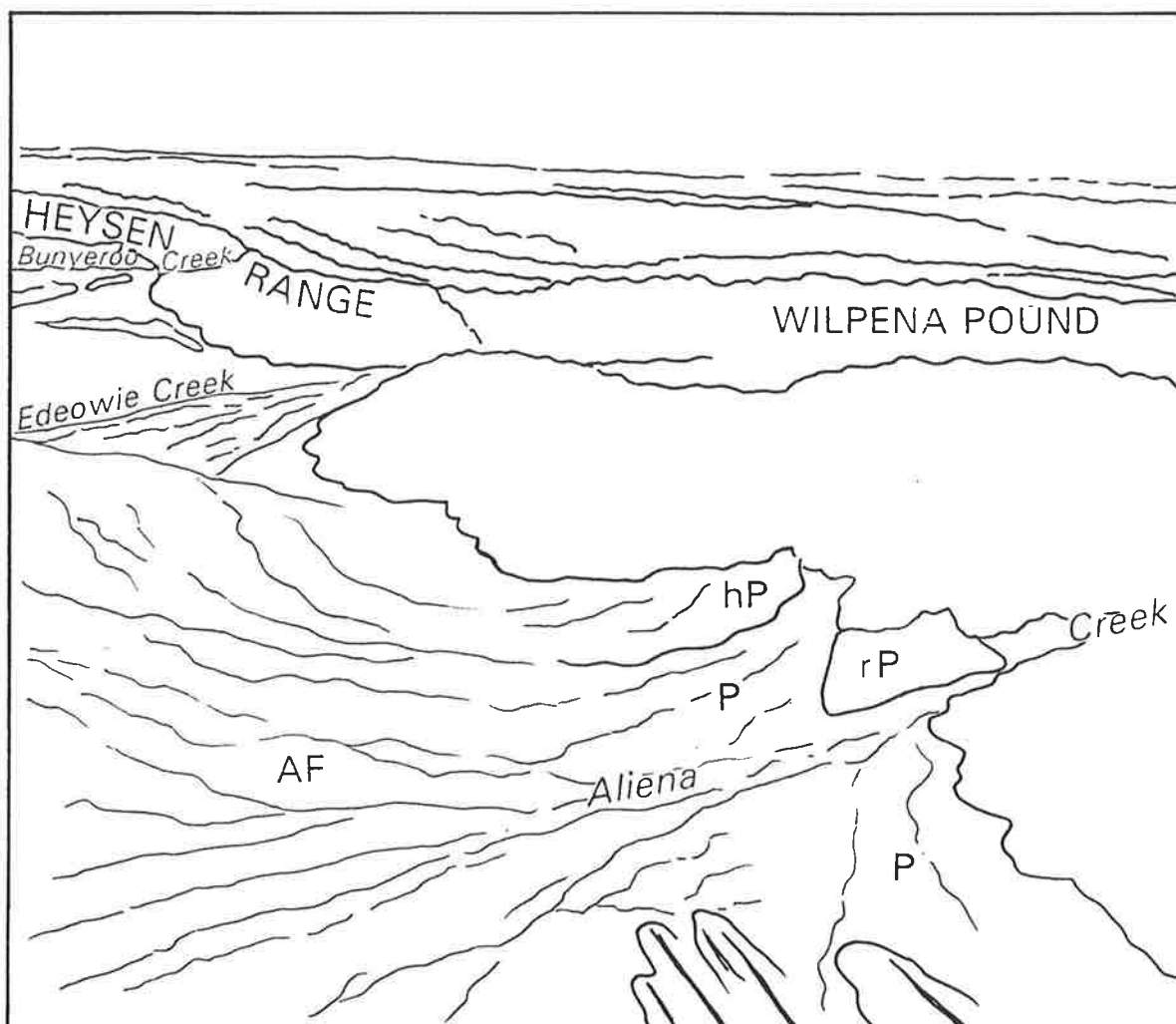
**BIBLIOGRAPHY**

**FIGURES**

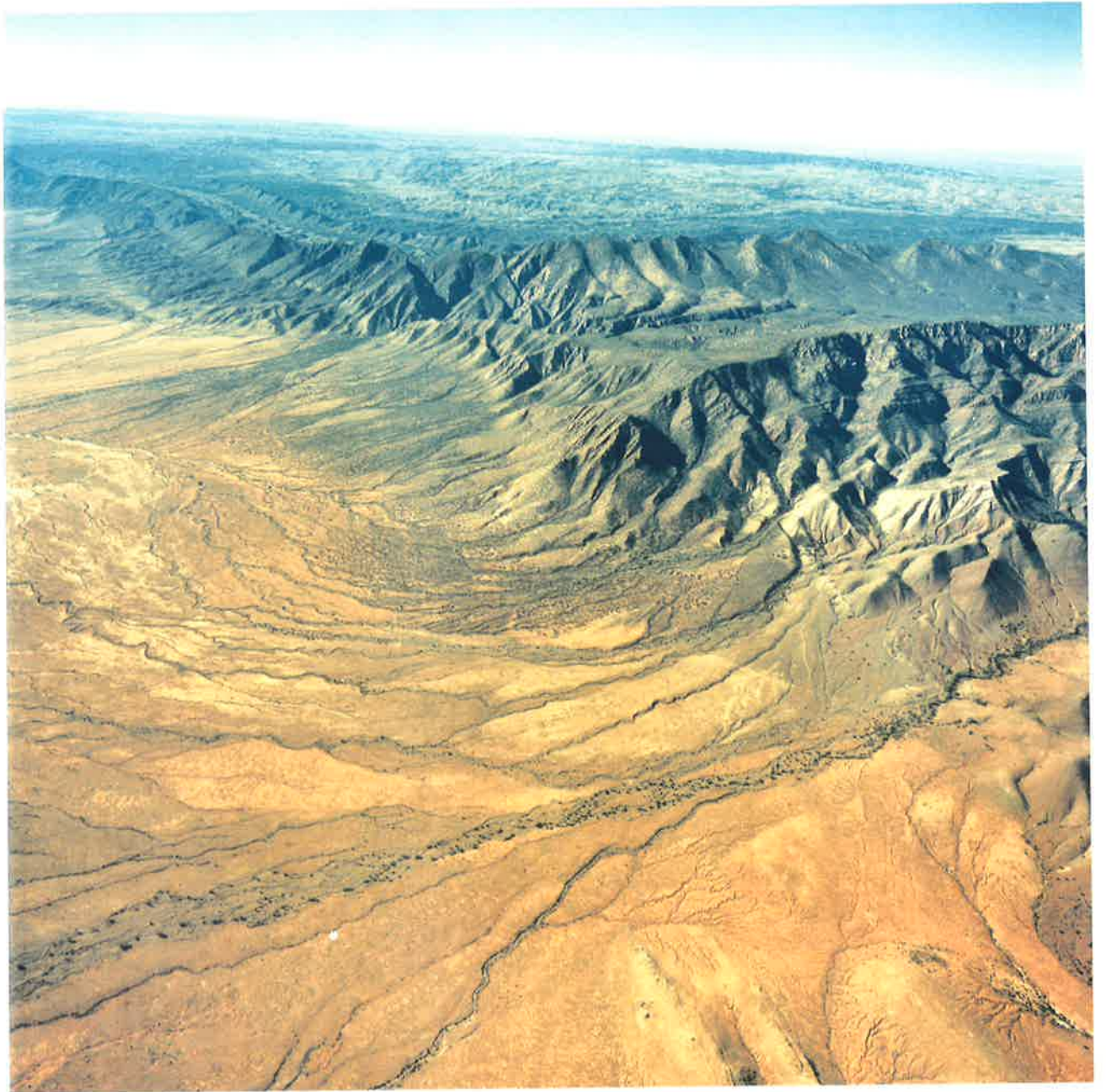
## Frontispiece

Oblique aerial view NNE over the ridge and valley topography of the Flinders Ranges. Aliena Washout (foreground) is a complex feature in the western piedmont of the upland, incorporating covered pediment (P), high pediment (hP), rock pediment (rP) and alluvial fan (AF).

(Aerial Photography, Survey 3117/064, Department of Environment and Natural Resources, South Australia).







## LIST OF TABLES

		following page
Table 1.1	Bores and wells logged in the study area.	8
Table 3.1	Drainage Basins and Pediments: Parachilna-Edeowie region.	37
Table 3.2	Summary of shallow seismic refraction survey results.	38
Table 3.3	Pediments of the Wyacca-Emeroo region.	47
Table 3.4	Drainage basins other than those related to major alluvial fans: Wyacca-Emeroo region.	47
Table 4.1	Major alluvial fans in the western piedmont of the Flinders Ranges.	52
Table 4.2	Spacing of streams emerging from the upland and depositing major alluvial fans in the western piedmont of the Flinders Ranges.	52
Table 4.3	Spacing of streams emerging from the Wyacca-Emeroo upland and depositing alluvial fans.	53
Table 4.4	Drainage Basins, Pediments and Alluvial Fans: Parachilna-Edeowie region.	56
Table 4.5	'Munsell Soil Colors' of bulk samples.	65
Table 4.6	Summary of X-Ray Diffraction analysis of bulk samples.	66
Table 4.7	Summary of X-Ray Diffraction analysis of clay fraction of samples.	67
Table 4.8	Drainage Basins of Wyacca-Emeroo region listed according to stream ordering methods (after Strahler, 1957; Shreve, 1966).	68
Table 4.9	Percentage slope measurements in Deep Creek drainage basin (after Strahler, 1952).	69

## LIST OF FIGURES

Frontispiece      Aliena Washout (DENR).

Photographs taken by author unless attributed to the Department of Environment and Natural Resources, South Australia (DENR), or to Dr C. R. Twidale (CRT)

- Figure 1.1      Location map.
- Figure 1.2      Tectonic geology map.
- Figure 1.3      Epicentres recorded 1883-1992, Lake Torrens region.
- Figure 1.4      Geologically logged bores, seismic survey lines and major faults:  
(a) Parachilna-Edeowie region (b) Wyacca-Emeroo region.
- Figure 1.5      Summit surface of Flinders Ranges.
- Figure 1.6      Minor faults: (a) & (b) Parachilna-Edeowie region  
(c) Wyacca-Emeroo region.
- Figure 1.7      Thrust fault, Wilkatana North Creek  
(a) general view (b) detail.
- Figure 1.8      Geological sections: (a) Parachilna-Edeowie region  
(b) Wyacca-Emeroo region (c) Location map.
- Figure 1.9      Borelogs of Cainozoic sediments, outer piedmont zone  
of Parachilna-Edeowie region.
- Figure 1.10      Streams incised in channel fill (a) Brachina and (b) Hookina creeks.
- Figure 1.11      Late Pleistocene high sea levels in South Australia related to  
(a) Australian record and (b) deep sea core information  
(Drexel & Preiss, 1995, p.228).
- Figure 2.1      Pediments (a) western Cape Fold Belt, South Africa (CRT) (b) Front  
Range, Colorado, U.S.A. (CRT) (c) Monument Valley, Arizona.
- Figure 2.2      Alluvial deposits onlap bedrock of upland, Death Valley, U.S.A.
- Figure 2.3      Piedmont angle due to concentration of moisture, weathering and erosion  
at the scarp foot in granitic gneiss (a) Namaqualand (CRT)  
(b) Namibia (CRT).
- Figure 2.4      Stream undercuts wall of valley (a) Gower Gulch, Death Valley (CRT)  
(b) pediment pass in Namaqualand (CRT)

- Figure 2.5 Granite nubbin rises abruptly from the surrounding pediment surface, Naraku, Queensland
- Figure 2.6 Covered pediments below Zabriskie Point, U.S.A. (CRT).
- Figure 2.7 Domed inselberg surrounded by pediment apron, Ucontitchie Hill, South Australia
- Figure 2.8 Tectonism and Badwater alluvial fan deposits, Death Valley, U.S.A.
- Figure 2.9 Variation in fanglomerates, Death Valley
- Figure 2.10 Alluvial fan of sieve deposits, Death Valley
- Figure 3.1 Morphology map: Parachilna-Edeowie region.
- Figure 3.2 Morphology map: Wyacca-Emeroo region.
- Figure 3.3 (a) & (b) Transverse profiles of inner piedmont zone: Parachilna-Edeowie region (c) Location map.
- Figure 3.4 Development of scarp foot valley and exaggeration of pediment fan form
- Figure 3.5 Scarp foot valley eroded by tributaries of Walkandi Creek.
- Figure 3.6 Piedmont angle coincident with lithological boundary (a) Hayward Pediment (b) inner piedmont zone north of Brachina Creek (c) piedmont angle advances downdip (after Twidale, 1972).
- Figure 3.7 Bevelled limestone ridge and pediment remnants near Bunyeroo Creek (a) ground level and (b) oblique aerial views.
- Figure 3.8 (a) Radial profiles of piedmont: Parachilna-Edeowie region (b) Location map.
- Figure 3.9 Bedrock-alluvial contact of pediment in bank of (a) Bunyeroo and (b) Ilina North creeks.
- Figure 3.10 Maps of main pediment surface associated with Hayward Creek (a) topography, inset location map: shallow seismic refraction survey (b) geology (c) morphology.
- Figure 3.11 Comparison of (a) pediment cover on main pediment, north of Brachina Creek (b) bedload, Brachina Creek (c) palaeodrainage line at Edeowie.
- Figure 3.12 Typical boulders of pediment cover (a) sandstone (b) quartzite and (c) typical pediment cover.
- Figure 3.13 Road cutting in Ralston 'Pediment', near Boulder, Colorado (CRT).

- Figure 3.14 Shallow seismic refraction survey team on Hayward Pediment.
- Figure 3.15 Examples of computer printout of shallow seismic refraction survey of Hayward Pediment.
- Figure 3.16 (a) Section drawn from results of shallow seismic refraction survey.  
(b) Diagram of presumed behaviour of water table.
- Figure 3.17 Map of Bundulla-Walkandi high pediment remnants.
- Figure 3.18 High pediment remnants stand above level of main pediment.
- Figure 3.19 Profiles of Bundulla-Walkandi high pediment area.
- Figure 3.20 Map of drainage basins excluding those related to major alluvial fans: Parachilna-Edeowie region.
- Figure 3.21 Dissection of high pediment surface.
- Figure 3.22 (a) Oblique aerial view of Bunyeroo 'high' pediment (b) buttressed by orthoquartzite (c) seen in detail.
- Figure 3.23 Map of orthoquartzite outcrops and the Bunyeroo 'high' pediment.
- Figure 3.24 Modern pediment eroded at the expense of the main pediment near Brachina Creek.
- Figure 3.25 Modern pediment adjacent to Bunyeroo Creek.
- Figure 3.26 Modern pediment associated with 'White Cliff Creek' (a) general view (b) White Cliff section (c) pediment surface detail, compared to (c) modern pediment at Rawnsley Bluff.
- Figure 3.27 Map of Edeowie riverine outwash plain and environs.
- Figure 3.28 Oblique aerial view of Edeowie riverine outwash plain (DENR).
- Figure 3.29 Topographical cross sections of Brachina Creek.
- Figure 3.30 Truncated flattened spurs south of Deep Creek (a) computer generated block diagram (b) view at ground level (c) field sketch.
- Figure 3.31 Pediments in piedmont of Wyacca Range (a) vertical air photograph (DENR) (b) view at ground level.
- Figure 3.32 Pediment remnants north of Depot Creek.
- Figure 3.33 Pediment surface protected by rampart of resistant strata (a) north of Thompson Creek (b) field sketch
- Figure 3.34 Pediment surface adjacent to Deep Creek gorge

- Figure 3.35 Pediment embayment associated with South Creek (a) field sketch  
(b) view of remnants of the pediment adjacent to the stream.
- Figure 3.36 Relationship of pediment and alluvial fan surfaces (a) north of Deep  
Creek and (b) south of South Creek.
- Figure 3.37 Map of drainage basins other than those associated with major alluvial  
fans: Wyacca-Emeroo region (a) Wyacca and Emeroo ranges  
(b) Central Section.
- Figure 4.1 Alluvial fans dominate the study area.
- Figure 4.2 Highest points of the Wyacca-Emeroo upland occur behind that sector of  
the piedmont in which major alluvial fans are deposited
- Figure 4.3 Drainage to Lake Torrens, Flinders Ranges.
- Figure 4.4 Vertical air photograph of Parachilna Alluvial Fan (DENR).
- Figure 4.5 (a) Axis and azimuth profiles: Parachilna-Edeowie region (b) Location  
of profiles indicated on accompanying map.
- Figure 4.6 Oblique aerial view of drainage texture domains on Parachilna Alluvial  
Fan
- Figure 4.7 Satellite imagery of Parachilna Alluvial Fan.
- Figure 4.8 Alluvial fan deposits of Brachina Creek in section (a) northern bank in  
midfan area (b) mid-channel bar.
- Figure 4.9 Brachina Creek divides into two braided streams, Brachina Creek and  
Brachina Overflow, which are entrenched in their alluvial fan deposits.
- Figure 4.10 Landform assemblage of the piedmont immediately north of Brachina  
Creek (a) vertical air photograph (DENR) (b) diagram of (a).
- Figure 4.11 Minor alluvial fan deposited by Ilina Creek North.
- Figure 4.12 Transverse profiles: piedmont between Thompson and Deep creeks,  
Wyacca-Emeroo region.
- Figure 4.13 Angular material contributed to upper parts of alluvial fans in  
(a) talus cone (b) rock screes.
- Figure 4.14 Minor debris flow in Wilkatana North Creek deposits.
- Figure 4.15 Fluvial deposits of Deep Creek.

- Figure 4.16 (a) Axis and azimuth profiles: Wyacca-Emeroo region (b) Location of profiles indicated on accompanying map.
- Figure 4.17 Decrease in size of boulders on alluvial fans, with distance from the upland, Wyacca-Emeroo region. Boulder and soil sample sites indicated on accompanying map.
- Figure 4.18 Surface morphology of Deep Creek Alluvial Fan (DENR).
- Figure 4.19 Intersection points (a) Thompson Creek (b) Deep Creek.
- Figure 4.20 Bar and pavement topography of Dry South Creek Alluvial Fan.
- Figure 4.21 Diagrammatic cross sections showing stratigraphic relationship of older and younger alluvial deposits, Wyacca-Emeroo region.
- Figure 4.22 Younger (brown) over older (yellowish-red) alluvial deposits in (a) Thompson Creek, and (b) Wilkatana North Creek.
- Figure 4.23 Examples of X-Ray Diffraction analyses of bulk sample, clay fraction and with ethylene glycol added, from (a) Depot Creek and (b) Dry South Creek alluvial fans.
- Figure 4.24 Presence of chlorite and kaolinite diagnostic of the presence of smectite.
- Figure 4.25 Drainage basins of the major alluvial fans: Wyacca-Emeroo region.
- Figure 4.26 Maps of Deep Creek catchment to exemplify (a) geology (b) slope (c) topography and (d) drainage network, typical of the streams which have deposited major alluvial fans in the Wyacca-Emeroo region.
- Figure 4.27 Sediment is readily available in the Deep Creek catchment, for example, (a) alluvial terrace (b) dammed by bedrock bars (c) talus cone.
- Figure 4.28 Rock screes on upland slopes south of Wilkatana North Creek.
- Figure 4.29 Minor alluvial fan south of South Creek.
- Figure 5.1 Catchments are critical to understanding the distribution of pediments and alluvial fans in the study area.
- Figure 5.2 Evolutionary sequence suggested for the development of pediments and alluvial fans.
- Figure 5.3 Pediment replaced by distal, lateral and headward growth of alluvial fan (a) in plan (b) in section (c) Parachilna-Edeowie region, and (d) Wyacca-Emeroo region.

- Figure 5.4 Vertical air photographs demonstrate little change in the braided channels of Brachina Creek between 1958 and 1992 (DENR).
- Figure 5.5 Morphology and geology of Aliena Washout and environs.
- Figure 5.6 (a) Rock pediment forms part of the upper slopes of Aliena Washout  
(b) fissile and brittle nature of bedrock surface
- Figure 5.7 Alluvial fan deposits of Aliena Washout exposed in the banks of Wobma Creek.
- Figure 5.8 Remnants of rock pediment associated with Pettana Creek, a tributary of Willochra Creek.
- Figure AI.1 Satellite imagery of alluvial fans and pediments in the vicinity of Parachilna Creek.
- Figure AI.2 Satellite imagery of alluvial fans and pediments near Wilkatana, Wyacca-Emeroo region.
- Figure AI.3 Generalised contours: Parachilna-Edeowie region
- Figure AI.4 Generalised contours: Wyacca-Emeroo region.
- Figure AI.5 (a) Numerous short streams incised in the upper slopes of the pediment, but (b) fewer streams dissect the lower slopes of the pediment.  
(c) Alluvial fan surfaces display a more uniform network of channels.
- Figure AI.6 Location map of drainage texture curve sampling strips: Parachilna-Edeowie region.
- Figure AI.7 Location map of drainage texture curve sampling strips: Wyacca-Emeroo region.
- Figure AI.8 Texture curves for pediments from the study area.
- Figure AI.9 Texture curves for alluvial fans from the study area.
- Figure AIV.1 Location map for synoptic weather stations and selected rain gauge stations.  
of the Flinders Ranges region.



## ABSTRACT

The Flinders Ranges is a fold belt involving Proterozoic and Early Palaeozoic strata and located in the arid-semiarid interior of South Australia. The margin of the upland is in places faulted but the hill-plain junction is most commonly determined by lithology. The western piedmont of the Ranges consists of pediments, mainly of the covered type, and alluvial fans. Their distribution varies regionally, for although the two forms commonly coexist, alluvial fans are prominent south of the Willochra outlet, and pediments to the north. Some pediments are clearly contemporary, being associated with present local baselevels, others are dissected, occur in flights, and are relic forms. Alluvial fans are consistently deposited in broad depressions eroded into and below the level of the pediments.

The Aliena Washout or Fan well exemplifies the relationships between pediments and alluvial fans. At its head the feature is a rock pediment cut in purple shale which is exposed at the surface. To either side run slightly incised streams which downslope have coalesced to form a covered pediment. Further downslope, as the detrital cover thickens, an alluvial fan extends some 5 kilometres from the scarp foot. The pediment area is flanked to north and south by remnants of a higher pediment cut in folded sediments but covered and protected by 1-2 metres of coarse detritus. Clearly the Aliena Alluvial Fan is younger than the covered pediments to either side. Laterally migrating streams are responsible for the rock pediment, covered pediment and alluvial fan.

In the study area pediments are invariably older than the alluvial fans. Pediments are in effect replaced by alluvial fans, not by burial, but by dissection and lateral substitution, until the fanhead lies within the mouth of the gorge at the upland margin. The landscape element described in this study as a 'riverine outwash plain' can be interpreted as either a contemporary covered pediment or the initial deposits of an alluvial fan, and is an important part of this explanation. Investigation of the catchments, with which the piedmont forms are genetically related, shows that the pediments are associated with small catchments dominated by resistant sediments, whereas those supplying alluvial fans are larger and

dominated by outcrops of argillite. From these temporal and spatial relationships it is suggested that pediments and alluvial fans are members of an evolutionary sequence which is, in some respects, peculiar to the structural basis of the region. Whether baselevel lowering is a necessary factor in the change from erosional to depositional predominance is not clear. Minor alluvial fans have been deposited with no change of baselevel. On the other hand, Late Pleistocene upfaulting of the Ranges, lowering of sea level and lowering of the level of Lake Torrens are all in evidence. Baselevel lowering certainly makes possible thick accumulations of fan conglomerates, but is considered a contributory, rather than an essential, condition.

Similar relationships between pediments and alluvial fans have been noted elsewhere, for example in the Italoie and Paralana regions of the eastern piedmont of the Flinders Ranges; in Nevada, near Ely and McGill; and in various parts of the American West and Southwest.

## DECLARATION

This work contains no material which has been accepted for the award of any other degree or diploma in any university or other tertiary institution and, to the best of my knowledge and belief, contains no material previously published or written by another person, except where due reference has been made in the text.

I give consent to this copy of my thesis, when deposited in the University Library, being available for loan and photocopying.

SIGNED

DATE: 23-02-96

## ACKNOWLEDGEMENTS

The research was facilitated and supported by an Australian Postgraduate Research Award in Geomorphology. The scholarship was provided by the Australian Research Council, through Dr C. R. Twidale, in Large Grant A39030964, entitled 'Contrasted Stream Behaviour in the Piedmont Zone of the Flinders Ranges of South Australia'. Additional support was obtained from University Research Grants administered by the Department of Geology and Geophysics, University of Adelaide.

I am indebted to my Supervisor, Dr C. R. Twidale, for my enduring interest in pediments and arid zone geomorphology and thank him for his friendship, which I value, and his supportive encouragement over some twenty five years.

Advice has been sought and freely given by academic and general members of the Staff of the Department of Geology and Geophysics, University of Adelaide. Dr V. A. Gostin and Dr G. E. Williams acted, with my Supervisor, as my Departmental Thesis Committee. Their long-standing personal interest in the study area provided an invaluable framework for any discussions. I enjoyed my introduction to shallow seismic refraction survey work under the leadership of Dr R. R. Hillis and his colleague, Dr M. Rutty, with assistance from Shane Squire, who wielded the hammer. This collaborative study between Geomorphology and Geophysics was equipped from the Earth Science Department, Flinders University of South Australia, by kind permission of Professor S. A. Greenhalgh. Mr J. Stanley guided my X-Ray Diffraction studies, Mr G. Trevelyan undertook lapidary work, and Mr J. Willoughby matched my enthusiasm for satellite imagery of pediments and alluvial fans.

Professor W. Stuart encouraged co-operation with members of the National Centre for Petroleum Geology and Geophysics, University of Adelaide. In particular, I acknowledge Dr N. M. Lemon for guiding my interest in remote sensing and Mr A. Mitchell for informative discussions of, and preliminary calculations for, a geophysical survey of the Parachilna area.

South Australian Department of Mines and Energy personnel were supportive, especially Dr R. A. Callen for discussion of the eastern piedmont of the Flinders Ranges and Dr W. V. Preiss for the Wyacca-Emeroo region, Mr R. E. Read (Hydrology) for providing bore and well location in the study area, Mr D. Cockshell (Geophysics) for interpreting data from the 'BRA' test line run by Mr B. E. Milton, and Mr D. Love (Geophysics) for seismic records 1883-1992.

Officers of the Meteorological Bureau, Mr P. Davill and Ms J. Stevens, assisted with records and discussion of weather patterns for the study area. Stream gaugings for the Flinders Ranges were kindly provided by Mr R. Leaney of the Engineering and Water Supply Department, South Australia. Vertical and oblique aerial photographs are reproduced with permission of the Department of Environment and Natural Resources, South Australia, and thanks are due Mr H. Liepe and Ms J. LeSueur of the DENR Research Information Group, for special project mapping (Figures 3.17 & 3.30a).

Several visitors have accompanied me into the study area. Professor E. Molina Ballesteros (University of Salamanca, Spain), Professor G. M. Garzon Heydt (Universidad de Complutense, Madrid), Professor J. R. Vidal Romani (Lab. Xeoloxico de Laxe, A Coruna, Spain), Professor S. G. Wells (Desert Research Institute, Reno, Nevada) and Dr J. R. Nott (University of California, Riverside) each brought to bear their particular approach to landscape interpretation, based in their experience of European and North American geomorphology. This was most interesting and prompted lively discussion. Professor Molina Ballesteros also assisted with thin section and X-Ray Diffraction analyses. Opportunities to travel with geomorphologists in North America, Spain and Singapore/Malaysia occurred during the period of this study. I am most appreciative of the several field days spent in the United States of America in the company of Emeritus Professor W. C. Bradley in Boulder, Colorado, and Professor W. H. Bull in Tucson, Arizona.

My thanks to Dr C. G. Harrington (Los Alamos National Laboratory, New Mexico), who carried out rock varnish analysis of several samples from the pediment cover, and to Dr D.

Fink (Australian Nuclear Science and Technology Organisation, Menai, N.S.W.) for encouraging discussion, in the field, and sampling of similar material for *in situ* cosmogenic isotope analysis.

Friendly and hospitable people live in the piedmont zone of the Flinders Ranges. In the study area several of the stations were regularly visited and the owners/managers were unfailingly helpful. I acknowledge, in particular, Mr & Mrs R. Nut (Edeowie), Mrs E. Fels & Mr D. Fels (Merna Mora), Mr & Mrs A. Smart (Wilkatana), Mr J. Brooks (formerly of Emeroo), Mr & Mrs J. Fitzgerald (Narcoona), Mr & Mrs K. Fitzgerald (Depot Creek), Mr M. Willick and colleagues of Aboriginal & Torres Strait Islander Commission, Port Augusta (Emeroo) and Mr & Mrs J. Nagel (Yadlamalka).

My constant field companion (and mother), Mrs N. W. Shepherd provided sustenance and support both in the field and on the home front. Dr E. M. Campbell (Department of Geology and Geophysics, University of Adelaide) has been both friend and colleague and Mrs A. Kavanagh walked the Deep Creek catchment with energy and enthusiasm. I enjoyed, as always, the support of my family and benefitted from their fields of expertise: my husband, Tony for computing skills and mathematical expression, and my sons, Andrew for unravelling the mysteries of Mac versus IBM systems and David for colouring all the small maps and diagrams.



## CHAPTER ONE

### THE WESTERN PIEDMONT OF THE FLINDERS RANGES, SOUTH AUSTRALIA

#### I. THE PROBLEM

The relationship between pediments and alluvial fans has long attracted the attention of geologists and geomorphologists (Blackwelder, 1931; Blissenbach, 1954; Tuan, 1962; Denny, 1965, 1967; Williams, 1970; Bull, 1977). Although the two forms are typical of the piedmont and are morphologically similar, pediments are by definition of erosional origin, whereas alluvial fans are depositional forms underlain by, and due to the accumulation of, considerable thicknesses of sedimentary deposits. The two forms coexist in the piedmont of the Flinders Ranges, in the arid to semi-arid interior of South Australia, which area thus affords the opportunity to study pediments and alluvial fans in identical geological, climatic and topographic contexts (Figure 1.1).

The Flinders Ranges is a fold belt involving Proterozoic and Early Palaeozoic strata, and characterised by ridge and valley topography. The margin of the upland is in places associated with faults, but the hill-plain junction is most commonly determined by lithological contrasts. The upland streams flow to the salinas known as lakes Torrens, Frome and Eyre (Figure 1.1). The piedmont plains consist largely of a variable mix of pediments, alluvial fans, stream channels and associated flood plains, with occasional structural features, e.g. strike ridges, standing above the level of the plains. They slope gently down from the scarp foot for some 5-20 kilometres, before merging with the flat depositional plains associated with the lower parts of the various 'lake' basins. Although these lake plains are essentially fluvial in origin, they are characterised by fields of relic Late Pleistocene dunes stabilised by vegetation.

This study is concerned with the pediments and alluvial fans of the western piedmont of the Flinders Ranges between latitudes 31°00'S and 32°30'S (Figure 1.1). North of the

Willochra Creek outlet, pediments and pediment remnants are well represented in the piedmont of the Heysen Range, though major alluvial fans are developed in association with the Parachilna and Brachina-Bunyerroo creeks. To the south of the outlet, however, the pediments fronting the Wyacca and Emeroo ranges are minor elements in a landform assemblage dominated by alluvial fans.

Several questions arise. Why are pediments better developed in one sector of the piedmont and alluvial fans in another? This is the primary problem addressed in the thesis, but various secondary problems flow from, and are an integral part of, the major theme. For example, when were the pediments and alluvial fans formed? Alluvial fans continue to be deposited, but is there evidence for contemporary development of pediments? Are the pediments and alluvial fans temporarily distinct or were they formed simultaneously? If the latter, have different fluvial processes been at work or are the same processes responsible for the two forms? If the same processes have been at work, why does erosion dominate in one tract, deposition in another? - which question essentially reiterates the main thrust of the investigation.

## II. PLAN OF THE THESIS

The remainder of this introductory chapter is concerned with the geological and tectonic setting of the western piedmont of the Flinders Ranges. In Chapter Two, alluvial fans and pediments are discussed in general terms in a review of the literature. In Chapters Three and Four, respectively, pediments and alluvial fans of the western piedmont of the Flinders Ranges are described, as are the processes responsible for their development. The relationships and genesis of pediments and alluvial fans in the study area are discussed in Chapter Five, and some consideration is given to the implications of this study for the coexistence of the two landforms in other piedmont zones.



### III. STRUCTURAL FRAMEWORK OF THE FLINDERS RANGES AND THE TORRENS PLAIN

The structure of the Flinders Ranges and adjacent sedimentary basins provides the context (Figure 1.2) within which the landform assemblages of the Flinders Ranges, and in particular of the western piedmont of that upland, have evolved (Campana, 1958; Thomson, 1966; Stewart, 1972; Rutland, 1973; Preiss, 1987). The Torrens Hinge Zone (Thomson, 1970; Murrell, 1977), located to the west of the Ranges, remains one of pronounced seismic activity (Doyle *et al.*, 1968; Sutton & White, 1968; Cleary & Simpson, 1971; Stewart *et al.*, 1973; Greenhalgh & Denham, 1986; McCue, 1990; see also Figure 1.3). That there have been Cainozoic tectonic movements is especially significant, for changes in the relative elevation of upland and plain may have affected stream behaviour within the region. The chronology of sedimentation in the Pirie-Torrens Basin (Johns, 1968a & b) is also relevant, for it allows maximum ages to be deduced for the land surfaces of the region.

#### A. FLINDERS RANGES AND ENVIRONS

Rocks of the Adelaide Geosyncline, which term is used here in a descriptive rather than generic sense (Preiss, 1987), are exposed in the Mount Lofty and Flinders ranges in South Australia. The ranges run meridionally through southern Australia (Cleary & Simpson, 1971; McElhinney, 1973; Denham *et al.*, 1975). They were formed at an ancient convergent plate boundary, and are presently situated mid-continent within the Indian-Australian Plate. The structure extends northwestward from the Flinders Ranges via the Willouran, Peake and Davenport (Denison) Ranges to the Musgrave Block and into Western Australia (Wopfner, 1972; Preiss, 1987; Drexel *et al.*, 1993). The surface of the crystalline basement, which crops out in the Mount Painter and Mount Babbage areas in the Flinders Ranges and in several small inliers in the Mount Lofty Ranges (Preiss, 1987; Drexel *et al.*, 1993), is relatively undeformed (Gerdes, 1982). The Mount Lofty and Flinders ranges together form a reactivated structure developed in this high density basement (Thomson, 1969a & b; Wellman & Greenhalgh, 1988), which was bounded by

the Gawler Craton in the west and the Curnamona Cratonic Nucleus in the northeast (Figure 1.2).

A thin cover of Proterozoic and Cambrian sediments was deposited on the eastern margin of the Gawler Craton, on the area known as the Stuart Shelf. It remains virtually undisturbed and has been dissected to give plateau, mesa and butte forms in the Arcoona Plateau (Twidale *et al.*, 1970; Twidale *et al.*, 1986). The sediments are thin in the south, in the Port Augusta-Iron Knob area, but thicken northwards, where they form a broad upwarp, the eastern limb of which is faulted. Further north, the whole structure is downthrown along a NNE trending fault passing through Andamooka H.S. (Anderson, 1979; Dalgarno, 1982). These shelf sediments can be traced eastwards and are correlated with the folded sequences of the Flinders Ranges.

Four major cycles of deposition are evidenced during the Proterozoic in the Adelaide Geosyncline. Each is characterised by distinctive sedimentary sequences and tectonic style and is separated by an unconformity (Thomson *et al.*, 1964; Preiss, 1987; Drexel *et al.*, 1993). Quartzite and sandstone are common, interbedded with mudstone, siltstone, limestone, some basal conglomerate and glaciogene sediments. Deposition took place in shallow seas and under paralic conditions, which continued through the Cambrian. It was accompanied by minor folding, faulting, uplift and some erosion (Forbes, 1972; Moore, 1979). Subsequently, Cambrian sediments derived mostly from the Willyama Block accumulated in the intracratonic Arrowie Basin (Milton *et al.*, 1973). Sedimentation ceased when the Cambro-Ordovician Delamerian Orogeny created the ancestral Mount Lofty-Flinders Ranges.

At first, the sediments were affected by east-west compression, which produced the broad domes and open synclines of the central Flinders Ranges. These stand in marked contrast with the structures to north and south of this zone. The North Flinders and Nackara arcs are belts of arcuate, upright, tighter folds with slaty cleavage and greenschist metamorphism, formed when the deposits were subjected to a later stage of north-south compression (Preiss, 1987; Drexel *et al.*, 1993). Three major linear gravity corridors or

lineaments (O'Driscoll, 1983, 1986), associated with significant ore deposits, impose directional controls on these structures (Figure 1.2).

*Décollement* allowed the simple folds of the central Flinders Ranges to be developed independently of the crystalline basement. The regularity of these largely simple folds was disturbed by the injection of plastic argillites, some with pseudomorphs of halite. The Callanna Beds, the oldest Adelaidean sediments, are commonly involved and are mapped as diapirs throughout the Flinders Ranges (Webb, 1961; Webb & von der Borch, 1962; Dalgarno & Johnson, 1968; Thomson, 1969b; Mount, 1975; Thomson *et al.*, 1976; Lemon, 1985, 1988a, 1996). They occur in the cores of anticlines, e.g. the Oraparinna and Blinman structures, and along fracture zones, as in Thompson Gap and the western scarp of Emeroo Range (Figure 1.4).

After the Delamerian Orogeny, the remainder of the Palaeozoic and much of the Mesozoic eras were tectonically quiescent. Triassic sediments preserved in basins in the Copley and Leigh Creek area and around the northern margins of the Willochra Plain must have originated in the erosion of the Ranges, and their character suggests derivation from a landscape of low relief; but no Triassic land surface has been identified. Jurassic epeirogenic movements formed the Eromanga Basin to the north (Figure 1.2). Shallow Cretaceous (Neocomian) seas encroached on the Flinders Ranges and adjacent lowlands from the north (Frakes *et al.*, 1987), and west from the Lake Frome Embayment (Callen, 1973). Aptian littoral sediments cap Mount Babbage (Woodard, 1955; Alley & Lemon, 1988; Lemon, 1988b, 1996) and are present in basins marginal to the upland (e.g. Parker, 1987; Swift, 1987). The sediments probably mark the southerly limit in the Flinders Ranges of the Early Cretaceous seas, which retreated in Cenomanian time. The Early Cretaceous sediments which must have once covered the area around Mount Babbage have been eroded from the upland, exhuming the sub-Cretaceous, possibly Late Jurassic, surface, over which the Cretaceous seas advanced (Woodard, 1955; Campana, 1958; Twidale, 1966a, 1969, 1980; Coats & Blissett, 1971; Twidale & Campbell, 1988; Twidale & Bourne, 1996). To the south, a palaeosurface, possibly eroded by rivers graded to the Cretaceous shoreline, occurs as a pronounced summit bevel, above which stand some

resistant knolls and ridges. It is prominent throughout northern and central Flinders Ranges (Figure 1.5) and preserved in bevelled ridges in the south, adjacent to the Willochra Basin (Twidale, 1980; Twidale & Campbell, 1988), where its Cretaceous or older age is confirmed by Eocene lacustrine sediments which occur in valley floors, well below the summit levels.

This complex surface of Late Jurassic-Cretaceous age was disrupted and dissected when renewed uplift of the Flinders Ranges began after the Early Cretaceous (Wellman & Greenhalgh, 1988) and certainly by the Eocene (Veevers, 1984). Indeed, by the Middle Eocene the present topographic framework was already established, for a lake occupied the northern Willochra Basin and tongued up valleys such as those of the present Kanyaka and Mount Arden creeks (see Twidale, 1966a, 1991; Twidale & Bourne, 1996). As the Mount Lofty-Flinders ranges were uplifted, marginal sedimentary basins, including the Pirie-Torrens Basin, were established (Figure 1.2). Intermittent earth movements continued along old established fault lines at least during the Eocene to Miocene (Webb, 1958; Stewart, 1972; Callen & Tedford, 1976). At the western margin of the Flinders Ranges and immediately north of the study area silcrete is associated with movements along the Ediacara Fault: 'pre-upper Eocene' silcrete capping a Mesozoic landscape was carried down on fault blocks to either side of the Ediacara Range (Binks, 1972). At the northeastern margins of the Flinders Ranges silcrete caps mesas and cuestas in Miocene Namba Formation (Callen & Tedford, 1976), which has evidently been disrupted by tectonism. Callen (1983) identified a Late Tertiary opaline, chalcedonic silcrete, in addition to the microquartz silcrete known to be developed on Eocene Eyre Formation (Forbes, 1966; Coats, 1973; Wopfner *et al.*, 1974), and observed that both silcreted were affected by faulting.

## B. PIRIE-TORRENS BASIN

The Pirie-Torrens Basin underlies the Torrens Plain and Port Augusta Corridor, which encompass that part of the western piedmont of the Flinders Ranges which is the study area (Figure 1.2). The Basin occupies part of the Torrens Hinge Zone which is a fault angle

depression, or half-graben, consisting of a series of fault blocks, which have gradually subsided some 600 metres. Evidence from both flanks and the regional geophysical signatures suggest that the fault blocks of the Pirie-Torrens Basin have been, and continue to be, overridden and depressed (Lemon, 1996).

The Basin is bounded on the west by the Torrens Lineament (Figure 1.2), which finds surface expression in the linear western coastline of northern Spencer Gulf and the western shore of Lake Torrens (Johns, 1968a & b; Thomson, 1973; Murrell, 1977; O'Driscoll, 1981, 1983). A series of fractures parallel to, and offset from, the Torrens Lineament, due to the wrenching and tearing movements which accompanied the foundering of Spencer Gulf, have been described from northeastern Eyre Peninsula (Miles, 1952). The evidence is largely morphological, in the form of low linear scarps, but an exposure of the Murninnie Fault in a gently inclined mine shaft indicates reverse faulting (Dunham, 1992).

The eastern margin of the Pirie-Torrens Basin is not a single continuous fracture, but rather a zone of fractures and warps (Figures 1.2 & 1.4). North of Parachilna a series of meridional faults occurs at the western margins of Mount Deception, Red and Ediacara ranges (Kendall, 1968; Leeson, 1970; Binks, 1972) and the Northwest Fault was described as a westward thrust of Flinders Ranges sediments (Campana, 1958). South of Mount Burns the upland is defined by the Arden Fault (Dalgarno *et al.*, 1968). In the Parachilna-Edeowie region, however, the upland margin appears to be a lithological boundary (Dalgarno & Johnson, 1966; Forbes, 1972), although a number of short, *en echelon* faults trending WNW and ESE indicate possible thrusting and rotational movements (Anonymous, 1974; Anonymous, 1982; Figure 1.6a & b). Field exposures, as well as stratigraphic evidence, show that the margin of the Wyacca-Emeroo ranges, though largely defined by the massive Rhynie Sandstone/Emeroo Quartzite, is also associated with thrust faults as, for instance, at Wilkatana North Creek outlet (Figure 1.7), Depot Creek and in the Emeroo Range front (Williams, 1973; Preiss & Faulkner, 1984; Sukanta, 1987; see Figure 1.6c).

## 1. Tertiary Sub-basins

The western piedmont and alluvial plains of the Flinders Ranges are underlain by Tertiary sediments preserved in structural sub-basins of the Pirie-Torrens Basin. North of Parachilna the Beltana Sub-basin occurs between the Ediacara Range and the Flinders Ranges proper, its floor dipping gently to the east (Pegum, 1957; Kendall, 1968; Leeson, 1970; Binks, 1972). Seismic survey and borelog evidence (Figure 1.4, Table 1.1) show that it extends south of Parachilna as a graben or syncline fronting the Flinders Ranges (Figure 1.8a). It is bounded on the west by a basement high or fault located approximately on the line of the Parachilna-Brachina road and linking the Ediacara and Arden faults (Kendall, 1968; Anonymous, 1982; Cockshell, 1983). The known deepest part of the basin, i.e. 440+ metres, is located in Edeowie No.1 Stratigraphic Bore. From this site Cainozoic sediments thin to north and south. Fifty to sixty metres of Quaternary fluvial sediments overlies one hundred and fifty metres of Tertiary sediments, tentatively correlated with the lacustrine Billa Kalina Clay Member of the Miocene Mirikata Formation (Jessup & Norris, 1971; Ambrose & Flint, 1981) which overlie Eocene Eyre Formation, including Late Eocene lignite seams and lignitic fragments low in the sequence (Cockshell, 1983). Similar Eocene sediments were intersected elsewhere in the sub-basin, but at shallower depths. This was confirmed by the correlation of overlying units, particularly with the calcareous Miocene Namba Formation equivalents (Callen & Tedford, 1976; Anonymous, 1982; see Figure 1.9).

Another Early Tertiary sub-basin occurs in the Wilkatana area south of Lake Torrens, where Cainozoic sediments up to 187 metres thick include Early Tertiary (?Eocene) lignites (Figure 1.4, Table 1.1). The sediments lie within a broad synclinal fold pitching gently to the NNE (Figure 1.8b), and are thicker nearest to the range front (Coxhead, 1982; Preiss & Faulkner, 1984). Near Yadlamalka, 93 metres of Cainozoic sediments wedge out against a basement high trending east-west, which has been compared to the ridge of Proterozoic rocks outcropping south of Port Augusta in Mount Grainger and associated low hills (Coxhead, 1982).

Table 1.1 Bores and wells logged in the study area.

BORE LOCATION (distance from scarp in km)	DEPTH OF BORE (m)	CAINOZOIC THICKNESS (m)	THICKNESS		TERTIARY LIGNITE (Yes (No)	B/R C or P	REMARKS & REFERENCE
			4Y (m)	3Y (m)			
<b>PARACHILNA ALLUVIAL FAN</b>							
CO-1(3.5) N fan edge	150	150+	-	-	N	-	Anon., 1982
CO-2(5) upper- mid fan	148	148+	-	-	N	-	Anon., 1982
98(8) lower a/f	65	65+	-	-	N	-	clay/gravel/sand SADME Hydrol dept
50(10) lower a/f	68	68+	-	-	N	-	cl/gr/sand+silcrete Sibenaler, 1979
91(12) lower a/f	100	100+	-	-	N	-	cl/gr/sand SADME Hydrol.
39(15) lower a/f	56	56+	-	-	N	-	cl/gr/sand SADME Hydrol.'
47(18.5) ditto	36	36+	-	-	N	-	cl/gr/sand SADME Hydrol.
43(21) dunefield Santos Motpena 1	214	168	52	(116)	N	?C	( )?wth'd B/R Vakil 1983; Kendall, 1968
97(37.5) lunette Old Motpena No.1	564	314 (291)	98	216 (193)		C	( ) wth'd B/R depth Vakil, 1983
3A(41) bed(east) Lake Torrens SB	270	270+	80	191+	Y	-	low/middle Eocene Johns, 1968
<b>BRACHINA ALLUVIAL FAN</b>							
Edeowie No.1 SB (10)	981	444 (305)	51 51	393 (254)	Y	C	( ) wth'd B/R depth 3Y:Mio/Eo Eyre Fn. Cockshell, 1983
62(10) lower a/f	55	55+	-	-	N	-	cl/gr/sand SADME Hydrol.
66(11) lower a/f	110	86	-	-	N	?	cl/gr/sand/tr.lime SADME Hydrol.
65(11) lower a/f	63	63+	-	-	N	-	cl/gr/sand SADME Hydrol.
CO-3(12.5) ditto	148	148+	-	-	N	-	Anon., 1982
<b>BUNYEROO ALLUVIAL FAN</b>							
CO-6(6.5) lower a/f	150	150+	-	-	N	-	Anon., 1982
CO-4(8)	150	150+	-	-	N	-	Anon., 1982
68:(8.5) lower a/f	64	64+	-	-	N	-	cl/gr/sand SADME Hydrol.
69(10) lower a/f	162	162+	-	-	N	-	cl/gr/sand Sibenaler, 1979
CO-5(11) lower a/f	150	150+	-	-	N	-	Anon., 1982
88(12.5) lower a/f	51	51+	-	-	N	-	cl/gr/sand SADME Hydrol.
21(23) dunefield	41	41+	-	-	N	-	
CO-7(5) interfan Edeowie HS	150	150+	-	-	Y	-	Anon., 1982

BORE LOCATION (distance from scarp in km)	DEPTH OF BORE (m)	CAINOZOIC THICKNESS (m)	THICKNESS		TERTIARY LIGNITE (Y)es (N)o	B/R C or P	REMARKS & REFERENCE
			4Y (m)	3Y (m)			
<b>HOOKINA ALLUVIAL FAN</b>							
240(10) dune- field	55	55+	-	-	N	-	cl/gr/sand SADME Hydrol.
23(10.5) ditto	37	37+	-	-	N	-	cl/gr/sand SADME Hydrol.
237(11) ditto	43	43+	-	-	N	-	cl/gr/sand SADME Hydrol.
269(13) ditto	44	44+	-	-	N	-	cl/gr/sand SADME Hydrol.
272(16.5) ditto	34	34+	-	-	N	-	cl/gr/sand SADME Hydrol.
270(18) ditto	64	64+	-	-	N	-	cl/sand SADME Hydrol.
8(20) ditto	63	63+	-	-	N	-	cl/gr/sand SADME Hydrol.
271(23) ditto	54	54+	-	-	N	-	cl/gr/sand SADME Hydrol.
27(21) alluvial plain	18	18+	-	-	N	-	clays SADME Hydrol.
33(26) Yadlamalka No.1	656	93			Y	P	Coxhead, 1982
28(27) alluvial plain	21	21+	-	-	N	-	clays SADME Hydrol.
<b>SOUTH OF LAKE TORRENS</b>							
TR1A(17)	198	98	98	-	N	P	Johns, 1968
TR2(16)	209	207	91	116	Y	C	Johns, 1968
<b>PORT AUGUSTA CORRIDOR: dunes &amp; salinas</b>							
8(6) Wilk.17	64	56	-	-	N	C	Santos 1955/58
15(8) Wilk.15	177	134	-	(85)	Y	P	lignite 375m Santos 1955/58
65(9) Wilk.12	334	187	-	(101)	Y	C	Santos 1955/58
16(9.5)Wilk.16	281	131	-	(103)	Y	C	Santos 1955/58
14(11) Wilk.11	358	135	-	(99)	Y	C	Santos 1955/58
37(11) Wilk.1 /Yarrah No.1	670	141	-	(96)	Y	C	Santos 1955/58 Milton et al,1973
18(10) Wilk.19	54	54+	-	-	N	-	sands/clays SADME
178(11) Wilk.3	44	44+	-	-	N	-	gr/clays SADME
7(11.5) Wilk.2	332	127	-	(100)	Y	C	Santos 1955/58
12(12.5)Wilk.10	14	14+	-	-	N	-	Santos 1955/58
13(12.5)Wilk.10A	81	81+	-	(42)	Y	-	Santos 1955/58
19(15.5)	65	65+	-	-	N	-	cl/gr/sand SADME
9(16) Wilk. 9	136	105	-	-	N	P	Santos 1955/58
<b>WILKATANA NORTH ALLUVIAL FAN</b>							
195(3)	88	88+	-	-	N	-	gr/clays SADME
186(3) Wilk'a HS	64	64+	-	-	N	-	cl/gr/sand SADME
<b>DEPOT ALLUVIAL FAN</b>							
188(0) Depot Creek SB	874	8	-	-	-	P	Preiss & Faulkner, 1984
49(5.5)	61	53	-	-	N	-	



**Key: Table 1.1.**

**CAINOZOIC THICKNESS:**

number+ = unconfirmed Cainozoic thickness  
(number) = probable weathered bedrock between  
depth (in metres) within brackets and  
without.  
4Y = Quaternary sediments  
3Y = Tertiary sediments.

**B/R**

= BEDROCK  
C = Cambrian  
P = Proterozoic

## 2. Lake Torrens

Lake Torrens is a salina, some 5 900 square kilometres in extent. It is the focus of drainage of a considerable catchment, including the western Flinders Ranges north of the Willochra Creek outlet. Streams flowing westward from the Flinders Ranges usually dissipate their waters in swamps and on alluvial flats within the dunefield east of the Lake, but deltaic deposits on the lake bed indicate that flood waters from the larger rivers, such as the Brachina, Hookina and Willochra creeks, occasionally reach the shore, and spread on to the lake bed. The Lake surface stands about 35 metres above present sea level, but slopes gently down from east to west, 1.5 metres in 37 kilometres (Schmid, 1985).

Lake Torrens is located over the deepest part of the fault block adjacent to the Torrens Lineament (Risely, 1965; Johns, 1968a; Vakil, 1983; Schmid, 1985). More than 300 metres of continental lacustrine sediments have accumulated since the Eocene beneath Lake Torrens. Carbonaceous mudstone, sand and siltstone, of Eocene age (Johns, 1968a), are overlain by possible Miocene dolomite-mudstones, the appearance of which Johns (1968b) likened to the Etadunna Dolomite of Lake Eyre (Johns & Ludbrook, 1963). The dolomitic sequence is, in turn, overlain by Quaternary siltstone, clay, gypsum, sand and mud (Johns *et al.*, 1964; Johns, 1968a; Stratigraphic Bore 3A in Figure 1.4, Table 1.1).

The occurrence of evaporites -?Miocene dolomite and Quaternary gypsite - within the lacustrine sequence (Figure 1.4, Table 1.1) suggests that the basin was a closed drainage system throughout the Tertiary; there was no surface drainage from the Lake to the sea. (Nor is there any evidence that the sea ever flowed into the lake basin.) Waters may escape subsurface via a gravity trough, coincident with a zone of minor block faulting extending south from Lake Torrens (Pegum, 1957; Risely, 1967; Johns, 1968a; Finlayson, 1981). However, the occurrence of impermeable clay layers throughout the lake fill argues against free vertical movement of groundwaters from the Basin via this channel (Johns, 1968a; Schmid, 1985). In latest Pleistocene-Holocene times surface waters may have drained to the sea via the line of salinas and clay pans in the Port Augusta Corridor, between the southern end of Lake Torrens and the head of Spencer Gulf.

The Lake Torrens basin and its stratigraphy are important for the present study in two respects. First, the stratigraphic record preserved in the lake sediments allows a lower limit to be placed on the age of the piedmont landform assemblage discussed in this thesis. Second, Lake Torrens was the baselevel for many of the rivers draining from the Flinders Ranges during the Cainozoic.

(a) Age of the piedmont landform assemblages

During the Tertiary the Lake was more extensive than it now is. Lignitic sediments similar to the Eocene carbonaceous beds located near the base of the basin sequence beneath the Lake occur in the Tertiary sub-basins east of Lake Torrens and in the Wilkatana area (Figure 1.4; Table 1.1), and from near Port Augusta (Hullett, 1882; Firman, 1965). Upper Eocene carbonaceous clays and lignites also occur on the block downthrown 210 metres to the west of the Ediacara Fault (Leeson, 1970; Binks, 1972 - see Figure 1.4). Thus there are suggestions that Eocene strata underlie, or formerly underlay, substantial areas of the Torrens Plain east of the Lake, and thus that the piedmont features under review at least postdate the earliest Tertiary.

Putative Miocene lacustrine muds and silts are deposited unconformably on the Eocene beds in several sub-basins in the eastern Pirie-Torrens Basin. The ?Miocene age is based on tentative correlations, or lithological comparisons, rather than firm palaeontological evidence (e.g. Johns, 1968b; Anonymous, 1982; Cockshell, 1983). All pediments of the study area stand above these Miocene basin sediments and, therefore, are Miocene or postdate the Miocene in age.

Several pediment surfaces at the margins of the Pirie-Torrens Basin carry a cover of coarse detritus including crystalline silcrete and orthoquartzite. Such crystalline silcrete is probably of Miocene or older age (Hutton *et al.*, 1978; Callen, 1983) and is certainly older than the opaline silcrete found in the Lake Eyre Basin (Wopfner & Twidale, 1967). Although petrologically different, both silcrete and orthoquartzite are due to silicification and are viewed as representing the same geomorphological event.

During the Quaternary some 50-100 metres of fluvial sediments were deposited as alluvial fans extending from the western margins of upland and pediment and a similar thickness of Quaternary lacustrine sediments was deposited in Lake Torrens. In the Wyacca-Emeroo region alluvial fan deposits within 15 metres of the surface have been dated as Late Pleistocene (Williams, 1973), but at Parachilna and Brachina the alluvial fan sequences overlie the Miocene sequence.

Thus, the pediments and alluvial fans of the western piedmont zone of the Flinders Ranges post date the Eocene and probably the Miocene. No more precise dating is possible on the available stratigraphic evidence.

(b) Regional baselevel

Apart from the orthoquartzite, which occurs at the outer margin of the pediment apron near Bunyeroo Creek, and which could be interpreted as silica mobilised near the shores of a Tertiary lake (*cf.* Öpik, 1961; Ambrose & Flint, 1981), no morphological evidence of older, higher shorelines of Lake Torrens has been located in the study area. On the other hand, much of the Torrens Plain is underlain by lacustrine sediments suggesting that the Lake was more extensive during the Tertiary than it now is. Alluvial fills deposited in the gorges of major streams of the western piedmont of the Flinders Ranges, such as the Parachilna, Brachina and Hookina creeks, have been incised by up to 10 metres (Figure 1.10). Whether the resultant terraces are related to former higher lake levels, catastrophic floods or tectonic disturbance is not clear. A similar situation obtains in the Beda valley, in the southern Arcoona Plateau, which drains to the southwestern extremity of Lake Torrens (Figure 1.1). There, silcreted valley floors are now dissected by some 6-7 metres, either as a result of the lowering of the level of Lake Torrens (Twidale *et al.*, 1970), or, as the region lies astride a tectonically active hinge zone, as a result of movements associated with the Torrens Lineament. That streams on both western and eastern shores, display similar terrace sequences, suggests that baselevel change may be responsible.

### C. DEVELOPMENT OF SPENCER GULF

In the southern part of the study area, south of the Willochra Creek outlet, streams from the Flinders Ranges drain to the sea in the head of Spencer Gulf via the Port Augusta Corridor (Figure 1.1). The development of Spencer Gulf and any evidence of late Cainozoic changes of sea level in the Gulf are thus germane to any consideration of stream behaviour and landform assemblages.

Spencer Gulf occupies a downfaulted block, the subsidence of which allowed access to ocean waters, initially during the Eocene (Glaessner & Wade, 1958). The Gulfs extended gradually northwards so that seas occupied the northern part of Spencer Gulf in the Miocene (Lindsay, 1970). Fault scarps related to the foundering of northern Spencer Gulf suffered further dislocation during the Pliocene (Miles, 1952; Horwitz & Daily, 1958; Lindsay 1970; Dunham, 1992) and the region continues to be seismically active.

Eustatic changes in sea level were related to the Pleistocene period of waxing and waning of ice sheets and glaciers. Those which affected the coastline of South Australia during the last 150 Ka are shown in Figure 1.11. Before the Holocene transgression the sea entered Spencer Gulf twice in the Late Pleistocene; a degraded sea cliff occurs about 3 metres above present sea level on both sides of Spencer Gulf (Gostin *et al.*, 1981).

At the start of the Holocene (ca 10 000 years B.P.) sea level was approximately 25 metres below modern sea level. It rose to its present position some time prior to 6 000 years B.P. (Hopley & Thom, 1983). It has been virtually static (within 1 metre of present sea level) for the last 6 000-7 000 years, yet there is evidence of an apparent fall in Holocene sea level of some 3-5 metres around the head of the Gulf over the last 6 000 years (Crawford, 1963; Firman, 1965; Hails & Gostin, 1978; Burne, 1982; Hails *et al.*, 1983). Some suggest that hydroisostasy (Hopley & Thom, 1983; Nakada & Lambeck, 1989; Drexel & Preiss, 1995) is responsible, in part, for the height difference and others cite tectonic movements (Hails *et al.*, 1983). However, the consistent height above sea level of stranded shingle beaches, beach ridges and sea grass deposits argues for a higher sea level.

Moreover, seas are known to stand higher towards the heads of the gulfs because of the configuration of the coast. For example, present seas in northern Spencer Gulf regularly wash over palaeo levels, for the tidal range is in excess of 4 metres (Schluter *et al.*, 1995).

#### IV. CONCLUSION

The structural framework of the Flinders Ranges and environs is of considerable antiquity. Intermittent tectonism throughout the Cainozoic has caused recurrent uplifts of the Ranges. These, plus changes in local baselevel, have caused the streams draining the upland repeatedly to incise their beds. In addition, the effects of human occupation of the area, which conceivably spans the time period under consideration, cannot be overlooked. Such is the setting for the development of the landform assemblages of the western piedmont of the Flinders Ranges.

## CHAPTER TWO

### PEDIMENTS AND ALLUVIAL FANS: LITERATURE REVIEW AND CRITIQUE

#### I. INTRODUCTION

Both erosional and depositional landforms of fluvial derivation coexist within the piedmont of the Flinders Ranges. They may, therefore, be genetically related, and it is salutary to note that Grove Karl Gilbert, to whom is attributed the first geological application of the term 'pediment', used it to describe the surface of what today would be called an 'alluvial fan' (Gilbert, 1882, p.183). Thus, the two forms were confused from the first, and for good reason, for pediments and alluvial fans are morphologically similar. Both are characteristically triangular in plan shape, and slope gently down, and extend laterally away, from the point where the associated streams debouch from upland to plain. Both merge laterally with others of their kind to produce aprons fronting the uplands. Yet one is intrinsically erosional, the other depositional.

#### II. PEDIMENTS

##### A. GENERAL STATEMENT

Gilbert was responsible for the first cogent description of the planation of a bedrock surface by lateral corrasion, but, because the resultant surface survived as dissected remnants, he ambiguously referred to them as 'hills of planation' (Gilbert, 1877, pp.130-131). Smooth, cut bedrock surfaces were later designated 'pediments' by McGee (1897, p.92), who is generally credited with the first use of the term in the sense in which it is now applied (see for example Tator, 1952a, 1953).

The Shorter Oxford English Dictionary lists two derivations for the word 'pediment', viz. an architectural term for the triangular part, resembling a low gable, crowning the front of a

building in the Grecian, and later in Roman and Renaissance, styles; and the Latin *pes*, or foot, used for base or foundation (cf. Tuan, 1959). Such allusions find expression in descriptions of the landscape, for example:

*"Only in a distant view is it possible to realize that the surrounding plain rises gradually on all sides toward the mountains, which stand like jagged ornaments on the ridge-pole of a low-gabled roof."* (Bryan, 1922, p.38).

The literature concerned with the pediment landform has been reviewed by Tator (1952a, 1953), Tuan (1959), Hadley (1967), Cooke and Warren (1973), Whitaker (1973, 1975) and Twidale (1978, 1981). Pediments have been referred to as rock floors, rock benches, rock-planed surfaces, rock-cut surfaces, rock fans, rock plains, and conoplains. They are especially well developed in granitic terrains (Warnke, 1969; Cooke, 1970; Akagi, 1972; Mensching, 1978; Twidale, 1978, 1982a, 1983a), but they are also eroded in other igneous and metamorphic rocks, in sedimentary strata, and even in alluvium (Blackwelder, 1931; Gilluly, 1937; Howard, 1942; Balchin & Pye, 1955; Tuan, 1962; Denny, 1965; Mensching, 1970; Kar, 1984). Pediments eroded in alluvium were called peripediments (Howard, 1942), but the same term is used of buried pediments (Balchin & Pye, 1955). In some instances, and particularly in granitic terrains, pediments are eroded in the same rock type as the backing uplands, but in fold mountain belts, different lithologies commonly underlie the pediments on the one hand, and backing uplands on the other.

Pediments occur in various topographic settings regardless of altitude or distance from sea: near the coasts of Africa, Australia and Asia, but also inland (Tator, 1952a, 1953), and at high altitudes within mountainous areas, e.g. in New Mexico (Ogilvie, 1905) and Spain (Martin-Serrano, 1991). Pediments have been reported from many parts of the world, including such climatically contrasted regions as Alaska and the American Southwest, monsoonal Korea and southern England (Whitaker, 1973; Twidale, 1983a). Nevertheless, pediments are unquestionably well and widely developed in arid or semiarid regions of middle to low latitudes.



## B. MORPHOLOGY

### 1. General Statement

A pediment is a smooth, gently inclined, erosional surface (Figure 2.1). Inclinations of  $3^{\circ}$ - $4^{\circ}$  are typical, although slopes as little as  $0.5^{\circ}$  and as steep as  $10^{\circ}$  have been reported. Pediments meet the upland in a sharp break of slope, or piedmont angle, which is formed in bedrock, as distinct from those abrupt hill-plain junctions due to alluvial deposits lapping at the base of uplands (Figure 2.2). The trace of the piedmont angle at the foot of the mountain front may be linear or follow around spurs and embayments, in pediment passes (Howard, 1942). The required association of pediment and piedmont angle leads to a problem of definition if and when the backing scarp, and the upland it delimits, are eliminated. Does a pediment lose its identity when the upland disappears? The problem can readily, if arbitrarily, be decided in theory; in practice, however, it is not everywhere possible to determine whether an isolated platform was once a pediment backed by a scarp, or whether it is, for example, the crest of a recently exposed compartment of rock. For this reason, in this study, in order to qualify as a pediment, the planate form must display a piedmont angle and thus, implicitly, be backed by a scarp.

### 2. Areal Extent

The areal extent of pediments ranges from a few square metres for miniature forms (e.g. Bradley, 1940; Smith, 1958; Schumm, 1962) to hundreds of square kilometres. The extensive and smooth bedrock plains reported from several parts of the world are not necessarily associated with mountain ranges (e.g. Jutson, 1917; Berkey & Morris, 1927; King, 1942, 1953; Corbel, 1963; Mabbutt, 1967). By definition, then, they are not pediments; the cut bedrock surface is not associated with a piedmont angle, for there is no backing scarp. And, indeed, some workers consider that pediments of regional extent do not exist (Mabbutt, 1978; Twidale, 1983a). Instead, pediments are regarded as fringing forms, i.e. as features developed marginal to uplands (Mackin, 1970; Twidale, 1981).

In an upslope direction, the pediment is delimited by the position of the backing scarp. Recession of scarps may occur in favourable structural situations, e.g. where scarps are capped by resistant strata. This relationship was noted by the early surveyors of the Colorado Plateau, such as Powell (1875) and Dutton (1882), and has been confirmed by many others, including Glock (1936) and King (1942). Many workers, including Lawson (1915) considered that pediments extend headwards as a result of scarp recession. Local recession, certainly, is demonstrated by the development of pediment passes (Howard, 1942). Such developments are, however, limited where the bedrock of the upland is resistant (Rich, 1935; Bryan & McCann, 1936; Gilluly, 1937; Twidale, 1983a) and a piedmont suite of forms widely associated with granitic residuals signifies either slope stability or, at most, very, very slow retreat. Disposition of strata may also control the position of the scarp and hence the extent of the pediment. For example, where the scarp is a dipslope and the pediment surface is being lowered, the position of the piedmont angle migrates downdip and downslope (Twidale, 1972).

At the distal end or toe of some pediments the planate form is truncated by faulting (e.g. Williams, 1970; Bull, 1977). Alternatively, the toeslopes may be eroded by axial streams, i.e. streams which run parallel to the mountain front (e.g. Tuan, 1959). In places, basin fill has buried the toeslope, forming suballuvial benches (e.g. Balchin & Pye, 1955; Denny, 1967), thus shortening the pediment. Elsewhere, however, the benches have been exhumed, leading to a downslope extension of the form (Paige, 1912; Lawson, 1915; Tuan, 1962; Cooke, 1970).

### 3. Piedmont Angle

A piedmont angle, nick, knickpoint or angular break of slope eroded in bedrock is implicit in definitions of pediments and is requisite here. Several explanations for the piedmont angle have been offered.

Pediments are well developed in the tectonically active, faulted regions such as the American Southwest. This has led some workers to associate pediments with faulting. In

these terms the piedmont angle occurs at the junction of adjacent differentially dislocated blocks. Such fault-related angular junctions are preserved as the scarp retreats (e.g. Lawson, 1915; Rich, 1935; Bull, 1977), though no mechanism has been suggested. Moreover, the piedmont angle is found in areas and at sites where no faulting has occurred, as for instance around granitic inselbergs (e.g. Twidale & Bourne, 1978; see also Figure 2.3) and in effectively undisturbed sedimentary terrains (e.g. Twidale *et al.*, 1970).

Johnson (1931, 1932a & b) attributed the piedmont angle to undercutting and steepening of the mountain front by streams emerging from the upland. He argued that streams, debouching from uplands, deposit their load on losing gradient and divert themselves against the hill base, which is thus undercut and steepened (see also Paige, 1912). In reality, however, streams flow directly toward the basin or valley floor, and essentially normal to the upland front. It is true that where pediments occur within embayments (Figure 2.4), laterally migrating streams undercut and trim the sides of the adjacent uplands until the intervening spurs are eliminated (Johnson, 1932a; Howard, 1942; Parsons & Abrahams, 1984). Also, such a mechanism cannot account for the piedmont angle developed bordering uplands too small or too well fractured to generate runoff, a situation true of granitic inselbergs in many parts of the world (Figure 2.5).

Some of the hypotheses suggested in explanation of the piedmont angle require a break of slope between hill and plain for the proposed mechanism to operate. They require what they are supposed to explain before they can function. Such a criticism applies to the explanations invoking changes from turbulent to laminar flow of water (King, 1949, 1953), rill to wash (Waibel, 1928) and gravity versus wash processes (Lawson, 1915; Davis, 1930; Gilluly, 1937; Kirkby & Kirkby, 1974). Thus, to take one example, King suggested that the backing scarp was shaped by turbulent flow and the pediment by laminar flow, and that the piedmont angle marked the change in nature of flow. Apart from questions concerning the extent of laminar flow in natural conditions, the change of slope had to be in existence in order to produce the change in flow that would give the change in slope, i.e. the piedmont angle.

Rahn (1966) concluded that the most satisfactory explanation of the piedmont angle is that it was originally coincident with a tectonic or structural change, which may have been maintained during erosion and backwearing of the scarp (e.g. Rich, 1935; Twidale, 1967a, 1978; Bull, 1977). Thereafter the concentration of moisture, weathering and erosion at the scarp foot ensures the angularity of the hill-plain junction, the piedmont angle (Peel, 1941; Pugh, 1956; Twidale, 1967a). However, in the Tent Hills region of South Australia, for example, no such structural break influences the location of the hill-plain junction, save the resistant caprock of the plateau edge (Twidale *et al.*, 1970). The piedmont angle is developed in homogeneous rock (shale) in a flat-lying sedimentary sequence. The concentration of moisture and subsequent weathering and erosion of the rock in the scarp foot zone has been sufficient to etch out and maintain the piedmont angle (Twidale, 1967a).

#### 4. Pediment Surface

McGee (1897) first described the pediment as an eroded bedrock plain and seventy years later some workers restrict the term to bare rock surfaces (Cooke, 1970; Whitaker, 1973). More commonly, however, geomorphologists distinguish different types of pediment according to whether the country rock is exposed and the character of any cover that may be present.

Twidale (1981), for example, recognised three pediment types, each of a different origin: covered, mantled and rock. Such a classification can be applied to pediments irrespective of their age, topographic position or climatic situation. Covered pediments are characteristic of, though not exclusive to, sedimentary terrains, where the cut bedrock surfaces carry a veneer of allochthonous alluvial detritus (Figure 2.6). Mantled and rock pediments occur mainly in areas of crystalline outcrop (Figure 2.7), though they are not restricted to such lithological environments. A mantled pediment is veneered with weathered bedrock *in situ*. Where the mantle has been stripped, the weathering front is exposed as a rock pediment, or platform, that is, as an etch surface (see also Johnson, 1932a; Field, 1935).

Although pediments appear essentially smooth surfaces of erosion, most are intricately dissected (Mammerickx, 1964; Hadley, 1967). Fine drainage texture is typical of the upper slopes of pediments (Bryan, 1922; Gilluly, 1937; Doehring, 1970), for tributaries to dendritic stream systems rise on the escarpment and within the pediment surface itself. Rills, minor stream channels and other irregularities cut into the bedrock surface are infilled by detritus on covered and mantled pediments. The initial marks of channels and depressions developed at the weathering front may become blurred once the rock pediment surface is exposed, but those impressions near joints, for example, can be further exploited and significant relief established.

#### 5. Shape and Transverse Profile

In many areas transverse profiles of pediments, i.e. profiles drawn parallel to the line of scarp, and taken close to the mountain base, include convex-upward sectors indicating that the pediments are fan-shaped (Johnson, 1932a; Rich, 1935; Howard, 1942; Twidale, 1983a). Rectilinear transverse profiles were thought by some to be characteristic (Blackwelder, 1931; Fair, 1947, 1948; King, 1962), and this is true of areas where the individual pediments are fan-shaped but have coalesced to form an apron. Concave, scoop- or trough-shaped transverse profiles have also been noted (Bryan, 1936a; Gilluly, 1937; Tuan, 1959).

#### 6. Longitudinal Profile

Longitudinal profiles of pediments, i.e. profiles drawn normal to the line of scarp, are usually concave-upward (e.g. Paige, 1912; Bryan, 1922; Johnson, 1932a & b; Mammerickx, 1964). They are comparable to the thalweg of streams. This and direct observations have convinced most workers that streams are responsible for the erosion of the pediment surfaces. A concave upward profile is eroded because material can be transported over gentler gradients as the volume of flow increases downslope, and the pediment surface is regraded to accommodate a smaller transported load as the upland mass is reduced (Young, 1972). On the other hand, many pediments of mantled and rock types

are devoid of significant streams (e.g. McGee, 1897; Hadley, 1967; Whitaker, 1975). Even so, many workers report that the longitudinal slope tends to concavity where the pediment surface is subject only to rills, wash and gravity (Carson & Kirkby, 1972). That rectilinear pediment slopes occur in the study area, other South Australian sites (e.g. Twidale, 1966b, 1967b) and elsewhere (e.g. Cooke & Mason, 1973), deny these generalisations.

Pediments which form in enclosed basins or in valleys where the alluvium is not evacuated, were inferred to have convex-upward profiles. The argument is that detritus gradually fills the basin or valley as the mountain front regresses and suballuvial benches, or pediments, develop with convex-upward profiles (Lawson, 1915; see also Fisher, 1866; Wood, 1942). A similar profile was assumed to have developed beneath the peripediment of Balchin and Pye (1955). Convex-upward longitudinal profiles have been observed, but they appear to imply special circumstances (e.g. Davis, 1933, but also Sharp, 1957; Rich, 1935; Gilluly, 1937; Tator, 1952a, 1953; Twidale, 1966b). For example, local convexities in the profile have been attributed to renewed erosion of the toeslopes.

The longitudinal profiles of pediments are steeper opposite intercanyon areas than below canyon mouths (e.g. Bryan, 1922; Tuan, 1959) and outside smaller canyons (e.g. Gilluly, 1937; Sharp, 1940; Balchin & Pye, 1955), because lower gradients are associated with larger streams. Cooke (1970) showed that slopes are related to drainage basin relief and the length of a 'pediment association' i.e. the pediment, its drainage basin and that part of the alluvial plain to which it drains. There are slight changes of gradient along the length of the profile in some examples, but the slope essentially levels out near the toe of the pediment where it is overtaken by basin fill (Tator, 1952a, 1953).

Pediments are steeper where coarse and resistant debris occurs. The calibre of detritus diminishes with distance from the upland, but the orderly relationship between size of rocks in the pediment cover and pediment slope suggested by Lawson (1915) and many others (e.g. Bryan, 1922; Gilluly, 1937; Dury, 1966) has not been demonstrated (Mammerickx, 1964; Melton, 1965a; Cooke and Reeves, 1972). Mammerickx (1964) suggested that

cycles of pedimentation caused by climatic change or tectonism had disturbed any relationship between the gradient and pediment length, size of drainage basin and the nature of outcrop in the catchment.

### C. ORIGIN OF PEDIMENTS

Pediments are well developed and typical of arid and semi-arid regions, but pediments are found in many other climatic regions. Blackwelder (1931, p.138) described the pediment as "*the normal and inevitable form developed in the arid regions under stable conditions*". Bryan (1922) and many others, e.g. Bull *et al.* (1990), agreed that pediment development occurred during periods of landscape stability, even though the regions in which they worked were tectonically active. Only a relatively short period of time might be required to erode a pediment in less resistant strata. Whatever the optimum climatic or tectonic conditions are for the development of pediments, several theories for their origin have been proposed.

Some attributed pediments to lateral corrasion by streams (Gilbert, 1877; Paige, 1912; Blackwelder, 1931; Johnson, 1931, 1932a & b; and many others since including, for example, Twidale, 1987, and Osborn & du Toit, 1991). On leaving the confines of their upland gorges streams, fully loaded, divaricate over the piedmont plains, erode a gently sloping surface in the rock and at the same time deposit a cover of alluvium.

The water-sediment ratio carried by such a stream must vary in time and stream incision will alternate with lateral corrasion. Pediments commonly occur in flights. Some regard such pediments as having been 'born dissected' (Gilluly, 1937; Mackin, 1937), for strath development is inherent to the process of planation. Another possibility is that the dissection of the pediment surface is a function of stream regime, with planation taking place during high or flood flow, and incision of the stream channel associated with falling river levels (Mackin, 1937). Also, once the upland is reduced there is a decrease in supply of material to the laterally corradng streams so they incise their channels (Denny, 1967); but this seemingly is inapplicable to pediment development generally. Other workers

regard pediments as having been formed and then dissected in separate events. In these terms they are relic features (e.g. Moss, 1977). Whatever the origin of stepped topography, however, the higher surfaces must be older than the lower and may be of some antiquity (e.g. Dudley, 1936; Mackin, 1937; Rich, 1938; Miller, 1950; Twidale, 1978, 1981).

Pediments in sedimentary terrains are undoubtedly shaped by streams in flood. The summer cloudbursts which create those flood conditions are typical of, but not peculiar to, arid regions where pediments are best displayed (Russell, 1936; Twidale, 1987). Divaricating streams erode the bedrock surface and carry and deposit the alluvium which forms a pediment cover. However, portions of a pediment surface or, indeed, entire pediments, for example those surrounding inselbergs or boulder-size uplands, may never be crossed by streamfloods. Weathering and erosion has been effected by other means. Sheetflood, rill wash and other unconcentrated flow have been suggested as processes responsible for the erosion of pediments (McGee, 1897; Lawson, 1915; Berkey & Morris, 1927; Rich, 1935; Bryan, 1936b; and others including the summation by Hadley, 1967). No-one has demonstrated that spreads or unchannelled waters erode pediment surfaces. However, rills and wash effect weathering of the bedrock and production of a mantle in crystalline terrains and some detritus is moved across pre-existing pediment surfaces.

Scarp recession and the reduction and eventual elimination of the upland and the development of the pediment has been advocated many times since McGee (1897) wrote of retrogressive erosion of the mountain front (e.g. Lawson, 1915; Rich, 1935; Blissenbach, 1954; Hadley, 1967; Bull, 1977). The concept found its most enthusiastic supporter in King (1949, 1953, 1966, 1968), who developed the theory of parallel scarp retreat and pedimentation in explanation of landscapes of regional and even subcontinental extent. King (1953, 1957) considered the pediment the dominant planate form wherever the land surface is shaped by running water and he linked it genetically with scarp recession (King, 1942, 1953, 1957, 1962); though these claims have been called to question (e.g. Carson & Kirkby, 1972; Twidale, 1983a) and they are not borne out by the field evidence. No remnants of former land surfaces ought to survive scarp retreat, and yet very ancient, very



extensive surfaces remain, for example, in the Australian landscape (Twidale & Campbell, 1988, 1992). Moreover, there is convincing evidence for long-term slope stability (e.g. Twidale, 1962, 1982b; also Partridge & Maud, 1987).

In some regions pediments were interpreted as exhumed suballuvial benches (Paige, 1912; Lawson, 1915; Balchin & Pye, 1955; Tuan 1959). Tuan (1959) developed the idea that, as the mountain front receded and the uplands were degraded, the pediment was widened by stream erosion, the slope gradually declining in response to the decreased amount and rate of alluviation. The enmeshed drainage pattern of the alluvial apron later became a denser pattern of sub-parallel streams, augmented by streams rising on the pediment itself, which bared the suballuvial bench and continued to degrade the pediment. The suballuvial bench was not, therefore, simply exhumed but modified by a new stream regime (cf. Field, 1935).

Many of the pediments reported from the American Southwest (McGee, 1897; Bryan, 1922; Mackin, 1937; Tuan, 1959; Oberlander, 1972, 1974) and elsewhere are cut in crystalline rocks and mantled with weathered granite *in situ*. Relatively thin mantle material retains moisture and may effect the erosion of pediment surfaces by means of mantle-controlled planation (Mabbutt, 1966; cf. 'ground-level trimming' Bryan, 1925). Where the mantle is stripped away the weathering front is exposed as an etch surface, a rock pediment (Twidale, 1981). Such rock pediments are confined to the scarp foot zone. Some of the backing scarps are flared and are associated with scarp foot depressions, both of which forms argue locational stability of the scarp (Clayton, 1956; Twidale, 1962). Also any backwearing of the scarp through scarp foot weathering is minimal, a few tens of metres at most and is due to subsurface weathering, not epigene stream erosion (Twidale & Bourne, 1975; Twidale, 1978, 1982b).

The allochthonous detritus which forms the alluvial cover on some pediments can be explained no matter which theory of pediment development is advocated. Alluvium in the form of point bar and channel bed deposits is left behind on the surface if streams laterally corrade a pediment (e.g. Gilbert, 1877; Davis, 1930; Blackwelder, 1931; Johnson, 1931, 1932a & b; Sharp, 1940; Osborn & du Toit, 1991). Alluvium can be deposited on the

pediment in sheetflood or sheetwash (e.g. McGee, 1897; Blackwelder, 1928; Davis, 1938; Rahn, 1967), although few consider that the surface can be eroded by such spreads of water. Gradual burial of the pediment by basin fill can supply an alluvial cover (Paige, 1912; Lawson, 1915; Bryan, 1922; Tuan, 1959). In some places bare rock pediments have been attributed to the recession of scarps and the efficient removal of debris, and described as slopes of transportation (Johnson, 1932a; Field, 1935; Gilluly, 1937). In these terms the pediment cover is detritus in transit and Schumm (1977) described the covering of a pediment by stream deposits as a separate process from its erosion.

Pediments are explained in terms of various contemporary mechanisms and processes. Bryan (1922) was, perhaps, the first to acknowledge that all the processes suggested by his predecessors might be active in pediment formation in varying degrees. This composite approach was adopted by many others (e.g. Davis, 1930; Field, 1935; Gilluly, 1937; Sharp, 1940). Processes at work in the landscape, may be modifying rather than forming the pediments, as charged by Cooke *et al.* (1993), but even if a pediment is relic from a period of contrasting climatic conditions similar forms are being eroded in that climate today. Certainly, the erosional nature of a pediment surface means that much of the possible evidence concerning its development has been removed. Such doubts do not concern workers studying alluvial fans and their origin, because that landform embodies the processes by which it has accumulated.

### III. ALLUVIAL FANS

#### A. GENERAL STATEMENT

Although Drew (1873) was the first to use the term 'alluvial fan', in his study of the upper Indus Basin, Surell (1841: cited in Bull, 1977) is credited with being the first to discuss the feature. Subsequently, alluvial fans were recognised from other regions (Gilbert, 1875, 1877, 1890; Dutton, 1880; Geikie, 1886; McGee, 1897; Davis, 1905; Eckis, 1928). Alluvial fan sediments, or fanglomerates, have also been identified in the stratigraphic column and have been used, in particular, as indicators of vertical tectonics and/or arid to

semi-arid climates (Bull, 1977; Miall, 1981; Galloway & Hobday, 1983; DeCelles *et al.*, 1991).

Review and assessment of alluvial fans date from the middle of the Twentieth Century (e.g. Blissenbach, 1954; Beaty, 1963; Denny, 1965; Hooke, 1967; Bull, 1977; Rachocki, 1981; Nilsen & Moore, 1984; Lecce, 1990). Alluvial fans are developed in every climatic setting from the arctic to the tropics (see e.g. Bull, 1977; Nilsen & Moore, 1984; Rachocki & Church, 1990), but a disproportionately large number of publications have been based on three localities in the American Southwest, viz. western Fresno County and Death Valley, both in California, and the White Mountains of California and Nevada. The resultant publications, which are considered to be seminal works in the alluvial fan literature, are concerned exclusively with closely juxtaposed arid to semi-arid, tectonically active, regions (Lecce, 1990). In some measure, the structural and climatic setting of these areas have been taken as typical of all alluvial fans (Figure 2.8).

## B. MORPHOLOGY

### 1. General Statement

Alluvial fans are thick accumulations of detritus shaped like a partial cone, and deposited by streams in the piedmont zone of an upland. In its simplest form the alluvial fan radiates out downslope from the point, or narrow sector, where a stream emerges from the upland. Each fan is related to a particular network of streams eroding a drainage basin through a single trunk stream.

Alluvial fans comprise several segments or lobes, and the surface is subjected to phases of erosion and deposition over time for the locus of deposition shifts laterally and up and down the fan surface. The proximal parts of alluvial fans are separated from those of adjacent fans by interfan depressions, whereas their lower slopes commonly coalesce to form an alluvial apron or bajada (Blackwelder, 1931; Ruhe, 1964).

## 2. Fan Deposits

The composition of alluvial fan deposits is determined by the bedrock exposed in the associated catchment, the degree and type of weathering, changes due to transport of the material and changes effected after deposition of the alluvium. Sediments range in calibre from boulders to clay. Maximum and mean particle sizes decrease downslope (e.g. Blissenbach, 1954; Beaty, 1963; Bull, 1964a; Bluck, 1964; Ruhe, 1964; Hooke, 1967; Bull, 1977). Sorting increases with distance from the source and secondary fans, derived from the reworking of alluvial fan deposits, are comparatively well-sorted (Blissenbach, 1954).

Alluvial fans comprise either streamflow or debris flow deposits or a mixture of both (e.g. Bull, 1964a; Ryder, 1971; Wasson, 1977a; Wells & Harvey, 1987; Mukerji, 1990; Sah & Srivastava, 1992). Most are built of fluvial sediments (Trowbridge, 1911; Blissenbach, 1954; Melton, 1965b; Williams, 1970), but others are dominated by mudflow or debris flow deposits (Blackwelder, 1928; Beaty, 1963, 1970; Bluck, 1964; Ryder 1971; Van Overmeeren & Staal, 1976). Aeolian, lacustrine and other fluvial sediments may be incorporated in the fan deposits (e.g. Larsen & Steel, 1978).

Fanglomerates display vertical and horizontal variations according to the origin of the deposits (Trowbridge, 1911; Bull, 1977; Harvey, 1989; Lecce, 1990). It is possible to trace a specific bed for some distance downfan but, in cross section, the bed becomes attenuated and lenses out or abuts an infilled channel deposit (Figure 2.9). Fluvial deposits are well sorted, usually in upward-fining sequences, and may display imbrication and current bedding, with cut and fill features. Mudflow deposits, on the other hand, form solid layers, alternating with stream gravels, and are generally found in the distal parts of an alluvial fan. Debris flow deposits with a mud matrix may be intercalated with stream deposits and tend to be restricted to the upper fan above the intersection point. They are less well sorted than stream flow deposits. Sieve deposits are like debris flows but lack primary fines (Figure 2.10). They are lobes of coarse detritus which act as strainers so that water carries any fines out and downslope (Hooke, 1967; Wasson, 1974; Bull, 1977).

Secondary depositional features due to subsidence, soil creep, pedogenesis, growth of vegetation and disturbance by animals are also widely developed (Bull, 1962a; Denny, 1967; Gostin & Rust, 1983; Harvey, 1987).

### 3. Fan Size

Alluvial fans are typically 5-20 times longer than they are wide. The maximum size of an alluvial fan is determined by the space available for its deposition in the basin or valley. Other than this restriction, the size of an alluvial fan is related to the size of its drainage basin, which, in simple terms, determines the amount of sediment available (Denny, 1965; Hunt & Mabey, 1966). Some very large basins are, however, associated with disproportionately small alluvial fans. Several factors, related to the size and maturity of such a catchment have been cited in explanation. The whole basin is unlikely to be covered by a single storm event, more sediment in transit can be stored in a large basin, greater discharges may flush the sediment beyond the alluvial fan and, in time, sediment supply is decreased as uplands are reduced and slopes are less steep within the catchment (Hooke, 1968; Bull, 1972; Lecce, 1990; Cooke *et al.*, 1993).

Denny (1965) observed that fan size was directly related to the lithology of the source area (see also Bull, 1968; Hooke, 1972) and to the height of the source area above the fan (see also Melton, 1965b; Van Overmeeren & Staal, 1976). Rates of sediment supply are directly related to lithology, for rock type and its susceptibility to weathering processes determine the volume of sediment available for transport. For example, some alluvial fans derived from mudstone and shale basins are twice as large as those from the same size basins cut in sandstone (Bull, 1962a). Also alluvial fans built of coarser sediments are steeper and relatively limited in extent.

### 4. Fan Slope

An alluvial fan is a segment of a cone with a convex-upward transverse profile and the flanks of alluvial fans are commonly steeper than the longitudinal, or axis, slope (Hooke &

Rohrer, 1979). The length of alluvial fans varies from tens of metres to many kilometres (Eckis, 1928; Blissenbach, 1954; Reineck & Singh, 1973; Bull, 1977), and the average gradient of the largest fans is so gentle as to be less than one degree. The axis slope is inversely proportional to fan area and fan radius (Hooke & Rohrer, 1979). Minor alluvial fans of predominantly coarse deposits and talus cones, for example, have steep slopes and short radii (e.g. Bull, 1977).

The longitudinal profile echoes the concave-upward thalweg of a stream, and is affected by such variables as debris size, water-sediment discharge, drainage basin morphology and rate of sediment production (Blissenbach, 1952; Troeh, 1965; Bull, 1968; Lustig, 1969). The steepest slope is near the mountain front, though it is most commonly less than  $10^\circ$  (Cooke & Warren, 1973). The initial proximal slope of an alluvial fan is an extension of the stream gradient. However most alluvial fans are complex forms. Fanhead trenching invariably leaves intact the earlier steeper profile of the slope of the upper fan and the stream emerges downslope at the intersection point emerges downfan at the intersection point, i.e. where the gradients of stream channel and fan surface coincide (Hooke, 1967; Bowman, 1978; Harvey, 1987). In detail, the longitudinal profile most commonly consists of a series of straight segments rather than an arc or a parabola. This demonstrates that the fan has been deposited as a series of lobes, or segments, superimposed one on the other and laid down by streams flowing over the surface (Bull, 1964b; Hooke, 1972), rather than in a single period of accumulation. Such a profile may result from dissection of an alluvial fan (Blissenbach, 1954). Segmentation results from uplift of source areas or from changes in water sediment discharge induced by climatic changes (Bull, 1964b, 1968).

The axis slope of an alluvial fan is inversely related to the area of the drainage basin serving the fan (Bull, 1962a, 1964b) and to discharge (Hooke, 1968). Melton (1965b) correlated fan gradient with ruggedness, a measurement of relative relief within each basin area. The lithology of outcrop within the catchment determines the nature and supply of detritus, and given the prevailing climatic conditions the effective processes of erosion and transport and the rate of delivery of sediment to the fan. Thus, steeper fans are associated with high sediment production from the upland, debris flow rather than stream flow deposits, low

discharges, and coarse-grained deposits (Eckis, 1928; Blissenbach, 1954; Bluck, 1964; Bull, 1962a, 1964a & b, 1968; Hunt & Mabey, 1966; Hooke, 1967, 1968; Van Overmeeren & Staal, 1976; Hooke & Rohrer, 1979).

### C. ORIGIN OF ALLUVIAL FANS

Alluvial fans are deposited by unconfined streams, because of changes in the hydraulic geometry of flow (Bull, 1964a). When streams emerge from the upland, or at an intersection point out on the fan, their channels are no longer confined and they spread out over the piedmont plain. Stream depth decreases, channel width and wetted perimeter are increased, and energy is lost. Velocity of the stream decreases and solid load is deposited. Where the underlying strata are permeable, subsurface infiltration of water also induces sedimentation.

Debris is transported across the fan surface primarily by flows of water and sediment in radiating channels (Hooke, 1967). Within a single flood event or over several seasons, the loci of deposition move up and down the fan along the radiating stream lines (Buwalda, 1951; Denny, 1967; Hooke, 1968), and also laterally as flows are diverted to lower areas (Bull, 1977; Hooke & Rohrer, 1979). Overbank flow occurs when channels are backfilled by their own deposits, when channels are blocked by debris flows or by large individual boulders and as a result of lateral erosion and bar-building in the main channel. Thus the alluvial fan is gradually built up, segment by segment.

It has been suggested that alluvial fans accumulate when the baselevel of the lowland or depositional area falls in relation to that of the upland or erosional area. As a result the alluvial fan deposit thickens downslope (e.g. Blissenbach, 1954). Other fans form lenticular masses where the midfan area has received more sediment (Bull, 1977). However, most fans are thickest near the apex and taper downfan. Such wedge shapes have been taken to indicate tectonic movement and an increased sediment supply with uplift of the mountains. Alluvial fans of this shape have been described as 'orogenic' (Bull, 1977).

#### D. ALLUVIAL FAN DISSECTION

The reasons for the dissection of the upper part of alluvial fans, variously referred to as trenching (e.g. Eckis, 1928; Weaver & Schumm, 1974; Harvey, 1987), intrenchment (Buwalda, 1951), entrenchment (e.g. Bluck, 1964; Mukerji, 1990) and incision (e.g. Williams, 1970; Wasson, 1977b), has given rise to much debate. Eckis (1928) and later Blissenbach (1954) attributed the dissection of the fanhead to the normal course of a cycle of alluvial fan development as the upland stream is first graded to its own deposits but then floodwaters cut a single channel through them and deposits material further downfan. Factors thought to cause dissection of alluvial fans include several which affect only the associated catchment, e.g. variations in flood discharge due to capture of all or part of an adjacent catchment (Eckis, 1928), extreme rainfall events (Bull, 1964b; Denny, 1967; Beaty, 1974), deforestation and overgrazing (Williams, 1970), and decrease in the available sediment load, for example, if less readily weathered bedrock were exposed in the catchment. Other factors include climatic change (Lustig, 1965; Williams, 1973), baselevel shifts (Eckis, 1928; Tator, 1952b; Wasson, 1977b) and tilting and faulting (Eckis, 1928; Wahlstrom, 1947; Bull, 1964b; Denny, 1967; Hooke, 1972). The notion that the natural growth of an alluvial fan involves periodic dissection and fill (Denny, 1967; Schumm *et al.*, 1987) may be sufficient explanation, even though the changes mentioned have caused dissection of the particular alluvial fans.

#### IV. COEXISTENCE OF PEDIMENTS AND ALLUVIAL FANS

Pediments and alluvial fans occur in the piedmont zone of many upland regions, and according to many of the early interpretations, pediment development preceded the deposition of alluvial fans. For example, Gilbert (1877) believed that once the pediment had been eroded by lateral corrasion and covered with alluvium deposited by the shifting stream channels, cones of alluvium were deposited at the mouths of mountain gorges after sudden storms, choking the channels and diverting the streams to form new courses. McGee (1897) described some of the planed granite surfaces, or pediments, as 'rubble-cumbered slopes' mantled with 'a torrential veneer', and observed that valley interiors and



the lower lowlands were built of 'torrent-laid debris': a few permanent streams within the sierras flowed out on to the plain or streams flowed after 'cloudbursts or thundergusts', first into flat-bottomed barrancas cut in country rock and lined with boulder beds, then through arroyas eroded in alluvium and ending in alluvial fans.

More recently, Blissenbach (1954) interpreted the downslope thickening of alluvial material as the deposition of an alluvial fan over the pediment (cf. fan-topped pediment of Blackwelder, 1931). Williams (1969) identified an ancient pedimented landscape buried by late Precambrian conglomerate at an unconformity in northwest Scotland and has reported similar, but much younger, landform assemblages elsewhere. He described Pliocene and Pleistocene terraces and erosional surfaces, which may be pediments, overlapped by, or faulted against, coalescing alluvial fan deposits of Quaternary age from northern Africa (Williams, 1970). He also reported Early Pleistocene gravel-capped pediments forming terraces and dissected coalescing fans from South Australia (Williams, 1973). Harvey (1990) noted that fans in the southeast of Spain rest on, or are inset within, and therefore postdate, Pliocene to early Quaternary pediments.

On the other hand, alluvial fans which predate coexisting pediments have also been recorded. Tuan (1959, 1962) explained that headward extension of alluviation kept pace with stream erosion as it indented the mountain front and isolated former spurs as outliers of the mountain mass. The latter were eventually reduced by denudation to form pediments. Bull (1977) also described pediment surfaces developing as the mountain front retreated from a buried fault scarp in the basin-and-range structural setting. The pediment is partly eroded across basin fill, which includes alluvial fan deposits. Therefore the pediment is younger. In Arizona, alluvial fans stand higher and more distant from the scarp than the pediments and are, therefore, older than the erosional forms (Bull *et al.*, 1990).

According to Blackwelder (1931) streams in the process of achieving grade deposit alluvial fans. Thus, alluvial fans are deposited either after the initial uplift when upland and plain are established, or following some disturbance to the system caused by tectonism or

baselevel shift. Their formation may, therefore, predate or follow the development of pediments, which he thought were cut by streams at grade. The coexistence of alluvial fans and pediments in most desert piedmonts convinced Denny that "*processes of erosion, weathering, and deposition are all in operation at the same time. It is only the relative intensity of these processes from place to place that has changed...*" (Denny, 1967, p.96). Certainly the examples of investigations mentioned here suggest that the relative ages of pediments and alluvial fans vary regionally, and even in time.

## CHAPTER THREE

### PEDIMENTS IN THE WESTERN PIEDMONT OF THE FLINDERS RANGES

#### I. INTRODUCTION

The purpose of this chapter is to describe and consider the origin of pediments developed in the western piedmont of the Flinders Ranges. They can then be compared genetically to the alluvial fans with which they coexist (Chapter Four). The distribution of pediments and alluvial fans in the study area is illustrated on two morphological maps (Figures 3.1 & 3.2). Remote sensing imagery, thickness of the alluvial deposit and catchment characteristics were the most useful criteria for distinguishing pediment from alluvial fan. These elements and others which provided supportive data are discussed in Appendix I.

Pediments are prominent in two sectors of the study area. In the inner piedmont of the Heysen Range between Parachilna and Edeowie, pediments and pediment remnants occur side by side at different elevations to produce a stepped topography. The lowest elements of which are still in process of formation, whereas the others are being reduced in area. The pediments in the inner piedmont of the Wyacca-Emeroo ranges are much dissected and constitute only a minor constituent of the landscape.

With two minor exceptions, viz. the rock pediments of Aliena and Pettana (see Chapter Five), the pediments of the western piedmont are of covered type (Twidale, 1981), that is, the cut bedrock surfaces are masked and protected by 1-2 metres of allochthonous material. The pediment remnants of the study area stand up to 50 metres above present baselevel, represented by local stream channels. They are smooth and slope gently down at angles between 1°-6°, and typically in the range 3°-4°, from the backing scarp, which they meet in an abrupt break of slope, or piedmont angle. They extend to a maximum of 4 kilometres from the scarp foot to probable faulted margins, where their alluvial cover merges with alluvial fan and other sedimentary deposits of the Torrens Plain.

## II. REGIONAL ACCOUNTS

### A. PARACHILNA-EDEOWIE REGION

#### 1. Pediments

The Parachilna-Edeowie pediments occur within the inner zone of the western piedmont of the Heysen Range and fringe that upland. They comprise a series of gently inclined fan-shaped plains which merge laterally to form an apron. The pediments are eroded across Cambrian strata, dipping west at 40°-70°, and dominated by siltstone, but including beds of limestone and sandstone. Pediments and pediment remnants occur in three elevational zones: high, low and intermediate (Figure 3.1). The intermediate is the most extensive and is referred to as the main pediment. It will be described first to provide information equally applicable to the other pediment levels, but not so well illustrated by them because of their limited occurrence. Only remnants of higher, older pediments have survived and the lowest pediments occur in the vicinity of the major streams. All the relic pediments stand at elevations greater than the apices of the major alluvial fans associated with the Parachilna, Brachina, Bunyeroo and Aliena creeks.

##### (a) Main Pediment

###### (i) Shape

The main pediment comprises a series of low-angle partial cones or fans, the apex of each coinciding with the point, or narrow zone, of debouchment of a stream from the upland. Parallel with the upland front between Parachilna and Brachina creeks where the pediment apron is intact, the transverse profile comprises convex-upward sectors, reflecting the presence of pediment fans, most of which have coalesced laterally to form a pediment apron (Figure 3.3). The plan outline of the pediment fans has in places been emphasised by the erosion of lateral channels. For example, tributaries of streams dissecting the surface between those sections of the pediment associated with Barregowa, Bathtub and Hayward

creeks have removed weathered material from the scarp foot and delineate the partial cones of the main pediment seen in transverse profile (Figure 3.4). In the vicinity of Brachina and Bunyeroo creeks they, and their tributaries, have so eroded the main pediment that much of the surface consists of low rises and dissected hill areas with some mesas separated from the upland by scarp foot valleys (Figure 3.5).

(ii) Length

The length of the main pediment, i.e. the distance normal to the hill face, is of the order of 2 kilometres, but it varies from only 1200 metres near the mouth of the Parachilna Gorge to some 3.6-4.0 kilometres, in the vicinity of Brachina and Bunyeroo creeks (Table 3.1). Pediment length is obviously determined by the line of the hill-plain junction on the one hand, and the western limit of Cambrian outcrop, which is probably a degraded fault scarp, on the other (see Chapter One). Regression analysis shows that there is no relationship between pediment length and the length of the associated drainage basin, nor between pediment length and the area of catchment (Appendix II: Pediments). It is suggested, therefore, that the toeslopes of the pediments are truncated by faulting (see also Williams, 1973).

(iii) Piedmont Angle

Large sections of the main pediment meet the backing scarp in an abrupt break of slope, typically from 3-4° to 22° (Figure 3.6a). Its position is traced more-or-less by the 300 metre contour line. The scarp face corresponds to the dipslope and the piedmont angle is approximately coincident with a lithological boundary. In detail, the break of slope is eroded in the siltstone and shale adjacent to the limestone of the backing ridge. Projection of the high pediment surface levels to breaks of slope on the scarp confirm that the piedmont angle has always corresponded to such a lithological boundary (Figure 3.6b & c). The position of the hill-plain junction has advanced to the west because of the dipslope of the strata, which underlies and gives form to the slope of the upland margin (Twidale, 1972).

Where streams have removed deeply weathered bedrock, for example between Brachina and Bunyeroo creeks (Figures 3.5 & 3.7; see also Figure 3.27, eastern margin of Edeowie Pediment), scarp foot valleys separate the pediment from the backing upland. Former hill-plain junctions related to such pediment remnants are invariably marked by weathered (kaolinised) bedrock, but the projected level of the surface can be linked to breaks of slope, pediment remnants perched on the scarp face, and to breaks below valley-side facets in adjacent gorges and valleys. Thus the piedmont angle in the Parachilna-Edeowie region is due to exploitation by weathering and erosion of lithological boundaries.

#### (iv) Slope

In longitudinal profile, taken normal to the scarp, the pediment fans are sensibly rectilinear. The surface gently slopes at  $3^{\circ}$ - $4^{\circ}$  away from the scarp foot (Figure 3.8, Table 3.1) and stands some 10-30 metres above present creek beds. The gradient of the stream profiles is comparable, e.g. Hayward Pediment has a slope gradient of 150 metres over 3 kilometres, i.e.  $2^{\circ}52'$  and the profile for Hayward Creek is  $2^{\circ}27'$ .

#### (v) Pediment Cover

Alluvial and colluvial material derived from the backing upland covers the surface of the main pediment to a depth of up to 2 metres. The underlying bedrock surface is irregular in detail (Figure 3.9), but the pediment surface appears smooth (Figures 3.6a & 3.10), as a result of deposition of alluvium probably by laterally migrating streams. The bulk of the cover consists of subangular blocks, boulders and cobbles of quartzite, sandstone and limestone, with minor amounts of local argillite, up to 20cm diameter and comparable in size and degree of roundness to the load carried in present stream channels (Figures 3.11). Close to the scarp, most of the larger rocks of the pediment cover are derived from the front ridge of fossiliferous limestone. They are subangular and have moved a short distance under gravity and wash. Limestone cobbles and boulders display dimpling and fluting typical of solutional weathering. Some sandstone blocks are planed off flush with the surrounding pediment surface (Figure 3.12a). Others are split into angular blocks

Table 3.1 (1 of 2) Drainage Basins and Pediments: Parachilna-Edeowie region,  
Parachilna-Brachina sector of Heysen Range piedmont.

STREAM		DRAINAGE BASIN									PEDIMENT			
CODE	NAME	FREQUENCY km	AREA km <sup>2</sup>	BEDROCK % L/S S/S		Sh/Si	LGTH km	H/P m	H m	R/R H/√A	LEVEL	SHAPE	LENGTH km	SLOPE x°
1	PARACHILNA	0	599.00	-	5	95	21.5	817	567	.023	-	-	-	-
2	Parachilna tributaries	-	<1	50	50	0	1.3	622	-	-	main	contiguous	1.2	2.9
3	Parachilna tributary	4.5	2.68	63	37	0	1.8	792	402	.246	-	-	-	-
4	Parachilna tributary	1.0	2.81	67	33	0	1.8	784	534	.318	-	-	-	-
5	Five Mile	1.8	9.13	11	44	50	3.8	817	517	.171	-	-	-	-
6	Barregowa North &	0.8	1.15	67	33	0	1.5	624	324	.302	main	dissected	2.0	2.7
7	Barregowa South	0.7	3.41	28	43	29	2.0	697	397	.215		fan		
8	Tea Cosy	1.3	4.61	22	45	33	3.3	750	450	.210	-	-	-	-
9	Warekila & tributaries	-	<1	55	45	0	2.0	801	501	-	main	dissected	2.0	-
10	Bathtub	3.6	5.04	10	40	50	3.8	804	504	.224	main	dissected	3.2	-
												half fan		
11	Bundulla tributary	1.2	1.02	100	0	0	1.8	608	308	.305	main	dissected	2.0	2.6
12	Bundulla tributary	1.2	1.23	100	0	0	0.8	690	290	.261	main	dissected	2.0	-
13	Bundulla	1.5	3.75	14	57	29	2.8	758	408	.211	high	few remnants	1.4	-
											main	dissected	2.4	
14	Walkandi tributary	1.2	3.07	8	67	25	2.3	820	470	.268	high	few remnants	1.6	-
											main	dissected	2.2	
15	Walkandi	1.2	1.56	50	50	0	2.0	865	515	.426	high	few remnants	0.8	-
											main	dissected	2.2	
16	Hayward	0.6	1.52	33	67	0	2.0	865	525	.426	main	fan	2.6	2.9
17	Ilina North	1.7	2.94	58	42	0	2.3	854	534	.311	-	-	-	-
18	Ilina South	1.6	2.84	67	33	0	2.5	810	540	.320	main	contiguous	0.8	-
19	BRACHINA	1.2	350.00	0	7	93	21.0	865	615	.033	main	dissected	3.6	3

Key: Table 3.1

CODE	Drainage Basins numbered 1-30 in Figure 3.20
STREAM FREQUENCY	Linear distance of gorge mouth from that to the north
BEDROCK	L/S: Wilkawillina Limestone, Cambrian, massive archaeo- cyathid limestones, dolomitic and sandy at base. S/S: mostly Pound Quartzite, upper Proterozoic member, resistant quartzite with minor shale bands over feldspathic sandstones. Sh/Si: various shales and siltstones, in part calcareous or dolomitic, Proterozoic formations including diapiric material
LENGTH	Length of drainage basin measured parallel to trunk stream
H/P	Highest Point within drainage basin
H	Height or relief amplitude is difference between highest point and altitude of hill -plain junction
RR	Relief ratio, or degree of ruggedness, as calculated by Melton (1965), i.e. Height over /Area of drainage basin.



Table 3.1 (2 of 2) Drainage Basins and Pediments: Parachilna-Edeowie region, Brachina-Aliena sector of Heysen Range piedmont.

STREAM		DRAINAGE BASIN									PEDIMENT			
CODE	NAME	FREQUENCY km	AREA km <sup>2</sup>	BEDROCK %			LGTH km	H/P m	H m	R/R H/√A	LEVEL	SHAPE	LENGTH km	SLOPE x°
				L/S	S/S	Sh/Si								
19	BRACHINA	1.2	350.00	0	7	93	21.0	865	615	.033	main	dissected	3.6	3.0
20	Brachina tributary	-	<1	77	23	0	<2.0	630	400	-	main	dissected	3.6	-
21	Brachina tributary	4.6	3.35	67	33	0	2.0	628	328	.179	main	dissected fan	4.0	1.6
22	Bunyeroo tributary	1.5	2.44	80	20	0	1.5	605	305	.195	main	dissected	3.6	-
23	BUNYEROO	2.2	127.00	0	15	85	13.0	861	561	.049	'high'	part fan	2.4	2.0
											main	dissected	4.0	3.0
24	Unnamed	2.6	1.98	63	37	0	1.8	633	333	.237	main	dissected	2.4	-
25	Unnamed	0.3	1.21	42	58	0	1.8	633	333	.303	main	dissected	2.4	-
26	Unnamed	0.9	2.51	60	40	0	1.8	721	420	.265	main	dissected	2.4	-
27	Unnamed	1.8	4.72	36	64	0	2.5	861	560	.258	-	-	-	-
28	Edeowie	2.6	18.92	0	100	0					main	dissected	2.8	2.6
							4.8	1150	850	.195		half fan		
29	Aliena tributaries	-	<1	0	100	0					-	-	-	-
30	Aliena	6.0	11.27	0	38	62					high	dissected	1.2	6.0
							2.5	1150	750	.223	rock		1.0	4.0
											main	dissected	2.2	3.0

(Figure 3.12b). The quartzite debris is more weathered than the limestone because waters saturated with lime flushed from the backing scarp of Wilkawillina Limestone attack the quartzite and leave it fretted, hollowed out and bevelled. The coarse debris sits in a matrix of fine sand and silt (Figure 3.12c), in places cemented by lime. Shallow palaeodrainage lines, marked by particularly coarse debris, run down the pediment slope (Figure 3.11c), but the development of gilgai in the pediment cover precludes their survival for the most part.

Although the thickness of the pediment cover can be observed in creek cuttings, it might vary, across the pediment surface, between stream lines. For example, seismic surveys carried out on the 'erosional terraces' described by Mackin (1937) revealed a considerable bedrock micro-relief (Moss & Bonini, 1961; Ritter, 1978). Again, the thickness of alluvial cover on the Ralston 'Pediment' near Boulder, Colorado, varies between 2 and at least 15 metres within a short lateral distance (W. C. Bradley, pers. comm., 1993; Figure 3.13). In order to test the situation in the study area, part of the main covered pediment surface associated with Hayward Creek was investigated. Two metres of alluvium over the bedrock surface cut across steeply dipping shales was first described by Twidale (1967b, 1979) from exposures in the banks of streams dissecting the landform a kilometre from the scarp foot (Figure 3.11a). Later a trench dug in the surface midway between unnamed creeks about 400 metres from the scarp foot passed through a similar depth of alluvium before encountering weathered bedrock.

Confirmation that the thickness of the alluvial cover was consistent over the Hayward Pediment was obtained by taking a shallow seismic refraction survey across the surface some 500 metres downslope from the piedmont angle (Figures 3.10a, 3.14 & 3.15). The pediment cover (velocity:  $490 \pm 150 \text{ ms}^{-1}$ ) was shown to vary from 1.3 to 1.8 metres in thickness (Figure 3.16a, Table 3.2; see Appendix III for detailed report). In broad view, the smooth surface of the alluvial cover simulates the surface eroded across the dipping Cambrian bedrock. In detail the cut bedrock surface is uneven and the thickness of the cover varies accordingly. These irregularities are explicable in terms of the minor relief and cut and fill features exhibited by modern braided channels in the region.

Table 3.2 Summary of shallow seismic refraction survey results (see Appendix III for results in full).

SHALLOW SEISMIC REFRACTION SURVEY								
LINE	G.R.	BEARING °	SLOPE °	V1 ms <sup>-1</sup>	THICKNESS metres	V2 ms <sup>-1</sup>	THICKNESS metres	V3 ms <sup>-1</sup>
TEST	TL651333	230	6	450	1.6-2.5	2280		
P1	TL649337	135	0.5/1	590	1.8	1100	6.5+	
P2	TL645342	135	0/0.5	400	1.7	1000	12.6	2300
P3	TL647338	135	1	400	1.6	1350	6.3	3000
P4	TL648338	135	0	440	1.3	1300		
P5	TL647338	225	3	390	1.3	1400	~10	3000

**Key: Table**

TEST            Test line (see inset map A; Figure 3.10)  
P1-5            Survey lines on Hayward Pediment (see inset map A: Figure 3.10)  
G.R.            Grid Reference: 1:50 000 Topographic Series, map sheet 6635-3  
                  *Oraparinna*  
BEARING        Orientation of survey line  
SLOPE          Gradient of surface  
V1-3            Velocity of signal  
THICKNESS     Distance between refractive layers

Beneath the cover, and shown in three of the survey lines, there is a zone of increased velocity ( $1250 \pm 100 \text{ ms}^{-1}$ ), 6.3-12.6 metres thick, over another returning an even faster signal ( $2650 \pm 350 \text{ ms}^{-1}$ ). This was interpreted as an altered bedrock zone, comparable to that located in the excavation referred to earlier, over unweathered bedrock. Fresh country rock crops out in the beds of streams dissecting the surface to similar depths. The increase in depth in the weathering front adjacent to stream lines on either side of the Hayward Pediment is consistent with the presumed behaviour of the water table (Figures 3.16a & b).

(b) High Pediment

(i) Bundulla-Walkandi High Pediment

Remnants of a high pediment or flight of pediments, first described by Twidale (1967b), occur west of Mount Hayward and on the drainage divide between Parachilna and Brachina creeks. The surfaces occur at elevations up to 50 metres higher than the main pediment surface (Figure 3.17). These isolated high pediment remnants stand increasingly higher in the relief with increasing distance from the scarp (radial 8 *in* Figure 3.8; Figures 3.18 & 3.19). Their summits are planed across steeply dipping shales and minor limestones and are covered by 1.0-1.5 metres of pebbles and cobbles, predominantly of quartzite and limestone, both derived from the backing upland.

The highest and most extensive remnants appear to be elements of a pediment fan the apex of which occurs where Bundulla Creek now emerges from the upland (16 *in* Figure 3.20, Table 3.1), suggesting that an ancestral Bundulla Creek was responsible for the planation, and later the dissection, of this part of the high pediment. Streams of the Walkandi Creek system have also cut into it from the west and south. The remnants of this highest surface stand 290-340 metres above present sea level and occur 800-1900 metres from the upland. The slope gradient is  $2^{\circ}52'$  and the surface can be projected back to a bevel on the upland front marking the former hill-plain junction at about 390 metres above present sea level (Figure 3.18).

Several other isolated hills with bevelled upper surfaces stand above the level of the main pediment. They have been interpreted as high pediment remnants which were probably eroded by Walkandi Creek and an unnamed tributary stream to the north (14 & 15 in Figure 3.20, Table 3.1). The summits of these remnants lie 310-330 metres above present sea level and occur up to 1 kilometre from the upland. Overall the thinly covered surface slopes gently at  $1^{\circ}21'$  down to the west. Parts of its upper slopes meet the backing scarp in a piedmont angle at about 340-350 metres above present sea level. Several rounded, but lower, strike ridges and hills, without an alluvial cover, appear to have resulted from the dissection of the pediment and differential erosion of the underlying Cambrian sequence (Figure 3.21).

(ii) Bunyeroo 'High' Pediment

South of Bunyeroo Creek, remnants of a covered pediment fan stand some 40-50 metres higher than the present stream beds (Figure 3.22). The level of the proximal slopes of the Bunyeroo pediment can be traced north into that of the main pediment on either side of Brachina Creek and south into that of the dissected summit surface of the hills east of Edeowie H.S., but the distal slopes, some 2 kilometres from the upland, stand higher in the landscape than those of the main pediment (Figure 3.1). The surface is cut across both folded shale and limestone and (?)Tertiary orthoquartzites (Dalgarno & Johnson, 1966). The outcrops of orthoquartzite buttress the distal slopes (Figures 3.22 & 3.23), and the surface gradient of  $1.5^{\circ}$ - $2.0^{\circ}$  down to the west is gentler than that of the main pediment elsewhere. The surface can be linked in projection to the bevelled spurs of the front limestone ridge of the Heysen Range (Figure 3.7; radials 16 & 17 in Figure 3.8). The overall slope of the ridge-line surface, from the vicinity of Mount Hayward in the north to the mouth of Bunyeroo Gorge, suggests that this was the master stream, and that the Brachina Creek drainage developed later. The upland gorge mouth of Brachina Creek is some 20 metres lower than that of Bunyeroo Creek.

(c) Modern Pediments

In places, modern pediments, or eroded bedrock plains of limited extent, are developing at the expense of the main covered pediment and their cover is derived from the older pediment. Brachina and Bunyeroo creeks flow westwards across the pediment apron and are incised some 30-40 metres below the level of the main pediment. They provide a local baselevel for numerous tributaries rising within the upland and on the pediment surface. For example, an unnamed stream system, which eventually flows northwest to Commodore Swamp along the edge of the Brachina Alluvial Fan, rises within the pediment apron and has undercut the southern margins of the Hayward Pediment as it erodes a modern pediment some 1.5 square kilometres (Figure 3.24). Only broad rises, east and south of the Lookout hill, remain of the higher pediment. The modern pediment is an eroded bedrock surface, inclined at  $1^{\circ}14'$ , which carries a scatter of allochthonous material, derived from the reworking of materials from the main pediment. Arguably, in time, the coarser fraction of the cover will be concentrated at the surface as a result of washing out of fines and/or the churning and sorting of material if gilgai develop. Similarly, tributaries of Bunyeroo Creek, e.g. 22 in Figure 3.20 and Table 3.1, and minor streams which, for the most part, rise on the pediment surface and dissipate on the Bunyeroo Alluvial Fan and Torrens Plain, are eroding a modern pediment (Figures 3.1 & 3.25).

South of White Cliff Creek streams incised into the main pediment have eroded flood plains and left behind plains of lateral corrasion at levels intermediate between the main pediment and the modern flood plain and exposed several minor strike ridges (Figure 3.26a & b). A scatter of small, platy detritus covers the bedrock of the flood plain, which is marked by a very fine, shallow drainage pattern of rills (Figure 3.26c). Coarse alluvial gravels, similar to the cover of the higher erosional surfaces, are carried by minor streams incised less than one metre in the surface. Spreads of these gravels on the modern pediment surface suggest that similar streams once flowed there and eroded the surface (Figure 3.26d).

Very narrow straths, only 3-4 metres wide, have been eroded by many of the streams dissecting the main pediment in the Parachilna-Brachina section of the piedmont. They are

interpreted as incipient covered pediments. They are protected by a thin cover of alluvial gravels, but include some boulders measuring up to one metre in diameter. They do not persist very far downstream.

(d) Riverine Outwash Plains

In addition, some of the streams which initially eroded the main pediment fans are now associated with extensive fan shaped spreads of coarse, blocky alluvium inset within the pediment apron, e.g. 3, 4, 27 & 28 in Figure 3.20 and Table 3.1. The apex of each fan occurs at the point where the stream emerges from the upland. In appearance they resemble glacial outwash fans and have been called 'riverine outwash plains'. They are virtually flat flood plains (Figure 3.27), characterised by coarse sandstone and limestone detritus deposited in bars and swales. Their longitudinal slopes, measured normal to the scarp, average  $1.9^\circ$ , and are similar to those of minor alluvial fans of the study area. Riverine outwash plains differ from alluvial fans, which are characterised by a convex-upward transverse profile, and the deposits of which include a significant proportion of argillite. Although riverine outwash plains are covered with coarse detritus, they are not comparable with pediments in two respects. Their surfaces are more gently inclined than those of the main pediment surface, the slope of which averages  $2.7^\circ$ . Relief amplitude of their surfaces is 2-3 metres, whereas those of pediments are relatively smooth.

The Edeowie riverine outwash plain (Figures 3.27 & 3.28) may be taken as a large example of such a form in the study area. There is neither borelog nor geophysical evidence as to the thickness of sediment below the surface, and it would be difficult to obtain because of the prevalence of coarse detritus, but on the available evidence the riverine outwash plain is underlain by 10 metres or less of coarse sediment, derived from the exclusively quartzitic wall of Wilpena Pound. This suggestion is based in the exposure of bedrock in bounding bluffs (Figure 3.28) and in the maximum adduced depth of scour and single-event deposition by a major river such as Brachina Creek (Figure 3.29).

## 2. Drainage Basins

The Heysen Range between Parachilna Gorge and Wilpena Pound is the backing scarp for the pediments of the Parachilna-Edeowie region. The Range comprises several ridges, of various lithologies, which together form the western limb of the regional anticlinorium of the central Flinders Ranges (Dalgarno & Johnson, 1966; Callen & Reid, 1994). The most prominent ridge is of Rawnsley Quartzite which dips generally  $25^{\circ}\text{W}$ , but steepens to  $55^{\circ}$ - $65^{\circ}\text{W}$  in the vicinity of faults. Immediately to the west, the massive Wilkawillina Limestone, dipping at  $45^{\circ}$ - $70^{\circ}\text{W}$ , forms a lower, but minor range.

The drainage basins of streams related to the pediment surfaces in this region are restricted to these formations, which are resistant to weathering and erosion because of their massive and impermeable character (Figure 3.20, Table 3.1). Relief amplitude is greatest in those drainage basins dominated by sandstone rather than limestone. The highest points in the Heysen Range are of Rawnsley Quartzite, e.g. Mount Hayward 865m, Mount Abrupt 861m, and Reggie Nob 907m.

The basins are small and rugged (Table 3.1). The largest catchment is 3.35 square kilometres in area and most are less, the average being 2.41 square kilometres. Their length, measured parallel to the trunk stream, varies from 0.8-2.5 kilometres (Figure 3.20, Table 3.1). Regression analysis shows no relationship between basin area and basin length (Appendix II: Pediments). This unexpected result may be due first to a paucity of observations with a small range of values and second to the strong control exerted by structure on the area and length of basin. The catchments are third order basins and attain the order just inside the mouth of the basin, which gives some measure of the development of the drainage network (Horton, 1945; Strahler, 1957; but see Shreve, 1966).

The streams draining these catchments, together with streams originating below the upland scarp on the pediments themselves, have incised below the pediment surface. Most simply flow normal to the scarp and parallel to one another, but some have flowed to the topographic lows between pediment fans and others are tributary to the master streams of



the region, which have breached the western rampart of the upland and are associated with major alluvial fans.

Riverine outwash plains are associated with streams draining catchments which are confined to the broader quartzite outcrops of the Heysen Range and Wilpena Pound. Their basins are larger than those associated with streams eroding pediments, but they have not yet extended into argillaceous sediments, which give rise to minor alluvial fans (see Chapter Four). There are some specific examples. Edeowie Creek and the unnamed stream immediately to the north (27 & 28 in Figure 3.20) have eroded larger than usual drainage basins in Rawnsley Quartzite, but the increased supply of detritus is all blocky and coarse arenaceous material. The other catchments associated with riverine outwash plains are similarly restricted to the resistant ridges of the Heysen Range, but are only slightly larger in area than those associated with the main pediment surface (Table 3.1).

## B. WYACCA-EMEROO REGION

### 1. Pediments

Covered pediments form a narrow, discontinuous fringe to the upland in the inner zone of the western piedmont of the Wyacca-Emeroo region (Figure 3.2, Table 3.3). The surface is eroded across Proterozoic Rhynie Sandstone (or its equivalent, Emeroo Quartzite) between Thompson and Dry South creeks, but otherwise in rocks older than the Rhynie Sandstone, e.g. trachyte, siltstone, sandstone, dolomite and diapiric breccia (Dalgarno *et al.*, 1968). Strata dip east into the scarp, which is a faceted slope. The pediment cover, some 1-2 metres thick, is mostly of sandstone and some dolomite fragments and cobbles to 30cm derived from the backing upland. It affords some protection from further erosion for the weathered bedrock surface.

The piedmont angle is developed in uniform lithology, albeit the less resistant shales, a situation similar to that found in the Tent Hills (Figure 1.1), where the strata are virtually flat-lying with a quartzite caprock overlying purple shales (Twidale, 1967a; Twidale *et al.*,

1970). Concentration of moisture and weathering of the shales at the scarp foot is manifested in the presence of a kaolinised zone and in the spasmodic occurrence of silcrete (or orthoquartzite, as in the study area, e.g. in the scarp foot zone near Thompson and South creeks). Erosion of the weathered zone, together with volume loss on weathering, produces scarp foot valleys and induces regrading of the backing scarp to the maximum inclination commensurate with stability.

The pediment is essentially intact and contiguous with the backing upland in the piedmonts of the Wyacca and Emeroo ranges proper. The surface is considerably dissected between Wilkatana North and Deep creeks (Figure 3.2) and stands some 30-50 metres above the level of the adjacent alluvial fans. The length of the pediment surface, 100-650 metres, is much less than its counterpart in the Parachilna-Edeowie region, where pediment length is measured in kilometres. Here, also, faults truncate the toeslopes of the surface. The pediment remnants slope down from the backing upland at  $3^{\circ}$ - $6^{\circ}$ , for only the steeply inclined, upper slopes of the surface survive. Indeed, no pediment remnants occur in the vicinity of Wilkatana North Creek where the fault is exposed in the mouth of the gorge (Williams, 1973; see also Figure 1.7), nor immediately south of Deep Creek, where the marginal fault has truncated the dissected spurs of the scarp (Figure 3.30).

#### (a) Pediments of the Wyacca and Emeroo Ranges

The pediment surfaces at the foot of the Wyacca and of the Emeroo ranges proper appear to be quite narrow: bedrock exposures in creeks incised into the surface are less than 200 metres from the scarp foot. The drainage network of the inner piedmont zone outlines a series of fan shaped forms interpreted as pediment cover at least within 200 metres of the scarp (Figure 3.31a & b). The surfaces slope at some  $3^{\circ}$ - $4^{\circ}$ . They are covered by at least 2 metres of alluvium and colluvium, which thickens downslope as it merges with the alluvial basin deposits of the Port Augusta Corridor. Bars of detritus, comparable to those found in channels of major streams in the region, are included in the alluvial cover. To the west of the Wyacca Range, about one kilometre from the scarp, the alluvial surface slopes at only  $2^{\circ}$  and is underlain by about 50 metres of sediment, which presumably buries the

lower slopes of the pediment (Figures 1.4 & 1.8b, Table 1.1), and yet there is no morphological evidence to indicate the position of the fault, apart from the scarp itself.

#### (b) Pediment Remnants of the Central Section

Remnants of the covered pediment surface are preserved at the margins of the upland in interfan areas of a series of major alluvial fans (see Chapter Four) in that part of the Wyacca-Emeroo piedmont between Wilkatana North and Deep creeks (Figure 3.2, Table 3.3). The erosional surface is considerably dissected by tributaries to interfan stream systems, e.g. Connolly Creek, which rise on the escarpment and are graded to sea level.

Immediately north of Depot Creek covered erosional surfaces, inclined at  $3^\circ$  and  $6^\circ$  and no more than 100-200 metres long, are eroded across the footslopes of several narrow spurs (Figure 3.32). Pediment remnants occur in the interfan areas between Depot and Thompson, Thompson and Dry South creeks and between South and Deep creeks. They are connected to the backing scarp in a piedmont angle, slope variously at  $2^\circ$ - $6^\circ$  and measure 250-650 metres in length. At several sites remnants of the surface are preserved because recurring resistant strata, dipping eastwards into the scarp, form ramparts protecting the planed surfaces behind from erosion (Figure 3.33). In places, the pediment surface is represented by shoulders and breaks of slope marked by patches of whitish weathered bedrock on the upland escarpment, particularly above the gorge mouths of Wilkatana North, South and Deep creeks (Figure 3.34), and in the interfan area between Wilkatana South and Depot creeks (Figure 3.2).

Pediment embayments have been eroded by some of the streams which have also deposited the major alluvial fans in the Wyacca-Emeroo piedmont (*cf.* initiation of pediment passes; Howard, 1942). The largest, e.g. those associated with South and Deep creeks, are coincident with fracture zones. Eroded across steeply dipping bedrock, the pediments slope  $4^\circ$ - $6^\circ$  down from the upland within the embayments and thence grade to gentler  $3^\circ$ - $4^\circ$  surfaces (Figure 3.35). They are covered with 2-3 metres of alluvium. Alluvial fan

deposits onlap and bury the toe of the pediments, although clearly the erosional surface stands at a higher level than that of the apex slopes of the alluvial fans (Figure 3.36).

## 2. Drainage Basins

The front ridge of the upland in this region is mostly of Rhynie Sandstone, or its equivalent, the Emeroo Quartzite. The Wyacca and Emeroo ranges are coincident with those sectors where the outcrop attains maximum width. In between these named ridges, which coincide with synclinal structures plunging north and south respectively, the outcrop narrows, is fractured (Figure 1.6c), and has been subjected to considerable weathering and erosion. In this sector Skillogalee Dolomite forms the scarp.

Drainage basins associated with streams responsible for the erosion of the pediments, are confined to resistant quartzite, sandstone and dolomite (Table 3.3). The drainage divide stands some 450-550 metres above present sea level and relief amplitude is of the order of 350 metres. The minor streams, which drain the quartzite and sandstone of the Wyacca and Emeroo ranges proper and flow across the pediments, have small catchments, averaging less than 1 square kilometre (Figure 3.37a, Table 3.4). Second order streams drain these basins and debouch from the upland every 450-600 metres. On the other hand, in the dolomite of the central section, numerous second order streams, which are associated with the areas of pediment remnants, have very small drainage basins, averaging less than 0.5 square kilometre (Figure 3.37b, Table 3.4). They emerge from the upland every 300-350 metres.

## III. ORIGIN OF THE PEDIMENTS

In the study area the pediment apron lies between the scarp foot and proven and probable fault lines. Some might cite the region as a *prima facie* example of scarp retreat and pedimentation (King, 1949, 1953, 1966, 1968; Blissenbach, 1954; Bull, 1977); the upland margin has, indeed, been referred to as a fault-line scarp (Wellman & Greenhalgh, 1988). However, the contrasting lithology between hill and plain and etching out of the scarp foot

Table 3.3 Pediments of the Wyacca-Emeroo region.

FEATURE NAME/LOCATION	DRAINAGE BASIN			PEDIMENT					
	AREA km <sup>2</sup>	LENGTH m	H/P m	BEDROCK	OCCURRENCE	BEDROCK	COVER m	LENGTH m	SLOPE pediment (scarp) <sup>o</sup>
Wyacca Ra piedmont	0.54	800	630	Qu (+D in 22,23)	covered pediment alluvial apron	siltstone	2	<200	3-4
Wilkatana North interfan Wilkatana South	0.23	600	540	Qu	shoulder, wth'd patches	volcanics			
Wilkatana South interfan Depot	0.27	500	480	Qu	shoulder, wth'd patches, spurs, contiguous	volcanics	2-3	100-200	3-6 (16-19)
Depot interfan Thompson	0.21	500	430	Qu	remnants, contiguous rampart, siliceous outcrop, faulted area	volcanics wth'd Qu	2	250	3 (22)
Thompson interfan Dry South	0.27	700	520	Qu (+D+Sh in 8,11)	remnants, contiguous	wth'd Qu	2	350-500	3-6
South: pediment embayment					pediment embayment faulted zone	wth'd Qu	2-3	250	4-6
South interfan Deep	0.21	400	470	Qu (+D in 6)	remnants, contiguous structural rampart, siliceous outcrop	diapiric breccia	1-2	650	2-5
Deep: pediment embayment					pediment embayment faulted zone	wth'd Qu	2	600	3
Emeroo Ra piedmont	0.46	900	440	Qu (+SiSt in 13)	truncated spurs covered pediment alluvial apron	diapiric breccia conglomerate	2 2	250 <200	6-9 4 (18-20)

Table 3.4 Drainage basins other than those related to major alluvial fans: Wyacca-Emeroo region.

AREA km <sup>2</sup>	H/P m	P	AREA km <sup>2</sup>	H/P m	P	AREA km <sup>2</sup>	H/P m	P	AREA km <sup>2</sup>	H/P m	P
<b>WYACCA RANGE</b>			<b>WILKATANA NORTH WILKATANA SOUTH INTERFAN</b>			<b>DEPOT THOMPSON INTERFAN</b>			<b>EMEROO RANGE</b>		
1	0.54		1	0.21	530	1	0.18	450	1	0.12	P
2	0.51	370	2	0.14		2	0.24	430 P	2	0.09	410 P
3	0.43		3	0.27	530	3	0.25	430 P	3	0.27	450 P
4	0.61	400	4	0.32		4	0.24	430 P	4	0.26	P
5	0.32		5	0.19	550	5	0.15	400	5	0.29	480 P
6	0.42	450	6	0.24	550	6	0.18	340	6	0.28	520 P
7	0.42	530							7	0.38	
8	0.84	580	mean	0.23km <sup>2</sup>		mean	0.21km <sup>2</sup>		8	0.33	
9	1.07								9	0.44	540
10	0.27	605	<b>WILKATANA SOUTH DEPOT INTERFAN</b>			<b>THOMPSON DRY SOUTH INTERFAN</b>			10	0.41	
11	0.54		1	0.15	550 P	1	0.15	400 P	11	0.43	
12	0.53		2	0.10		2	0.20	400 P	12	1.00	540
13	0.89	657	3	0.13	510	3	0.18	400 P	13	2.41	500
14	0.52		4	0.16		4	0.13	400 P	14	0.20	
15	0.38	630	5	0.25		5	0.16		15	0.66	450
16	0.40		6	0.26	680	6	0.21	450	16	0.69	
17	0.27	630	7	0.38	700	7	0.14	470 P	17	0.33	400
18	0.26		8	0.25		8	0.74	540 P	18	0.49	
19	0.47		9	0.55	650	9	0.17	530 P	19	0.42	330
20	0.32	650 P	10	0.35	570	10	0.19	530 P	20	0.19	
21	0.24	640 P	11	0.29	510	11	0.68	670 P	21	0.20	
22	1.78	570	12	0.50					22	0.11	270
23	1.37	670	13	0.26	500	mean	0.27km <sup>2</sup>		mean	0.46km <sup>2</sup>	
24	0.45	670 P	14	0.34							
25	0.30	P	15	0.26	520	<b>SOUTH-DEEP INTERFAN</b>					
26	0.42	640 P	16	0.25	530 P	1	0.20	390			
27	0.25	P	17	0.20	470 P	2	0.22	420			
28	0.24	600 P	18	0.16	450 P	3	0.10				
mean	0.54km <sup>2</sup>		mean	0.27km <sup>2</sup>		4	0.15	450 P			
						5	0.08	P			
						6	0.50	470 P			
						7	0.21	500 P			
						8	0.43	460 P			
						mean	0.21km <sup>2</sup>				

Key: Table

AREA Drainage basin area (km<sup>2</sup>)

H/P Highest point in catchment (metres above present sea level)

P Covered pediment remnant

N.B. Covered pediment occurs in piedmont of Wyacca and Emeroo ranges, but indistinguishable from sediments of alluvial apron.

zone, together with the nature of the pediment cover, obviously laid down by laterally corradating streams, must be regarded as crucial for the widespread planation which has taken place. It is probable that the full extent of the pediment surface has not survived (Appendix II: Pediments) and the toeslopes of the surfaces occur on the downfaulted blocks beneath alluvial fan and lacustrine deposits.

The covered pediments of the study area are typified by those fronting the Heysen Range. They are formed by the simultaneous lateral planation and deposition by divaricating streams (Blackwelder, 1931; Twidale, 1981). They erode a fairly smooth surface in weak bedrock and simultaneously cover it with point bar deposits derived, for the most part, from the upland. Erosion of the surface is greater where adjacent systems overlap. This suggestion finds support in the plan form of pediment fans, in the provenance of the detrital cover, some components of which (Wilkawillina Limestone) are distinctive and could only have been derived from the front range, and in comparisons of the calibre and character of detritus to modern stream loads. Covered pediments form during floods and as the major elements of the distributary network incise in response to falling river levels, covered pediments are inherently dissected (Mackin, 1937; Gilluly, 1937; Cooke *et al.*, 1993) and the pediment surfaces are cut at lower and lower levels. They occur in flights or storeys within the area of high pediment remnants east of Commodore Swamp, as lower parts of the main pediment south of White Cliff Creek and as straths within the channels of minor streams dissecting the main pediment (Figure 3.1). Whether such levels represent distinct periods of pediment development over time, or continuous pedimentation (Mackin, 1937; Twidale, 1987), cannot be determined, except to observe that three elevational zones of pediment levels occur in the study area, viz. high, main and modern, and that recent incision in response to negative baselevel shifts has occurred (see Chapter One).

Abandoned stream channels remain on the undissected parts of the pediments and are readily recognised, but they tend to be choked by coarse debris deposited as the river waters seep into the subsurface in response to lowering water tables. The cover of transported detritus becomes more concentrated as fines are evacuated by wash. The pediment cover, in places, and particularly close to drainage lines, is cemented by travertine and, in some

degree, by calcrete. It protects the pediment surfaces and allows them to persist in the landscape; hence the high level remnants, which stand above the main pediment and which correlate with prominent bevels preserved high on the front scarp of the Ranges adjacent to the Brachina and Bunyeroo creeks, must be of considerable antiquity. Locally, erosion of the pediment is restricted by bedrock made more resistant by virtue of rock type or structural differences, e.g. the orthoquartzite of the Bunyeroo 'high' pediment and the structural highs forming ramparts to protect pediment surfaces in the Wyacca-Emeroo region (*cf.* Bryan & McCann, 1936; Gilluly, 1937; Twidale, 1983b). Moreover, the position of the high pediment area, approximately on the divide between Brachina and Parachilna creeks, contributes to its survival. Elsewhere within the Flinders Ranges, remnants of former valley floors are preserved near to drainage divides, e.g. north of the Chace Range, and in the upper parts of the Bunyeroo, Kanyaka, Arden and Mern Merna valleys. Covered pediments are reduced in area by scarp retreat from the lines of incised drainage. Eventually, the cover is evacuated as is demonstrated by some of the high level remnants in the Bundulla-Walkandi area (Figure 3.21), where the hills have been stripped of their coarse exotic cover to stand as rock pediments in siltstone which are not, however, of two-stage or etch type.

Whether covered pediments are forming at the present time is uncertain, but the initial stage of their development may be represented by the riverine outwash plains that occur at several sites in the study area. Riverine outwash plains may be interpreted as thin, immature alluvial fans and this will be considered in Chapter Four when minor alluvial fans are discussed. However, the preferred interpretation is that the riverine outwash plains represent the initial stage of the development of modern covered pediments. It is suggested that if stream incision associated with floods were to cause dissection of the riverine outwash plain, such that the presumed underlying country rock is exposed beneath the alluvial cover, fines will be washed from the cover and the coarse fraction concentrated. Dissected covered pediments comparable to those of the main pediment of the Heysen piedmont would develop.



#### IV. AGE OF THE PEDIMENTS

Erosion of the pediments followed the renewed uplift of the Flinders Ranges and downfaulting of the Pirie-Torrens Basin towards the end of the Cretaceous and the beginning of the Cainozoic. The existence of Eocene and possible Miocene lacustrine sediments beneath the present bed of Lake Torrens and the Torrens Plain to within 5 kilometres of the upland margin suggest baselevel for those laterally corradating streams was closer to the upland than now. On stratigraphic evidence, therefore, the formation of pediments probably postdates the Miocene. Moreover, this limit for the age of pediment formation is confirmed if the crystalline silcrete and orthoquartzite found in association with the main pediment surface is dated as of Middle Tertiary age (see Chapter One).

Absolute dating was proposed for the flight of pediment levels, which occur west of Mount Hayward, because their relative age relations are clear. Unfortunately, testing for rock varnish on quartzite cobbles taken from the various levels was unsuccessful (C. G. Harrington, pers. comm., 1993). Dating of samples, taken from the pediment cover and from the related bevelled ridge behind, using *in situ* cosmogenic isotopes has been tried, but without result. A new attempt in collaboration with Australian Nuclear Science and Technology Organization is in train.

#### V. CONCLUDING STATEMENT

The pediments of the study area are evidently due to erosion by laterally corradating streams. Higher, older pediment remnants and contemporary erosional surfaces occur in favourable structural and topographical settings within the main pediment apron fringing the Flinders Ranges. Upon leaving the adjacent upland of relatively resistant strata, streams divaricate across weaker rock effecting planation and shallow dissection and leave behind up to two metres of bedload material to cover and protect the pediment. Concentration of the coarser fraction of the alluvial cover on these pediment fans over time, redistribution by wash and gravity of the cover materials and probably some degree of mantle-controlled planation serve to armour and smooth the surface. Its smoothness is more apparent than real, for in

detail the cut bedrock surface has a relief amplitude of at least one metre. The length of the pediment fringing the upland has been determined in places by faults delineating the western margins of the Flinders Ranges. In any given sector of the piedmont the stratigraphic relationships of the various elevational zones within the pediment apron are clear, as is the relative age of pediments and alluvial fans. The absolute dating of the pediment surfaces is, however, problematic.

## CHAPTER FOUR

### ALLUVIAL FANS IN THE WESTERN PIEDMONT OF THE FLINDERS RANGES

#### I. INTRODUCTION

Alluvial fans dominate the western piedmont of the Flinders Ranges. They occupy some 95% of the piedmont zone in the Wyacca-Emeroo region, and, even where pediment surfaces are well and widely developed in the Parachilna-Edeowie region, alluvial fans account for about 80% of the total piedmont area (Figure 4.1).

The major alluvial fans of the study area are backed by uplands of folded sedimentary sequences, which stand at relatively high elevations above the piedmont zone compared with those upland sectors which give rise to the pediments (Figure 4.2). They are associated with drainage basins which are extensive and penetrate deeply into, and well beyond the western ramparts of, the Flinders Ranges and into terranes of argillaceous sediment (Table 4.1). Thus the supply of sediment necessary for the formation of large alluvial fans is ensured by the lithology, size and relief amplitude of their drainage basins.

Many potential paths for streams to breach the resistant western ridges of the Flinders Ranges are provided by faults, zones of closely spaced fractures and lithological junctions (see Figures 1.4 & 1.6). Not all these zones of structural weakness have been exploited, but in a regional sense, those that have been are regularly spaced: between Parachilna and Willochra creeks, master streams debouch from the upland every 24-28 kilometres to deposit alluvial fans each of which covers more than 75 square kilometres in area (Figure 4.3, Table 4.2). Drainage integration has been achieved (see e.g. Willgoose *et al.*, 1991) and their catchments extend to the divide between the Lake Torrens and Lake Frome drainages of the Flinders Ranges. The Willochra Creek drains an intermontane basin, which extends some 90 kilometres to the south. South of the Willochra Creek outlet streams drain smaller catchments, which are restricted to the Wyacca-Emeroo ranges.

Table 4.1: Major alluvial fans in the western piedmont of the Flinders Ranges.

STREAM		DRAINAGE BASIN					PARACHILNA-EDEOWIE REGION		
NAME	AREA (A)	LGTH	H/P	H	R/R	STREAM ORDER	SEGM'T ORDER	BASIN/FAN RATIO	
	km <sup>2</sup>	km	m	m	H/√A	(ANS)	(RLS)		
PARACHILNA	599.00	21.50	817	567	.023	7	-	1:0.389	
BRACHINA	350.00	19.00	865	615	.033	5	-	1:0.457	
BUNYEROO	127.00	13.00	861	561	.049	5	-	1:0.945	
STREAM		ALLUVIAL FAN					PARACHILNA-EDEOWIE REGION		
NAME	AREA	LGTH	SURFACE ELEVATION	GRADIENT FAN		GRADIENT STREAM	FANHEAD TRENCH		
	km <sup>2</sup>	km	m	Field	Map	Field	m		
PARACHILNA	233.0	17.5	(210-110)	0.5°	0°19'	0.5°	10		
BRACHINA	160.0	19.0	(200-90)	1°-1.5°	0°22'	0.5°	8		
BUNYEROO	120.0	17.0	(200-90)	1°-0.5°	0°19'	0.5°	6		
STREAM		DRAINAGE BASIN					WYACCA-EMEROO REGION		
NAME	AREA (A)	LGTH	H/P	H	R/R	STREAM ORDER	SEGM'T ORDER	BASIN/FAN RATIO	
	km <sup>2</sup>	km	m	m	H/√A	(ANS)	(RLS)		
[Wilk N	1.78	1.50	610	350	.262	3	30	-]	
[Wilk S	1.37	1.50	670	380	.325	3	13	-]	
WILKATANA NTH	16.41	4.50	844	574	.142	5	125	1:2.163	
WILKATANA STH	6.38	3.50	818	538	.213	4	43	1:2.429	
DEPOT	39.51	10.00	844	644	.102	5	236	1:1.126	
THOMPSON	13.05	4.00	670	440	.122	5	166	1:1.111	
DRY SOUTH	7.14	4.25	847	597	.223	4	77	1:2.241	
SOUTH	11.58	4.75	830	600	.176	5	129	1:1.166	
DEEP	11.73	4.00	820	630	.184	5	95	1:1.151	
[Ukat	2.41	2.75	525	385	.248	3	21	1:1.244]	
[Emeroo N	0.66	1.00	445	315	.388	3	4	-]	
[Emeroo S	0.69	1.00	440	300	.361	3	5	-]	
MUNDALLIO	32.10	10.00	769	619	.109	5	311	1:0.997	
STREAM		ALLUVIAL FAN					WYACCA-EMEROO REGION		
NAME	AREA	LGTH	SURFACE ELEVATION	GRADIENT FAN		GRADIENT STREAM	FANHEAD TRENCH		
	km <sup>2</sup>	km	m	Field	Map	Field	m		
[Wilk N	-	3.25	(280-80)	-	-	-	-]		
[Wilk S	-	2.50	(290-120)	-	-	-	-]		
WILKATANA N	35.5	7.00	(260-60)	2°	1°38'	2°	10		
WILKATANA S	15.5	6.50	(280-70)	-	1°51'	2°	4		
DEPOT	44.5	9.00	(200-50)	1.5°-2°	0°57'	2°	6		
THOMPSON	14.5	8.50	(230-50)	2°	1°12'	2°	4		
DRY SOUTH	16.0	7.00	(230-60)	2°	1°38'	2°	6		
SOUTH	13.5	6.50	(230-50)	2°-1.5°	1°33'	2°	8		
DEEP	13.5	4.50	(190-30)	2°	2°20'	2°	3		
[Ukat	3.0	2.50	(140-30)	3°	2°38'	3°	-]		
[Emeroo N	-	1.13	(130-60)	4°	-	4°	-]		
[Emeroo S	-	1.50	(140-60)	4°	-	4°	-]		
MUNDALLIO	32.0	8.00	(150-30)	2°	0°51'	2°	6		

Table 4.2: Spacing of streams emerging from the upland and depositing major alluvial fans in the western piedmont of the Flinders Ranges

STREAM NAME	SPACING OF STREAMS		
	NAMED UPLAND STRUCTURES	DISTANCE BETWEEN MASTER STREAMS (km)	GORGE MOUTHS *SELECTED STREAMS (km)
	Heysen Range		
PARACHILNA		0	0
BRACHINA		24	24
BUNYEROO		7.5	
	Wilpena Pound		
Aliena		13.5	
	Mt. Burns		
MORALANA		4	25
	Mern Merna Dome		
HOOKINA		28	28
	Mt. Eyre		
NEUROODLA		15	
WILLOCHRA		13	28
	Wyacca Range		
WILKATANA NORTH		24	24
DEPOT		13	13
DEEP		13	13
	Emeroo Range		
MUNDALLIO		13	13

\*SELECTED indicates streams associated with major alluvial fans

They emerge from the upland at irregular intervals and have deposited alluvial fans which vary from 13-45 square kilometres in area (Table 4.3). The largest of these are associated with those streams closest to achieving drainage integration and escaping the control exerted by the structures underlying the Wyacca and Emeroo ranges.

The major alluvial fans and associated drainage basins of the Parachilna-Edeowie and Wyacca-Emeroo sectors of the western piedmont of the Flinders Ranges are described in the following regional accounts. They differ in areal extent, surface morphology and slope, but there is a good statistical correlation between each alluvial fan and its catchment (Appendix II: Major Alluvial Fans).

## II. REGIONAL ACCOUNTS

### A. PARACHILNA-EDEOWIE REGION

#### 1. General Statement

Much of this sector is backed by a broad upland coincident with outcrops of massive quartzite and sandstone (Figure 1.4). No major streams breach this rampart and pediments are prominent in the piedmont (see Chapter Three), although the riverine outwash plains and minor alluvial fans inset within the pediment apron are important to any consideration of the development of the landform assemblages in the study area. Major alluvial fans are developed in association with the Parachilna, Brachina and Bunyeroo creeks, which have eroded through the Heysen Range where the resistant strata thin and faults provide zones of structural weakness (Figure 1.4). Those streams have extended eastwards into the upland and drain large areas of predominantly argillaceous sediments.

Table 4.3 Spacing of streams emerging from the Wyacca-Emeroo ranges and depositing alluvial fans

SPACING OF STREAMS: WYACCA-EMEROO REGION			
STREAM NAME	NAMED UPLAND STRUCTURES	DISTANCE BETWEEN GORGE MOUTHS	
		MASTER STREAMS (km)	*SELECTED STREAMS (km)
WILLOCHRA		0	0
	Wyacca Range		
WILKATANA NORTH		24.00	24.00
WILKATANA SOUTH		3.50	
DEPOT		9.50	13.00
THOMPSON		3.50	
DRY SOUTH		3.50	
SOUTH		1.50	
DEEP		4.75	
	Emeroo Range		
MUNDALLIO		12.50	25.75

\*SELECTED indicates streams associated with major alluvial fans >32 km<sup>2</sup>

## 2. Parachilna Alluvial Fan

Parachilna Creek emerges from the uplands by way of the Parachilna Gorge, where sections of the ridges of Heysen Range are displaced by faulting (Dalgarno & Johnson, 1966; Callen & Reid, 1994).

### (a) Dimensions

The apex of the Parachilna Alluvial Fan lies at the mouth of the Gorge (Figures 3.1 & 4.4). The fan covers an area of 233 square kilometres and has a radial length of 17.5 kilometres. There are no topographic constraints and the fan spreads through an arc of 110°. Swamps, their drainage impeded by the deposits of the alluvial fan itself and the sands of the dunefield, and stream channels deflected to northwest and south outline the eastern margins of the fan. The fan merges downslope with the alluvium of the Torrens Plain, which extends another 15-20 kilometres to the eastern shore of Lake Torrens.

### (b) Deposits

Parachilna Creek has undercut the margin of its own deposits near the fanhead, exposing some 5-10 metres of alluvium. No debris flows have been identified in the sequence, although they commonly contribute material to the upper parts of alluvial fans. The proximity of the fanhead to the escarpment argues for their likely existence within the fluvial deposits, but the backing ridge is of limestone and the streams of rock are typical of the quartzite outcrops. Three kilometres from the fan apex drilling (Anonymous, 1982) has revealed abundant coarse alluvial gravels to a depth of some 60 metres. They are succeeded below by at least 90 metres of Cainozoic sediments, which include clay, silt, and fine sand (CO-2 in Figure 1.9). Weathered Cambrian bedrock was encountered below the Parachilna Alluvial Fan in the Santos Motpena No.1 bore at 214 metres, sunk some 20 kilometres from the upland near the margin of the Fan (Figures 1.4 & 1.8, Table 1.1). Nowhere else, however, has the base of the Fan been defined, but on the evidence of logged cores conglomerates are at least 60 metres thick.



### (c) Slope and Surface

The slope of the Parachilna Alluvial Fan, measured along the axis, is  $0^{\circ}19'$ , and is inversely proportional to fan area and fan radius (2 in Figure 3.8, Table 4.1). Its gentle inclination reflects the abundant supply of fine-grained sediment derived from its drainage basin (see below). The gradient of the axis is relatively steeper than the flanking slopes (Figure 4.5), which suggests that the fan segments on either side of the Parachilna Alluvial Fan have more recently received accessions of sediment. At present from its point of debouchment Parachilna Creek flows in a broad, braided channel southwards along the Fan perimeter to Commodore Swamp, rather than westward along the axis slope. In flood, however, some of its flow is diverted to run southwest across the surface of the fan in Cottage Creek and various other, minor, distributary channels. The different drainage texture domains (Figures 4.4 & 4.6, Appendix 1) displayed on the surface of the Fan demonstrate that it has been built segment by segment and that different fan segments are active at any one time. For example, on the proximal slopes between the axis of the Fan and Parachilna Creek local dissection of a broad spread of coarse deposits has produced a relief amplitude of 1-2 metres and supports a relatively dense vegetation of bushes and shrubs, whereas the northern half of the fan has very few active channels and has a vegetation association which includes very few, low bushes (Figure 4.6). Variations in soil and vegetation indicating fan segments and secondary fan deposits are made clear by the false colours of satellite imagery (Figure 4.7).

### 3. Drainage Basin

Parachilna Creek and its many tributaries drain an area of some 600 square kilometres, which is more than double that of the Alluvial Fan. The drainage basin is 21.5 kilometres long, measured parallel to the trunk stream. Considerable weathering and erosion of the basin is reflected in the significant relief amplitude but low ruggedness figures (Table 4.1). Most of the basin lies below 600 metres, although many high points stand above 700 metres above present sea level. The lithology of the catchment consists predominantly of shale and siltstone exposed in the Blinman Dome. An annular drainage pattern has developed on

the dome structure and associated relief, which contributes to the almost circular plan form of the basin (Figure 4.3), a shape which may indicate maturity of the drainage network (Schumm, 1956; Morisawa, 1968; Gregory & Walling, 1973).

#### 4. Brachina-Bunyeroo Alluvial Fan

##### (a) Dimensions

Brachina and Bunyeroo creeks debouch from the ranges only 7.5 kilometres apart, compared with the 24-28 kilometres between other master streams in the region (Table 4.2). Each has deposited an alluvial fan but on leaving the upland each stream is incised in the pediment apron for 3-4 kilometres, so that the apex of each alluvial fan is that distance from the gorge mouth (Table 4.4). Because of the close proximity of the two streams their alluvial deposits have coalesced to form the Brachina-Bunyeroo Alluvial Fan, with a combined area of about 280 square kilometres (Figure 3.1, Table 4.1). The development of the Fan south of Bunyeroo Creek is limited by the Mount Burns upland but to the north it is separated from the lower slopes of the Parachilna Alluvial Fan by the Commodore Swamp. A sheet of aeolian sand, which laps on to the toeslopes of the Fan, makes it impossible to determine the distal extent of the alluvial fan deposit without extensive drilling.

##### (b) Deposits

The Fan has apparently been built entirely of fluvial deposits; there is no evidence of debris flow deposition, and it is unlikely that such materials are incorporated in the fan deposits because of the distance of the fan apices from the upland. Lenses of coarse alluvial material are exposed in the walls of the incised stream systems and the main channels have a very coarse bedload, including boulders up to 2 metres across. However, the bulk of the alluvial fan deposit consists of clay and sand (Figure 4.8). Borelogs and seismic surveys (Figure 1.4, CO-4 & 5 in Figure 1.9, Table 1.1) indicate that about 60 metres of Quaternary alluvium overlies some 300-380 metres of fluvial and lacustrine Tertiary

Table 4.4 (1 of 2) Drainage Basins, Pediments and Alluvial Fans: Parachilna-Edeowie region, Parachilna-Brachina sector of Heysen Range piedmont.

STREAM		DRAINAGE BASIN					PEDIMENT					ALLUVIAL FAN						
CODE	NAME	FREQUENCY km	AREA km <sup>2</sup>	BEDROCK % L/S S/S		LGTH km	H/P m	H m	R/R H/√A	LEVEL	SHAPE	LENGTH km	SLOPE x°	APEX from scarp km	SIZE	LENGTH km	SLOPE x°	
1	PARACHILNA	0	599.00	-	5	95	21.5	817	567	.023	-	-	-	-	0.0	major	17.5	0.3
2	Parachilna tributaries	-	<1	50	50	0	1.3	622	-	-	main	contiguous	1.2	2.9	-	-	-	-
3	Parachilna tributary	4.5	2.68	63	37	0	1.8	792	402	.246	-	-	-	-	0.0	r/o p	2.0	2.3
4	Parachilna tributary	1.0	2.81	67	33	0	1.8	784	534	.318	-	-	-	-	0.0	r/o p	2.2	2.2
5	Five Mile	1.8	9.13	11	44	50	3.8	817	517	.171	-	-	-	-	0.0	minor	3.6	1.5
6	Barregowa North &	0.8	1.15	67	33	0	1.5	624	324	.302	main	dissected	2.0	2.7				
7	Barregowa South	0.7	3.41	28	43	29	2.0	697	397	.215		fan			1.2	minor	2.4	1.9
8	Tea Cosy	1.3	4.61	22	45	33	3.3	750	450	.210	-	-	-	-	0.8	minor	3.2	1.8
9	Warekila & tributaries	-	<1	55	45	0	2.0	801	501	-	main	dissected	2.0	-	-	-	-	-
10	Bathtub	3.6	5.04	10	40	50	3.8	804	504	.224	main	dissected	3.2	-	0.0	minor	3.2	2.2
11	Bundulla tributary	1.2	1.02	100	0	0	1.8	608	308	.305	main	dissected	2.0	2.6	-	-	-	-
12	Bundulla tributary	1.2	1.23	100	0	0	0.8	690	290	.261	main	dissected	2.0	-	-	-	-	-
13	Bundulla	1.5	3.75	14	57	29	2.8	758	408	.211	high	few remnants	1.4	-	2.0	minor	2.4	1.7
											main	dissected	2.4					
14	Walkandi tributary	1.2	3.07	8	67	25	2.3	820	470	.268	high	few remnants	1.6	-	2.2	minor	2.0	2.1
											main	dissected	2.2					
15	Walkandi	1.2	1.56	50	50	0	2.0	865	515	.426	high	few remnants	0.8	-	?	r/o p	2.5	1.4
											main	dissected	2.2					
16	Hayward	0.6	1.52	33	67	0	2.0	865	525	.426	main	fan	2.6	2.9	-	-	-	-
17	Ilina North	1.7	2.94	58	42	0	2.3	854	534	.311	-	-	-	-	0.0	minor	1.6	2.3
18	Ilina South	1.6	2.84	67	33	0	2.5	810	540	.320	main	contiguous	0.8	-	-	-	-	-
19	BRACHINA	1.2	350.00	0	7	93	21.0	865	615	.033	main	dissected	3.6	3	2.8	major	19.0	0.3

**Key: Table 4.4**

CODE	Drainage Basins numbered 1-30 in Figure 3.20
STREAM FREQUENCY	Linear distance of gorge mouth from that to the north
BEDROCK	L/S: Wilkawillina Limestone, Cambrian, massive archaeo- cyathid limestones, dolomitic and sandy at base. S/S: mostly Pound Quartzite, upper Proterozoic member, resistant quartzite with minor shale bands over feldspathic sandstones. Sh/Si: various shales and siltstones, in part calcareous or dolomitic, Proterozoic formations including diapiric material
LENGTH	Length of drainage basin measured parallel to trunk stream
H/P	Highest Point within drainage basin
H	Height or relief amplitude is difference between highest point and altitude of hill -plain junction
RR	Relief ratio, or degree of ruggedness, as calculated by Melton (1965), i.e. Height over /Area of drainage basin.

Table 4.4 (2 of 2) Drainage Basins, Pediments and Alluvial Fans: Parachilna-Edeowie region, Brachina-Aliena sector of Heysen Range piedmont.

STREAM		DRAINAGE BASIN					PEDIMENT					ALLUVIAL FAN						
CODE	NAME	FREQUENCY km	AREA km <sup>2</sup>	BEDROCK %			LGTH km	H/P m	H m	R/R H/√A	LEVEL	SHAPE	LENGTH km	SLOPE x°	APEX from scarp km	SIZE	LENGTH km	SLOPE x°
19	BRACHINA	1.2	350.00	0	7	93	21.0	865	615	.033	main	dissected	3.6	3.0	2.8	major	19.0	0.3
20	Brachina tributary	-	<1	77	23	0	<2.0	630	400	-	main	dissected	3.6	-	-	-	-	-
21	Brachina tributary	4.6	3.35	67	33	0	2.0	628	328	.179	main	dissected fan	4.0	1.6	-	-	-	-
22	Bunyeroo tributary	1.5	2.44	80	20	0	1.5	605	305	.195	main	dissected	3.6	-	-	-	-	-
23	BUNYEROO	2.2	127.00	0	15	85	13.0	861	561	.049	'high' main	part fan dissected	2.4 4.0	2.0 3.0	4.0	major	17.0	0.3
24	Unnamed	2.6	1.98	63	37	0	1.8	633	333	.237	main	dissected	2.4	-	-	-	-	-
25	Unnamed	0.3	1.21	42	58	0	1.8	633	333	.303	main	dissected	2.4	-	-	-	-	-
26	Unnamed	0.9	2.51	60	40	0	1.8	721	420	.265	main	dissected	2.4	-	-	-	-	-
27	Unnamed	1.8	4.72	36	64	0	2.5	861	560	.258	-	-	-	-	0.0	r/o p	2.2	1.7
28	Edeowie	2.6	18.92	0	100	0	4.8	1150	850	.195	main	dissected half fan	2.8	2.6	0.0	r/o p	3.2	2.1
29	Aliena tributaries	-	<1	0	100	0	-	-	-	-	-	-	-	-	-	-	-	-
30	Aliena	6.0	11.27	0	38	62	2.5	1150	750	.223	high rock main	dissected dissected	1.2 1.0 2.2	6.0 4.0 3.0	2.2	minor	6.0	1.5

sediments including lignitic Eocene material in the upper and midfan sections of the Fan (Figure 1.8a).

(c) Slope and Surface

The Brachina-Bunyerroo Fan has a gradient of less than  $0.25^\circ$ . Such a gentle slope is usual for an extensive alluvial fan related to a large catchment of readily eroded sediment (Bull, 1962a, 1964b; Denny, 1965; Hooke, 1968). Brachina Creek divides into two braided stream systems, Brachina Creek and Brachina Overflow, which are intrenched some 10 metres into the alluvial fan deposits near the fanhead (Figure 4.9). Bunyerroo Creek is similarly incised in its alluvial deposits but flows along the axis of its part of the Fan. These braided streams are intrenched at least 2 metres throughout the length of the fan deposits. In addition to these major streams there are many minor channels radiating from the fanheads (Figure 3.1, see also Appendix I). Over much of the Fan surface pebbles and smaller calibre rock fragments are organised in gilgai, with merely a scatter of cobble size material and a few isolated boulders. Poorly defined channels and strings of coarser alluvial material indicate former minor stream channels.

## 5. Drainage Basins

The catchments of the Brachina and Bunyerroo creeks cover 350 and 127 square kilometres, respectively. Combined they are approximately twice the area of the Brachina-Bunyerroo Alluvial Fan, a ratio comparable to that noted for the Parachilna Creek catchment and alluvial fan (Table 4.1). Relief amplitude and ruggedness are also of the same order as those of the Parachilna Creek catchment. Despite outcrops with well defined strike, the drainage pattern of Brachina and Bunyerroo creeks is dendritic and the basins roughly circular in shape (Figure 4.3).

## 6. Minor Alluvial Fans

Several minor alluvial fans are inset in the surface of the main pediment in the Parachilna-Brachina section of the Heysen Range piedmont (Figures 3.1 & 4.10, Table 4.4). All are associated with stream systems which have headed back beyond the Rawnsley Quartzite ridge to erode argillaceous sediment from drainage basins larger than 3 square kilometres in area, e.g. the catchment area of Five Mile Creek (5 in Figure 3.20) was doubled as a result of capture of a stream system eroding an area of argillite. Drainage from Tea Cosy and Bathtub minor alluvial fans has effected considerable dissection of the main pediment associated with tributaries of Warekila Creek. Five Mile, Tea Cosy and Bathtub creeks have fourth order basins (after Horton, 1945; Strahler, 1957), which gives some measure of the complexity of streams eroding their catchments and transporting alluvium to the piedmont (Figure 3.20, Table 4.4). The apices of the associated minor alluvial fans occur at the scarp foot. The other minor alluvial fans, which have been deposited hundreds of metres away from the scarp foot, are related to mature third order basins where the order is attained near to their headwalls. Thus, Barregowa North and South and Bundulla creeks are confined to relatively narrow channels, incised in the main pediment for some 2 kilometres distance from the upland, before depositing their minor alluvial fans. Similarly, when the main northern tributary to Walkandi Creek, which now flows southwest, followed the piedmont slope westwards, it deposited a minor alluvial fan (Figure 4.10). Many of the streams dissecting the main pediment surface spread finer sediment over the surface near the outer margin of the pediment apron and then erode channels through those deposits in times of flood: these are regarded as incipient alluvial fans (Figure 4.10).

Minor alluvial fans are inset within and some 10 metres below the level of the main pediment (Figures 3.1 & 4.10). The length of minor alluvial fans is restricted to that of the pediment apron and is shorter for those which do not head at the upland. Regression analysis shows that these piedmont landforms are related to their catchments in respect of length and area (Appendix II: Minor Alluvial Fans). The axis profiles of the minor alluvial fans slope at an average of  $1.9^\circ$  (Table 4.4). Transverse profiles display the convexities typical of alluvial fan deposits (Figure 3.3). The thickness of these deposits

has not been determined: it is thought to be thicker than the alluvial cover of the main pediment, but thin relative to the major alluvial fans.

## 7. Riverine Outwash Plains

Riverine outwash plains are defined as fan-shaped forms associated with catchments larger than those typical of pediments in the study area (see Chapter Three). It was established that they are not minor alluvial fans, despite the fact that the slope of the surface is comparable, for they are virtually flat and their catchments are restricted to resistant outcrop. The riverine outwash plain associated with the Walkandi Creek system (15 *in* Figure 3.20 & Table 4.4) differs from the other examples, in that it occurs within the pediment apron and resembles, in plan, a complex of incipient fans. It is associated with a drainage basin which is scarcely larger than those associated with pediments. Incipient alluvial fans are negligible forms which are commonly developed near the toeslopes of the main pediment surface and in association with streams, other than the master streams, which dissect the pediment apron (Figure 4.10). In an alluvial fan environment they would be termed secondary fans, for their deposits represent the reworking of the material of the original form - in this instance, a pediment. The multiple fan form associated with Walkandi Creek may represent the intermediate stage between the incipient alluvial fan and the riverine outwash plain and minor alluvial fan.

The Ilina Creek North stream system is also exceptional (17 *in* Figure 3.20, Table 4.4). The associated catchment is larger than those draining to pediments and it is restricted to the resistant outcrops of the upland, but in morphological terms it is not associated with a riverine outwash plain. The stream flows south behind a prominent strike ridge to join Brachina Creek, and at least 10 metres of alluvium have been banked behind the ridge giving the form an apparent convex-upward transverse profile. Its surface is distinguished by gilgai developed in the bouldery clays (Figure 4.11). Morphologically the fan-shaped landform is a minor alluvial fan.



## B. WYACCA-EMEROO REGION

### 1. General Statement

Major alluvial fans dominate the assemblage of landforms found in the Wyacca-Emeroo piedmont, which is delimited to north and south by large alluvial fans associated with the Willochra and Mundallio creeks, respectively (Figure 4.3). As for the Parachilna-Edeowie region, to avoid needless repetition, the alluvial fans will be described as a group rather than individually.

Rhynie Sandstone, or the Emeroo Quartzite equivalent, backed by Skillogalee Dolomite provides a resistant scarp face to most of the Wyacca-Emeroo ranges. Wilkatana North and South, Depot and Deep creeks have extended east of these strata via fault related gorges to drain catchments in argillaceous sediments. Between Thompson and South creeks the sandstone has been faulted out, and the dolomitic and calcareous sandstone strata have proved less of an obstacle to incising and regressing streams: Thompson, Dry South, and South creeks have extended back into the upland. All these streams have deposited major alluvial fans, which occur adjacent to the highest parts of the upland (*cf.* Melton, 1965b), namely the upwarped axis between synclines plunging to north and south (Figure 4.2). To either side of this central section of the upland, in the Wyacca and Emeroo ranges proper, the scarp is buttressed by massive quartzite. Minor streams drain catchments confined to the front ridges of resistant strata, and no major alluvial fans have been deposited (Figure 3.37).

### 2. Alluvial Fans

#### (a) Dimensions

Fan apices occur at the point of debouchment from the upland of the streams (Figure 3.2). Most form individual fan shapes, but there are two exceptions. The lower slopes of the Wilkatana South alluvial fan have coalesced with those of Wilkatana North, and the deposits

of Dry South Creek have merged with those of South Creek. Fan margins are delineated by their diverted trunk streams, e.g. Wilkatana South, Thompson, South, Deep and Mundallio creeks, and by tributaries of interfan streams, e.g. Connolly Creek and several others which are unnamed (Figure 4.12). None of the streams reach the meridional line of swamps and salinas in the axis of the Port Augusta Corridor some 5-9 kilometres from the toeslopes of the alluvial fans, but subsurface the waters must flow to the head of Spencer Gulf and sea level.

There is no basis for comparison in the measurement of alluvial fan area, for this varies from 13.5 to 44.5 square kilometres (Table 4.1) and is not consistent with available space in the piedmont zone. The area of most of the alluvial fans of this region is approximately equal to that of its related drainage basin, although Wilkatana North, Wilkatana South and Dry South alluvial fan areas are exceptional. Each is approximately twice the area of its catchment, reflecting the relative proportion of more easily weathered and eroded sediment in those drainage basins. The axis lengths of the alluvial fans are of the order of 4.5 to 9.0 kilometres (Table 4.1).

#### (b) Deposits

There is little information on the origin or age of the sediments. About 10-15 metres or so of the alluvial fan depositional sequence are exposed where fanheads are dissected by their master streams. Available borelog information is scant and restricted to the northern part of the region, where a wedge of Cainozoic sediments some 140 metres thick, and thicker nearest the upland, includes Eocene material in the basal beds and overlies Cambrian bedrock sloping gently west (see Chapter One).

Angular material is contributed to the upper parts of most alluvial fans in the piedmont of the Wyacca-Emeroo ranges in the form of talus cones and rock screes (Figure 4.13). It is not clear if major debris flows have ever used the main stream channels. Certainly the supply of abundant sediment is assured. The regular occurrence of summer thunderstorms is documented, and storm cells are of a size suitable to fall within most of the drainage

basins associated with the alluvial fans of this region (J. Dickens, pers. comm., 1994; see Appendix IV), just as Beaty (1990) stipulated for the initiation of debris flows. Occasional lenses of coarse, unsorted debris, typical of debris flows, were noted in many of the sections exposed in fanhead trenches (Figure 4.14) and comparable deposits have been reported from Depot and Hookina creek deposits (Gostin & Rust, 1983; Winterer & von der Borch, 1968).

However, streams are, and have been, the principal agent of deposition in the western piedmont of the Wyacca-Emeroo ranges (Figure 4.15). Cobbles, pebbles, and sand line the channels of most of the streams throughout their length. Blocks, 1-2 metres across, have been carried well into the fan proper, in places 2 kilometres from the upland. The lithology, shape and size of the material carried in contemporary braided channels are similar to those of the rock debris distributed within the alluvial fan deposits and over the fan surfaces (Figure 3.36b). On the proximal and mid fan surface slopes, there are spreads of coarse debris associated with minor streams, either transported to the site or exposed from the fan deposit by washing out of fines, in desert pavement or areas of gilgai development, and in strings of boulders or old stream bars. On the distal slopes of the alluvial fans there is a minimal scatter of relatively small rock fragments in sands and clays with occasional lenses of pebbles and grit. This signifies either that the alluvium has been transported over several kilometres, or that these are secondary fan deposits made of reworked, and therefore less coarse, alluvium. In addition, the finer deposits of the lower fan slopes may also be intercalated with basin and playa deposits.

### (c) Slope and Surface

The surface of the major alluvial fans, measured along the axis, slopes at about  $2^\circ$ . Some of the breaks of slope on the axis profiles (Figure 4.16) indicate different phases of deposition. Steeper,  $2^\circ$ - $3^\circ$ , slopes occur, for example, where talus deposits derived from the scarp merge with those of the alluvial fans or where detritus covers an erosional surface near the fanhead.

The largest subangular to subrounded rocks decrease in size and frequency with the fan slope and distance from the scarp (Figure 4.17, see also Appendix V). On the upper and middle 2° slopes, boulders measured on their longest axis are mostly 300mm to 120mm (maximum 470mm). Downfan, and especially below the intersection points where streams are wholly responsible for the transport of sediment, slopes are more gentle, 1°-2°, and boulders measure 180mm to 90mm. Little or no rock fragments occur on the even gentler, 0.5°-1°, gradient of midfan and lower fan slopes.

Whether the slopes vary with azimuth was examined (Figure 4.16). Such shorter slopes are expected to be steeper, because of larger debris size, higher sediment concentration and smaller discharges. Within 500 metres of the fan apex steeper slopes occur on the flanks of Wilkatana North and Deep fans on the 22.5° azimuth, but at 45° to the axis the flanks of those fans slope more gently. Steeper azimuth slopes on Depot, Thompson and Dry South fans merely reflect the position of their main braided stream channels, which flow at, and undercut, the fan margins. Axis and azimuth slopes of Wilkatana South and South fans are uniform.

#### (d) Segments

Three periods of fluvial deposition, represented by fan segments, can be identified on most of the alluvial fans of the Wyacca-Emeroo region (Figures 3.2 & 4.18), although similar patterns were not found on those of the Parachilna-Edeowie region.

#### (i) Main Surface

The main surface is of yellowish-red alluvial deposits, usually patterned with gilgai. Little relief amplitude is apparent on the surface of the largest alluvial fans, e.g. Wilkatana North, Depot and Mundallio. There are occasional groupings of large cobbles and boulders, which probably indicate a former channel bar. In time, denudation has modified surface features to make old channels indistinguishable. This process has been aided by the churning of the upper layers of soil and rock during the development of gilgai.

The main streams are entrenched in all the major alluvial fans to a maximum of some 8-15 metres near the fanheads. Depot and Thompson creeks are entrenched throughout their length and end in a spread of alluvium, similar to other small secondary fan deposits. The gradients of the main alluvial fan surfaces and beds of the stream channels measure approximately  $2^\circ$  (in the field), but there is a subtle difference between the two profiles because most of the streams emerge at midfan intersection points. Within 500 metres of the fan apex streams are typically incised some 4-6 metres, and then 2 metres, in their alluvial fan deposits, before reaching the intersection point (Figure 4.19). This point, which occurs 1-3 kilometres from the fanheads, marks the lower boundary of the dissected fanhead and the upper limit of younger fan deposits radiating downslope related to the master stream in its present position.

Changes in loci of deposition are thus evident downfan, especially in relation to the position of intersection points, but they have also occurred in a lateral sense. For example, if channels are blocked by earlier deposition overbank flow occurs to lower parts of the alluvial fan surface and underladen water rapidly cuts new channels. Depositional lobes are made obvious by their surface morphology (Figure 3.2).

#### (ii) Bar and Pavement Surface

Paired and unpaired terraces of brown alluvial deposits occur some 1-2 metres above the bedload deposits within the entrenched channels of the main braided streams. Their bar and pavement morphology is distinctive and demonstrates the softening effects of weathering and erosion of an older bar and channel topography (Denny, 1967; Hooke, 1972). Dry South Alluvial Fan is predominantly of bar and pavement topography (Figure 4.20), and many of the alluvial fans include large segments of this surface, e.g. Wilkatana North, Thompson, and Deep (Figures 3.2 & 4.18).

### (iii) Bar and Channel Surface

Bar and channel topography, also in brown alluvium, is limited to the beds of contemporary streams, many of which are braided systems and are tens of metres across. In addition, a complex of minor streams, diverted around bars of alluvial material built out from either bank or deposited on the channel bed itself, are incised to a depth of only 1-2 metres in the main surface of most alluvial fans in the study area. Channels are relatively straight and braided in the upper fan section where there is abundant coarse material. Where they flow through generally fine sediment with only occasional lenses of pebbles and cobbles further downslope, the channels meander (Figure 4.18). A bedload of pebbles and cobbles occurs in any stream more than a metre deep, even in the distal sections where few or no rock fragments lie on the surface between the channels. There, too, minor streams are heading back to comb out material from the fan and redeposit it further downslope in small secondary fans.

### (iv) Significance of Alluvial Soil Colours

Both the lower, younger alluvial deposits are brown in colour, in marked contrast to the yellowish-red alluvium of the main surface. At many sites streams have scoured their channels in yellowish-red alluvium and deposited the brown coloured sediments, e.g. Depot, Wilkatana North, Dry South and South creek beds, thus clarifying the stratigraphic relationship of older and younger alluvial surfaces (Figures 4.21 & 4.22). In order to record differences in colour, chemical composition, sediment texture and types of clays present, two soil samples were taken from the surface of each of six of the alluvial fans of the Wyacca-Emeroo region. The Parachilna-Edeowie region was not sampled, because no pattern of fan segments nor a relationship with soil colour were observed.

The hue, value and chroma (Munsell Color, 1975) of the bulk soil samples are listed in Table 4.5. Reddening of sediments has been interpreted as a measure of aging, the changes in depth of colour thought to be caused by additional coatings of iron oxide and an increasing proportion of grains weathered in time (e.g. Norris, 1969; Walker, 1979).

Table 4.5 'Munsell Soil Colors' of bulk samples.

ALLUVIAL FAN	SAMPLE	SURFACE & MORPHOLOGY	'MUNSELL SOIL COLOR'
DEEP	965-51	upper/with gilgai	5YR 4/6:yellowish-red
DEEP	965-52	lower/bar & pavement	7.5YR 4.5/4:brown-dk br
SOUTH	965-53	upper/with gilgai	2.5YR 4/6:red
SOUTH	965-54	lower/bar & pavement	7.5YR 5/4:brown
DRY SOUTH	965-55	upper/with gilgai	7.5YR 4/6:strong brown
DRY SOUTH	965-56	lower/bar & pavement	7.5YR 4/4:brown-dk br
THOMPSON	965-57	upper/with gilgai	5YR 4/6:yellowish red
THOMPSON	965-58	lower/bar & pavement	7.5YR 5/6:strong brown
DEPOT	965-59	upper/with gilgai	5YR 4.5/6:yellowish red
DEPOT	965-60	lower/bar & pavement	7.5YR 4.5/6:strong br
WILKATANA	965-61	upper/with gilgai	5YR 4.5/6:yellowish red
WILKATANA	965-62	lower/bar & pavement	10YR 4.5/4: dk yellowish-brown

However, there are no studies relating the various red soil colours to particular ages for the Flinders Ranges piedmont, and in alluvial fans it is doubtful whether the reddening and/or weathering of sediment has taken place entirely *in situ*. Some must have been inherited, for obviously the sediment was stored within the drainage basins on valley-side slopes and in channels, and was subject to weathering prior to being flushed out of the uplands into the piedmont zone to form the alluvial fans. Moreover, some of the colour may reflect the nature of the parent material.

Various tests were applied in an effort to account for the more-or-less consistent colour differences of fan segment deposits. Microscopic examination indicated that the bulk of the samples were of quartz, and so fine that they are virtually muds. This confirmed an earlier sedimentary analysis of Depot and Wilkatana alluvial fan sediments (Williams, 1973).

Different source rock is not responsible for the colour contrast in the soils of the upper and lower surfaces of the fans. Despite the apparent variety of rock occurring in the folded sequence in the Wyacca-Emeroo ranges, similar amounts of the same minerals were found in all samples. All the minerals identified by X-Ray Diffraction analysis of the bulk samples can be accounted for in the geologic succession of sedimentary and metamorphic rocks in the upland, across which are eroded the drainage basins of the streams depositing the alluvial fans (Table 4.6; see Appendix VI). Quartz is the dominant mineral and feldspar (usually plagioclase) is the most abundant minor constituent. There is a relative abundance of hydrous aluminosilicates, i.e. mica (usually muscovite), chlorite and kaolinite, listed as accessory minerals (Pettijohn *et al.*, 1987), and the least abundant minor constituents are the non-silicate minerals, calcite and dolomite.

The development of gilgai on the upper, older alluvial fan surfaces indicates the probable occurrence of swelling clays in those soils (Springer, 1958; Hubble *et al.*, 1983) and, perhaps, their absence in the sediments forming bar and pavement and channel, where there is no gilgai. The presence of swelling clays was suspected from a few of the bulk sample traces, and particularly in those where chlorite was present, e.g. Figure 4.23 (E. Molina



Table 4.6: Summary of X-Ray Diffraction analysis of bulk samples (see Appendix VI for all data).

	SAMPLE NUMBER & ALLUVIAL FAN NAME											
	DEEP		SOUTH		DRYSOUTH		THOMPSON		DEPOT		WILKA N	
Mineral	965-51	-52	-53	-54	-55	-56	-57	-58	-59	-60	-61	-62
QUARTZ	D	D	D	D	D	D	D	D	D	D	D	D
FELDSPAR (Plagioclase)	A1	A1	A2	A1	A1	A1	A3	A1	A1	A2	A1	A2
MICA (Muscovite)	A2	A3	A1	A3	A3	A2	A1	A2	A2	A3	T	A3
KAOLINITE	A3	A2	A3	+?	+?	+?	A3	+?	A3	+?	A2	A4
CHLORITE	+?	+?	+?	A2	A2	A3	+?	A3	+?	A1	T	A5
DOLOMITE	A4	A4	-	A5	-	-	A5	A5	T	A4	T	A1
CALCITE	T	-	-	A4	A4	-	A4	A4	T	A5	T	A6

**Key:** Table 4.6

D: Dominant mineral (perhaps as much as 90% of Sample)  
 A1-A6: Accessory minerals, in order of quantity (10%-3% of Sample)  
 T: Trace (0.01%-3% of the Sample)  
 +?: Occurrence of Kaolinite and Chlorite not exclusive

Ballesteros, pers. comm., 1992), so the clay fraction was isolated from most of the bulk samples for X-Ray Diffraction analysis (Table 4.7; see Appendix VI).

The presence or absence of chlorite is made clearer in the clay traces, being identified by the 14Å peak. However, where chlorite is present it is still difficult to say with certainty whether kaolinite is also present or absent. Although the resolution of the nominally 3.55Å peak into two peaks, e.g. clay fraction trace 965.52 in Figure 4.24, is diagnostic of the presence of both chlorite and kaolinite, this only works well for well-crystallised minerals. With the presence of chlorites more or less resolved and the convexities displayed on the graphs enhanced in several of the clay fraction analyses, ethylene glycol was added to the samples to elucidate further the presence of smectites (Figure 4.23). Smectites are present when chlorite is defined as the dominant mineral (except sample 965.55), and probably absent when muscovite is the most abundant (Table 4.7). There is some correspondence between the presence of swelling clays and the occurrence of gilgai, but smectites are recorded where gilgai has not developed and gilgai occurs where no smectites were found. Swelling clays are, therefore, not definitive for the upper, older fan surfaces of yellowish-red alluvium.

Only the colour of the alluvium and, of course, the surface morphology of the deposits consistently identify the various fan segments in the Wyacca-Emeroo region.

### 3. Drainage Basins

#### (a) Dimensions

The largest drainage basins associated with Depot and Wilkatana creeks are more than 35 square kilometres in area. In particular, Depot Creek has headed back further east than any of the others. Each of the drainage basins of Thompson, South and Deep creeks covers about 12 square kilometres, but those of Dry South and Wilkatana South creeks are smaller, being about 7 square kilometres in extent (Table 4.1). The last named streams debouch from the upland close to those of South and Wilkatana North creeks, respectively,

Table 4.7 Summary of X-Ray Diffraction analysis of clay fraction of samples.

Mineral	SAMPLE NUMBER & ALLUVIAL FAN NAME											
	DEEP		SOUTH		DRYSOUTH		THOMPSN		DEPOT		WILKA N	
	965-51	-52	-53	-54	-55	-56	-57	-58	-59	-60	-61	-62
QUARTZ	A2	A3	A3	A4	A3	A2	A3	A3	A3	A2	No	
FELDSPAR	A4	A4	-	A6	-	A3	A4	A5	-	A4	analysis	
MUSCOVITE	D	D	A2	A1	A2	D	D	A2	A2	A1		
KAOLINITE	A1	A2	A1	A2	A1	-	A1	A1	A1	-		
CHLORITE	A3	A1	D	D	D	A1	A2	D	D	D		
CALCITE	-	A5	-	A5	A5	A4	-	A6	-	-		
TALC	?A5	A6	A4	A3	A4	A5	-	A4	-	A3		
SMECTITE CLAY	-	?	YES	YES	-	-	?	YES	YES	YES		

Key: Table 4.7

- D: Dominant mineral (perhaps as much as 90% of Sample)
- A1-A6: Accessory minerals, in order of quantity(10%-3% of Sample)
- : No traceable quantity
- YES: Present
- ?: May be present

and may have developed their catchment areas at the expense of their neighbours. Certainly Dry South Creek is associated with an alluvial fan which is predominantly of the bar and pavement surface and, therefore, thought to be younger than the adjacent main alluvial fan surface of South Creek.

Most of the large basins in the Wyacca-Emeroo ranges are elongated southward parallel to strike (Figure 4.25). Bands of differing rock type dipping steeply ( $45^{\circ}$ - $50^{\circ}$ ) to the east trend roughly north-south across the catchments, e.g. Deep Creek (Figure 4.26a). The floors of the drainage basins of Thompson, Dry South, South and Deep creeks slope northward towards the axis of the opposed plunging synclines, whereas the floor of the Depot Creek catchment slopes southward into the axis. That of Mundallio Basin is inclined to Pichi Richi Pass in the south.

Drainage basin relief is approximately 600 metres for those catchments associated with major alluvial fans (Figures 4.2 & 4.26c). Greatest basin relief, measured from the gorge mouth of the basin to the highest point on the drainage divide, was found for Depot, Deep and Mundallio basins. The degree of ruggedness is inversely related to basin relief (Table 4.1) and reflects the bedrock types underlying the catchment (Figure 4.26a & b).

#### (b) Drainage Pattern

Some measurement of the stream network and consideration of the drainage patterns and relative size of the drainage basins associated with alluvial fans in this region demonstrates that, in those terms, it is comparable to the Parachilna-Edeowie region, but everything is at a reduced scale.

Application of the stream ordering methods, proposed by Strahler (1957), which modifies that of Horton (1945), and by Shreve (1966), merely showed that the larger the basin, the more complex is the stream system that erodes it (Table 4.8). Indeed, many extra first order basins are not included in these counts, because the 'blue-line' network mapped for perennial streams is less extensive than the potential channel network, indicated by contour

Table 4.8 Drainage basins of Wyacca-Emeroo region listed according to stream ordering methods

'STREAM ORDERING'			'SEGMENT ORDERING'		
Strahler (1957)			Shreve (1966)		
NAME	ORDER	POSITION	NAME	SEGMENTS	<i>cf.</i> BASIN AREA (km)
MUNDALLIO	5	mouth	MUNDALLIO	311	32.10
DEPOT	5	middle	DEPOT	236	39.51
THOMPSON	5	mouth	THOMPSON	166	13.05
SOUTH	5	mouth	SOUTH	129	11.58
WILKATANA NORTH	5	mouth	WILKATANA N	125	16.41
DEEP	5	mouth	DEEP	95	11.73
DRY SOUTH	4	middle	DRY SOUTH	77	7.14
WILKATANA SOUTH	4	mouth	WILKATANA S	43	6.38
<i>Wilk S</i>	3	middle	<i>Wilk N</i>	30	1.78
<i>Ukat</i>	3		<i>Ukat</i>	21	2.41
<i>Wilk N</i>	3	middle	<i>Wilk S</i>	13	1.37
<i>Emeroo S</i>	3		<i>Emeroo S</i>	5	0.69
<i>Emeroo N</i>	3		<i>Emeroo N</i>	4	0.66

crenulations (Kennedy, 1978), e.g. Figure 4.26d. Nevertheless, a stream and its catchment can be classified using stream ordering methods and an appreciation gained of the amount of stream flow produced by a particular network (Ritter, 1978). Whichever stream ordering method is used the drainage basins of the Wyacca-Emeroo ranges tend to be indexed in similar fashion, although there is no absolute correlation with basin area for those larger than 32 square kilometres.

The overall slope of the catchment drained by a stream and its tributaries, even in folded sediments, may initially give rise to parallel drainage lines and tends eventually to develop a dendritic pattern, which is typical of the fourth and some of the fifth order basins, e.g. Wilkatana South, Thompson, Dry South, and South basins. Fifth order basins are significantly larger than the others and their stream systems comprise several captured tributary stream networks, most of which display structural control in their drainage patterns. Sections of the main streams are also eroded along lines of weakness, both lithological and structural. Angular drainage patterns are typical of the well-jointed sandstone and quartzite strata and dendritic patterns are developed on the weaker shale and siltstone. The beginning of the highest order stream occurs at the mouth of all these basins, except for that of Depot Creek (Table 4.8).

### (c) Sediment Supply

A ready and abundant supply of sediment is a prerequisite for the deposition of alluvial fans. Obviously streams draining a folded sedimentary sequence can easily erode any argillaceous strata. Valley side slopes are scored by gullies 2-3 metres deep, where dipping beds of varying resistance are differentially weathered. On the less resistant rocks of the catchment areas in the Wyacca-Emeroo region downwasting and volume loss together with the smaller calibre of rock debris result in more gentle, less than  $24^\circ$ , slopes (Figure 4.26b, Table 4.9). Otherwise, the slopes are covered with loose debris held by trees and shrubs. Lobes of clay, silt and pebbles occur where the regolith is thickest. Throughout the drainage basins there are accumulations of weathered bedrock and stream bedload stored in the stream channels, e.g. alluvial terraces, stabilised by vegetation, stand some 1.5 to 2

Table 4.9 Percentage slope measurements in Deep Creek drainage basin (after Strahler, 1952). See Figure 4.26b.

MEASUREMENTS TAKEN NORMAL TO SLOPE OF VALLEY-SIDE

SLOPE SEGMENT	HORIZONTAL DISTANCE metres	ALTITUDINAL DIFFERENCE metres	SLOPE		HIGH or LOW %SLOPE
			%	°	
1	400	220	0.55	28.8	H
2	350	200	0.57	29.7	H
3	400	200	0.50	26.6	H
4	300	70	0.23	13.1	L
5	250	60	0.24	13.5	L
6	225	50	0.22	12.5	L
7	450	145	0.32	17.8	H
8	250	100	0.40	21.8	H
9	475	130	0.27	15.3	H
10	450	40	0.08	5.1	L
11	300	40	0.13	7.6	L
12	600	200	0.33	18.4	H
13	650	220	0.34	18.7	H
14	400	218	0.55	28.6	H
15	200	40	0.20	11.3	L
16	250	70	0.28	15.6	H
17	500	90	0.18	10.2	L
18	350	130	0.37	20.4	H
19	300	50	0.17	9.5	L
20	175	40	0.23	12.9	L
21	225	30	0.13	7.6	L
22	325	60	0.18	10.5	L
23	200	30	0.15	8.5	L
24	250	170	0.68	34.2	H
25	200	110	0.55	28.8	H
26	250	100	0.40	21.8	H

Source: 1:50 000 Topographic Series, map sheet 6433-2 Port Augusta,  
Department of Environment and Natural Resources, South Australia.

metres above the present active channel of Deep Creek (Figure 4.27a). In places, tree trunks and boulders combine temporarily to dam back debris in the channels. Bedrock bars also retard the movement downstream of the bedload (Figure 4.27b). Lobes of material are deposited when tributaries join the main channels and when rockfalls and minor debris flows from steep valley-side slopes form small talus cones on the stream bed (Figures 4.13a & 4.27c).

Even the more resistant ridges are prone to effective physical and chemical weathering. Broad scree slopes and gullies filled with rock fragments occur on most of the sandstone and quartzite ridges of the study area (Figure 4.25), but are best displayed in the Wyacca-Emeroo region (Figure 3.2), on faceted slopes, either eroded across exposed bedding planes, as in the vicinity of Wilkatana North Creek, or cut through resistant ridges (Figure 4.13b). Valley-side slopes are typically steep,  $32^{\circ}$ - $42^{\circ}$ . Much of the rock debris, which is moved from valley-side slopes into the stream channels, remains angular. This is due to its resistance to weathering, a tendency to splitting and/or to the short distance of transport.

Rock fragments are released from the outcrops when triggered by seismic movement, heavy rains or gradual undermining and collapse of the bluff. Gravity fall, wet mass movement, and possibly subsurface sapping beneath the rock debris, result in spreads of talus and streams of rock moving downhill. Rudimentary sorting by size is evident, for the coarsest size blocks have gravitated to the lowest parts of the rock debris sheets and streams, while less coarse rock debris lies to either side (Figure 4.28). The sandstone and quartzitic rock debris consists of an open matrix of unsupported rock with any fines flushed down and out of the deposit. Movement of these masses as debris flows would be possible, but none has been observed. Large blocks, 1-3 metres across, are rafted downslope over a carpet of smaller rubble where different rock types are involved, where two distinct joint systems occur in the one outcrop, or where boulders of relatively fresh rock move downslope over the weathered bedrock of debris slopes.



#### 4. Minor Alluvial Fans

As noted in Chapter Three, in the piedmont zone of the Wyacca Range north of Wilkatana North Creek and of the Emeroo Range south of Deep Creek, alluvium covered pediments occur within 200 metres of the scarp foot and thereafter the alluvial apron thickens basinwards. Thicker fan-shaped deposits of the alluvial cover occur in association with a few third order drainage basins (Tables 4.1 & 4.8). Thus they are not strictly comparable to the minor alluvial fans of the Parachilna-Edeowie region for their streams have not eroded and deposited alluvium in broad depressions below the level of the pediment surface.

In the Emeroo Range the 2.41 square kilometre drainage basin of Ukat Fan is larger than the other four examples (Figure 3.37a, Table 3.4): its stream has captured part of the Mundallio tributary system. The other basins are smaller, 0.66-1.78 square kilometres, and are restricted to the Emeroo Quartzite and Skillogee Dolomite beds. All five have short basin lengths measured parallel to the main streams and little basin relief (Figure 4.1). Coarse detritus has been transported from valley-side slopes by small streams, wash and gravity into the stream systems. It is noticeably more angular than that of the major alluvial fan deposits. Stream discharge is minimal. The streams which deposit these minor fans erode shallow channels in the lobes of coarse angular deposits (Figure 4.29), the surfaces of which slope away from the upland at some 3°-4°.

### III. DISSECTION AND DATING OF THE ALLUVIAL FANS

Major alluvial fans draining large catchments of the Flinders Ranges are inset within, and stand lower than, the pediment surfaces which fringe the upland. All the major streams flowing westward from the Flinders Ranges towards Lake Torrens and the line of lakes linking it with the head of Spencer Gulf are incised in their alluvial deposits as they emerge from the upland. Indeed the incision can be traced back along the largest rivers, e.g. in the broad alluvial former valley floor of the Hookina, in the alluvial terraces of the Brachina and perhaps in the Y-shaped valleys, hanging tributaries, embayments and

shoulders of the Wyacca-Emeroo ranges indicating former broader valleys above the narrow gorge mouths of the present streams. Those streams, which have built major alluvial fans within the western piedmont of the Flinders Ranges, now flow in braided channels cut some 10 metres down into their fan deposits. Generally, the streams have dissected only the upper parts of the fans and emerge from the confines of their channel walls midfan, although those associated with the most extensive fans tend to be incised throughout the length of the fan.

No material suitable for absolute dating was found in the alluvial deposits of the Parachilna-Edeowie region, but they have been assigned, in general terms, to the Quaternary. However, the end phase of the main alluvial fan deposition associated with Wilkatana North and Depot creeks was correlated with the last glacial maxima and dated at some 30 000 years B.P. (Carbon 14 dating of detrital wood taken within 15 metres of the fan surface: Williams & Polach, 1971; Williams, 1973). Radiocarbon dates for the younger, lower surfaces indicate that the main fan surface was dissected about 5 000 years B.P. by streams which flowed at the bar and pavement level, before cutting a slightly deeper set of channels some 3 500-1 800 years B.P. (Williams & Polach, 1971; Williams, 1973).

Such shallow dissection of the alluvial fans may be simply part of the evolutionary development of alluvial fans as suggested by laboratory experiments (Weaver & Schumm, 1974; Schumm *et al.*, 1987). On the other hand, fan dissection may be in response to human occupation of the area or to changes in baselevel, climatic variation and/or change (see Chapter Five).

#### IV. CONCLUDING STATEMENT

Extension of, and weathering and erosion within, drainage basins ensure the large supply of rock and soil necessary for the deposition of alluvial fans in the western piedmont of the Flinders Ranges. Flushing that sediment out of the drainage basins and into the piedmont zone can be accomplished under present climatic conditions. Streams flow episodically, and the powerful effects of summer cloudbursts in arid and semi-arid regions have been

well documented (McGee, 1897; Pack, 1923; Beaty, 1963, 1970). The sediment supply stored in the channels of streams draining the uplands will be supplemented or replaced in future, for there is an abundance of loose detritus within the catchments. There is, however, little material lying in the main channels waiting for redistribution, suggesting that there may have been a recent flushing out of eroded material from the drainage basins. Instead, primary alluvial fan deposits are being reworked and secondary features deposited on distal slopes. Undoubtedly, the major alluvial fans of the study area have been affected by changes in baselevel in response to tectonism and especially to climatic changes during the Cainozoic. These implications will be examined in Chapter Five.

## CHAPTER FIVE

### PEDIMENTS AND ALLUVIAL FANS: GENESIS AND RELATIONSHIPS IN THE WESTERN PIEDMONT OF THE FLINDERS RANGES

#### I. STATEMENT OF PROBLEM

Though pediments and alluvial fans have a wider distribution, both landforms are characteristic of, and coexist in, the piedmont zones of uplands in arid and semi-arid lands. This study is concerned with the genesis and relationships of the two forms in the western piedmont of the Flinders Ranges, where pediments and alluvial fans occur in similar geological settings and in essentially the same climatic environment.

In Chapter One several specific questions were posed. They were concerned with the distribution of pediments and alluvial fans in the study area, the relative and absolute ages of the forms, and the processes responsible for their development. Two sectors of the western piedmont of the Flinders Ranges, the Parachilna-Edeowie and Wyacca-Emeroo, were chosen to illustrate the distribution of pediments and alluvial fans and to demonstrate some differences in their occurrence. Morphological maps were constructed (Figures 3.1 & 3.2) using various criteria for identification of the forms (see Appendix I). The landform assemblages were described in Chapters Three and Four.

#### II. DISTRIBUTION OF THE PEDIMENTS AND ALLUVIAL FANS

##### A. GENERAL STATEMENT

In summary, alluvial fans dominate the study area. The alluvial fans of the Parachilna-Edeowie region are the largest in the study area, though so gentle are their distal slopes that it is difficult to distinguish them from the alluvial flats of the Torrens Plain. To the south in the Wyacca-Emeroo region the alluvial fans are the dominant features in that landscape;

pediments are present but poorly represented by minor remnants. The pediments of the Parachilna-Edeowie region, however, are more prominent than in any other sector of the piedmont. The length of the fringing pediments is determined by faults, which are located marginal to the upland and which effectively truncate the toeslopes of the pediments throughout the study area.

Structure has played a significant role in determining pediment and alluvial fan formation, because bedrock, and notably fracture density in the sandstone and limestone of the front ranges, have influenced which streams have become the master streams and hence which have penetrated headwards and eastwards into argillaceous terranes. Thus, master streams like the Parachilna and Brachina have exploited fault zones (Figure 1.6) in the front ramparts of the uplands and have deposited major alluvial fans in the piedmont. On the other hand, streams like the Walkandi Creek, though controlled by fractures, is not located on a weakness sufficiently pronounced to allow its rapid regression. It remains confined to the limestone and sandstone of the western ramparts and has eroded pediments in the piedmont zone. Only incipient alluvial fans are associated with Walkandi Creek and they have resulted from the dissection and reworking of pediments (Figures 3.1 & 4.10). Indeed, it is the intrinsic strength of the limestone and sandstone escarpment between Parachilna and Brachina gorges, and in the Wyacca and Emeroo ranges proper, which has prevented its breaching by streams and accounts for the prominence of pediments in those sectors of the piedmont.

## B. EVOLUTIONARY SCHEME

Catchments are critical to understanding the distribution of pediments and alluvial fans in the study area. The catchments of the drainage systems serving pediments and alluvial fans differ in two major respects (Figure 5.1). The catchments draining to pediments are comparatively small and are characterised by outcrops of resistant strata which, on weathering, produce coarse detritus. Those catchments serving alluvial fans are both more extensive and dominated by argillite. For the most part this weathers to fine, platy fragments and to particulate debris readily transported some distance from the hill-plain

junction: hence the contrasted length, structure and composition of pediments and alluvial fans.

Map inspection of outcrop geology of catchments, and consideration of the weathering characteristics of outcrops, and the mean size of catchments serving pediments and alluvial fans, suggest that:

1. Catchments confined to resistant sandstone and limestone produce coarse debris.
2. On leaving the upland, streams from such catchments erode laterally and deposit an allochthonous cover to form covered pediments.
3. As the streams and catchments extend, they penetrate beyond the western ramparts of the uplands and into the extensive outcrops of siltstone and mudstone typical of the anticlinal core of the Ranges (Figure 5.2).
4. These extended rivers have an increased potential discharge/stream competence and load. The character of the load also changes, becoming finer, as a result of drainage development (*cf.* Bull, 1964b; Willgoose *et al.*, 1991).
5. Such rivers debouching from the uplands widen the narrow minor gorges cut below the pediment surface and eventually form broad valleys or depressions in which fanglomerates are deposited.
6. Some of the alluvial fan deposits head in the scarp foot zone, and extend distally and laterally beyond and overlap the pediment limits (Figure 5.2). Others, however, originate some distance from the scarp foot and the question arises whether the channel fill, implied by the deposition of fanglomerates, could cause upstream deposition of detritus? (Figure 5.3a & b).

According to Lawson (1915), Balchin & Pye (1955) and Denny (1967), regressive deposition is capable of extending to the upland margin. In the study area, the thickness of the deposits is known with certainty only for the Parachilna and Brachina-Bunyeroo alluvial fans, in both instances about 60 metres (Anonymous, 1982; Cockshell, 1983). Given that

mean slopes of pediments and alluvial fans are some  $3^\circ$  and  $0.3^\circ$ , respectively, in the Heysen Range piedmont, a build-up of a metre of fan materials would cause an upstream extension of about 20 metres (Figure 5.3c). An accretion of 60 metres would lead to a headward regression of some 1300 metres, which is comparable with the average 2.5 kilometre length of the pediment apron. No specific thickness data is available for the alluvial fans of the Wyacca-Emeroo ranges piedmont, but assuming a thickness similar to the region to the north, but taking account of the steeper gradients ( $4^\circ$  and  $2^\circ$ ) of the pediment remnants and alluvial fans in that region, backfilling of stream channels would cause fan regression of some 30 metres for an addition of one metre and some 1700 metres for 60 metres of alluvial fan deposits (Figure 5.3d).

Thus, distal, lateral and headward growth of alluvial fans is theoretically possible, but there is little field evidence in the study area of regressive fill, though this may reflect lack of deep sections and paucity of bore data. It is hoped that future drilling, or geophysical exploration might indicate such burial of covered pediments by fanlomeratic material. The only evidence of such burial is at Aliena Washout (see below).

Consideration of the areal extent and lithological character of the catchments leads to the suggestion that pediments and alluvial fans are members of an evolutionary sequence. Pediments are eroded first by streams draining small, rugged catchments restricted to the resistant strata of the upland escarpment. Then, as the drainage extends into the argillaceous core of the Flinders Ranges alluvial fans are deposited. This scheme accounts both for the relative ages, and the coexistence, of the two contrasted (erosional and depositional) major piedmont forms. Complications are introduced, first, by the deposition of a younger generation of alluvial fans related to the reworking of pediments, and second by the development of riverine outwash plains, which are construed as incipient covered pediments.

### C. INCIPIENT PEDIMENTS OR ALLUVIAL FANS?

Some streams in the Parachilna-Edeowie region have catchments which exceed in area those typical of pediments in the study area, yet are restricted to the resistant outcrops of the Heysen Range. Clearly defined pediments are not formed in their piedmont zones. Instead, there are broad, virtually flat flood plains. It can be postulated that, under catastrophic flood conditions, they will eventually be dissected. The washing out of fines and the concentration of the coarse detritus will convert them into covered pediments. Here, they are referred to as riverine outwash plains and are interpreted as representing the initial stage in the development of covered pediments (see Chapter Three).

The catchments of most of the riverine outwash plains, e.g. 3, 4 & 27 in Figure 3.20, are likely to extend into argillaceous terranes and their streams will then deposit minor alluvial fans. The Edeowie riverine outwash plain, however, is associated with an unusually large catchment (Figure 5.1), which is unlikely to extend beyond the resistant rocks of the Wilpena Pound structure (Figures 3.27 & 3.28, Table 3.1). As the nature of the catchment associated with the Edeowie riverine outwash plain is unlikely to change in the foreseeable future, the riverine outwash plain will persist until it is dissected.

The riverine outwash plain is, therefore, an integral part of the evolutionary scheme being suggested for the study area, in that it is the basic initial form which can develop into either a covered pediment, if maintained in resistant strata, or an alluvial fan, if the catchment extends into argillite.

### D. MAJOR ALLUVIAL FANS AND SHIFTS IN BASELEVEL

There is a marked contrast in scale between major alluvial fans and the other elements of the evolutionary sequence. However, major alluvial fans, like the other elements of the evolutionary sequence from the study area, viz. riverine outwash plains, pediments, incipient and minor alluvial fans, are associated with changes in size and character of their catchments. This is an inherent feature of their development.



The evolutionary scheme suggested for the sequential development of pediment and alluvial fan in the study area is independent of baselevel lowering. However, several workers, who have investigated other areas, have invoked tectonism as essential to alluvial fan development. Bull (1977), for example, distinguishes between thin temporary fans due to increased sediment yield or decreased competence of agencies transporting material across pediments in the piedmont, and orogenic forms, the deposition of which is related to tectonic movements.

In the study area lowering of baselevel due to tectonic movements may have facilitated the deposition of the major alluvial fans. That there has been upfaulting in the study area is evidenced by the reverse fault involving Late Pleistocene fanglomerates at the gorge mouth of Wilkatana North Creek and the truncation of the pediment surface which stands 40-60 metres above the level of the alluvial fans (Williams, 1973; Preiss, 1987). Putatively, and more remotely in time, faulting has occurred at the outer margin of the pediment apron in the Parachilna-Edeowie region, particularly between Brachina and Bunyeroo creeks (Dalgarno & Johnson, 1968; Cockshell, 1983). Such dislocations would have initiated stream rejuvenation, resulting in an increased supply of detritus to the piedmont, and provided space for the accumulation of the relatively thick wedges of sediment that form the major alluvial fans. Similar effects may have flowed from Quaternary lowerings of sea level and any falls in the level of Lake Torrens (see Chapter One).

### III. AGE RELATIONS OF THE PEDIMENTS AND ALLUVIAL FANS

In terms of the evolutionary sequence, pediments precede alluvial fans. Modern pediments including riverine outwash plains exist, but the statement holds for the major pediments and alluvial fans. All major pediments are dissected and are relic features. All predate alluvial fans, whether they are the older scarp foot type or the younger, distal-pediment type. The older generation of alluvial fans is being dissected, possibly in consequence of human interference with the environment, or of climatic change. Even this older generation of alluvial fans, however, is younger than the larger pediments, for they, like the

contemporary fans and riverine outwash plains, are deposited in valleys and depressions eroded into and below the level of the erosional surface.

The near-surface strata of alluvial fans located in the Wyacca-Emeroo region are of Late Pleistocene age (Williams, 1973), but there are no precise data on the age either of the basal parts of the fans or of the older pediments. They are Cainozoic forms and probably of later Cainozoic age, for the piedmont surface is underlain at depth by Cainozoic basin sediments of Eocene or, in some instances, (?)Miocene age, but there is no more precise information on this point.

#### IV. PROCESSES RESPONSIBLE FOR THE PEDIMENTS AND ALLUVIAL FANS

Both pediments and alluvial fans are fluvial landforms. In a folded sedimentary terrain, like the study area, the upland and piedmont zones are structurally determined. On emerging from the confines of their upland gorges, fully loaded streams divaricate across the lowland. They laterally corrade the bedrock surface and deposit their bedload, which forms an allochthonous cover. This protects the pediment surface between the stream channels. Where streams have extended their catchments into more and readily available sediment, they have built up the thickness of their alluvial deposits in the piedmont zone. The resultant landform will be intrinsically of depositional character, an alluvial fan.

Thus, streams are responsible for the development of both pediments and alluvial fans. And streams in flood are thought to be most effective (e.g. Davis, 1938; Rahn, 1967; Twidale, 1983a; Beaty, 1990). The change in process from planation to deposition reflects differences in discharge and volume and character of load.

At the present time, extreme rainfall events occur in summer in the Flinders Ranges, but also as part of the winter rainfall regime (Appendix IV). Comparing rainfall records with the preliminary stream gaugings taken for drainage basins adjacent to the study area has established that flood events follow the cloudbursts (see also Table AIV.3). For example, 104mm of rainfall was recorded at Hawker for 10 February, 1955 and 280mm was reported

from a rain gauge in the hills nearby. As a result, flood waters on Hookina Creek uprooted and carried full-grown eucalypts, destroyed the railway bridge and reached Lake Torrens (Twidale, 1966a; Dutton, 1975). However, relatively little change of channel position or the pattern of bars in major braided streams occurred in response to an extreme rainfall event in January, 1992 (Figure 3.29). Nor, indeed, have any significant changes been detected over a period of 34 years, which time spans several such meteorological events (Figure 5.4).

## V. RELATIONSHIPS BETWEEN THE PEDIMENTS AND ALLUVIAL FANS

### A. GENERAL STATEMENT

Pediments and alluvial fans are construed as end members of an evolutionary sequence, with pediments the initial forms and alluvial fans the later developments. Pediments stand higher in the topography than alluvial fans. Changes in size and character of catchments result in changes in discharge and volume and character and load of streams. Pediments are dissected and conglomerates deposited in the broad depressions so formed. Alluvial fans consume the pediments: pediments are in effect replaced by fans not by burial but by dissection and lateral substitution. This mechanism, as well as the influence of the lithological character of catchment, is illustrated by the Aliena Washout (Frontispiece).

### B. ALIENA WASHOUT

#### 1. General Statement

The pediments and alluvial fan of Aliena Washout, located south of Edeowie H.S., and in the piedmont plain between Wilpena Pound and Mount Burns, epitomise the relationships between the two landforms, which superficially appear the same, but the nature of which are morphologically, structurally and genetically quite different (Figure 5.5).

## 2. Pediments

### (a) Rock Pediment

Part of the upper slopes of the Aliena Washout is distinguished by a rare pediment, a rock fan (Frontispiece, Figure 5.6). An unnamed tributary of Aliena Creek drains a catchment eroded wholly in steeply dipping, red, dolomitic shales (Bunyeroo Formation). The area of the drainage basin is 0.29 square kilometres and its length is 800 metres. Where the stream leaves the upland it has eroded an elongate, fan shaped pediment, also in the red shales. There is no allochthonous cover. The pediment slopes down at  $6^\circ$  and numerous shallow channels, less than 1 metre deep, score the surface. The bare rock surface is about 0.4 square kilometres in area and its length is 800 metres. The toeslopes of the rock pediment are buried beneath an accumulation of shale fragments and soil washed downslope and alluvium contributed from either side by Siphon Well and Aliena creeks.

The bedrock exposed in the rock pediment is relatively fresh, but it is easily fragmented because of its fissile and brittle nature (Figure 5.6b). The bedrock surface can be regarded as exposed rock with shattered fragments. In this interpretation the feature is a rock pediment. Alternatively the fragments are sufficiently numerous to form a veneer over bedrock, in which case the feature is a mantled pediment; or they have been carried from the catchment to the plain, and the pediment is of covered type. The first interpretation is favoured.

### (b) Covered Pediment

A cover of allochthonous material has been deposited by the streams eroding the main pediment surface on either side and on the toeslopes of the rock pediment (Figure 5.5). Confined by upland slopes to the south, Aliena Creek flows parallel to the length, and along the southern margin of, the rock pediment. Siphon Well Creek emerges from the upland at a similar elevation to, and immediately north of, the stream eroding the rock pediment. The covered pediment slopes at some  $3-4^\circ$ . The pediment cover is minimal near the scarp

foot but thickens to some 2-3 metres in the vicinity of the two streams and downslope. Subrounded limestone and sandstone boulders up to 30cm diameter form the cover, although much larger boulders, up to 3 metres across, are exposed in the sides and beds of the streams, where travertine coats many of the cobbles and boulders. About 1.5 kilometres from the scarp foot, sandstone cuestas with strata dipping  $54^{\circ}\text{W}$ , strike bearing  $34^{\circ}$ , stand 20-30 metres above the surface. They are the weathered and eroded northernmost extension of the Elder Range (Figure 5.5). This ridge probably marks the outer limit of the pediment apron.

(c) High Pediment

An older, covered pediment remnant stands 3-6 metres above the present channel bed, and forms the northern bank, of Siphon Well Creek (Figure 5.5). It is covered with 1-2 metres of pebble and cobble size quartzite and sandstone detritus in a clay and sand matrix. The cover materials are mostly derived from the backing upland, but in places, additional rock fragments are contributed from sandstone outcrops at the pediment surface. The pediment is eroded across steeply ( $30^{\circ}$ - $50^{\circ}$ ) dipping, calcareous shales and limestones which otherwise form the ridges to either side. The surface is separated from the upland by a fault-line (scarp foot) valley although it can be traced a little way upstream within an embayment. The pediment slopes down from the upland at  $6^{\circ}$ , decreasing to  $3^{\circ}$  some 500 metres from the scarp, before being covered with the thicker alluvial deposits of the fan proper. A series of almost parallel streams some 3-4 metres deep dissect the surface.

Thus, the rock/mantled pediment of the scarp foot zone passes laterally into, and is succeeded downslope by a covered pediment, which includes the lower slopes of an older erosional surface. As the cover thickens downslope the pediment forms are replaced by the alluvial fan.

### 3. Alluvial Fan

The alluvial fan deposits are indistinguishable from the pediment cover on the mid slopes of Aliena Washout, but are much finer in the distal portions of the fan (Frontispiece). The area of the alluvial fan is twice that of the drainage basin (Table 4.4). The lateral spread of the alluvial fan deposits is constrained by the walls of Wilpena Pound to the east and the Mount Burns anticlinal structure to the west, resulting in the length of the fan being twice that of its drainage basin.

The fan surface is inclined at  $1.5^\circ$  and Aliena Creek intersects the surface as it levels out some 3 kilometres downslope. Minor streams are incised less than one metre in the alluvial fan surface. Gilgai are extensively developed on the fan surface. Where lenses of pebbles and cobbles, signifying old distributary creek channels, occur, rock fragments to 20cm are available to form stony flats, but even where rock is scarce, the gilgai patterns are still distinguishable by plant growth in hollows and channels. Some of the streams of the Aliena Washout join Wobma Creek, which skirts the footslopes of the fan as it drains northward to disappear in the sand sheet which masks the alluvial Torrens Plain (Figures 5.5 & 5.7).

### 4. Drainage Basin

Aliena Creek drains a catchment of some 11 square kilometres (30 in Figure 3.20). It has eroded a strike valley in shales between ridges of quartzite and sandstone underlying Wilpena Pound and Bunbinyunna ranges (Figure 5.5). The adjacent minor stream system, Siphon Well Creek, is confined to the resistant quartzite of Wilpena Pound Range.

### 5. Implications for Landform Assemblages of the Study Area

The relationships of pediment and alluvial fan for the study area are typified in the Aliena Washout, though here the nature of the piedmont plain changes systematically in a direction normal to the scarp, rather than along the scarp as in most of the region.

Streams eroded the pediment surfaces at the head of Aliena Washout when their drainage basins were smaller and restricted to the resistant front ridges of the escarpment of Wilpena Pound Range. Both the main pediment and an older, higher pediment surface were cut across steeply dipping, less resistant rocks and an allochthonous cover derived from the backing upland was deposited simultaneously.

Part of the main pediment surface is of rock type, which is, perhaps, merely fortuitous in that catchment and pediment are eroded in the same rock type and there is no allochthonous material available. On the other hand, in the Wyacca-Emeroo region, the location of remnants of a dissected rock pediment in the valley of Pettana Creek, a tributary of Willochra Creek, suggest that they have been stripped of their alluvial cover (Figure 5.8). Certainly the pediment cover has been removed from the rock pediment remnants of the Bundulla-Walkandi high pediment surface (Figure 3.21).

Once Aliena Creek breached the snout of the plunging anticline associated with Wilpena Pound and Elder ranges its catchment was significantly enlarged into an area of weaker rocks. The increase in drainage basin area, coupled with the easily eroded rock types of the Aliena catchment, ensured a ready supply of sediment for the deposition of the bulk of the alluvial fan which comprises the lower slopes of Aliena Washout.

Lithological contrasts between the rocks underlying the upland and the piedmont explains the initial erosion of the pediments, and extension of drainage systems accounts for the later deposition of the alluvial fan.

## VI. CONTRIBUTION TO THE STUDY OF PEDIMENTS AND ALLUVIAL FANS

This study of the landform assemblages in the western piedmont of the Flinders Ranges has corroborated many previously expressed ideas concerning pediments and alluvial fans. Some concepts, however, require modification in the light of this study, and in particular the proposed evolutionary relationship between pediment and alluvial fan is emphasised.

The following statements summarise the findings of this study of pediments and alluvial fans coexisting in a piedmont.

*Pediments are eroded across weaker members of the folded sedimentary sequence.*

*Most of the pediments of the study area are of covered type.* Covered pediments are formed, under flood conditions, by the simultaneous lateral planation of a bedrock surface and deposition by divaricating streams of alluvial detritus. Flights of pediments are evidence that such surfaces are inherently dissected and cut at lower and lower levels.

*Rock pediments occur in sedimentary terrain.* Remnants of older covered pediments survive in the piedmont of the Heysen Range. Most retain their cover but some siltstone remnants have been stripped and are now rock pediments. They are not etch forms because the present surface is not an exposed weathering front. The pediments at Aliena and Pettana appear to be rock pediments, but it is impossible, given the uniform character of the country rock, and the fact that it would fragment rather than become rounded during transport, to distinguish between shale fragments weathered *in situ* and any that may have been washed even a short distance downslope. Thus, though the features can justifiably be called rock pediments, they may include some mantled elements.

*The piedmont angle is due to the concentration of moisture and the effects of weathering in the scarp foot zone.* The piedmont angle is not primarily located at a structural break. Everywhere it is developed in the less resistant shale and siltstone, even in the Parachilna-Edeowie region, where the line of the piedmont angle is guided by the lithological junction with the massive limestone which forms the dip slope escarpment of the Heysen Range.

*The pediment cover comprises alluvial detritus comparable in size and degree of roundness with the bedload of streams dissecting the surface.* The thickness of the cover is consistent with the depth of channel scour and bar deposits associated with single flood events. The cover varies little in thickness between stream lines from that observed in creek cuttings.



*Pediments are not intrinsically nor essentially the planate surfaces left behind by scarp retreat* (e.g. King, 1949), for the dip slope structure of the pediments of the Parachilna-Edeowie region precludes scarp recession (on the contrary-Twidale, 1972). The upland margin in the Wyacca-Emeroo region has evidently been faulted but the abutment of pediments and alluvial fans against the base of the scarp suggest that it has been locationally stable through the period of piedmont development; in such circumstances neither scarp retreat nor pedimentation is a valid mechanism or model of landscape evolution. On the other hand, there is good evidence of scarp recession in the vicinity of Rawnsley Bluff. The highest and oldest remnants of a flight of pediment surfaces are also furthest from the scarp. Rock falls, and possibly debris flows, rather than stream deposits, form the pediment cover and testify to the erosion of the bluff and retreat of the bounding slopes of Wilpena Pound.

*Covered pediments are fringing forms* and do not dominate the landscape in geological settings like those found in the study area. Large calibre detritus, essential to the preservation of the form, cannot be carried far from the scarp foot. With distance from the upland there is no coarse protective cover so stream density increases and the surface is dissected. Interfluvial areas are wasted and rolling or undulating plains (peneplains?) develop (Twidale, 1983a).

*Scarp recession is operative where pediments, capped by a coarse debris cover, are dissected:* in the study area scarp retreat is active in the destruction of pediments but played no part in their formation.

*Distinguishing covered pediments from alluvial fans is difficult because the two landforms are morphologically similar.* The best means of identification in the study area are thickness of the alluvial deposit, remote sensing imagery and catchment characteristics. Other criteria, such as contour pattern, drainage density and length measured normal to the upland front, are viable for large, but not for small scale examples of the forms.

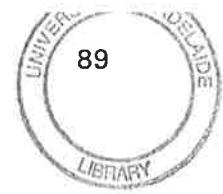
*Relationships between catchments and erosional and depositional landforms in the study area were clarified.* Pediments are associated with catchments which are relatively small and rugged and confined to resistant (sandstone and limestone) outcrop, whereas alluvial fans develop in relation to drainage basins which have been enlarged to include argillite and are less rugged.

*Pediments are not degraded alluvial fans.* Both the Edeowie and the Aliena examples, as well as the general relationships between pediments and alluvial fans in the western Flinders piedmont, contradict any suggestion that pediments are derived from fans by the selective evacuation of fines from the latter. The known age relations are inconsistent with such an interpretation, for the older alluvial fans are younger than the older pediments, and fans appear to succeed pediments in the evolutionary sequence.

*The riverine outwash plain is the basic initial form which can develop into either a covered pediment or an alluvial fan.* The latter is not feasible in all instances. For example, the Edeowie riverine outwash plain will not become an alluvial fan, because its catchment will continue to be confined to the arenaceous strata of the Wilpena Pound structure.

*The suite of alluvial fan deposits, including incipient, riverine outwash plain, minor and major, and the various positions of their fan apices within the pediment apron described from the Parachilna-Edeowie region seems to represent stages in the development of alluvial fans as they gradually replace the pediments laterally and headwards.*

In terms of the evolutionary model, *alluvial fan development is not triggered by tectonic, baselevel or by climatic change*, but is rather a reflection of the size and lithology of the drainage basin. Superimposed on and enhancing this evolutionary trend, however, are various "catastrophic" impacts, such as those due to tectonism, baselevel lowering, climatic changes, and meteorological storms, the latter resulting in dissection of previously developed flood plains veneered with coarse detritus.



## VII. CONCLUDING STATEMENT

The importance of catchment size and character is confirmed by the distribution of pediments and alluvial fans in the regional context. For example, in the eastern piedmont of the Flinders Ranges, the development of pediments and alluvial fans and their drainage basins by streams flowing to Lake Frome is comparable to that of the study area. In the Mid North of South Australia, pediments are associated with ranges of restricted area and extent, as in the Hummocks Ranges, near the head of Gulf St. Vincent. Further south only alluvial fans occur in the piedmont because the Mount Lofty Ranges are dominated by readily weathered strata. In addition, given the proximity of Gulf St Vincent, shifts in baselevel and sea level due to tectonism and climatic changes have facilitated the accumulation of alluvial deposits.

Looking further afield, in central and northern Australia, pediments are well and widely developed, but there are few, if any, alluvial fans. Uplands are either limited in area, like the MacDonnell or James ranges, or the uplands are dominated by arenaceous strata, e.g. Ooraminna, Hamersley and the Kakadu ranges. Even in granitic terrane, e.g. Everard Ranges, where the rock weathers to sand, there are no significant alluvial fans.

Similar correlations of pediments and fans with different size catchments are in evidence in other parts of the world. For example, in Nevada, north of McGill, Duck Creek has an extensive catchment of some 150 square kilometres. It is associated with a large fan-shaped landform in Steptoe Valley. Further north in the same valley, gently sloping rectilinear plains are dissected by streams draining catchments that are ten times smaller in Schell Creek Range. Again, the Cedar Creek Alluvial Fan, southeast of Ennis, Montana, is associated with a catchment which is considerably larger than those that are related to the pediments in the western piedmont of Madison Range.

In a review of the literature it was noted that Denny (1965, 1967) and Bull (1962a & b, 1964a & b, 1972, 1977), in particular, examined the relationship between catchment size and associated piedmont landforms. Denny remarked the importance of the geometry of

upland and plain, but in relation to a state of integration, rather than an evolution, of drainage:

*"large highlands and small lowlands favor complex fans where half the surface area may no longer receive sediment but be subject to erosion, whereas broad lowlands and small highlands favor extensive pediments"* (Denny, 1967, p.81).

Implicitly, Denny suggests that the pediments succeed alluvial fans, whereas the opposite is true in the Flinders Ranges. It is not the size of the uplands *per se* but rather the extent and character of the catchments, which leads to a change in stream action, and to pediments being succeeded by alluvial fans. Nevertheless, though neither Denny nor Bull made such a suggestion, the notion of a relationship between catchment and piedmont form prompted the idea of an evolutionary relationship as outlined in this study. In the western piedmont of the Flinders Ranges that relationship has been taken a step further in the proposed evolutionary scheme.

**APPENDIX I**

**THE IDENTIFICATION AND DISTRIBUTION OF PEDIMENTS AND ALLUVIAL  
FANS IN THE WESTERN PIEDMONT OF THE FLINDERS RANGES, SOUTH  
AUSTRALIA**

## APPENDIX I

### THE IDENTIFICATION AND DISTRIBUTION OF PEDIMENTS AND ALLUVIAL FANS IN THE WESTERN PIEDMONT OF THE FLINDERS RANGES, SOUTH AUSTRALIA

#### A. GENERAL STATEMENT

Pediments and alluvial fans occur in the western piedmont of the Flinders Ranges. As noted before, though the two landforms are genetically distinct, they are morphologically similar. Both are fan-shaped with the apex located at the scarp foot where a stream emerges from the upland. The surface appearance of the allochthonous material of a covered pediment is indistinguishable from that of an alluvial fan. Moreover, where alluvial fans have coalesced they form smooth aprons, which are not unlike merged covered pediments. It is difficult to differentiate or identify the forms.

In an attempt to distinguish pediments from alluvial fans in the study area, criteria based in remote sensing, geology and detailed morphology have been tested in relation to specific pediments and alluvial fans, the identity and character of which has been determined by field and borelog data. Reference is made to forms fringing the uplands of the study area, which are known to be covered pediment remnants. The contact between the smooth, cut, bedrock surfaces and its thin cover of allochthonous material has been exposed by creeks dissecting the surfaces and proven by digging trenches and by shallow seismic refraction survey. The alluvial fans mentioned are known to be underlain by wedges of alluvial deposits of considerable thickness, because borelog data is available for that part of the piedmont zone of the study area and there is some dissection of the forms.

## B. METHODS USED TO DISTINGUISH PEDIMENTS AND ALLUVIAL FANS

### 1. Thickness of the Alluvial Deposits

By definition, alluvial fans are formed by the build up of considerable thicknesses of sediments, whereas the pediment cover is relatively thin. But what is meant by 'considerable' and 'relative', by 'thick' and 'thin', in this context? Covered pediments are described as surfaces the morphology of which closely simulates that of the bedrock eroded beneath the cover. But this could apply equally to covers hundreds of metres or less than one metre in thickness. In most of the literature the thickness of an alluvial fan or a pediment cover is described without giving definitive measurements (e.g. Blackwelder, 1931; Blissenbach, 1954; Tuan, 1962). However, several workers have placed limits on the thickness of sediment underlying the surface of the form, in an attempt to distinguish a covered pediment from an alluvial fan.

Some have resorted to arbitrary but commonsense thicknesses. Doehring (1970), for instance, suggested that an alluvial veneer not exceeding 15.3 metres (50 feet) is the limiting factor for distinguishing between covered pediment and alluvial fan. Such a thickness of cover seems excessive in the context of the study area, where the pediment cover is typically of the order of 1-2 metres (Figures 3.11a & 3.21), and only 3-4 metres of alluvium underlie incipient alluvial fans.

Others have appealed to geometric ratios between the size of the forms and the thickness of the sedimentary cover. Bull (1977), for example, concluded that where the thickness of deposits is more than 1/100 the length of the landform, the form is an alluvial fan rather than a pediment. Applying this measurement in the study area, the Hayward Pediment, for example, has a 2 metre thick cover (see Chapter Three) and ought to be about 200 metres long. In reality it is about 2 500 metres in length and, according to Bull's ratio, could carry up to 25 metres of detritus and be regarded as a pediment. If the cover on the

Hayward Pediment were indeed 25 metres thick, then surely it ought no longer be described as a pediment?

For those who assumed the pediment cover is, or has been, in transit, the average depth of effective stream scour, that is the thickness of sediment worked by a particular stream in flood, is critical (e.g. Howard, 1942). The nature of the alluvial cover on the Hayward Pediment, for example, resembles that of the bedload in creeks dissecting the surface (Figure 3.11b) and its thickness, some 1-3 metres, is compatible with local maximum stream scour, e.g. that measured over a two year period in Brachina Creek (Figure 3.29). Some such measurement as depth of stream scour takes into account the local conditions. The definitive thickness of alluvial deposits between the covered pediment and the alluvial fan ought to be judged in each regional context. There can be no general case.

Several covered pediments occur in the study area and the base of the alluvial veneer is exposed in creek cuttings. The most widely developed pediment surface of the Parachilna-Edeowie sector of the western piedmont of the Flinders Ranges is covered by up to 2 metres of alluvium. On remnants of higher pediment surfaces the alluvial cover is mostly less than 1 metre thick. The relative thinness of this older pediment cover could be attributed to the evacuation of fines. The pediment remnants mapped in the piedmont of the Wyacca-Emeroo ranges also carry only a thin (1-2 metres) veneer of alluvium. Modern pediments bear a discontinuous cover of alluvium, mostly concentrated in abandoned stream channels. Minor landforms in the study area have been described variously as minor alluvial fans, riverine outwash plains and incipient alluvial fans and are considered distinct from the pediments on the bases of thickness of alluvial deposit and topographic situation. The absolute thickness of their deposits were not measured.

Nowhere in the western piedmont of the Flinders Ranges can the bedrock contact beneath the alluvial fans be observed. Thus information about the thickness of those deposits depends on borelog and geophysical evidence. Unfortunately most of the bores spudded in the study area were not logged. Even so their depth, in the range of 20-60 metres, drilled



entirely in alluvial material provides a minimum thickness for alluvial sediments beneath the fans and depositional plains. The few stratigraphic bores and drilling programmes, together with geophysical surveys, indicate considerable depths of Cainozoic sediments beneath the alluvial fans and plains of the study area (Figures 1.4 & 1.9, Table 1.1). In the Brachina Alluvial Fan, for example, 444 metres of Cainozoic alluvial and lacustrine sediments, including 50-60 metres of Quaternary fluvial deposits, over bedrock were logged from the Edeowie No.1 Stratigraphic Bore located some 10 kilometres west of the Flinders Ranges (Cockshell, 1983). Similar thicknesses of Tertiary and Quaternary sediments were interpreted from the BRA preliminary seismic survey line some 3 kilometres from the Brachina gorge mouth (D. Cockshell, 1992, pers. comm.). A minimum 140 metres of similar Cainozoic sediments were identified beneath the Parachilna Alluvial Fan (Anonymous, 1982; see also Figure 1.9).

Thus, field observations, corroborated by borelog data and shallow seismic survey, have established that pediment surfaces immediately adjacent to the upland carry a relatively thin cover of alluvium, of the order of a few metres. On the other hand, the thickness of deposits forming alluvial fans is measured in tens of metres.

## 2. Remote Sensing

Stereoscopic study of aerial photographs was augmented by the use of satellite imagery when mapping pediments and alluvial fans in the study area (Drury, 1987). Two scenes (1600 pixels, each pixel 30 metres square, and 750 lines) with seven bands of data were selected from Landsat 5 Thematic Mapper imagery dated December 1987. In the first, a known large alluvial fan dominates the piedmont zone east of Parachilna in approximately 31°10'S latitude (Figure AI.1a). The drainage basin with which it is associated is developed in the Blinman Dome structure in the centre of the Flinders Ranges. Pediments, and a minor alluvial fan associated with Five Mile Creek, occur at the foot of the upland (see also Figure 4.7). In the second scene, Wilkatana North and Wilkatana South creeks, with their drainage basins within the Wyacca Range, have deposited alluvial fans in

approximately 32°10'S latitude (Figure AI.2a). Remnants of the pediment surface fringe the upland.

False colours of rock-soil and vegetation associations emphasise the various lithologies involved in the folded structures of the Flinders Ranges. In addition, within the piedmont plains, contrasting colours readily distinguish the prominent alluvial fans from the pediment surfaces with their relatively thin cover of alluvium. Using the band ratios specified in these examples (Figures AI.1a & AI.2a), the alluvial fans are predominantly purple/light blue for non-vegetated active areas, green/mustard yellow for inactive areas, and red/brown for vegetated channels and secondary fans. White, mustard yellow and mid-green indicate the pediments, with vegetation in stream lines appearing red to brown. The application of a different set of band ratios provides a more startling colour contrast to distinguish covered pediments from alluvial fans (Figure AI.1b & AI.2b). Satellite imagery is a useful, even critical, tool for mapping such an assemblage of landforms.

### 3. Contour Pattern

Several authors have noted that contours parallel to the scarp are likely to indicate thinly veneered pediments, whereas those bowing downslope denote alluvial fans (e.g. Denny, 1965). To test this suggestion, generalised contours, after the style of Pannekoek (1970), have been drawn for the piedmont plains of the study area (Figures AI.3 & AI.4). Smoothing and generalising the contour lines eliminate distracting irregularities due to structure and dissection. In broad view, contour lines run parallel to the range front of the Heysen Range, where covered pediment surfaces are known to occur. Similarly, parallel contour lines distinguish the pediment remnants surviving in interfan areas within the piedmont of the Wyacca-Emeroo ranges. This pattern differs from those bowing downslope on the large alluvial fans of the western piedmont of the Flinders Ranges.

The largest fan-shaped features, known to be alluvial fans, are clearly delineated by the contour pattern on all published topographic maps, even at the 1:250 000 scale with a

## APPENDIX I

contour interval of 50 metres. Those in the Heysen Range piedmont each cover an area of more than 127 square kilometres and their deposits are spread some 20 kilometres from the upland. Those in the Wyacca-Emeroo ranges piedmont are less extensive, but no less obvious, covering areas of 13-44 square kilometres and forming an alluvial apron 7-9 kilometres wide. Thus, contour pattern is a useful criterion for identifying large alluvial fans.

At the foot of the Emeroo Range in the interfan area between Deep and Mundallio alluvial fans, contours bowing downslope within a pattern of more or less parallel contour lines define a minor alluvial fan, called here Ukat and related to an otherwise unnamed stream, deposited on the covered pediment apron fronting the upland. However, in the Parachilna-Edeowie sector of the Heysen Range piedmont, arcuate contour lines outline what are, on the field evidence, covered pediment fans as well as minor alluvial fans and riverine outwash plains inset within the erosional surface. The length of these pediments and minor alluvial fans, measured from scarp foot to toe, is 3-4 kilometres, i.e. approximately half that of the alluvial fans mapped further south in the piedmont of the Wyacca-Emeroo ranges. This situation demonstrates that the contour pattern method is a less reliable criterion for distinguishing alluvial fans and pediments at small scale, particularly when the two forms are of similar dimensions.

Where, however, alluvial fans have coalesced to form alluvial aprons, Ruhe (1964) noted that the contour pattern is not unlike that of a pediment apron, i.e. the contours parallel the mountain front. North of the Wilkatana North Alluvial Fan a very narrow, covered pediment contiguous with the backing scarp and with bedrock only 2 metres beneath the surface occurs at the foot of the Wyacca Range, beyond which lies an alluvial apron (Figure 3.31). However, neither the transition from pediment to alluvial deposits, nor the depositional nature of the piedmont plains, finds expression in the contour pattern, which essentially parallels the scarp.

Contour pattern is useful for distinguishing large scale features, but proved unreliable at small scale and, in particular, where alluvial fans and pediment cones are of similar dimensions.

#### 4. Drainage Texture

From his consideration of a number of large pediments and alluvial fans Doehring stated that "*drainage texture on pediments tends to become finer in a headward direction but remains relatively constant on alluvial fans*" (Doehring, 1970, p.3111). In other words, pediments tend to have numerous quite short channels incised in their upper slopes (Figures AI.5a & b), a fact noted by earlier workers, e.g. Bryan (1922, 1936a) and Gilluly (1937), whereas channels are the most obvious features of alluvial fan surfaces (Figure AI.5c). Doehring (1970) analysed several identified pediments and alluvial fans by regressing the number of fluvial channels, expressed as contour crenulations, on a number of contours. He called the least squares linear regression lines thus calculated, texture curves. He worked with large scale landforms and reported a perfect correlation between field observation and their texture curves.

The method was effective for very few pediment surfaces in the study area (Figures AI.6 & AI.7, Tables AI.1 & AI.2). Sample strips, which include at least ten contour line segments of equal lengths, could only be applied to the most extensive pediments, all of which are in the Parachilna-Brachina section of the Heysen Range piedmont, viz. Barregowa, Bundulla and Hayward pediments (Figure AI.6, 4, 5, 6 *in* Figure AI.8, Table AI.2). The texture curve slopes, derived by Doehring (1970) for pediments, range from 0.38 to 3.73, and were generally applicable in the study area, although that for Hayward Pediment did not fit, and neither did the covered pediment sector of Aliena Washout (13 Aliena East, *in* Figure AI.8, Table AI.2). However, texture curve analysis for the upslope contour segments of the Hayward Pediment (Figure AI.6, 8 Hayward East, *in* Figure AI.8, Table AI.2) was within the range of pediment values. Consideration of a significant set of values downslope (Figure AI.6, 7 Hayward West, *in* Figure AI.9, Table AI.2), indicated

Table AI.1 Count of Contour Crenulations for Texture Curve Analysis.

	SAMPLE STRIP NAME	NUMBER OF OBSERVATIONS/ NUMBERED CONTOUR LINES															
		1	2	3	4	5	6	7	8	9	10	11	12	13	14	15	16
1	Parachilna WNW Fan	4	4	5	5	4	4	5	4	6	7						
2	Parachilna WSW Fan	3	5	7	7	4	5	7	8	10	8						
3	Five Mile Fan	7	8	7	6	6	7	11	9	12	11	10	10	10			
4	Barregowa Pediment	5	7	5	5	6	7	4	7	8	12						
5	Bundulla Pediment	5	6	7	6	5	5	7	8	8	10						
6	Hayward Pediment	5	7	3	7	7	6	7	5	6	7	7	7	10	11	9	
7	Hayward West	5	7	3	7	7	6	7	5	6	7						
8	Hayward East	6	7	5	6	7	7	7	10	11	9						
9	Brachina	5	6	6	2	3	2	5	5	6	3						
10	Bunyeroo	4	7	5	5	7	6	6	5	6	5						
11	Aliena Washout	11	9	8	12	9	9	10	9	9	8	10	8	9	12	11	10
12	Aliena West	11	9	8	12	9	9	10	9	9	8						
13	Aliena East	10	9	9	8	10	8	9	12	11	10						
14	Yadlamalka	3	3	6	5	6	4	5	6	5	5						
15	Wilkatana North Fan	6	5	5	4	5	4	4	5	4	5						
16	Wilkatana South Fan	6	5	4	3	4	5	4	5	5	4						
17	Depot Fan	3	4	3	4	3	3	4	4	3	3						
18	Thompson Fan	3	5	6	7	5	6	6	6	7	6						
19	Dry South Fan	3	4	5	6	5	5	7	7	6	5						
20	South Fan	5	7	7	8	5	7	6	7	7	8						
21	Deep Fan	4	4	5	3	4	6	6	3	7	5						
22	Ukat Fan	5	7	6	6	10	10	5	4	4	5						

that the feature was there an 'alluvial fan'. Whether this truly reflects that the pediment cover has so thickened downslope that the intrinsic nature of the landform has changed cannot be tested at this time.

The range of values for alluvial fans, -0.22 to 0.26 (Doehring, 1970) were applied to large scale alluvial fans in the Parachilna-Edeowie region. Their texture curve slopes are consistent with their being alluvial fans (Figures AI.6 & AI.9, Tables AI.1 & AI.2). The nine sections tested in the Wyacca-Emeroo piedmont, Yadlamalka Fan through Ukat Fan, also fit within the alluvial fan texture curve range (Figures AI.7 & AI.9; Table AI.1 & AI.2).

Limitations of the method, similar to those noted by Doehring (1970), were encountered in the study area. Some of the features, known to be pediments, e.g. pediment remnants in the piedmont of the Wyacca-Emeroo ranges with a cover of alluvium less than 2 metres thick, are areally too small for the method to be applied satisfactorily. Analysis of others, where the sample strip includes unequal length contour segments, i.e. upper slopes where contours have too short a radius of curvature, proved inconclusive, e.g. Five Mile Fan (Figure AI.6, 3 *in* Figure AI.8). An erroneous result was also obtained for the 'Parachilna WSW Fan' sample strip, because it was partly drawn over portion of the Parachilna Alluvial Fan which has numerous minor channels (Figure AI.6, 2 *in* Figure AI.8). For the method to work, sample strips must be drawn across one drainage texture domain and in this instance it included more than one. On the other hand, the sample strip for Aliena Washout coincides with one drainage texture domain, i.e. the main braided stream (Figure AI.6). The texture curve slope is consistent with those of alluvial fans (11 *in* Figure AI.9), although Aliena Washout is known to be a complex feature (see Chapter Five).

Drainage texture analysis can only be applied where the sample strip includes a significant number of contour lines, i.e. at least ten. Given the available topographic coverage and with due consideration of other limitations, the method is reliable only for large scale features.

## 5. Catchment Characteristics

Analysis of the catchments related to pediments and alluvial fans identified on field or borelog evidence, together with the criteria mentioned above, demonstrates two contrasted characteristics (Figure 5.1). First, the size of the catchment varies, those serving pediments being smaller than those associated with alluvial fans. Second, and in large measure a function of the areal extent of the drainage basin, those catchments related to pediments are characteristically developed largely in the quartzites, sandstones and limestones that form the front ramparts of the western Flinders Ranges, whereas those serving alluvial fans have extended beyond the margin of the upland into argillaceous terrains.

In the Parachilna-Edeowie region streams with drainage basins less than 3.35 square kilometres in area, average 2.41 square kilometres, have eroded pediments with a cover of 1-3 metres thick. The degree of dissection of the surface and the thickness of the pediment cover are affected when streams further enlarge their catchments. Increased discharge causes the stream to cut down more effectively into the pediment surface. The increase in size of catchment results in an increased supply of sediment. Braided streams, which have eroded catchments in the resistant rocks at least 3 square kilometres in area, deposit thicker spreads of coarse alluvium, referred to as riverine outwash plains, e.g. drainage basins 3, 4, 27 and 28 (Figures 3.20 & 5.1; Table 3.1). The supply of sediment has increased, but the type has not changed.

Where a drainage basin has extended beyond the limestone and quartzite ridges to include less resistant shales and siltstones of sequences older than Rawnsley Quartzite, then the stream deposits minor alluvial fans, e.g. drainage basins 5, 8, 10, and (marginally) 7, 13, and 14 (Figures 3.20 & 5.1; Table 3.1). The supply of sediment has increased and the type has changed.

## APPENDIX I

Catchments of major through streams, like Parachilna and Brachina-Bunyeroo, were presumably restricted in size and located within the western ridges of the Flinders Ranges, when they eroded their pediments. These are relic forms for their streams are incised 30-40 metres below the level of the main pediment. Those streams have since headed back, via faulted zones, through the Heysen Range and captured drainage basins with areas of the order of hundreds of square kilometres. The sheer increase in size of these drainage basins, coupled with the inclusion of a greater proportion of argillite susceptible to weathering and erosion, ensured the deposition of major alluvial fans. This suggested sequence of events differs only in terms of scale from that described for riverine outwash plains and minor alluvial fans. The scale difference may, in part, be accounted for by the duration of time: given time, and, if conditions are conducive, a riverine outwash plain becomes a minor alluvial fan, and eventually a major alluvial fan. However, for these larger forms, tectonism and possibly climatic effects have accentuated the fundamental change from erosional to depositional behaviour by streams in the study area.

In the Wyacca-Emeroo region there is a clear distinction between the size of drainage basins related to pediments and those associated with alluvial fans (Figure 5.1). Streams with drainage basins less than 2.41 square kilometres in area have eroded the pediment. The average sizes of catchments related to pediments in the three sectors of the Wyacca-Emeroo region are considerably less than 2.41km<sup>2</sup>, viz. 0.54km<sup>2</sup> in the Wyacca Range, 0.24km<sup>2</sup> in the Central Section and 0.46km<sup>2</sup> in Emeroo Range (Figure 3.37, Table 3.3). Their drainage basins are restricted to the resistant quartzite and dolomite strata of the western escarpment of the Flinders Ranges. On the other hand, streams, which headed back via faulted zones through the resistant front ridges of the Wyacca-Emeroo ranges into less resistant argillite, have deposited major alluvial fans. Their catchments are at least three times larger than those serving the pediments. They vary in size from 6.38 to 39.51 square kilometres.

Pediments are associated with small catchments restricted to arenaceous and carbonate strata, which disintegrate to produce coarse blocky detritus. Alluvial fans are deposited by



streams which have enlarged their catchments into argillaceous sediments, which break down readily to fine grained silt and clay.

## 6. Length

The length, measured normal to the upland front, of major alluvial fans and pediments is apparently a distinguishing characteristic in the study area. The Parachilna and Brachina-Bunyeroo alluvial fans are almost 20 kilometres long, whereas the covered pediment apron is mostly of the order of 3-4 kilometres in length. In like manner, the alluvial fans deposited in the piedmont of the Wyacca-Emeroo ranges are 6-10 kilometres long, but the well dissected, covered pediment surface extends less than 650 metres from the scarp foot.

Some of the toeslopes of the pediment surfaces are truncated by known faults, or at least terminate in a dissected linear low scarp. Otherwise the lower pediment slopes are buried in alluvial deposits, contributed by streams incised in the surface, and the exact position of the toeslopes is unknown. Regression analyses (Draper & Smith, 1967) showed that the lengths of major and minor alluvial fans are related to the area and length of their respective drainage basins, but those of pediments are not (Appendix II). Thus, the superficial impression that length might be used to judge between alluvial fans and pediments proved untenable for the study area. Nevertheless, it is offered as a possible criterion for other regions. Alluvial fan deposits, which are not restricted by topography, spread over extensive areas of a piedmont, whereas pediments are fringing forms. Indeed Twidale (1983a) suggested that with increasing distance from the upland the nature of a pediment surface acquires many of the characteristics of the peneplain (see also Mabbutt, 1978).

## 7. Other Criteria

There are several other criteria mentioned in the literature which were not rigorously tested in the study area but are worthy of note.

## (a) Bedrock Hills and Ridges

Locally, bedrock residuals in the form of ridges and peaks stand within bevelled pediment surfaces (e.g. Tuan, 1959; Hunt & Mabey, 1966). Remnants of the high pediment surfaces in the study area are surrounded by the main pediment surface cut in the same steeply dipping bedrock and thinly covered by alluvial detritus (Figure 3.21). However, inliers like Mount Fort Bowen and Mount Brown, for example, appear to be similar features. But they stand amid alluvial deposits of the Carpentaria Basin, which are some 200 metres thick (Doutch *et al.*, 1970). On the other hand, Bull (1977) refers to bedrock knobs protruding through the pediment cover, but not occurring on alluvial fan surfaces. Presumably these are small features. They may resemble the weathering *in situ* of some of the largest sandstone boulders in the pediment cover of the study area (Figure 3.12a), but no similarly weathered blocks were noticed in alluvial fan deposits.

## (b) Slope

Blackwelder (1931) and Bull (1977) noted that the gradients of alluvial fans are steeper than those of pediments. The range of slopes for each landform, i.e.  $\frac{1}{2}^{\circ}$ - $7^{\circ}$  for pediments and  $\frac{1}{2}^{\circ}$ - $10^{\circ}$  for alluvial fans, allows the possibility. However, in the study area the opposite proved true. Pediments are consistently relatively steeper than the alluvial fans with which they coexist.

## (c) Relief Amplitude and/or Highest Points in Drainage Basin

Denny (1965, 1967) observed that 'large' uplands favoured the development of alluvial fans and 'small' highlands were associated with pediments (see also Melton, 1965a). In the Parachilna-Edeowie region the highest points in the drainage basins associated with the erosion of pediments average 767m above present sea level. They are lower than the highest points in drainage basins related to the deposition of alluvial fans. High points in catchments draining to minor alluvial fans average 802m, and those of catchments draining

to major alluvial fans average 847m (Figure 4.2a). A similar relationship was noted in the Wyacca-Emeroo region (Figure 4.2b).

(d) Ruggedness of Drainage Basin

The ruggedness of a drainage basin is expressed as a mathematical relationship between measurements in drainage basins of relief amplitude and of area (Melton, 1965a). Therefore, there is a relationship between ruggedness and the preceding section. In the Parachilna-Edeowie region, for example, the relative relief, or ruggedness, ratio of drainage basins associated with pediments averages 0.285. This value is greater than the average ruggedness ratio for basins related to either major alluvial fans, which is 0.035, or minor alluvial fans, which is 0.228 (Table 4.4).

(e) Granulometric Measurement of Surface Deposits

The alluvial inputs to covered pediments consist of comparatively small volumes of coarse debris, in contrast with the large volumes of predominantly fine grained detritus deposited in the alluvial fans. Pediment cover consists of bedload deposits of the streams which have eroded the bedrock surface. The coarse debris of the pediments becomes relatively coarser as fines are washed out of the dissected pediment cover. However, there is a mixture of smaller calibre material let down into the deposit, as is seen in the dry channels of the local episodically flowing streams, and a matrix of sand and silt derived from the weathering of the cover material or washed in during flood events.

On the other hand, the nature of alluvial fan deposition is too variable to ascribe one surface type as typical. Alluvial fans may be a mixture of, or wholly composed of, fluvial deposits, coarse debris flow deposits, sieve deposits, or a series of mudflows. In the study area, for example, alluvial fan deposits include lenses of coarse material of fluvial and colluvial origin within beds of silt and sand. The fines of the larger catchments are mixed

with coarser materials derived in part from the extended catchments (for though dominated by argillite there are minor outcrops of limestone and sandstone, for example).

C. CONCLUDING STATEMENT

Of these criteria thickness and texture of the alluvial deposit, remote sensing imagery and catchment characteristics provide the best means of identification of pediments and alluvial fans in the study area. Others such as contour pattern and drainage density are viable for extensive, but not for small-scale examples or minor remnants of the forms. They provide supportive but not conclusive data.

**APPENDIX II**

**REGRESSION ANALYSIS: CHARACTERISTICS OF PEDIMENTS & ALLUVIAL  
FANS**

## APPENDIX II

### REGRESSION ANALYSIS: CHARACTERISTICS OF PEDIMENTS & ALLUVIAL FANS

Regression Analysis performed using 'MINITAB'(c) statistics package.

TESTING NULL HYPOTHESIS THAT THERE IS NO RELATIONSHIP BETWEEN THE TWO VARIABLES.

If  $P = < 0.05$  null hypothesis is REJECTED and it is accepted that there is a relationship between the two variables tested.

If  $P = > 0.05$  null hypothesis is RETAINED and it is accepted that there is no relationship between the two variables tested

N.B. The piedmont landforms associated with Aliena and Edeowie creeks are regarded as exceptional (see Chapter Five). They are not included in the observations tested. Nor is the 'minor alluvial fan', which appears to be associated with Walkandi tributary drainage system (14 *in* Figure 3.20), included. Walkandi tributary once flowed westward across the pediment surface and deposited an alluvial fan (Figure 4.10). However, on emerging from the upland, the present stream flows southwest to join Walkandi Creek. The minor alluvial fan is disconnected from its drainage basin. Therefore, the characteristics of the piedmont form are related to an older, smaller catchment.

## PEDIMENTS

## OBSERVATIONS (Figure 3.20, Table 3.1)

ROW	C1	C2	C3	C4	C5
1	1.15	324	0.060698	1.5	2.0
2	1.02	308	0.008600	1.8	2.0
3	1.23	290	0.089905	0.8	2.0
4	1.56	515	0.193125	2.0	2.2
5	1.52	525	0.181844	2.0	2.6
6	2.84	540	0.453318	2.5	0.8
7	3.35	328	0.525045	2.0	4.0
8	2.44	305	0.387390	1.5	3.6
9	1.98	333	0.296665	1.8	2.4
10	1.21	333	0.082785	1.8	2.4
11	2.51	420	0.399674	1.8	2.4

## 'PEDIMENT'

1	(6) Barregowa North
2	(11) Bundulla tributary
3	(12) Bundulla tributary
4	(15) Walkandi
5	(16) Hayward
6	(18) Ilina South
7	(21) Brachina tributary
8	(22) Bunyeroo tributary
9	(24) Unnamed
10	(25) Unnamed
11	(26) Unnamed

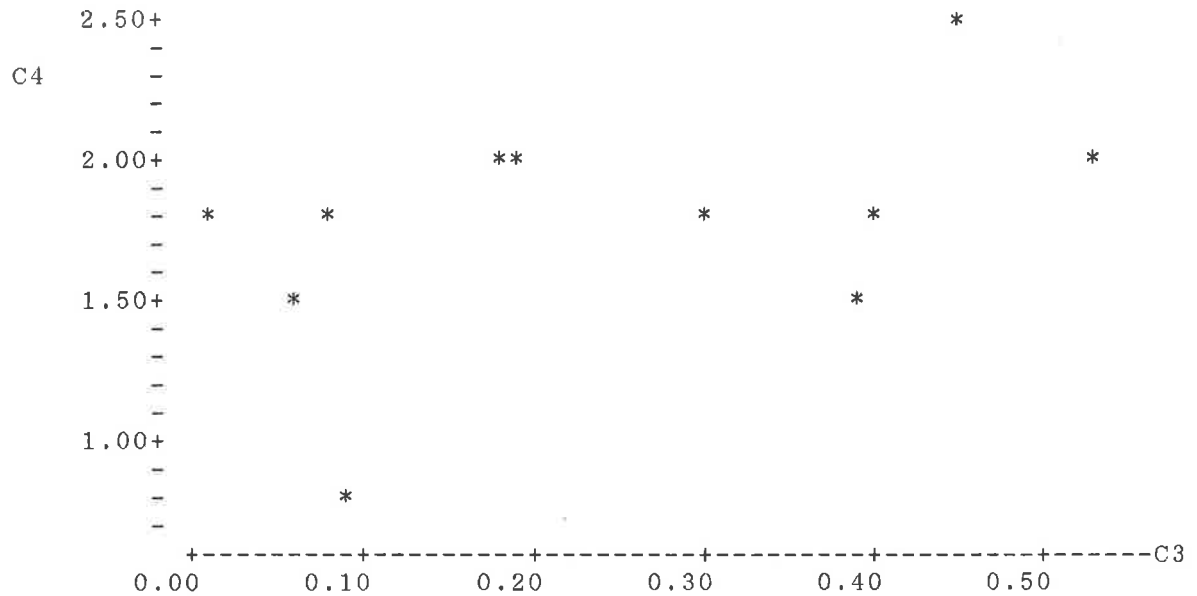
## COLUMNS

C1	(BA)	Basin Area
C2	BH	Basin High Point
C3	BA	logten(BA)
C4	BL	Basin Length
C5	PL	Pediment Length

## LIST OF REGRESSION ANALYSES &amp; TEST RESULTS FOR 'PEDIMENT'

1.	c4 on c3	BL on BA	Null hypothesis RETAINED
2.	c5 on c3	PL on BA	Null hypothesis RETAINED
3.	c5 on c4	PL on BL	Null hypothesis RETAINED
4.	c5 on c2	PL on BH	Null hypothesis RETAINED

MTB > plot c4 c3



MTB >

MTB > regr c4 1 c3

The regression equation is  
 $C4 = 1.51 + 1.10 C3$

Predictor	Coef	Stdev	t-ratio
Constant	1.5056	0.2085	7.22
C3	1.0966	0.7027	1.56

s = 0.3947      R-sq = 21.3%      R-sq(adj) = 12.6%

Analysis of Variance

SOURCE	DF	SS	MS	F	p
Regression	1	0.3795	0.3795	2.436	.1530
Error	9	1.4023	0.1558		
Total	10	1.7818			

Unusual Observations

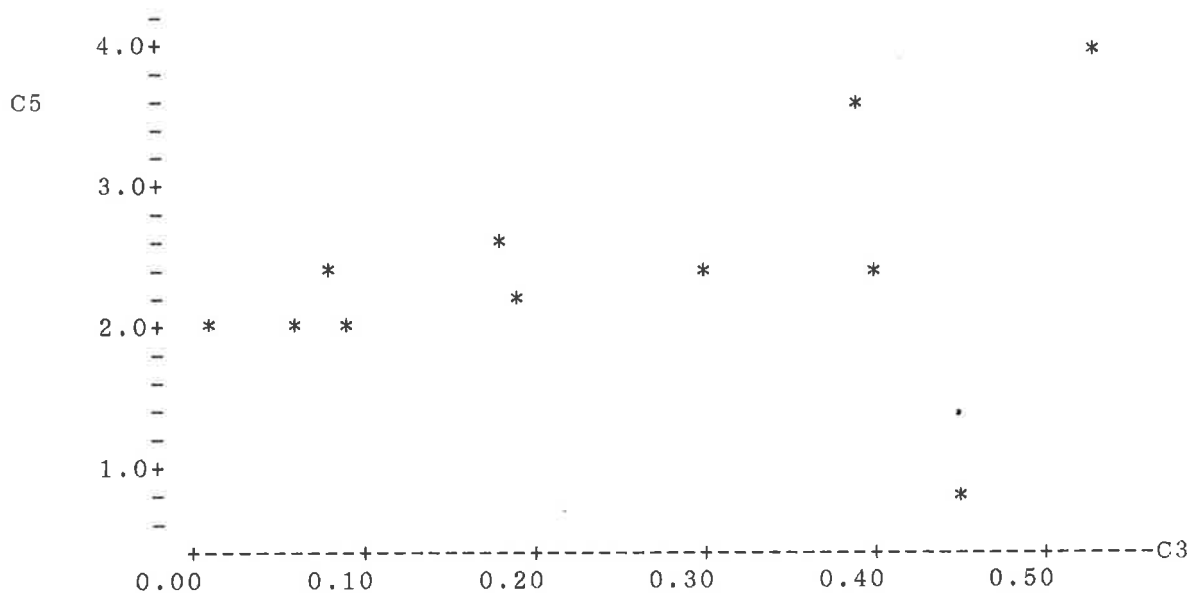
Obs.	C3	C4	Fit	Stdev.Fit	Residual	St.Resid
3	0.090	0.800	1.604	0.161	-0.804	-2.23R

R denotes an obs. with a large st. resid.

MTB >



MTB > plot c5 c3



MTB >

MTB > regr c5 1 c3

The regression equation is  
 $C5 = 2.00 + 1.63 C3$

Predictor	Coef	Stdev	t-ratio
Constant	2.0035	0.4413	4.54
C3	1.628	1.487	1.09

s = 0.8356      R-sq = 11.7%      R-sq(adj) = 1.9%

Analysis of Variance

SOURCE	DF	SS	MS	F	p
Regression	1	0.8362	0.8362	1.198	.3022
Error	9	6.2838	0.6982		
Total	10	7.1200			

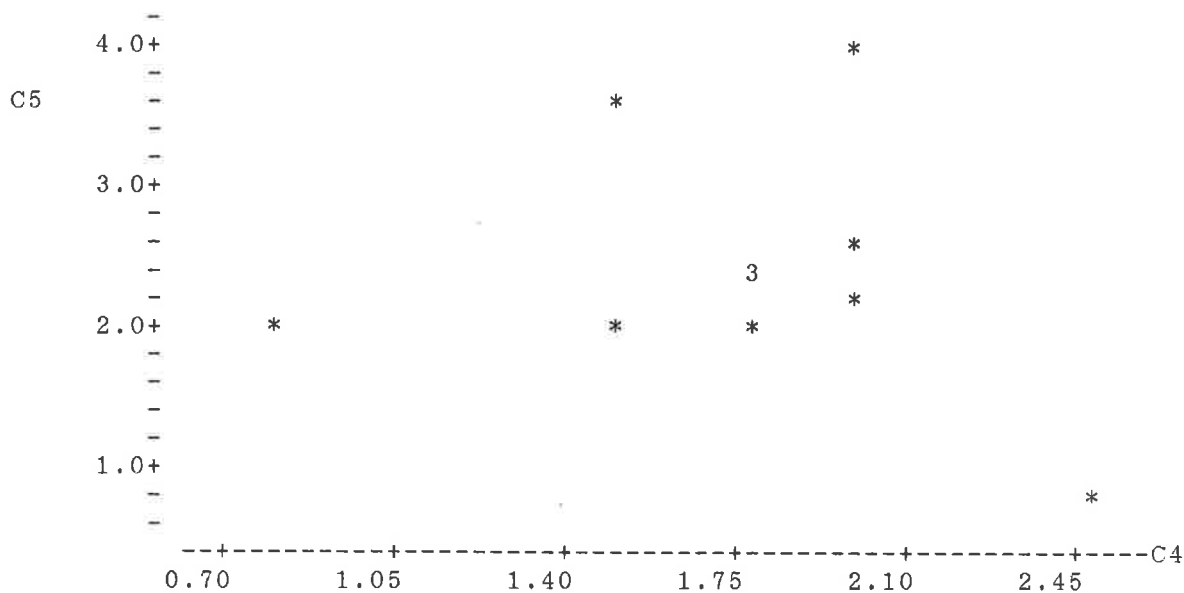
Unusual Observations

Obs.	C3	C5	Fit	Stdev.Fit	Residual	St.Resid
6	0.453	0.800	2.741	0.401	-1.941	-2.65R

R denotes an obs. with a large st. resid.

MTB >

MTB > plot c5 c4



MTB >

The regression equation is  
C5 = 3.04 - 0.359 C4

Predictor	Coef	Stdev	t-ratio
Constant	3.037	1.192	2.55
C4	-0.3592	0.6555	-0.55

s = 0.8750      R-sq = 3.2%      R-sq(adj) = 0.0%

Analysis of Variance

SOURCE	DF	SS	MS	F	p
Regression	1	0.2299	0.2299	0.3003	.5970
Error	9	6.8901	0.7656		
Total	10	7.1200			

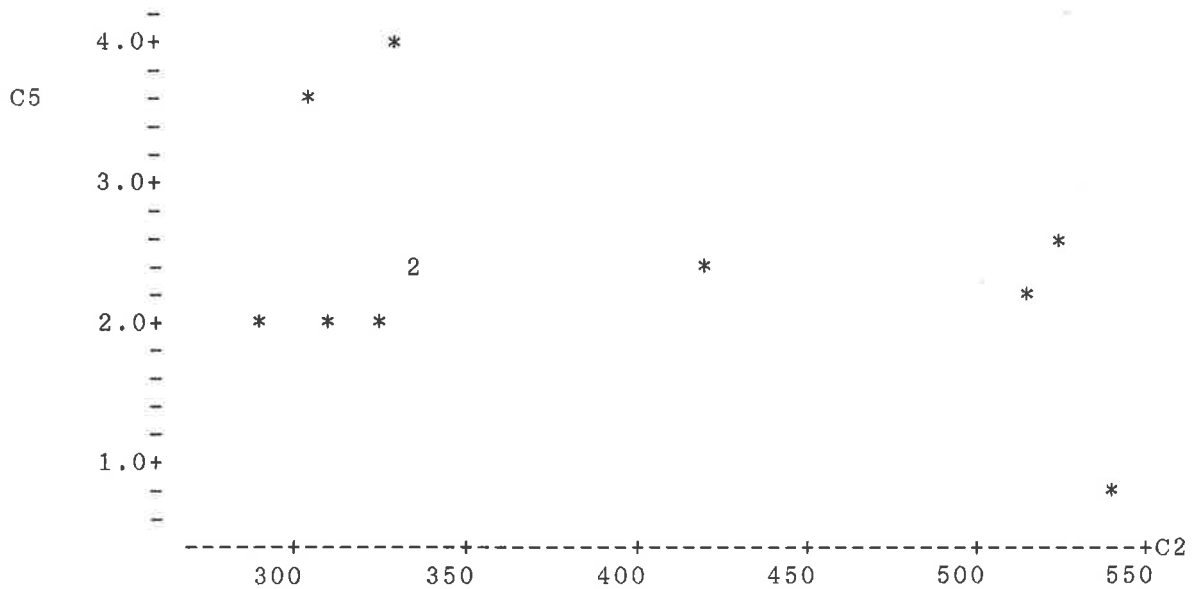
Unusual Observations

Obs.	C4	C5	Fit	Stdev.Fit	Residual	St.Resid
3	0.80	2.000	2.749	0.690	-0.749	-1.39 X
7	2.00	4.000	2.318	0.303	1.682	2.05R

R denotes an obs. with a large st. resid.  
X denotes an obs. whose X value gives it large influence.

MTB >

MTB > plot c5 c2



MTB >

MTB > regr c5 1 c2

The regression equation is  
C5 = 3.77 - 0.00356 C2

Predictor	Coef	Stdev	t-ratio
Constant	3.767	1.036	3.64
C2	-0.003562	0.002623	-1.36

s = 0.8103      R-sq = 17.0%      R-sq(adj) = 7.8%

Analysis of Variance

SOURCE	DF	SS	MS	F	p
Regression	1	1.2109	1.2109	1.844	.2075
Error	9	5.9091	0.6566		
Total	10	7.1200			

MTB >

MTB >

MTB >

MTB >

## MAJOR ALLUVIAL FANS

OBSERVATIONS (see Figure 4.3, Table 4.1)

ROW	C1	C2	C3	C4	C5	C6	C7
1	0.3274	599.00	567	-0.484921	2.77743	21.50	17.5
2	0.3317	350.00	615	-0.479255	2.54407	21.00	19.0
3	0.3707	127.00	561	-0.430977	2.10380	13.00	17.0
4	1.6366	16.41	574	0.213943	1.21511	4.50	7.0
5	1.8505	6.38	538	0.267289	0.80482	3.50	6.5
6	0.9548	39.51	644	-0.020088	1.59671	10.00	9.0
7	1.2131	13.05	440	0.083897	1.11561	4.00	8.5
8	1.6366	7.14	597	0.213943	0.85370	4.25	7.0
9	1.5548	11.58	600	0.191675	1.06371	4.75	7.0
10	2.0363	11.73	630	0.308842	1.06930	4.00	4.5
11	0.8594	32.10	619	-0.065805	1.50651	10.00	8.0

## 'MAJORFAN'

1	Parachilna
2	Brachina
3	Bunyeroo
4	Wilkatana North
5	Wilkatana South
6	Depot
7	Thompson
8	Dry South
9	South
10	Deep
11	Mundallio

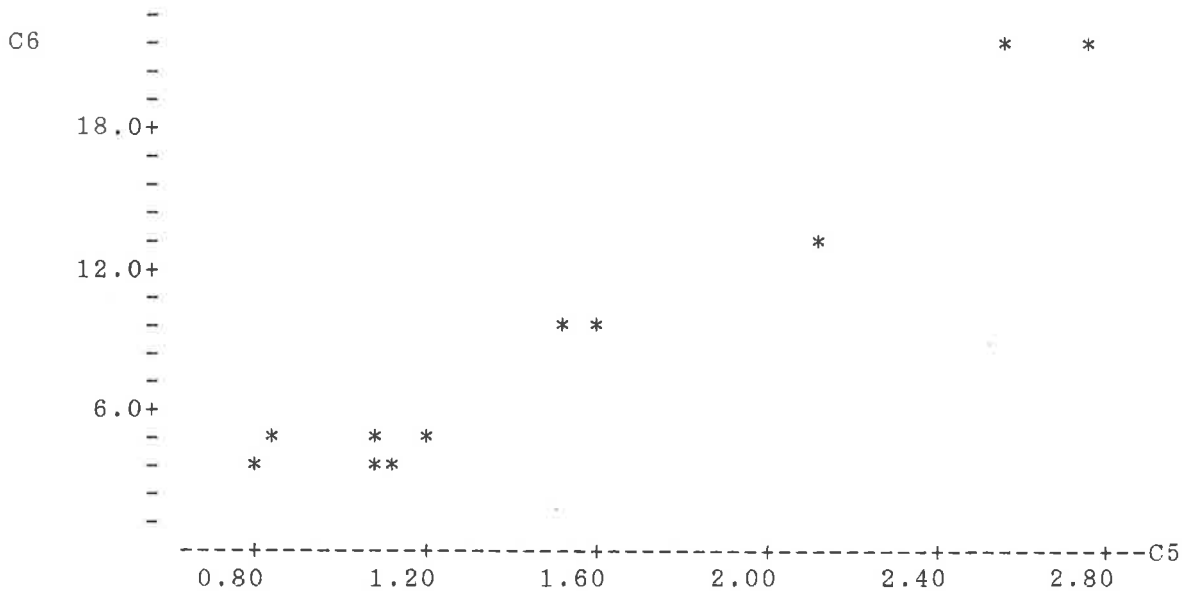
## COLUMNS

C1	(FS)	Fan Slope
C2	(BA)	Basin Area
C3	BH	Basin High Point
C4	FS	logten(FS)
C5	BA	logten(BA)
C6	BL	Basin Length
C7	FL	Fan Length

## LIST OF REGRESSION ANALYSES FOR 'MAJORFAN'

1.	c6 on c5	BL on BA	Null hypothesis REJECTED
2.	c7 on c5	FL on BA	Null hypothesis REJECTED
3.	c7 on c6	FL on BL	Null hypothesis REJECTED
4.	c7 on c3	FL on BH	Null hypothesis RETAINED
5.	c7 on c4	FL on FS	Null hypothesis REJECTED
6.	c5 on c4	BA on FS	Null hypothesis REJECTED

MTB > plot c6 c5



MTB >

MTB > regr c6 1 c5

The regression equation is  
C6 = - 5.71 + 9.81 C5

Predictor	Coef	Stdev	t-ratio
Constant	-5.706	1.054	-5.42
C5	9.8052	0.6401	15.32

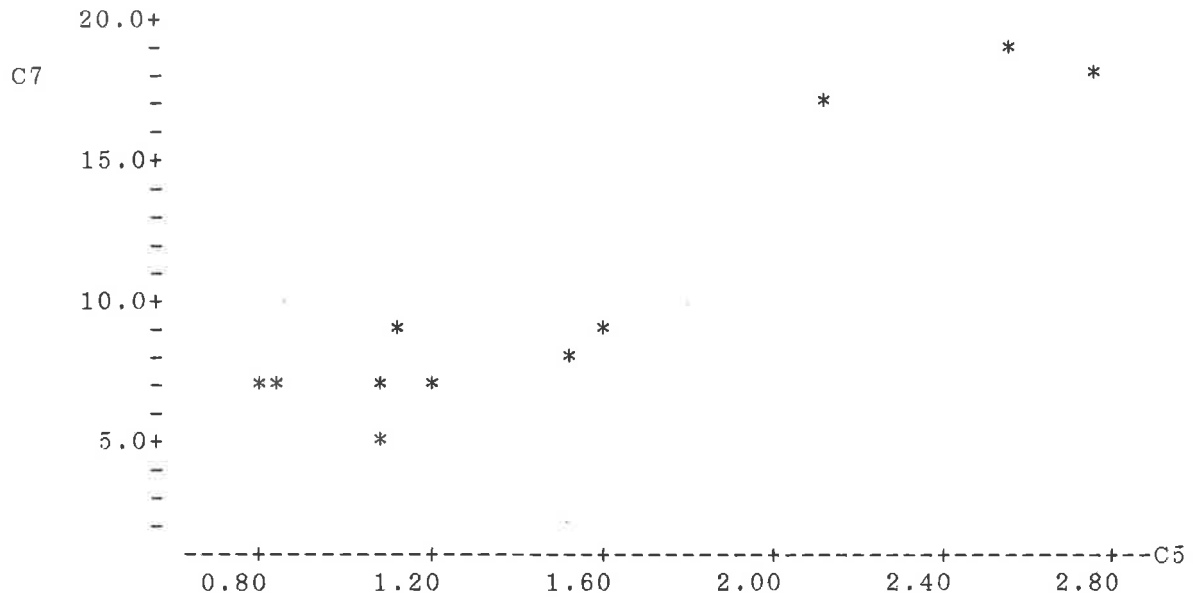
s = 1.373      R-sq = 96.3%      R-sq(adj) = 95.9%

Analysis of Variance

SOURCE	DF	SS	MS	F	p
Regression	1	442.21	442.21	235.2	0.0000
Error	9	16.96	1.88		
Total	10	459.17			

MTB >  
MTB >  
MTB >  
MTB >

MTB > plot c7 c5



MTB >

MTB > regr c7 1 c5

The regression equation is  
C7 = - 0.63 + 7.08 C5

Predictor	Coef	Stdev	t-ratio
Constant	-0.625	1.456	-0.43
C5	7.0793	0.8847	8.00

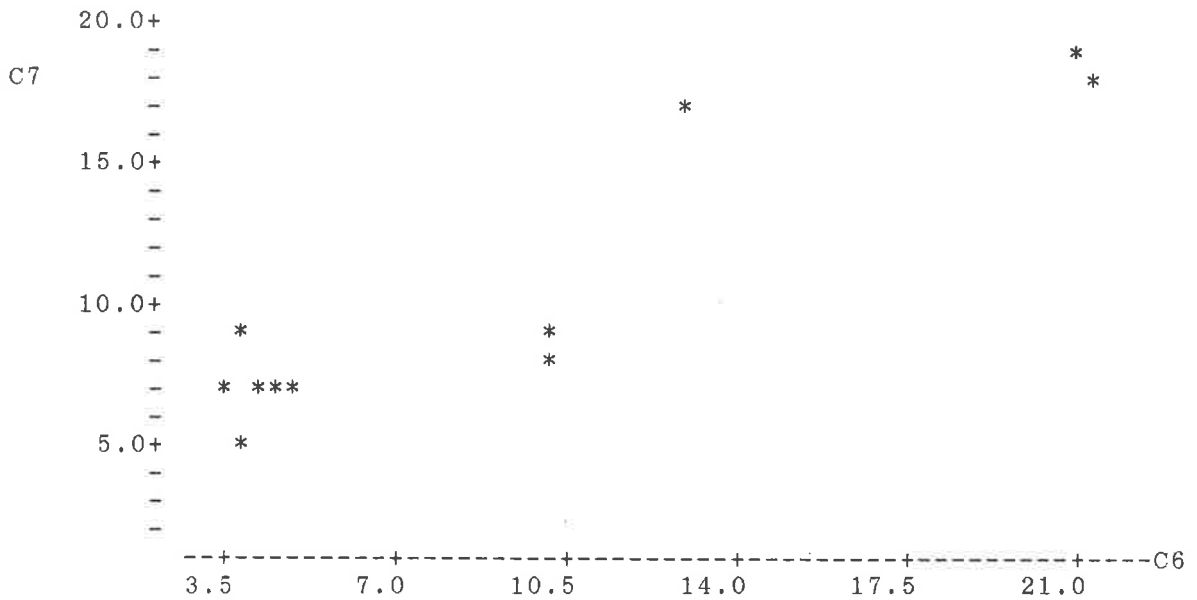
s = 1.897      R-sq = 87.7%      R-sq(adj) = 86.3%

Analysis of Variance

SOURCE	DF	SS	MS	F	p
Regression	1	230.51	230.51	64.03	0.0000
Error	9	32.40	3.60		
Total	10	262.91			

MTB >  
MTB >  
MTB >  
MTB >

MTB > plot c7 c6



MTB >

MTB > regr c7 1 c6

The regression equation is  
 $C7 = 3.70 + 0.700 C6$

Predictor	Coef	Stdev	t-ratio
Constant	3.697	1.073	3.45
C6	0.69988	0.09588	7.30

s = 2.055      R-sq = 85.5%      R-sq(adj) = 83.9%

Analysis of Variance

SOURCE	DF	SS	MS	F	P
Regression	1	224.92	224.92	53.29	0.0000
Error	9	37.99	4.22		
Total	10	262.91			

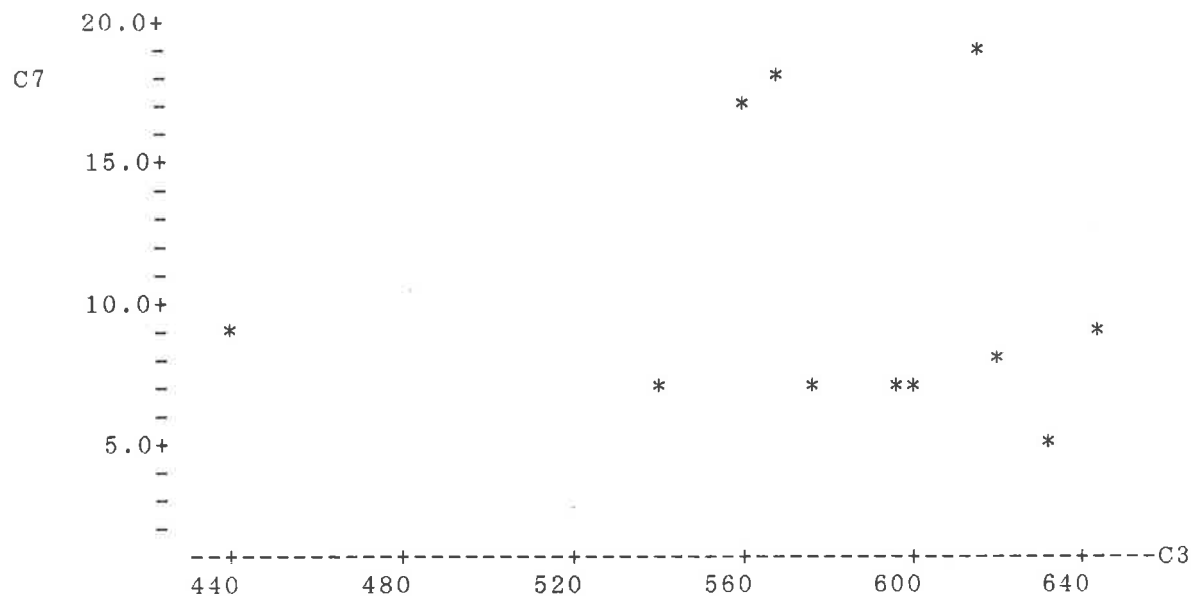
Unusual Observations

Obs.	C6	C7	Fit	Stdev.Fit	Residual	St.Resid
3	13.0	17.000	12.795	0.722	4.205	2.19R

R denotes an obs. with a large st. resid.

MTB >

MTB > plot c7 c3



MTB >

MTB > regr c7 1 c3

The regression equation is  
C7 = 11.3 - 0.0022 C3

Predictor	Coef	Stdev	t-ratio
Constant	11.34	17.62	0.64
C3	-0.00216	0.03022	-0.07

s = 5.403      R-sq = 0.1%      R-sq(adj) = 0.0%

Analysis of Variance

SOURCE	DF	SS	MS	F	p
Regression	1	0.15	0.15	0.0051	0.9444
Error	9	262.76	29.20		
Total	10	262.91			

Unusual Observations

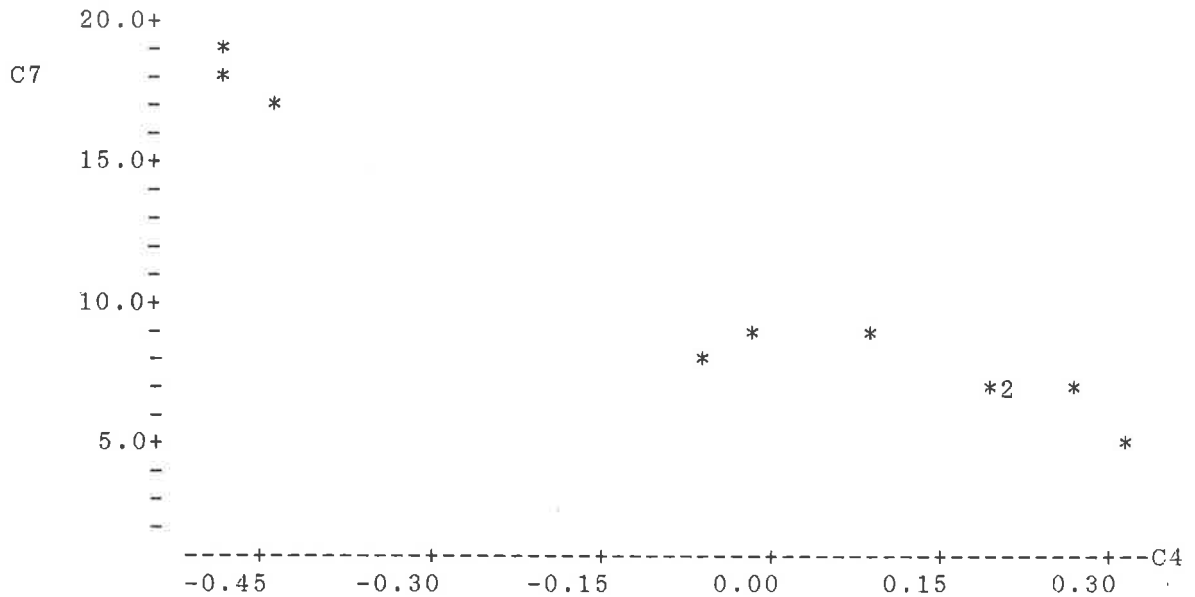
Obs.	C3	C7	Fit	Stdev.Fit	Residual	St.Resid
7	440	8.50	10.39	4.55	-1.89	-0.65 X

X denotes an obs. whose X value gives it large influence.

MTB >



MTB > plot c7 c4



MTB >

MTB > regr c7 1 c4

The regression equation is  
C7 = 9.79 - 16.2 C4

Predictor	Coef	Stdev	t-ratio
Constant	9.7949	0.3733	26.24
C4	-16.163	1.265	-12.77

s = 1.236      R-sq = 94.8%      R-sq(adj) = 94.2%

Analysis of Variance

SOURCE	DF	SS	MS	F	p
Regression	1	249.16	249.16	162.2	0.0000
Error	9	13.75	1.53		
Total	10	262.91			

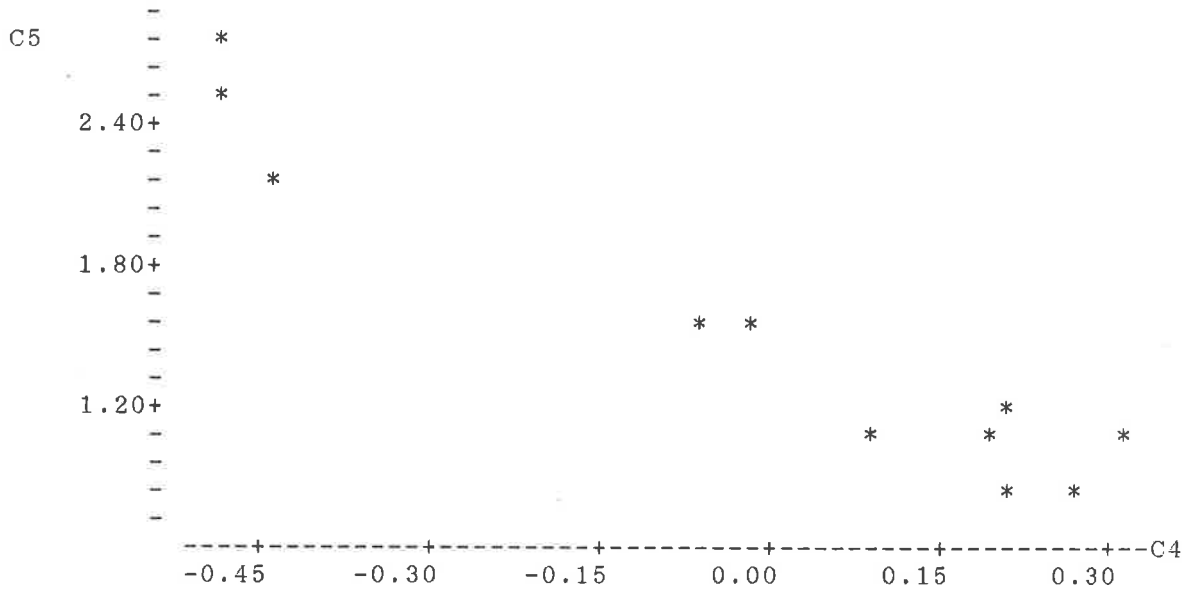
Unusual Observations

Obs.	C4	C7	Fit	Stdev.Fit	Residual	St.Resid
11	-0.066	8.000	10.858	0.377	-2.858	-2.43R

R denotes an obs. with a large st. resid.

MTB >

MTB > plot c5 c4



MTB >

MTB > regr c5 1 c4

The regression equation is  
C5 = 1.48 - 2.11 C4

Predictor	Coef	Stdev	t-ratio
Constant	1.47504	0.05944	24.81
C4	-2.1112	0.2015	-10.48

s = 0.1968      R-sq = 92.4%      R-sq(adj) = 91.6%

Analysis of Variance

SOURCE	DF	SS	MS	F	p
Regression	1	4.2511	4.2511	109.8	0.0000
Error	9	0.3485	0.0387		
Total	10	4.5996			

MTB >  
MTB >  
MTB >  
MTB >

## MINOR ALLUVIAL FANS

## OBSERVATIONS (Figure 3.20, Table 4.4)

ROW	C1	C2	C3	C4	C5	C6	C7
1	1.5	9.13	517	0.176091	0.960471	3.8	3.6
2	1.9	3.41	397	0.278754	0.532754	2.0	2.4
3	1.8	4.61	450	0.255273	0.663701	3.3	3.2
4	1.7	5.04	504	0.230449	0.702431	3.8	3.2
5	2.1	3.75	408	0.322219	0.574031	2.8	2.4
6	2.3	2.94	534	0.361728	0.468347	2.3	1.6

## 'MINORFAN'

1	(5) Five Mile
2	(7) Barregowa South
3	(8) Tea Cosy
4	(10) Bathtub
5	(13) Bundulla
6	(17) Ilina North

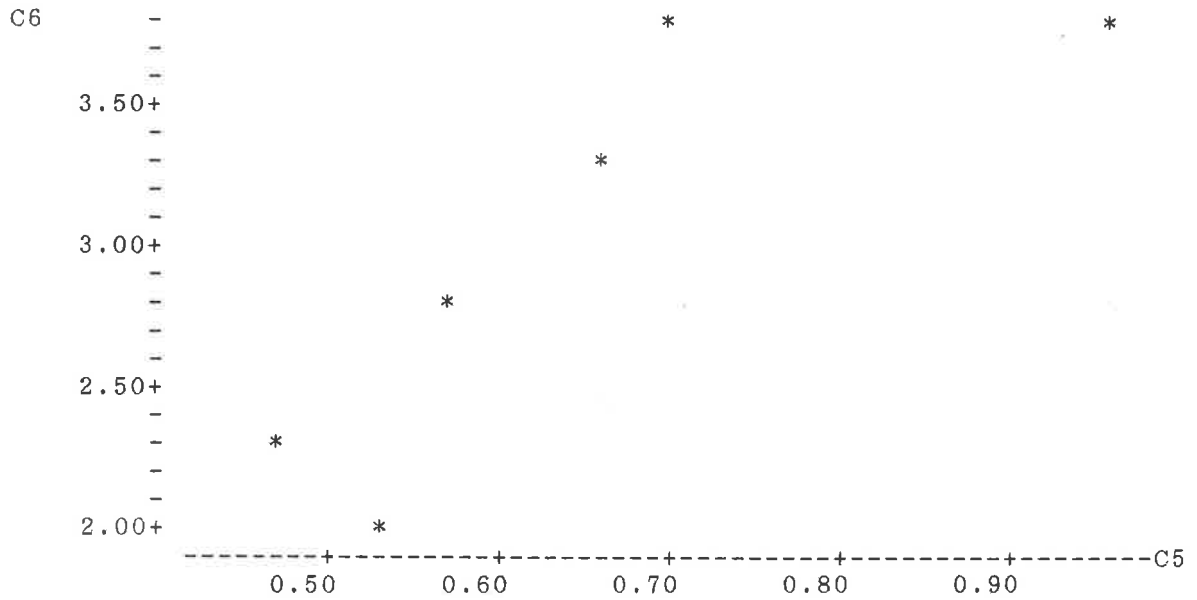
## COLUMNS

C1	(FS)	Fan Slope
C2	(BA)	Basin Area
C3	BH	Basin High Point
C4	FS	logten(FS)
C5	BA	logten(BA)
C6	BL	Basin Length
C7	FL	Fan Length

## LIST OF REGRESSION ANALYSES &amp; TEST RESULTS FOR 'MINORFAN'

1.	c6 on c5	BL on BA	Null hypothesis REJECTED
2.	c7 on c5	FL on BA	Null hypothesis REJECTED
3.	c7 on c6	FL on BL	Null hypothesis REJECTED
4.	c7 on c3	FL on BH	Null hypothesis RETAINED
5.	c7 on c4	FL on FS	Null hypothesis REJECTED
6.	c5 on c4	BA on FS	Null hypothesis REJECTED

MTB > plot c6 c5



MTB >

MTB > regr c6 1 c5

The regression equation is  
C6 = 0.627 + 3.65 C5

Predictor	Coef	Stdev	t-ratio
Constant	0.6273	0.8052	0.78
C5	3.649	1.203	3.03

s = 0.4687      R-sq = 69.7%      R-sq(adj) = 62.1%

Analysis of Variance

SOURCE	DF	SS	MS	F	p
Regression	1	2.0215	2.0215	9.205	.0386
Error	4	0.8785	0.2196		
Total	5	2.9000			

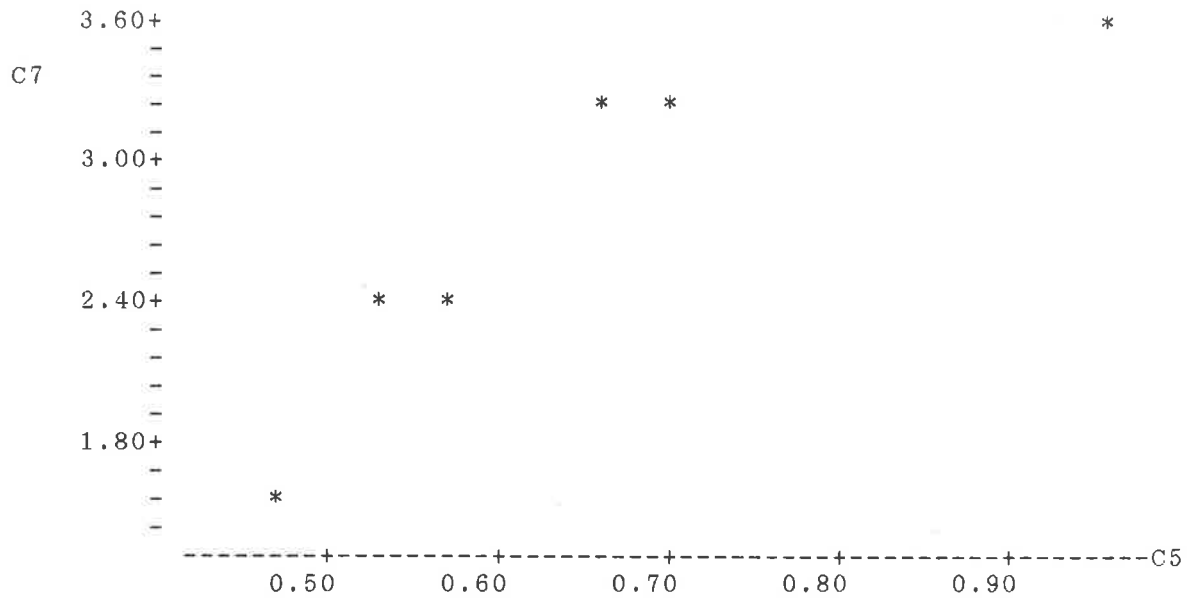
MTB >

MTB >

MTB >

MTB >

MTB > plot c7 c5



MTB >

MTB > regr c7 1 c5

The regression equation is  
C7 = 0.291 + 3.76 C5

Predictor	Coef	Stdev	t-ratio
Constant	0.2913	0.6382	0.46
C5	3.7553	0.9533	3.94

s = 0.3715      R-sq = 79.5%      R-sq(adj) = 74.4%

Analysis of Variance

SOURCE	DF	SS	MS	F	p
Regression	1	2.1413	2.1413	15.51	.0170
Error	4	0.5520	0.1380		
Total	5	2.6933			

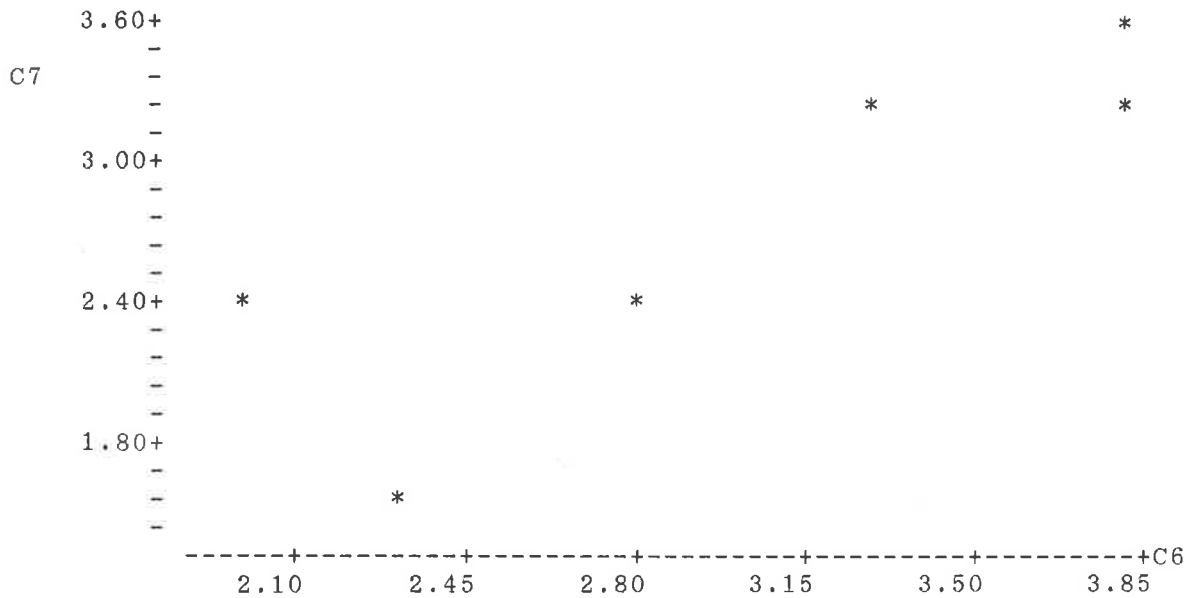
MTB >

MTB >

MTB >

MTB >

MTB > plot c7 c6



MTB >

MTB > regr c7 1 c6

The regression equation is  
 $C7 = 0.251 + 0.828 C6$

Predictor	Coef	Stdev	t-ratio
Constant	0.2506	0.7603	0.33
C6	0.8276	0.2469	3.35

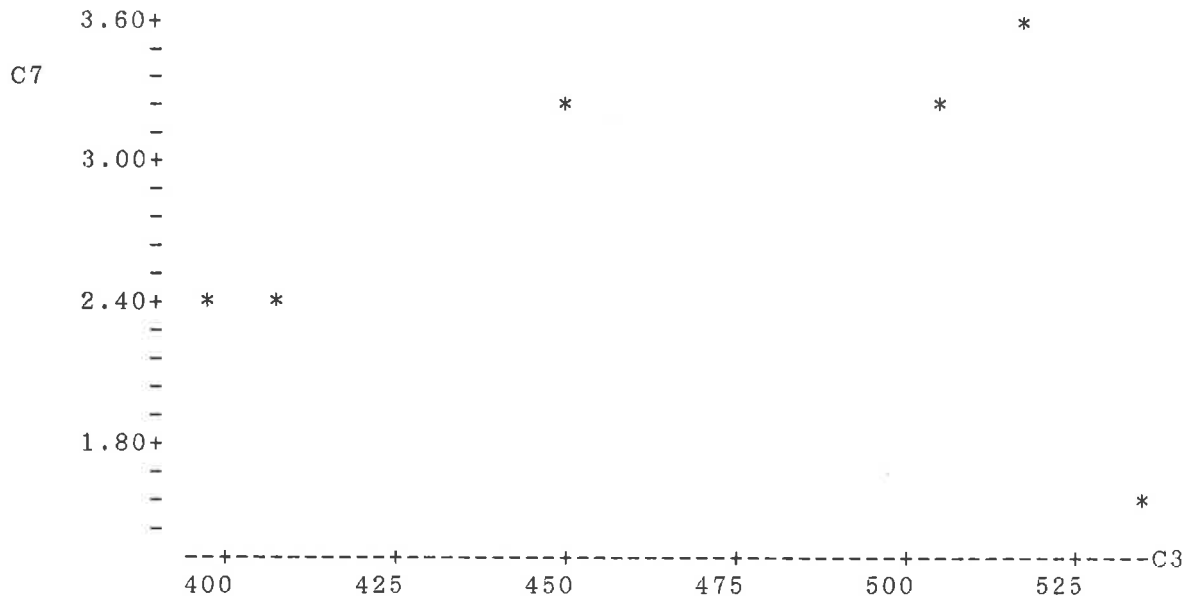
s = 0.4205      R-sq = 73.7%      R-sq(adj) = 67.2%

Analysis of Variance

SOURCE	DF	SS	MS	F	p
Regression	1	1.9862	1.9862	11.23	.0285
Error	4	0.7071	0.1768		
Total	5	2.6933			

MTB >  
MTB >  
MTB >  
MTB >

MTB > plot c7 c3



MTB >

MTB > regr c7 1 c3

The regression equation is  
 $C7 = 2.19 + 0.00116 C3$

Predictor	Coef	Stdev	t-ratio
Constant	2.190	2.952	0.74
C3	0.001160	0.006263	0.19

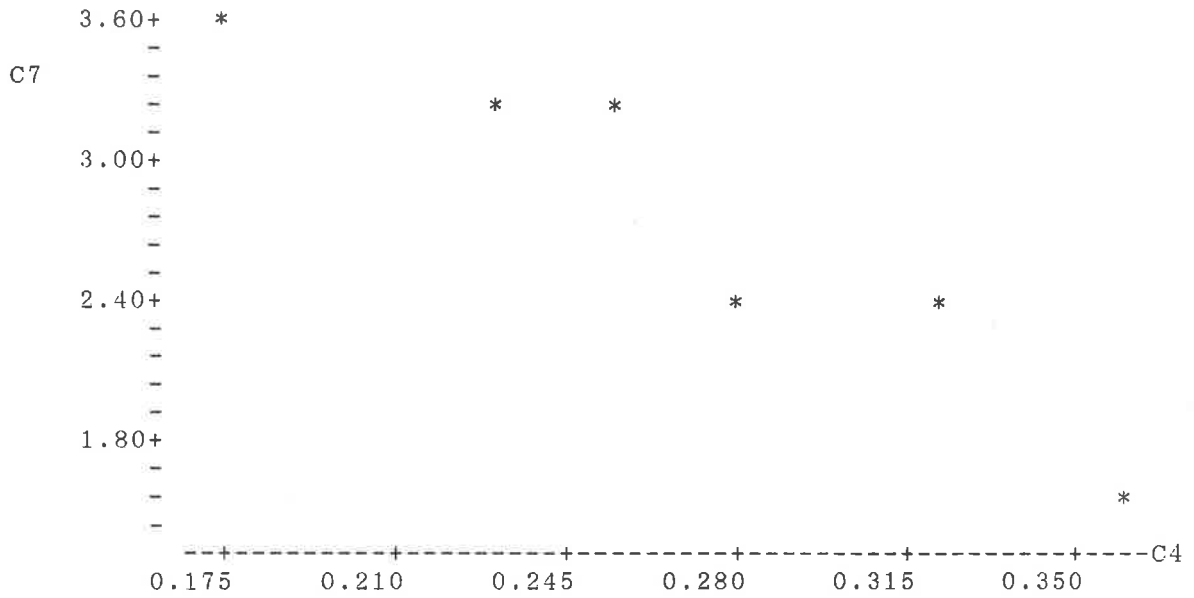
s = 0.8171      R-sq = 0.8%      R-sq(adj) = 0.0%

Analysis of Variance

SOURCE	DF	SS	MS	F	p
Regression	1	0.0229	0.0229	.0376	.8557
Error	4	2.6705	0.6676		
Total	5	2.6933			

MTB >  
MTB >  
MTB >  
MTB >

MTB > plot c7 c4



MTB >

MTB > regr c7 1 c4

The regression equation is  
C7 = 5.60 - 10.6 C4

Predictor	Coef	Stdev	t-ratio
Constant	5.6005	0.4668	12.00
C4	-10.589	1.683	-6.29

s = 0.2486      R-sq = 90.8%      R-sq(adj) = 88.5%

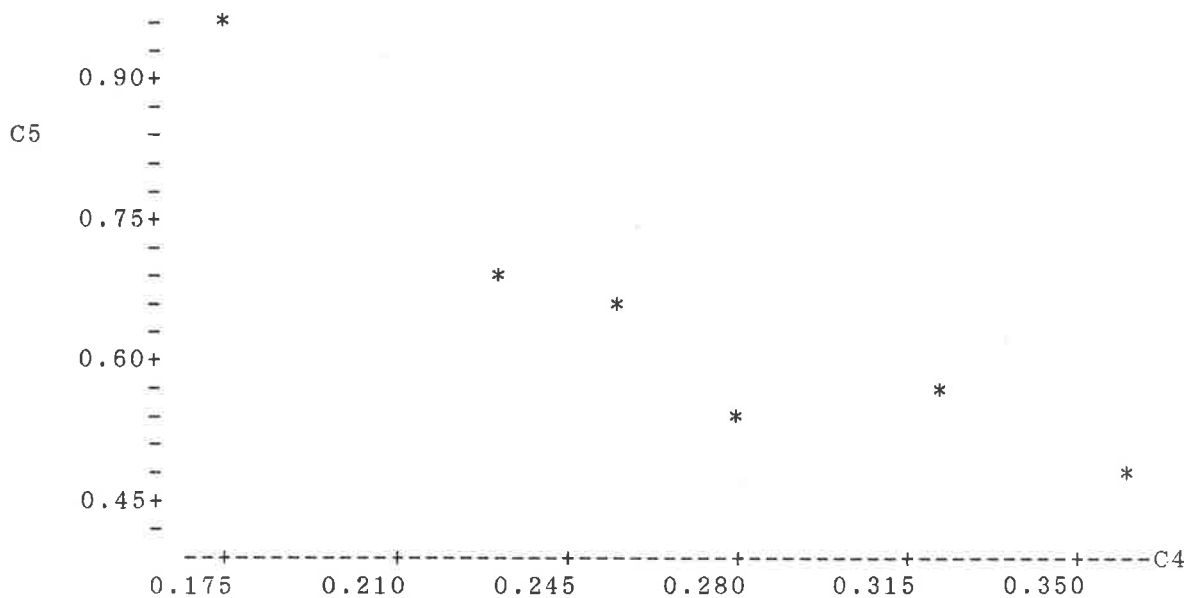
Analysis of Variance

SOURCE	DF	SS	MS	F	p
Regression	1	2.4462	2.4462	39.58	.0033
Error	4	0.2472	0.0618		
Total	5	2.6933			

MTB >  
MTB >  
MTB >  
MTB >



MTB > plot c5 c4



MTB >

MTB > regr c5 1 c4

The regression equation is  
C5 = 1.31 - 2.43 C4

Predictor	Coef	Stdev	t-ratio
Constant	1.3092	0.1413	9.27
C4	-2.4337	0.5094	-4.78

s = 0.07524      R-sq = 85.1%      R-sq(adj) = 81.4%

Analysis of Variance

SOURCE	DF	SS	MS	F	p
Regression	1	0.12920	0.12920	22.82	.0088
Error	4	0.02264	0.00566		
Total	5	0.15184			

MTB >  
MTB >  
MTB >  
MTB >

**APPENDIX III**

**SHALLOW SEISMIC REFRACTION SURVEY: HAYWARD PEDIMENT**

## APPENDIX III

### SHALLOW SEISMIC REFRACTION SURVEY: HAYWARD PEDIMENT

29-30 April, 1994.

Team led by Dr. R. Hillis\* and M. Ruttly (Flinders University of South Australia) assisted by S. Squire\* and J. A. Bourne\*.

\*(Department of Geology & Geophysics, University of Adelaide)

#### EQUIPMENT

24 geophones, 23 metre line, outtake cable connected to seismograph (Bison Digital Instantaneous Floating Point Signal Stacking Seismograph) and computer, hammer and plate.

Equipment on loan, by kind permission of Professor S. A. Greenhalgh, Earth Sciences Department, Flinders University of South Australia.

*Grid references:* 1:50,000 Topographic Series, map sheet 6635-3 *Oraparinna*, Department of Environment and Natural Resources, South Australia.

**TEST SITE:** G.R. TL651333, slope 6°, bearing 230°.

Line 30 metres in from stream line and section exposed in bank (Figure 3.11a). Alluvial gravels, including sandstone, quartzite, limestone, 1-2.5 metres over steeply dipping (50°W), Billy Creek Formation red-brown, micaceous sandstones and shales.

#### METHOD

Shots from either end and centre of geophone spread. Offset shots at 12 and 24 metres (too much additional noise with latter) at either end for confirmation re refractive layers.

#### ILLUSTRATION

Series of computer print-outs for test site on following pages:

2000.su Test shot. Station 0.

2001.su Test shot. Station 0.

2002.su Stacking Test. Station 0.

2003.su Downslope shot. Station 25.

2004.su Stack of above. Station 25.

2005.su Single blow. Station 25.

2006.su Single blow. Station 25.

2007.su Midspread. Station 12.5.

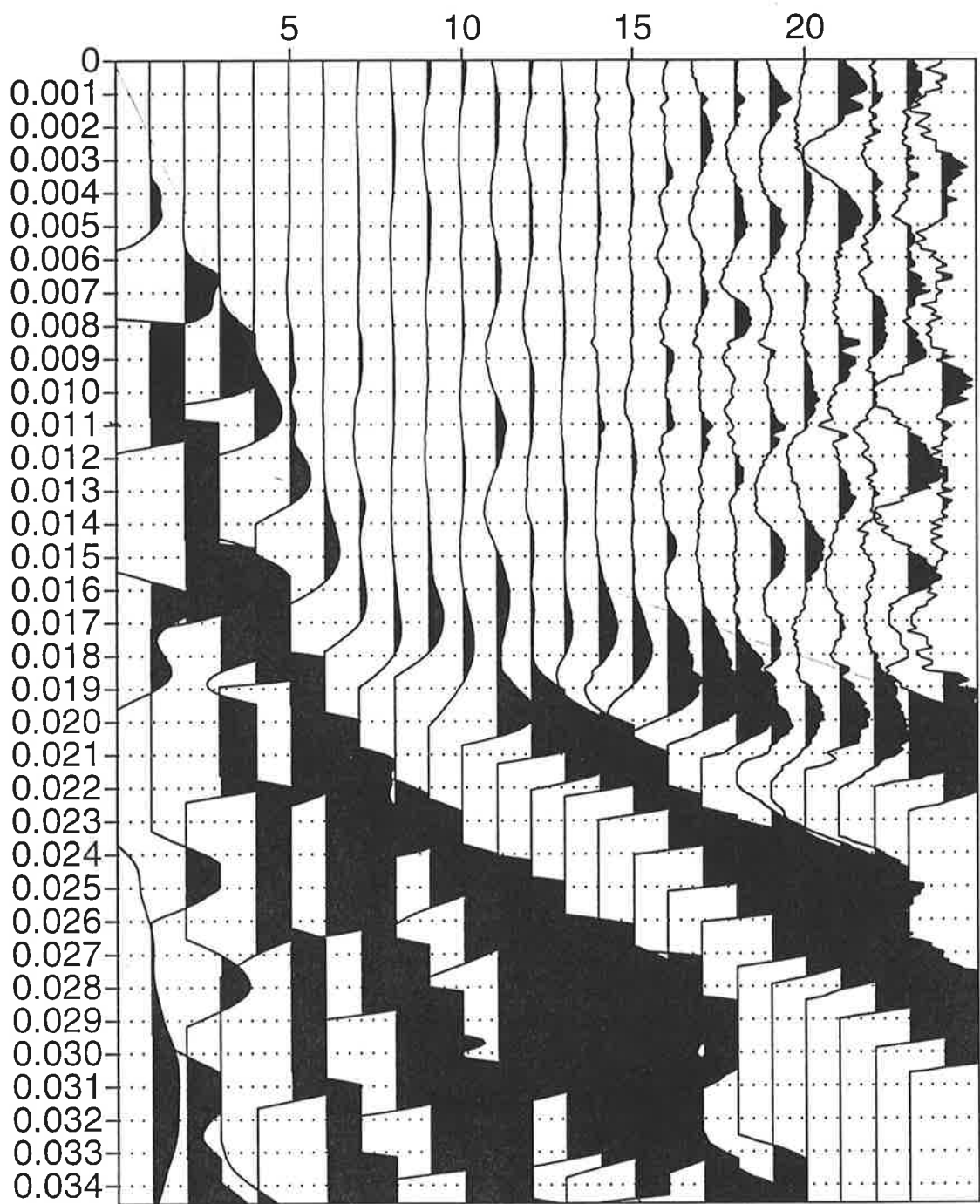
2010.su 12 metres offset from Stn 1. Station -11.

2011.su 12 metres offset from Stn 24. Station 36.

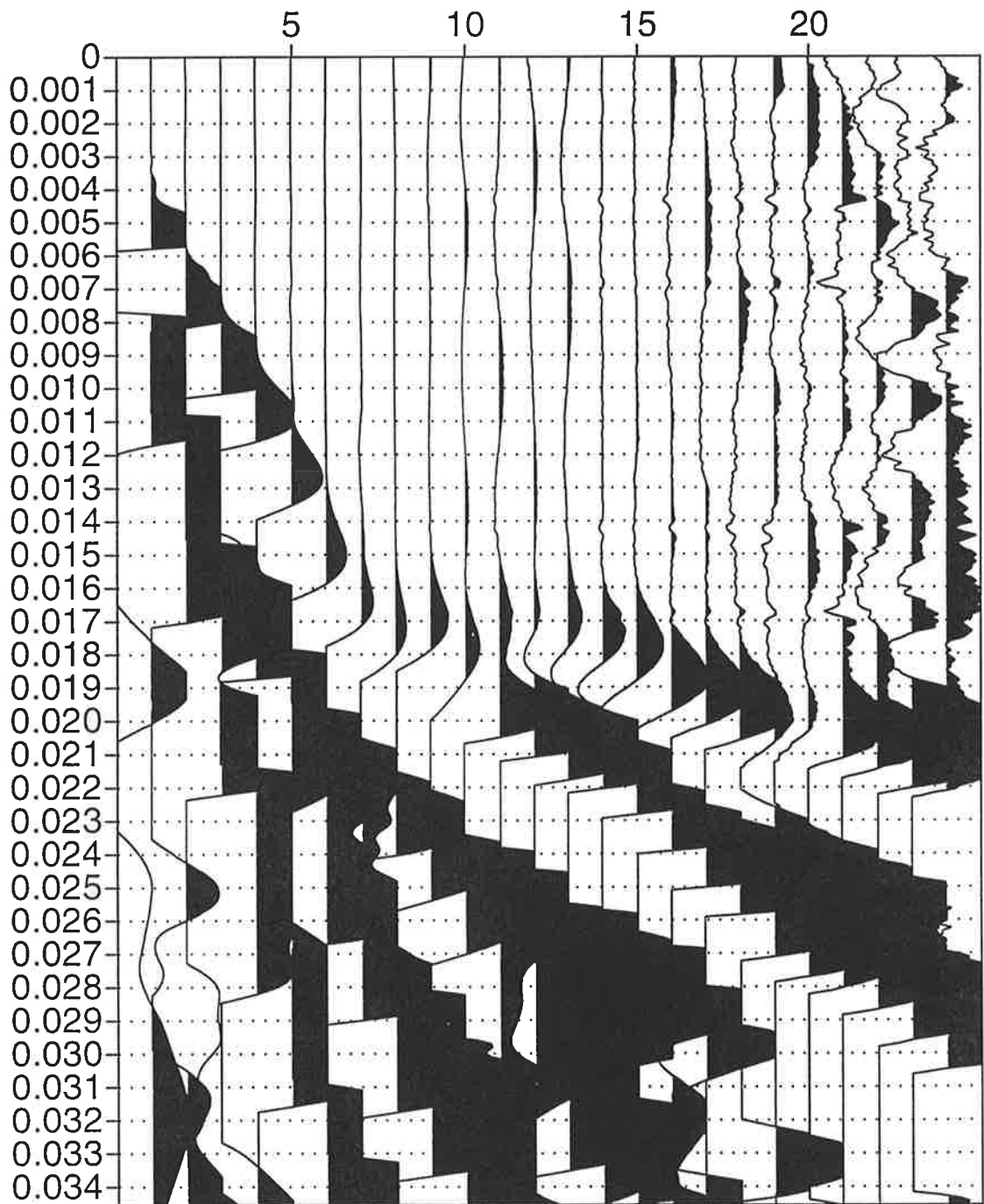
(2008.su & 2009.su) 24 metres offset shots from either end of spread. No record.

#### RESULTS

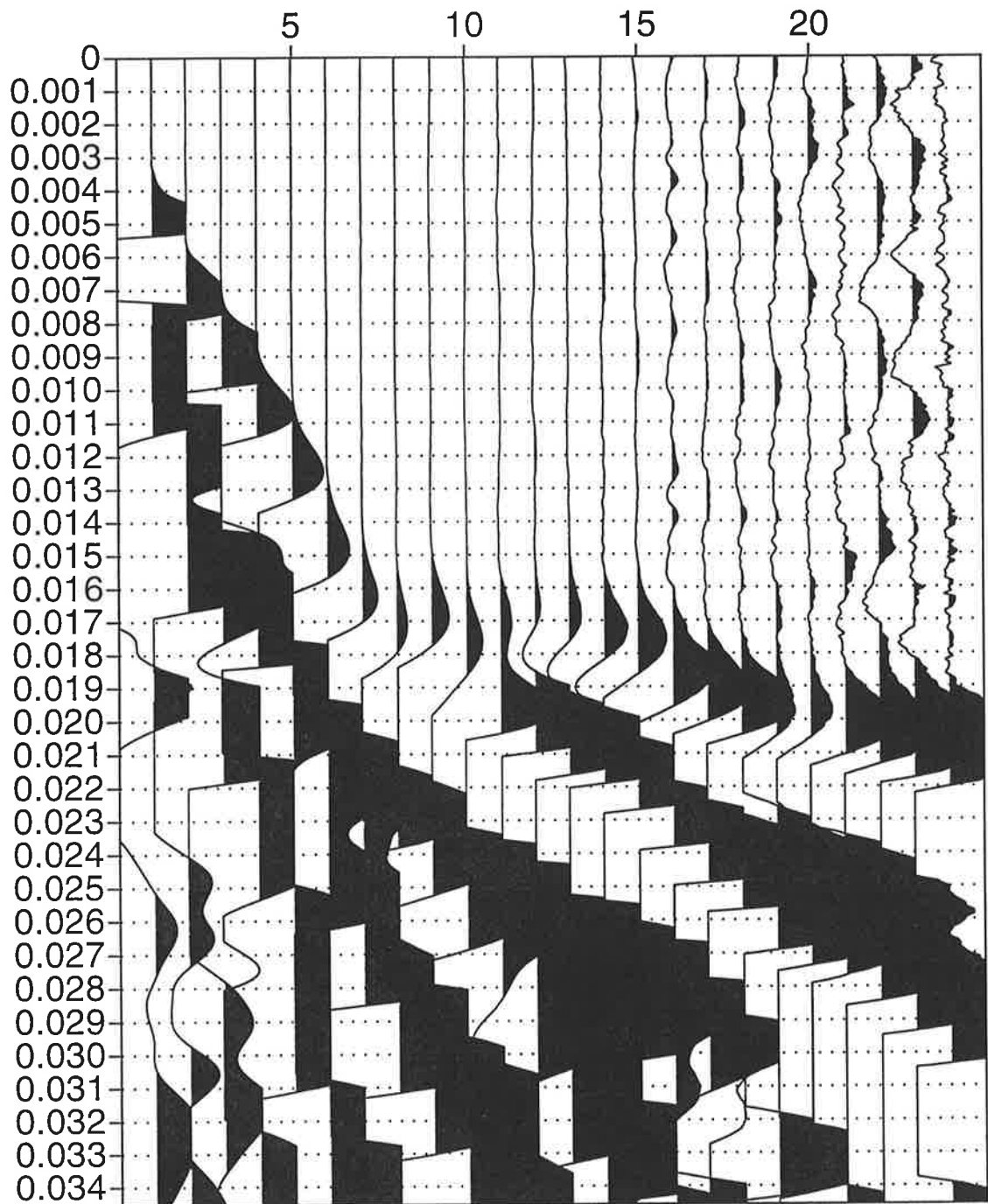
Allowance made for dip of layer in relation to surface, i.e. thins downslope in southwesterly direction. Two velocities: V1 450 ms<sup>-1</sup>, 2.5-1.6 metres alluvial gravels; V2 2280 ms<sup>-1</sup>, bedrock.



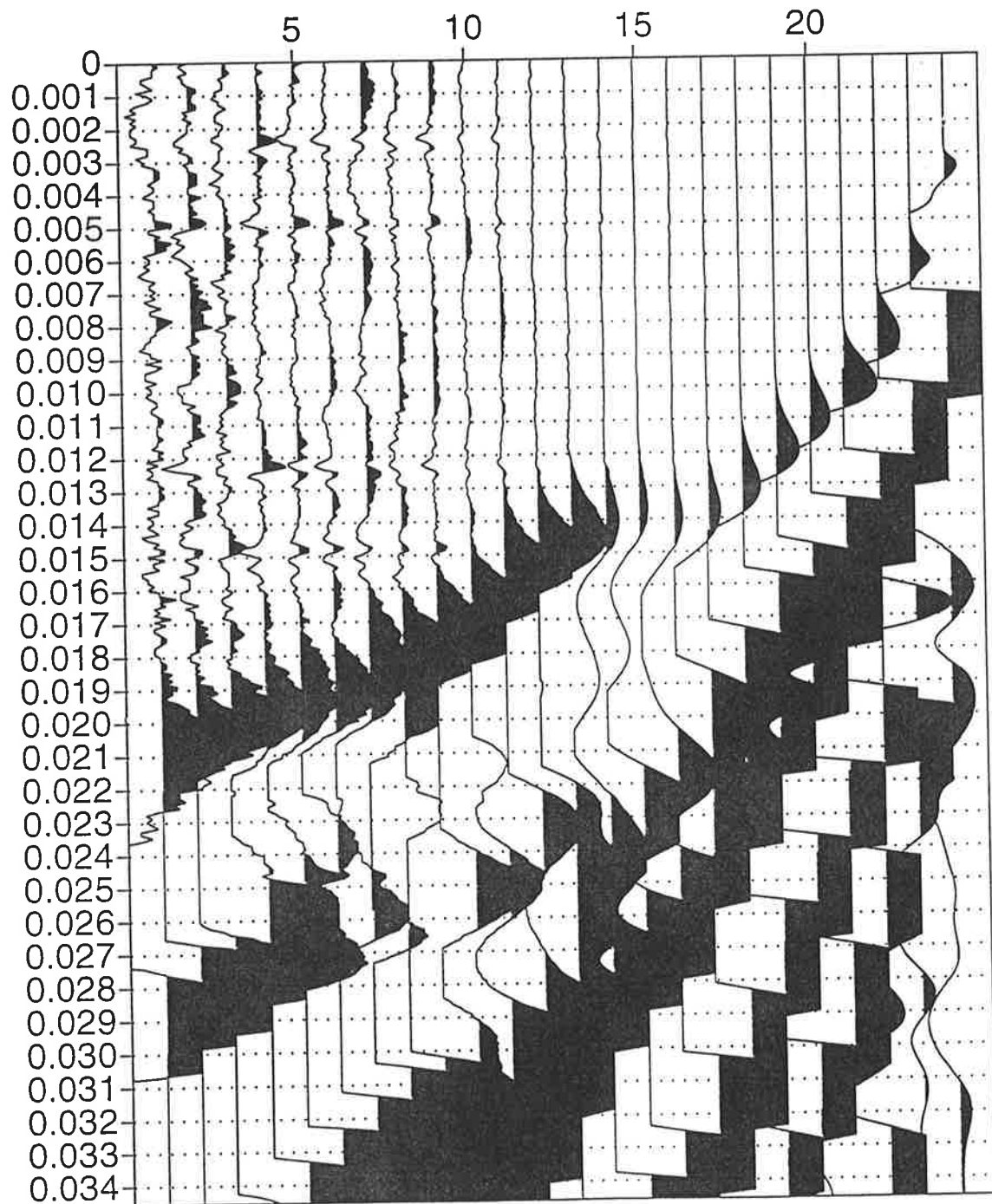
2000.su



2001.su

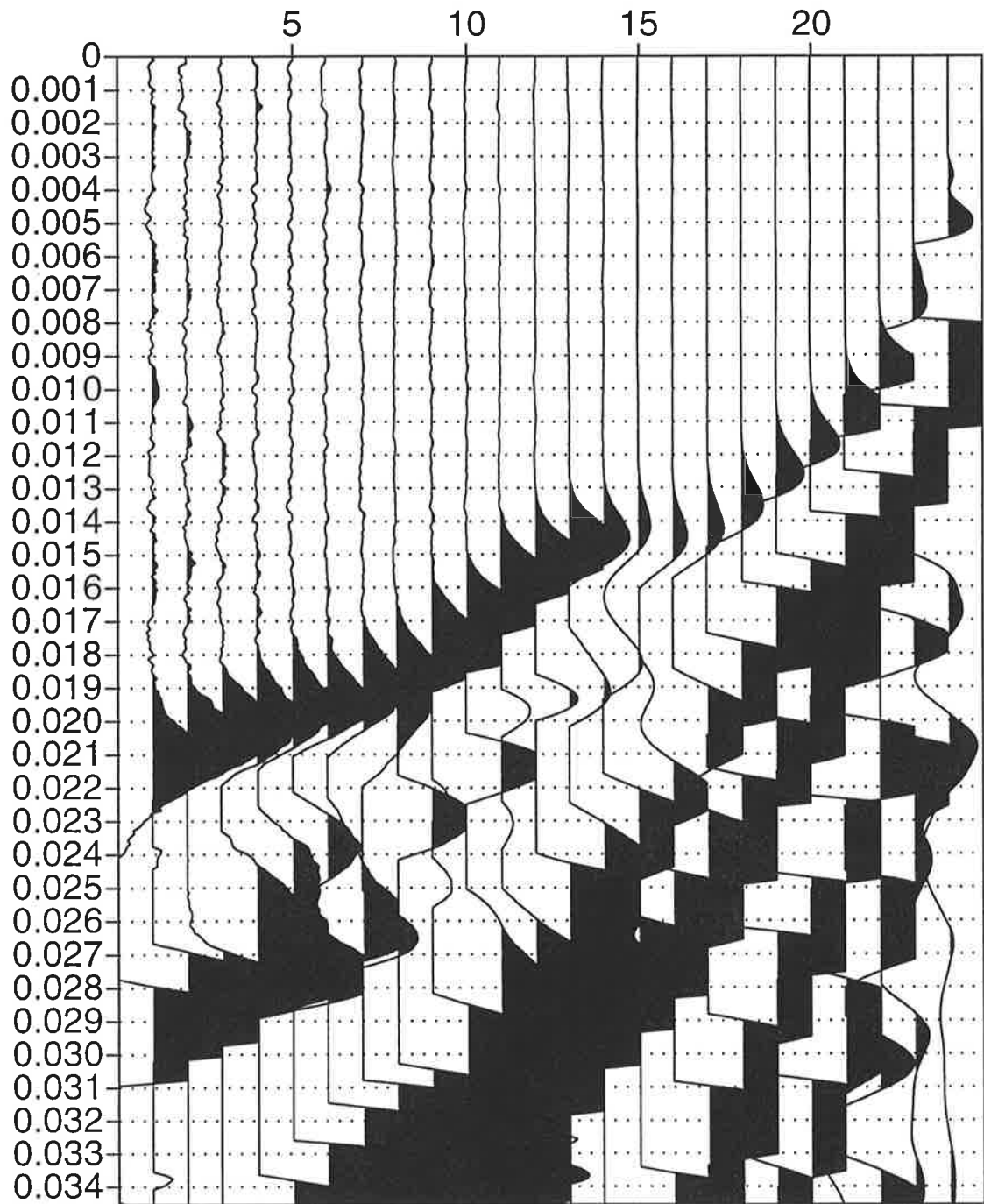


2002.su

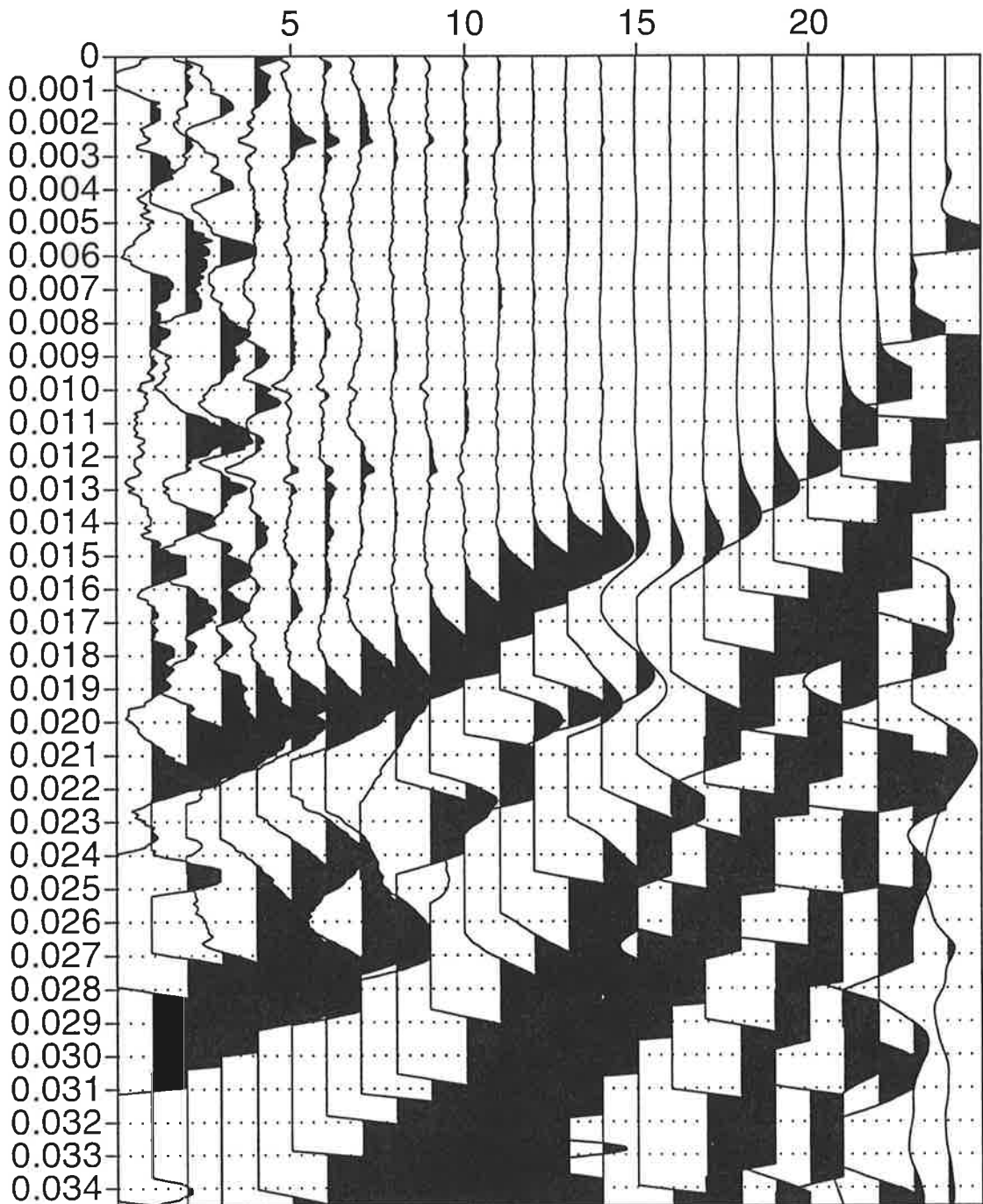


2003.su

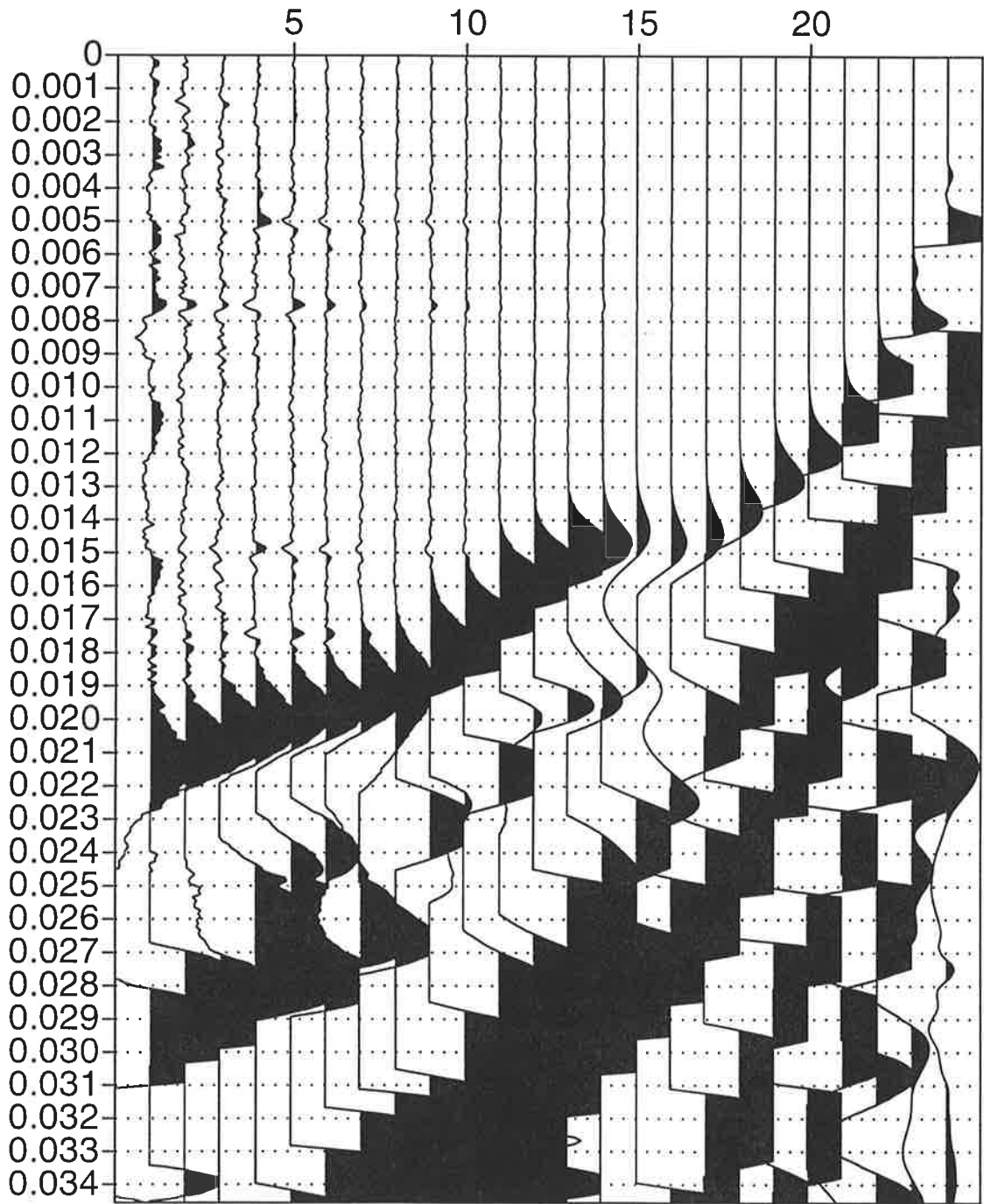




2004.su

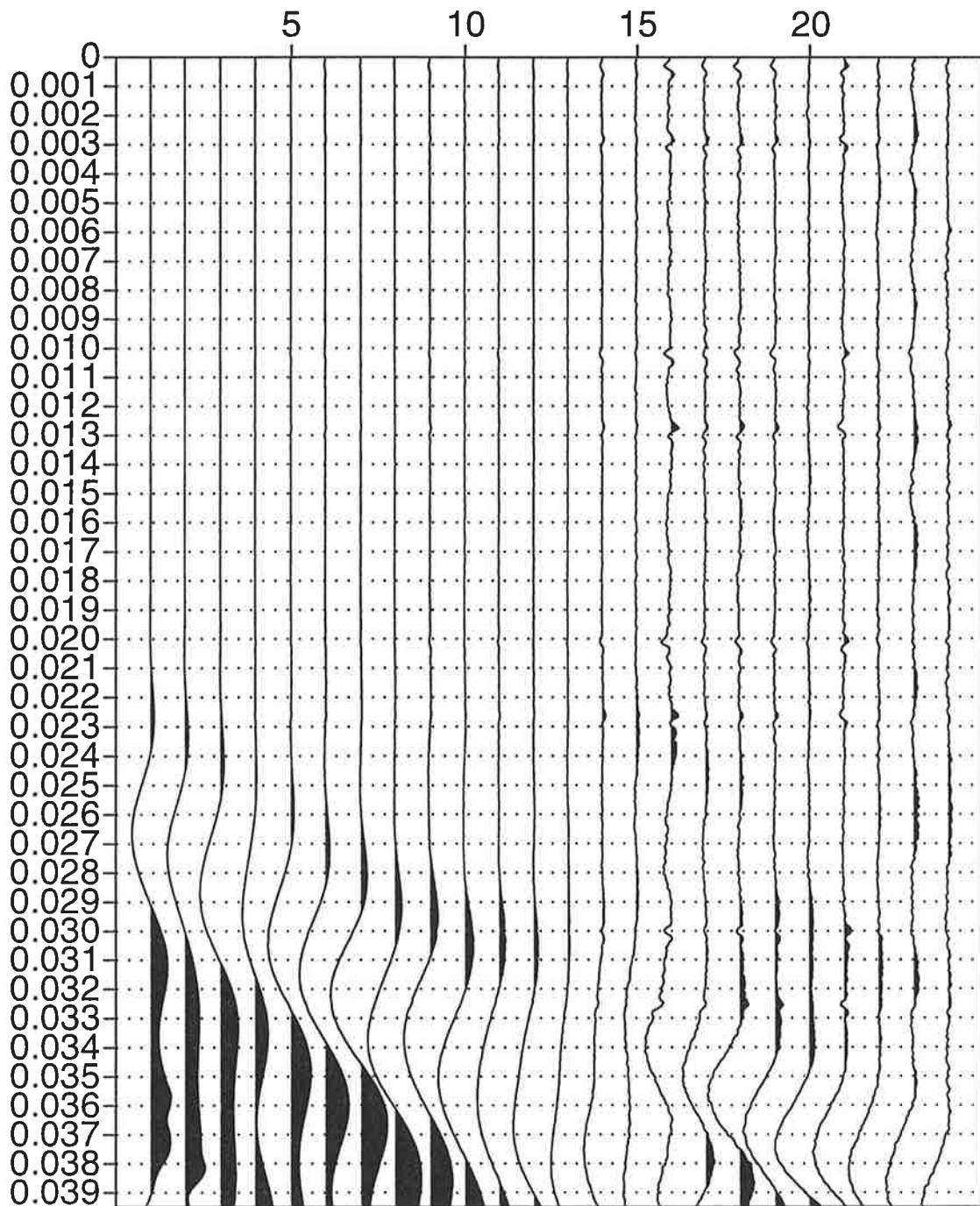


2005.su

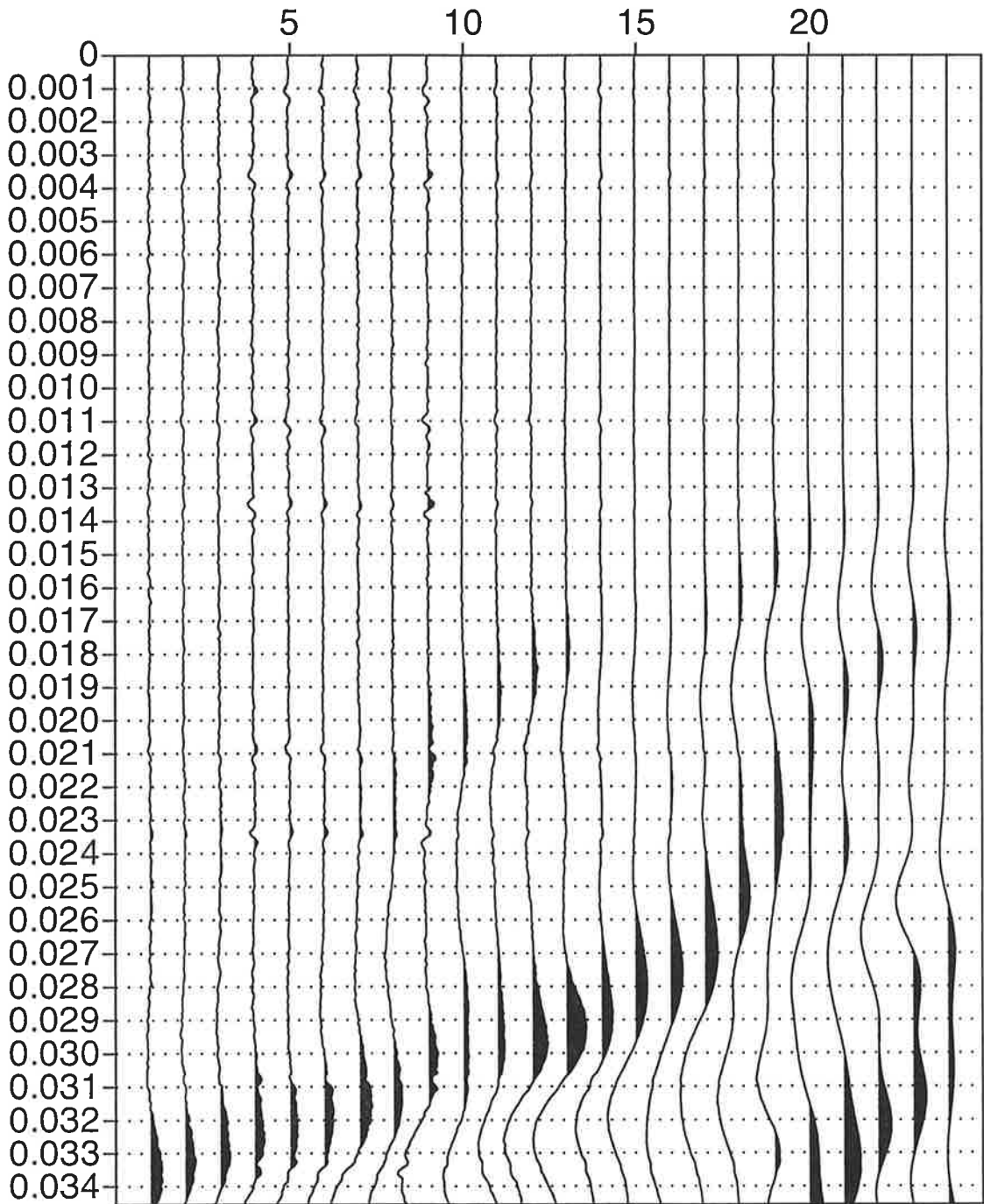


2006.su





2010.su



**2011.su**

**PEDIMENT RUN 1:** G.R. TL649337, slope  $0.5^{\circ}$ - $1^{\circ}$ , bearing  $135^{\circ}$ .

Line located on southern side of pediment, about 60 metres north of unnamed creek cut in weathered Cambrian red-brown shales beneath alluvial gravels which mask slopes and the alluvium-bedrock contact.

#### METHOD

24 geophones, 1 metre spread. Shots either end, centre, 12 metre offsets at either end. Tried 24, 36 and 48 metre offsets at NW end. No additional information received. Three metre spread (69 metres) with long (30 metres) offset test at NW end. Virtually joined by Pediment Run 4.

#### RESULTS & INTERPRETATION

Two velocities:  $V_1$   $590 \text{ ms}^{-1}$ , 1.8 metres alluvial gravels;  $V_2$   $1100 \text{ ms}^{-1}$ , 6.5 metres+(assuming  $V_3$   $3000 \text{ ms}^{-1}$ ) (?)weathered bedrock.

**PEDIMENT RUN 2:** G.R. TL645342, slope  $0^{\circ}$ - $0.5^{\circ}$ , bearing  $135^{\circ}$ .

Line located on northern side of pediment, about 100 metres south of Hayward Creek, where Cambrian red-brown arkosic sandstone outcrops in channel beneath alluvial gravels.

#### METHOD

24 geophones, 1 and 3 metre spreads. Shots either end, centre and offsets at 15 and 30 metres.

#### RESULTS & INTERPRETATION

Three velocities:  $V_1$   $400 \text{ ms}^{-1}$ , 1.7 metres alluvial gravels;  $V_2$   $1000 \text{ ms}^{-1}$ , 12.6 metres (?)weathered bedrock;  $V_3$   $2300 \text{ ms}^{-1}$ , bedrock.

**PEDIMENT RUN 3:** G.R. TL647338, slope 1°, bearing 135°.

Line located midway between and in line with Pediment Runs 2 and 3, centre of pediment remnant surface. Alluvial gravels but no outcrop.

#### METHOD

As for Pediment Run 2

#### RESULTS & INTERPRETATION

Three velocities: V1 400 ms<sup>-1</sup>, 1.6 metres alluvial gravels; V2 1350 ms<sup>-1</sup>, 6.3 metres (?)weathered bedrock; V3 3000 ms<sup>-1</sup>, bedrock

**PEDIMENT RUN 4:** G.R. TL648338, slope 0°, bearing 135°.

Line from SE end of Pediment Run 3 to NW end of Pediment Run 1.

#### METHOD

As for Pediment Run 2. Extra offset shots within 100 metres at NW end, checked by reverse offset at SE end.

#### RESULTS & INTERPRETATION

Two velocities: V1 440 ms<sup>-1</sup>, 1.3 metres alluvial gravels; V2 1300 ms<sup>-1</sup>, (?)weathered bedrock.



**PEDIMENT RUN 5:** G.R. TL647338, slope 3°, bearing 225°.

Line normal to line of Pediment Run 3 and lengthways at pediment centre.

#### METHOD

As for Pediment Run 2, but only 15 metre offset shots taken.

#### RESULTS & INTERPRETATION

Three velocities: V1 390 ms<sup>-1</sup>, 1.3 metres alluvial gravels; V2 1400 ms<sup>-1</sup>, 10 metres (?) weathered bedrock; V3 3000 ms<sup>-1</sup>, bedrock.

**APPENDIX IV**

**RAINFALL EVENTS IN THE FLINDERS RANGES REGION**

## APPENDIX IV

### RAINFALL EVENTS IN THE FLINDERS RANGES REGION

#### A. GENERAL STATEMENT

The Flinders Ranges occurs in the arid to semi-arid interior of South Australia, yet the assemblage of landforms in the western piedmont zone is clearly related to stream activity, past and present. Reports from other arid regions (e.g. Shreve, 1934; Thornthwaite, 1937; Sharon, 1972; Osborn & Laursen, 1973) indicate that severe rainstorms are most effective in flushing loose debris from the catchment into the piedmont zone where alluvial fans are deposited (Beaty, 1963; Rachocki & Church, 1990). If, on the other hand, sediment supply is limited, and the detritus coarse, streams in flood erode pediments in bedrock (Johnson, 1932b; Osborn & du Toit, 1991; Twidale, 1983a, 1987) or fanheads are entrenched (Denny, 1967; Bull, 1964b; Beaty, 1974). Parameters for precipitation, together with any stream gauging figures, are pertinent to this study of pediments and alluvial fans.

#### B. RAINFALL RECORDS FOR THE FLINDERS RANGES REGION

The rain-gauge network in the Flinders Ranges region, as in other parts of Australia, records point rainfall events only, and there are no rainfall intensity values, because gauges are checked only daily. Records have been kept for less than forty years at three synoptic weather stations, viz. Port Augusta at the head of Spencer Gulf, Hawker and Arkaroola within the upland (Figure AIV.1). However, many pastoral stations and smaller communities have undertaken weather recording from time to time, so that other records for varying periods are available throughout the area.

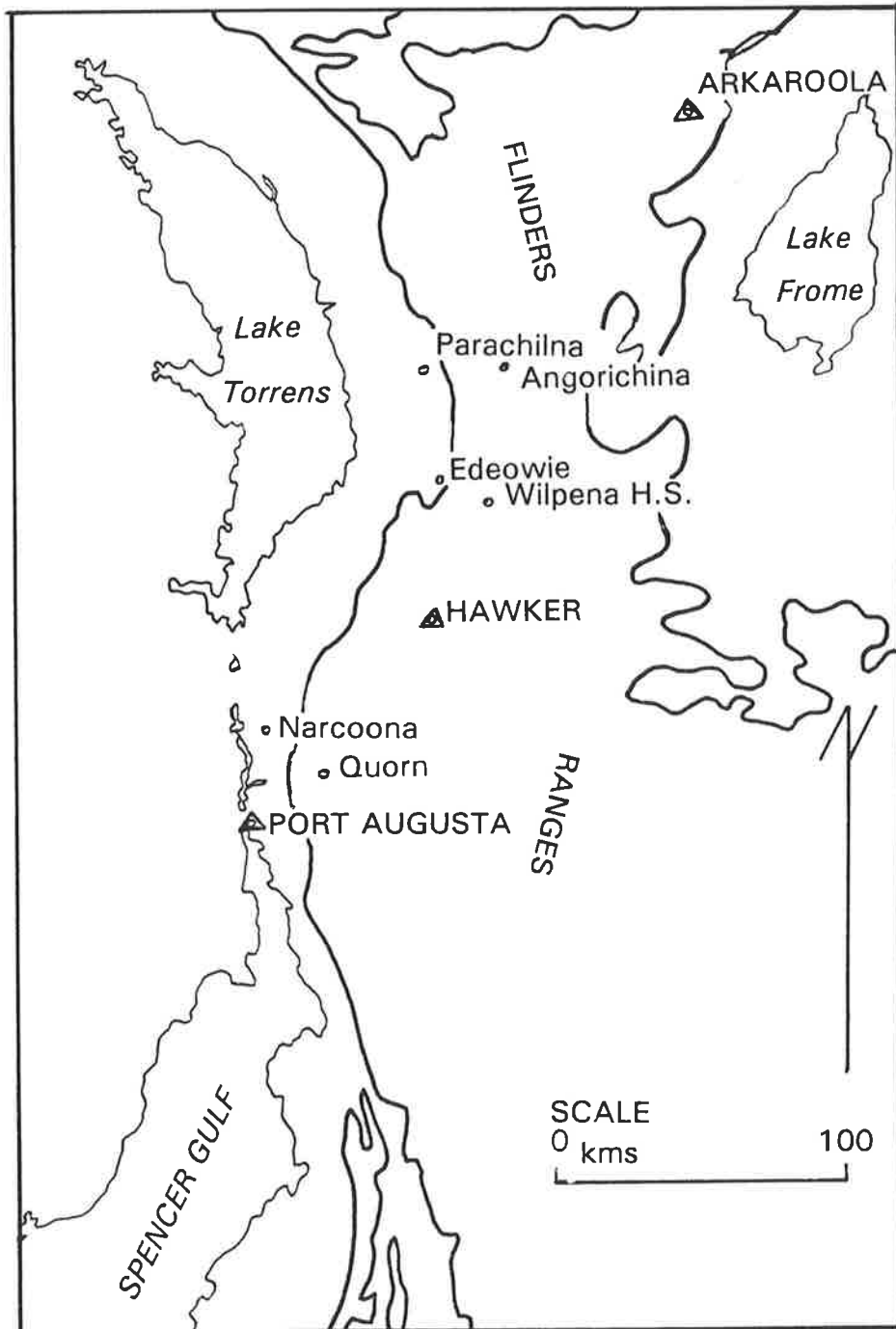


Figure AIV.1 Location of synoptic weather stations and selected rain gauge stations in the Flinders Ranges region.

## APPENDIX IV

Mean annual rainfall for the Flinders Ranges is 250mm to 350mm and for the Torrens Plain, 150mm to 250mm (Laut *et al.*, 1977). In particular, readings for Port Augusta average 238mm, Hawker 352mm and Arkaroola 238mm. An attempt was made to establish the occurrence and frequency of storms in the Flinders Ranges region using the limited data available from the synoptic stations for 1978-1992 (Table AIV.1). It was assumed that days when rainfall exceeds 50mm indicates storms rather than light, steady rain (Bureau of Meteorology, J. Dickens, pers. comm., 1994). On this basis ten storms were identified over a fourteen year period, and none of them affected the whole region. They were significant events, because in one day about one fifth, or more, of the mean annual rainfall was recorded. Most of the rainfall events listed occurred during the summer months, when thunderstorm activity is known to occur.

Consideration of available rainfall data from selected rain gauge stations within and adjacent to the study area suggest that similar extreme rainfall events have occurred. Three pairs of rain gauge stations were chosen. Each pair includes one from the upland and the other from the piedmont zone, and both stations occur on approximately the same latitude (Figure AIV.1; Table AIV.2). Their records indicate that there are months and even years when little or no precipitation is received. In some years rain falls mostly during the winter and severe storms occur occasionally.

### C. STREAM DISCHARGE RECORDS

The South Australian Engineering & Water Supply Department programme for measuring stream discharge in the Flinders Ranges does not include any of the streams of the study area. A stream gauge on the Kanyaka Creek at Old Kanyaka south of Hawker, however, confirms that maximum discharge corresponds to most of the significant rainfall events recorded at Hawker (see Table AIV.3).

Table AIV.1 Occurrence and frequency of storms in the Flinders Ranges region.

HIGHEST DAILY RAINFALL (>50 mm/day) FOR SYNOPTIC STATIONS

DATE	PORT AUGUSTA 32°32'S 137°47'E		HAWKER 31°53'S 138°25'E		ARKAROO LA 30°19'S 139°20'E	
	RAINFALL	DAY*	RAINFALL	DAY*	RAINFALL	DAY*
07-09-78	5.6		<15.0	22	#54.0	
17-01-79	<15.4	20	8.0		#50.2	
21-02-79	<26.4	23	<28.0	23	#113.0	
28-09-79	<30.6	27	<21.6	27	#56.0	
22-04-80	<14.2	23	#60.8		<36.4	23
28-01-81	17.6		#59.0		<13.4	29
14-01-84	<9.0	26	<4.0	26	#182.0	
14-03-89	#50.4		#173.0		-	
01-03-92	#90.8		18.8		8.0	
06-10-92	<16.6	8	#53.8		<5.8	

# denotes daily rainfall in excess of 50 mm: probable thunderstorm  
 DAY\* recorded daily maximum for the month (for a different day)

Source: NATIONAL CLIMATE CENTRE. BUREAU OF METEOROLOGY

Table AIV.2 Rain gauge stations within and adjacent to the study area.

HIGHEST DAILY RAINFALL EACH MONTH OF YEAR FOR SELECTED STATIONS

TORRENS PLAIN		FLINDERS RA.		TORRENS PLAIN		FLINDERS RA.	
<b>PARACHILNA P O</b>		<b>ANGORICHINA</b>		<b>EDEOWIE</b>		<b>WILPENA STN.</b>	
(1930-1980)		(1866-1977)		(1884-1966)		(1903-1985)	
Lat.31°08'S		Lat.31°08'S		Lat.31°27'S		Lat.31°31'S	
Long.138°24'E		Long.138°34'E		Long.138°27'E		Long.138°37'E	

MO	DAY	YEAR	R/F	DAY	YEAR	R/F	MO	DAY	YEAR	R/F	DAY	YEAR	R/F
J	3	1941	693	4	1968	572	J	19	1937	813	17	1946	848
F	2	1950	1143	2	1950	1275	F	2	1950	762	25	1939	1143
M	17	1950	841	17	1950	739	M	6	1910	594	17	1950	1011
A	19	1968	335	13	1976	558	A	7	1921	457	29	1954	457
M	14	1974	582	9	1974	490	M	2	1889	533	29	1921	940
J	20	1957	483	20	1957	493	J	19	1957	668	29	1939	1372
J	11	1969	267	16	1973	292	J	18	1917	234	12	1969	813
A	18	1979	238	24	1938	302	A	18	1886	305	19	1979	572
S	8	1949	279	19	1946	267	S	27	1964	442	16	1975	762
O	7	1975	356	8	1975	470	O	16	1908	335	13	1976	546
N	29	1937	516	29	1958	318	N	12	1920	940	12	1920	1257
D	12	1975	574	13	1975	1065	D	23	1914	808	23	1914	1118

TORRENS PLAIN		FLINDERS RA.	
<b>NARCOONA</b>		<b>QUORN</b>	
(1940-1974)		(1883-1972)	
Lat.32°13'S		Lat.32°19'S	
Long.137°14'E		Long.138°15'E	

MO	DAY	YEAR	R/F	DAY	YEAR	R/F
J	31	1974	530	19	1937	665
F	18	1946	737	18	1946	983
M	2	1941	338	1	1921	1321
A	14	1954	414	17	1971	432
M	10	1956	396	12	1884	549
J	8	1971	292	13	1898	533
J	24	1949	206	5	1968	376
A	27	1973	292	30	1910	462
S	7	1960	284	19	1915	318
O	14	1956	330	23	1938	460
N	11	1970	173	12	1920	511
D	1	1966	518	16	1923	480

Source: NATIONAL CLIMATE CENTRE. BUREAU OF METEOROLOGY.

Table AIV.3 Stream gauge records for Kanyaka Creek compared with rainfall records at Hawker.

**STREAM GAUGE RECORDS**

**509503 KANYAKA CREEK** at Old Kanyaka Lat.32°05' Long.138°17' (1977-1990)  
Catchment: 180 km<sup>2</sup>

YEAR	ANNUAL MEAN	ANNUAL TOTAL	DAILY MAX	DAILY MIN	REMARKS	DRY MONTHS
1977					Record began Sept 19, late Nov max 2850	
1978	0.43	156.90	28.22	0.00	early Jul 66.4/156.9+max;	mid Jan-late Mar
1979	1.91	696.10	577.70	0.00	late Dec 581.8/696.1+max;	Jan-late Feb
1980	0.25	92.54	3.40	0.00		mid Jan-mid Apr,mid Nov-Dec
1981	0.35	127.70	36.76	0.00	late Jan max;	Feb-mid May,Nov-Dec
1982	0.16	58.26	0.63	0.00		Jan-late May,Nov-Dec
1983	4.04	1472.00	700.60	0.00	early Apr 733.7/1472+max;	Jan-Mar
1984	0.27	98.95	21.57	0.00		mid Jan-mid May,mid Nov-Dec
1985	0.28	102.40	28.38	0.00		Jan-late May
1986	0.29	106.70	13.12	0.00		Jan-Apr,Dec
1987	0.62	227.50	107.50	0.00	28 Feb max;	Jan-27 Feb,Nov-Dec
1988	0.21	75.71	8.90	0.00		Jan-Apr,Oct-Dec
1989	12.57	4589.00	3898.00	0.00	mid Mar 4171/4589+max;	Jan-Feb,late Dec
1990					Record ceased 27 Aug	Jan-29 Apr;

Stream discharge volume in megalitres.

Source: Engineering & Water Supply Department, South Australia

**MAXIMUM STREAM DISCHARGES COMPARED WITH RAINFALL RECORD**

**509503 KANYAKA CREEK**                      **HAWKER P O** Lat.31°53'S Long.138°25'E (1966-1992)  
**MAX.STREAM DISCHARGE**                      **RAINFALL RECORDS**

DAY/MONTH	YEAR	MONTH	MONTHLY TOTAL mm	HIGHEST DAILY mm	DATE
late November	1977	November	103.6	85.8	28 November
early July	1978	June	95.2	29.0	27 June
*min. discharge	1980	April	106.6	60.8	22 April
late January	1981	January	85.4	59.0	28 January
early April	1983	April	61.8	38.8	4 April
28 February	1987	February	44.8	42.0	28 February
mid March	1989	March	236.0	173.0	14 March

N.B. No other rainfall events when  
>44.8mm fell on one day recorded at  
Hawker

Source: NATIONAL CLIMATE CENTRE.      BUREAU OF METEOROLOGY.



## D. DISCUSSION

A two to three day cycle of easterly moving high and low pressure systems is typical of the weather patterns affecting southern Australia. During the winter months and associated with the eastward moving low-pressure systems, strong cold front activity resulting in thunderstorms extends northwards into the study area from the southern settled districts of South Australia. During the summer months warm to hot conditions prevail when high pressure systems situated south of the Great Australian Bight direct a southeasterly air flow over the state. Little or no rain falls as a result of frontal activity. However, severe thunderstorms lasting from a few minutes to several days occur during the summer and autumn months in the Flinders Ranges, when moist tropical air streams into South Australia from the north and 'hooks up' with cold fronts associated with the prevailing westerlies. They may be isolated convective cells, or numerous convective cells embedded in larger storm systems. The thunderstorms are of convective origin, but their development is enhanced by the orographic effect of the precipitous western scarp of the Flinders Ranges (Bureau of Meteorology, 1991).

The smallest thunderstorms for the Flinders Ranges are likely to be only 5-10 kilometres across (J.Dickens, Bureau of Meteorology, pers comm., 1994) and therefore may go undetected by the rain-gauge network. The few severe short-duration rainstorms that have been well-documented in Australia indicate that the rainfall potential here is similar to that of the United States of America, which has a much larger data base. Using 'adjusted United States data' estimations are made for PMP, i.e. probable maximum precipitation, for areas of 1000 square kilometres and durations of three hours in inland and southern Australia. Design Rainfall Isopleth mapping indicates that in the study area thunderstorms with an intensity of 18mm per hour will occur once every two years and those with an intensity of 50mm per hour will occur only once in fifty years (Institution of Engineers, 1987).

#### APPENDIX IV

Most of the catchments of the Wyacca-Emeroo region are of similar dimensions to the typical size and shape of storm cells for the study area. Therefore, it is impossible for one storm cell to be restricted to one catchment and have only local effects. Further north, however, streams like the Parachilna, Brachina and Bunyeroo, drain areas of more than 250 square kilometres and thunderstorm activity could be entirely contained within their boundaries and cause unique morphological effects.

**APPENDIX V**

**BOULDER MEASUREMENTS: MAJOR ALLUVIAL FANS, WYACCA-EMEROO  
REGION**

## **APPENDIX V**

### **BOULDER MEASUREMENTS: MAJOR ALLUVIAL FANS, WYACCA-EMEROO REGION**

Field work 23-28 February & 24 July 1992

#### **METHOD:**

Series of boulder measurements taken in the Wyacca-Emeroo piedmont using station tracks to make several radial crossings.

Every 300 metres and 10 metres from the track, the largest rock lying on the surface within a 3 metre square was measured.

Three axial measurements, rock type, degree of roundness and setting were recorded.

See also Figure 4.17 (a) Boulder measurement ('b' axis) graphed against distance from fanhead (kms), and (b) location map of boulder measurement sites.

APPENDIX V

BO-1 WILKATANA NORTH: E-W RADIUS

SITE	BOULDER AXES			SHAPE	ROCK TYPESETTING		FAN SLOPE
	A	B	C				
1	110	80	70	sub-angular	sandstone	general scatter	
1	1250	500	320	sub-rounded	quartzite	bar and terrace	
2	120	110	60	sub-rounded	sandstone	gilgai	
3*	190	170	90	sub-angular	sandstone	gilgai	
4	600	240	220	sub-rounded	quartzite	scatter + one bo.	
5	190	170	140	sub-angular	sandstone	gilgai	
6	510	220	140	sub-angular	sandstone	gilgai	
7	220	180	120	sub-angular	sandstone	gilgai	
8	210	160	100	sub-angular	sandstone	gilgai	
9	220	180	90	angular	sandstone	gilgai	
10	160	90	70	sub-angular	sandstone	gilgai	
10	440	430	240	rounded	quartzite	> soil, < rock	
11	200	90	80	angular	sandstone	gilgai: pebbles	
12	440	430	240	sub-rounded	quartzite	gilgai: cobbles	
13	65	60	55	sub-rounded	quartzite	gilgai	
14	370	230	190	rounded	quartzite	gilgai, no topsoil	
15	140	90	80	rounded	sandstone	mostly soil	
16	120	80	60	sub-angular	sandstone	thin scatter	
17	90	80	80	rounded	quartzite	thin scatter	
18	120	70	70	rounded	sandstone	thin scatter	
19	160	140	120	sub-rounded	sandstone	patch, gullies/dam	
20	-	-	-	-	-	no rock	

\* Soil sample 965-61 (see Appendix VI: XRD results and sediment analysis)

APPENDIX V

BO-2 DEPOT CREEK: E-W RADIUS

SITE	BOULDER AXES			SHAPE	ROCK TYPESETTING		FAN SLOPE
	A	B	C				
1	180	120	90	angular	sandstone	scatter	1.5°
2	180	140	80	angular	sandstone	gilgai	
3	120	80	60	sub-angular	sandstone	gilgai	2°
4	130	120	100	sub-angular	quartzite	gilgai	
5	360	270	220	sub-rounded	sandstone	gilgai	
6	290	120	100	sub-angular	quartzite	gilgai	
7*	300	230	200	sub-rounded	limestone	gilgai	
8	240	180	170	sub-angular	quartzite	gilgai	
9	200	110	100	sub-rounded	sandstone	gilgai	
10	140	100	80	sub-angular	quartzite	gilgai	
11	220	130	110	sub-angular	quartzite	gilgai	1°
12	330	250	230	sub-rounded	limestone	gilgai	
13	180	160	100	sub-rounded	sandstone	gilgai	
14	120	120	60	sub-angular	sandstone	gilgai	
15	160	110	100	rounded	limestone	gilgai	
16	130	90	70	sub-rounded	quartzite	gilgai	
17	100	80	70	sub-rounded	sandstone	gilgai	
18	90	80	65	sub-rounded	quartzite	gilgai	
19	-	-	-	-	-	no rock	<1°
20	?	?	?	-	-	rock fill at gate	

\* Soil sample 965-59 (see Appendix VI: XRD results and sediment analysis)

APPENDIX V

BO-3 DRY SOUTH CREEK: ESE-WNW RADIUS

SITE	BOULDER AXES			SHAPE	ROCK TYPESETTING		FAN SLOPE
	A	B	C				
1	460	330	280	sub-rounded	sandstone	bar and terrace	2°
2	460	350	240	sub-angular	sandstone	bar and terrace	
3	150	100	70	sub-angular	siltstone	scatter, low bars	
4*	210	120	110	sub-angular	siltstone	scatter, low bars	
5	110	80	80	sub-rounded	quartzite	scatter, low bars	
6	130	110	100	sub-rounded	sandstone	bar and terrace	
7	140	110	100	sub-rounded	sandstone	gilgai	
8	90	60	60	sub-angular	sandstone	gilgai	
9	100	70	50	sub-angular	sandstone	scatter	
10**	80	70	60	rounded	siltstone	gilgai	
11	70	60	50	sub-rounded	sandstone	gilgai	
12	160	110	100	sub-rounded	sandstone	gilgai	
13	130	90	80	sub-rounded	sandstone	scatter	
14	170	90	90	sub-angular	sandstone	gilgai	
15	290	160	140	sub-angular	sandstone	gilgai	

\* Soil sample 965-56 (see Appendix VI: XRD results and sediment analysis)

\*\* Soil sample 965-55 (see Appendix VI: XRD results and sediment analysis)

APPENDIX V

BO-4 SOUTH CREEK: ENE-WSW RADIUS

SITE	BOULDER AXES			SHAPE	ROCK TYPESETTING		FAN SLOPE
	A	B	C				
1	130	90	70	sub-rounded	quartzite	general cover	2°
2	450	350	300	rounded	quartzite	bar and terrace	
3	250	190	180	sub-rounded	sandstone	scatter	
4	170	130	130	sub-rounded	sandstone	scatter	
5	290	210	130	sub-rounded	quartzite	scatter	
6	180	100	70	sub-rounded	sandstone	gilgai	
7	170	140	100	sub-rounded	quartzite	gilgai	
8*	400	350	320	rounded	sandstone	gilgai	
9	340	320	220	sub-rounded	quartzite	gilgai	
10	400	350	230	sub-rounded	limestone	bar and terrace	
11	70	50	25	sub-rounded	sandstone	scatter	
12	400	340	230	sub-rounded	sandstone	bar and terrace	
13	460	290	230	sub-rounded	sandstone	bar and terrace	
14**	60	50	50	sub-rounded	sandstone	general cover	
15	330	220	200	sub-rounded	sandstone	scatter	
16	90	75	45	sub-rounded	sandstone	bar and terrace	
17	100	70	40	sub-angular	sandstone	bar and terrace	
18	100	70	50	sub-angular	sandstone	very few	0.5°

\* Soil sample 965-53 (see Appendix VI: XRD results and sediment analysis)

\*\* Soil sample 965-54 (see Appendix VI: XRD results and sediment analysis)



APPENDIX V

BO-5 DEEP CREEK: SE-NW RADIUS

SITE	BOULDER AXES			SHAPE	ROCK TYPESETTING		FAN SLOPE
	A	B	C				
1	170	150	80	angular	sandstone	gilgai	2°
2	220	130	80	angular	sandstone	gilgai	
3*	140	70	60	sub-angular	quartzite	gilgai	
4	130	70	50	sub-angular	quartzite	gilgai	
5	180	130	80	sub-angular	sandstone	gilgai	
6	160	100	90	sub-angular	sandstone	gilgai	
7	180	100	90	sub-angular	sandstone	gilgai	
8	160	150	110	sub-angular	sandstone	gilgai	
9	190	120	80	sub-angular	sandstone	gilgai	
10	120	80	60	sub-angular	sandstone	general cover	
11	180	100	70	sub-angular	sandstone	gilgai	1°
12	180	160	110	sub-rounded	sandstone	general cover	
13	-	-	-	-	-	very few	< 1°

\* Soil sample 965-51 (see Appendix VI: XRD results and sediment analysis)

APPENDIX V

BO-6 DEEP CREEK: NE-SW RADIUS

SITE	BOULDER AXES			SHAPE	ROCK TYPESETTING		FAN SLOPE
	A	B	C				
1	130	90	60	sub-rounded	sandstone	general cover	2°
2	120	90	80	sub-rounded	sandstone	general cover	
3	260	140	70	angular	sandstone	bar and terrace	
4	470	340	290	angular	quartzite	bar and terrace	
5	360	220	210	sub-rounded	sandstone	bar and terrace	
6*	250	140	70	angular	sandstone	bar and terrace	
7	180	130	100	sub-angular	sandstone	bar and terrace	
8	190	150	130	sub-angular	sandstone	bar and terrace	
9	130	90	50	sub-angular	sandstone	bar and terrace	
10	180	150	120	sub-angular	sandstone	bar and terrace	
11	90	85	40	sub-angular	sandstone	general cover	
12	260	140	140	sub-angular	quartzite	bar and terrace	
13	170	150	110	sub-angular	limestone	bar and terrace	
14	110	75	70	angular	quartzite	general cover	

\* Soil sample 965-52 (see Appendix VI: XRD results and sediment analysis )

**APPENDIX VI**

**X-RAY DIFFRACTION ANALYSIS OF SOIL SAMPLES: MAJOR ALLUVIAL  
FANS, WYACCA-EMEROO REGION**

## APPENDIX VI

### X-RAY DIFFRACTION ANALYSIS OF SOIL SAMPLES: MAJOR ALLUVIAL FANS, WYACCA-EMEROO REGION

Mr J. Stanley, Department of Geology & Geophysics, University of Adelaide, undertook the X-Ray Diffraction analyses and also demonstrated how to isolate the clay fraction from each sample.

#### METHOD

Place soil sample in labelled container 6mm deep

Add dispersion solution (2.5ml for 10g of sample)

Shake for 10 minutes in manual shaker

Pour mixture into 500ml cylinder, add distilled water to fill container and mix thoroughly

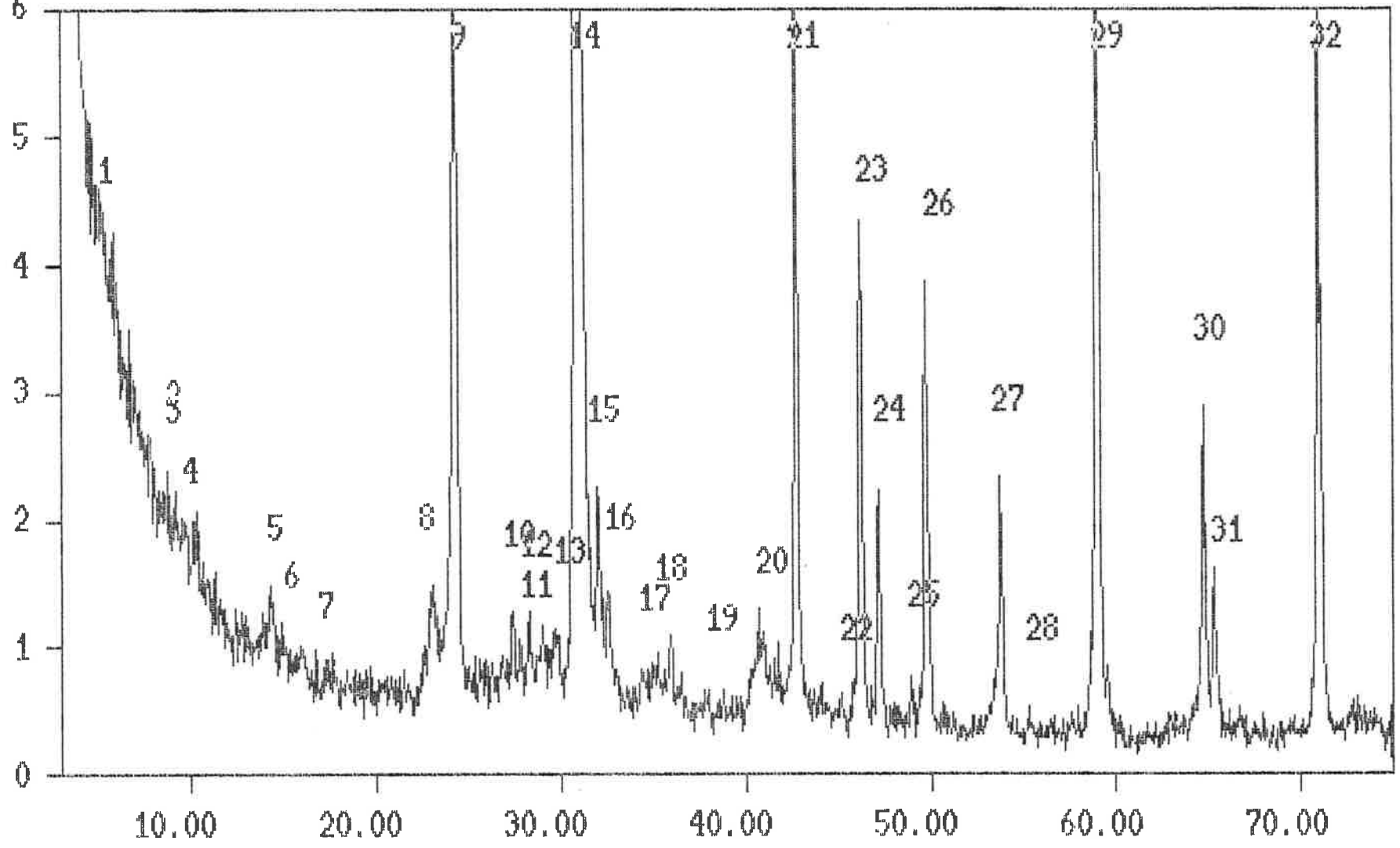
Leave to settle for 35 minutes

Pipette off the top 5cm without disturbing the mixture and return to washed (with distilled water) labelled container

Wash pipette with distilled water between samples to avoid cross contamination.

**X-RAY DIFFRACTION ANALYSIS: BULK SOIL SAMPLES, MAJOR ALLUVIAL  
FANS, WYACCA-EMEROO REGION**

10<sup>2</sup> 6 965-51



965-51

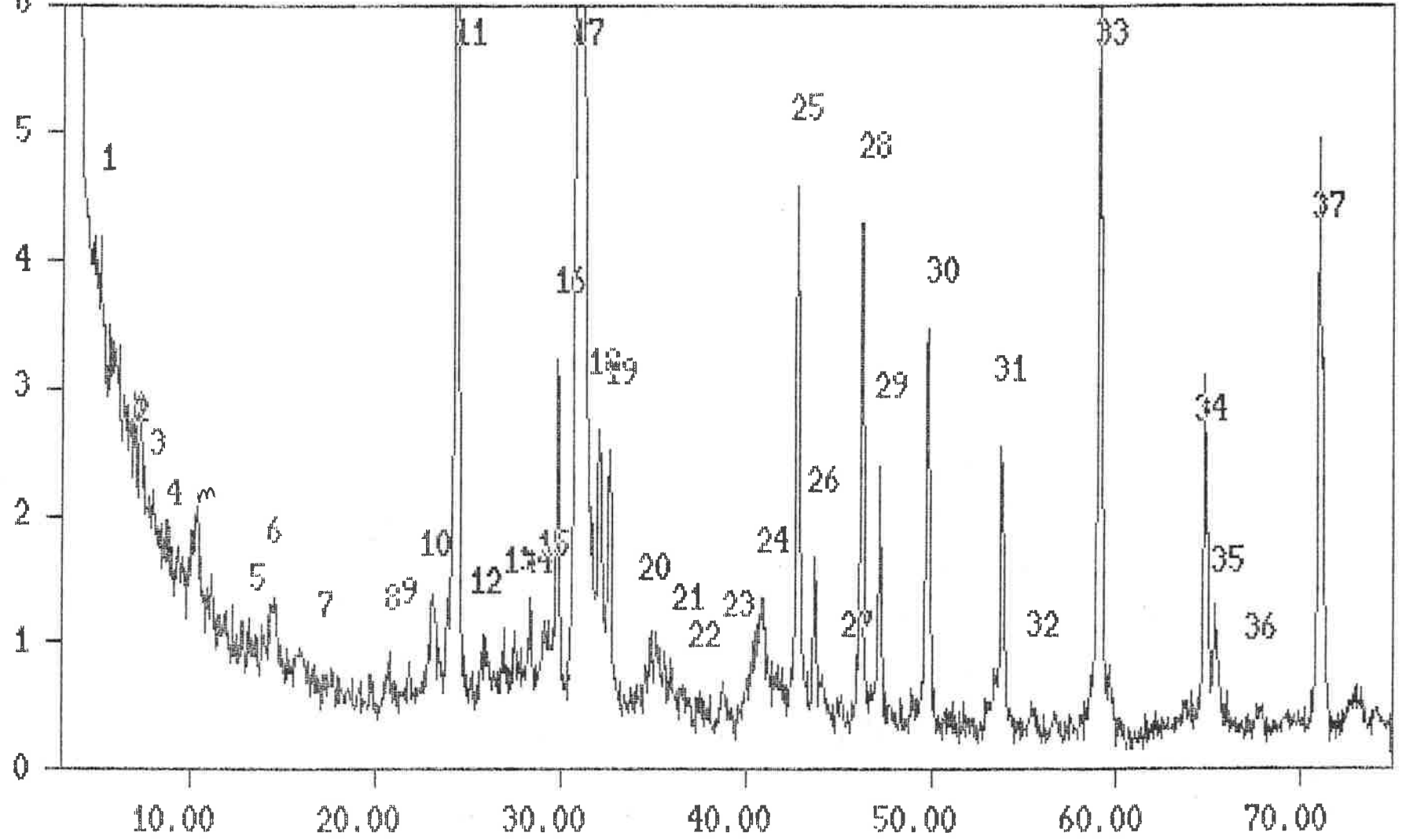
3  
75  
Co  
1.7902  
09-30-1991

SCH = 11 SENS = 2.0

M	2THETA	DSPACE	HEIGHT
1	5.850	<del>17.5411</del>	427.0
2	8.750	<del>11.7338</del>	239.0
3	9.200	<del>11.1610</del>	224.0
4	10.250	10.0203m	200.0
5	14.350	7.1665K	149.0
6	15.950	6.4516	102.0
7	17.300	<del>5.9515</del>	91.0
8	23.000	4.4897	149.0
9	24.250	4.2615φ	2217.0
10	27.400	3.7794	128.0
11	27.850	3.7195	105.0
12	28.300	3.6615	127.0
13	29.700	3.4925	114.0
14	31.050	3.3442φ	7104.0
15	32.050	3.2424φ	226.0
16	32.600	3.1892φ	144.0
17	34.400	3.0270c	82.0
18	35.900	2.9044d	108.0
19	37.900	2.7563	65.0
20	40.850	2.5649	107.0
21	42.700	2.4586φ	784.0
22	45.150	2.3316	64.0
23	46.200	2.2815φ	434.0
24	47.150	2.2380φ	224.0
25	48.950	2.1605	78.0
26	49.750	2.1279φ	388.0
27	53.750	1.9801φ	233.0
28	55.300	1.9288	53.0
29	59.000	1.8177φ	1123.0
30	64.750	1.6717φ	290.0
31	65.300	1.6591φ	163.0
32	71.000	1.5414φ	607.0

QUARTZ  
+ FELDSPAR  
+ ~~K~~ MICA (MUSCOVITE)  
+ KAOLINITE (MAYBE CATON)  
+ DOLOMITE  
+ TRACE CALCITE?

10<sup>2</sup> 6 965-52





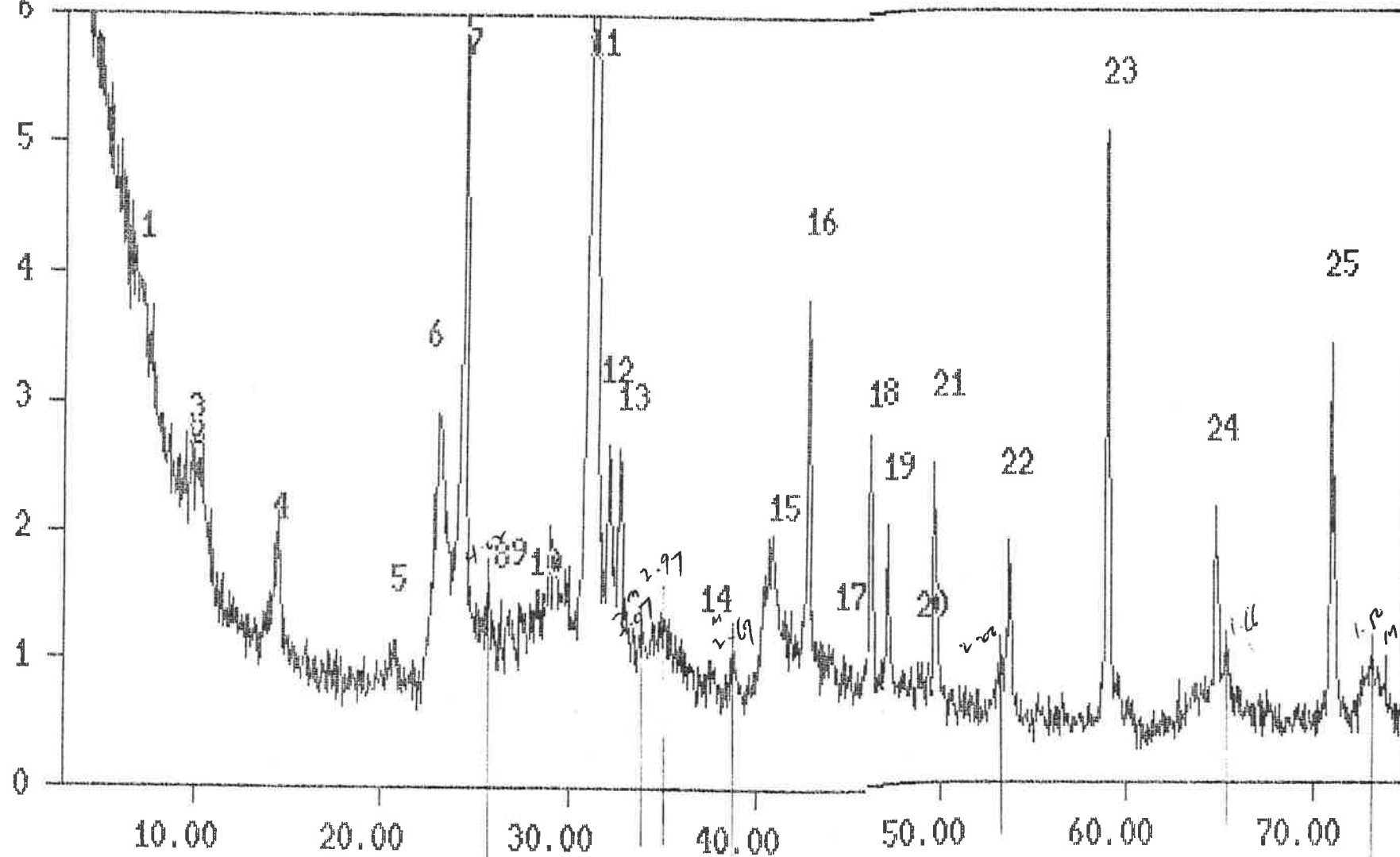
3  
75  
Co  
1.7902  
09-30-1991

SCH = 15 SENS = 1.0

M	2THETA	DSPACE	HEIGHT
1	5.050	<del>20.3176</del>	418.0
2	7.350	<del>13.9648</del>	298.0
3	8.700	<del>11.8011</del>	195.0
4	9.400	<del>10.9240</del>	173.0
5	13.350	<del>7.7006</del>	119.0
6	14.500	7.0928 K	134.0
7	17.550	5.8674	74.0
8	20.600	5.0061 m	74.0
9	21.850	4.7229	85.0
10	23.000	4.4897 m	133.0
11	24.300	4.2528 Q	1243.0
12	25.850	4.0018 F	106.0
13	27.550	3.7592	110.0
14	28.250	3.6679	113.0
15	29.150	3.5570	116.0
16	29.800	3.4811	324.0
17	31.100	3.3389 Q	7960.0
18	32.100	3.2375 F	267.0
19	32.650	3.1844 K	251.0
20	35.000	2.9767	110.0
21	36.050	2.8927	88.0
22	37.550	2.7811	62.0
23	38.800	2.6948	69.0
24	40.850	2.5649	134.0
25	42.800	2.4532 Q	459.0
26	43.700	2.4050	168.0
27	45.100	2.3341	59.0
28	46.250	2.2791 Q	430.0
29	47.200	2.2358 Q	240.0
30	49.800	2.1259 Q	347.0
31	53.800	1.9784 Q	255.0
32	55.500	1.9224	54.0
33	59.050	1.8163 Q	684.0
34	64.800	1.6705 Q	310.0
35	65.400	1.6569 Q	129.0
36	67.700	1.6069	51.0
37	71.050	1.5405 Q	497.0

QUARTZ  
+ CLAG. FELDSPAR  
+ KAOLINITE (MAYBE CATON)  
+ MUSCOVITE  
+ DOLOMITE?

10<sup>2</sup> 965-53



965-53

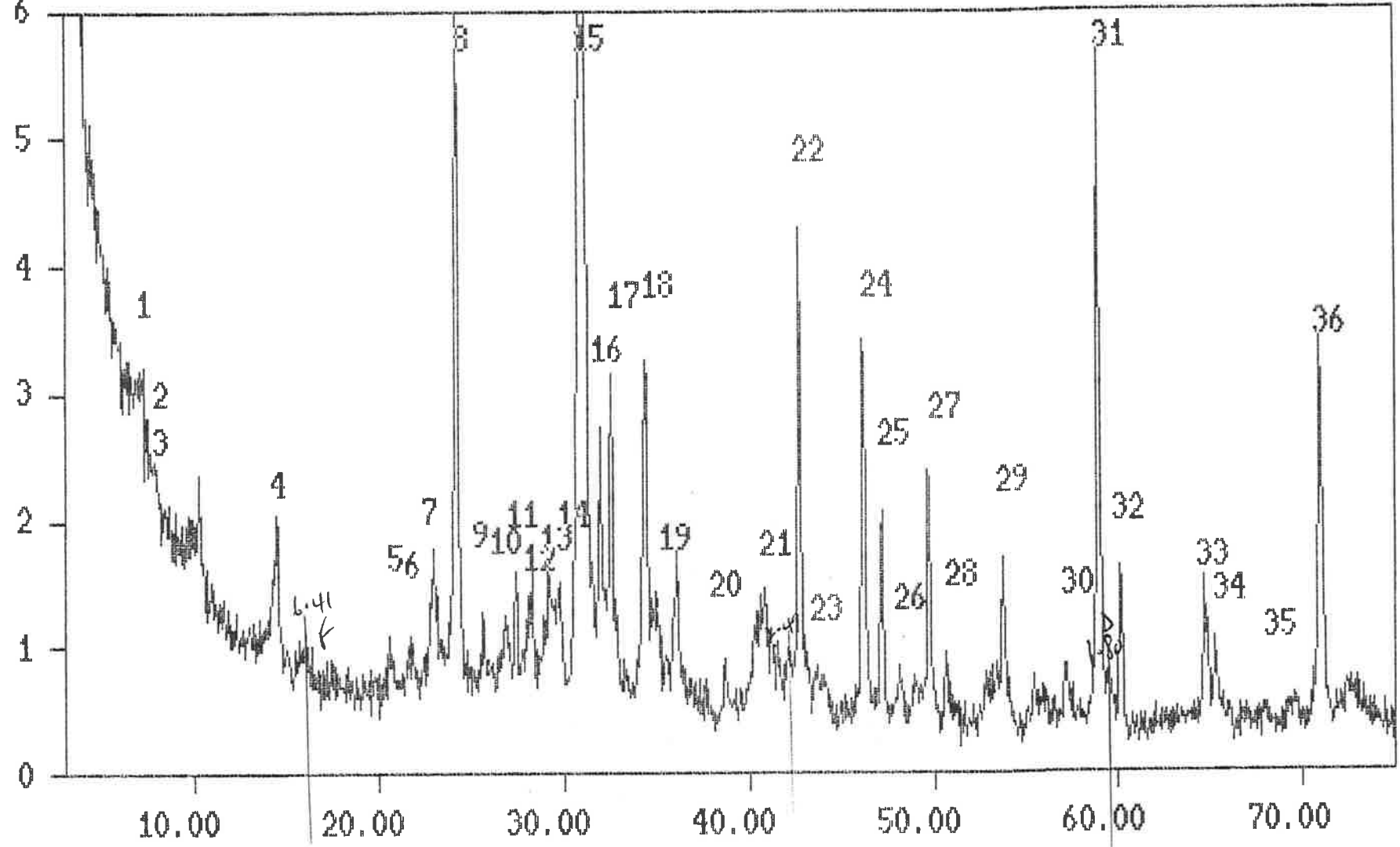
3  
75  
Co  
1.7902  
09-30-1991

SCH = 15 SENS = 1.0

M	2THETA	DSPACE	HEIGHT
1	7.600	13.5061	373.0
2	9.850	10.4261	281.0
3	10.200	10.0693 <sup>m</sup>	255.0
4	14.350	7.1665 <sup>K</sup>	199.0
5	20.600	5.0061 <sup>m</sup>	115.0
6	23.000	4.4897 <sup>mk</sup>	292.0
7	24.250	4.2615 <sup>Q</sup>	907.0
8	26.900	3.8483 <sup>K</sup>	138.0
9	27.450	3.7726 <sup>f</sup>	138.0
10	28.150	3.6806 <sup>mf</sup>	155.0
11	31.050	3.3442 <sup>Qm</sup>	4647.0
12	32.000	3.2474 <sup>f</sup>	267.0
13	32.600	3.1892 <sup>f</sup>	264.0
14	37.600	2.7775	101.0
15	40.750	2.5709 <sup>mk</sup>	198.0
16	42.700	2.4586 <sup>Q</sup>	381.0
17	44.950	2.3415 <sup>K</sup>	106.0
18	46.200	2.2815 <sup>Q</sup>	273.0
19	47.200	2.2358 <sup>Q</sup>	201.0
20	48.950	2.1605	94.0
21	49.800	2.1259 <sup>Q</sup>	250.0
22	53.750	1.9801 <sup>Q</sup>	188.0
23	59.000	1.8177 <sup>Q</sup>	507.0
24	64.750	1.6717 <sup>Q</sup>	215.0
25	71.000	1.5414 <sup>Q</sup>	341.0

QUARTZ  
+ MUSCOVITE  
+ PLAG. FELDSPAR (ALBITE-AN)  
+ KAOLINITE  
(MAYBE CHLORITE)

10<sup>2</sup> 6 965-54



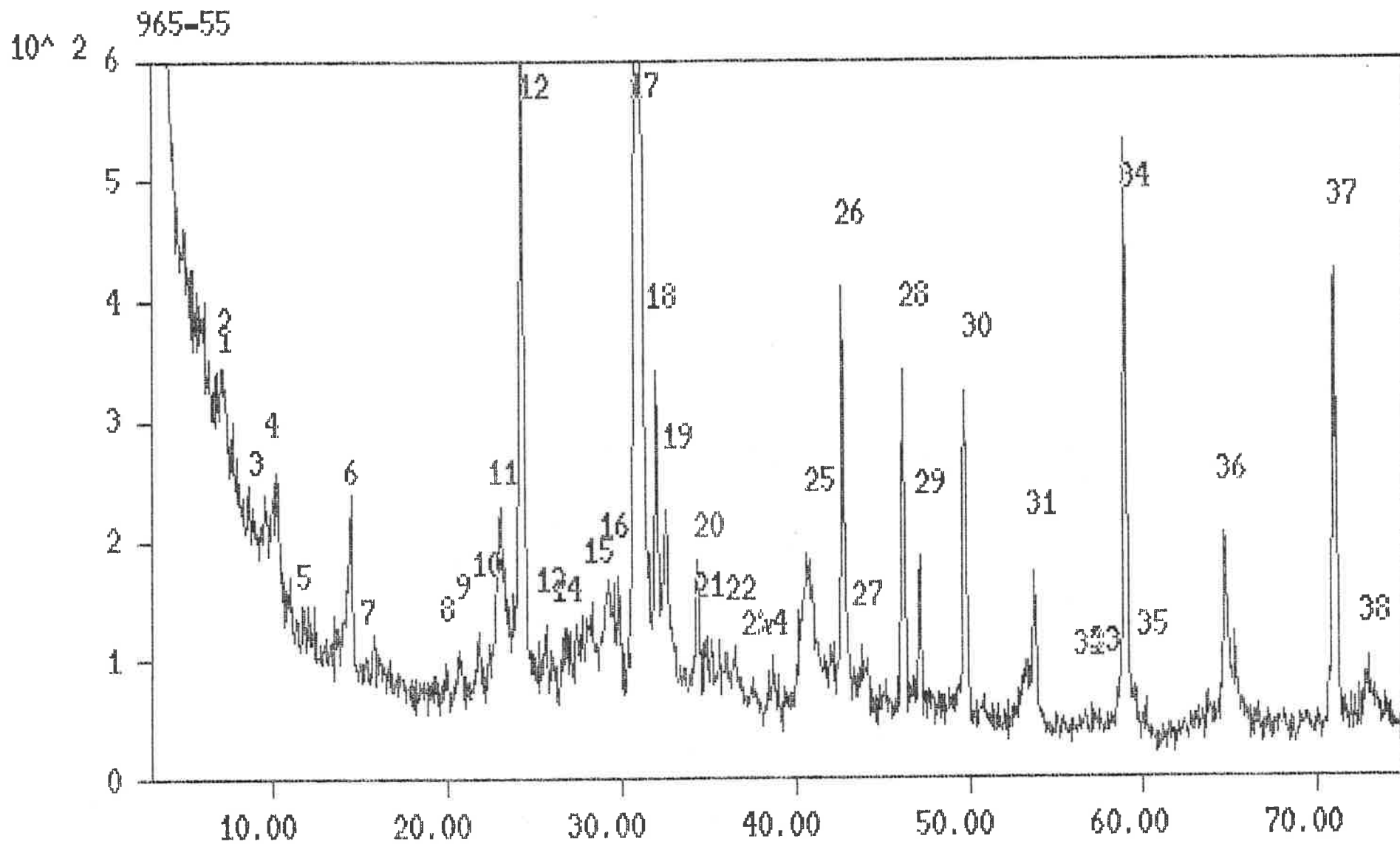
965-5A

3  
75  
Co  
1.7902  
09-30-1991

SCH = 15 SENS = 1.0

M	2THETA	DSPACE	HEIGHT
1	7.000	14.6621 <sup>CH</sup>	319.0
2	7.850	<del>13.0756</del>	246.0
3	8.500	<del>12.0782</del>	213.0
4	14.400	7.1418 <sup>CH</sup>	204.0
5	20.600	5.0061 <sup>m</sup>	109.0
6	21.700	4.7551 <sup>CH</sup>	108.0
7	22.900	4.5090 <sup>m</sup>	164.0
8	24.200	4.2701 <sup>Q</sup>	874.0
9	25.600	4.0402 <sup>f</sup>	128.0
10	26.900	3.8483 <sup>c</sup>	125.0
11	27.350	3.7862	158.0
12	28.150	3.6806 <sup>m</sup>	140.0
13	29.100	3.5629 <sup>CH</sup>	169.0
14	29.700	3.4925	150.0
15	31.000	3.3494 <sup>Qm</sup>	4082.0
16	31.950	3.2523 <sup>f</sup>	273.0
17	32.550	3.1940 <sup>f</sup>	315.0
18	34.350	3.0312 <sup>c</sup>	326.0
19	36.000	2.8966 <sup>d</sup>	172.0
20	38.600	2.7082	91.0
21	40.750	2.5709 <sup>CH</sup>	140.0
22	42.700	2.4586 <sup>Q</sup>	429.0
23	44.100	2.3843	77.0
24	46.150	2.2838 <sup>Qc</sup>	343.0
25	47.150	2.2380 <sup>Q</sup>	206.0
26	48.100	2.1964 <sup>d</sup>	84.0
27	49.700	2.1300 <sup>Q</sup>	239.0
28	50.650	2.0926 <sup>c</sup>	96.0
29	53.750	1.9801 <sup>Q</sup>	169.0
30	57.150	1.8714 <sup>c</sup>	86.0
31	58.950	1.8191 <sup>Q</sup>	575.0
32	60.200	1.7848 <sup>d</sup>	162.0
33	64.700	1.6728 <sup>Q</sup>	153.0
34	65.350	1.6580 <sup>Q</sup>	105.0
35	68.000	1.6007 <sup>c</sup>	54.0
36	70.950	1.5424 <sup>Q</sup>	344.0

QUARTZ  
+ PLAG. FELDSPAR  
+ FLUORITE (CLINOCHLOR) (An K)  
+ MICA (MUSCOVITE)  
+ CALCITE  
+ DOLOMITE



965 - 55

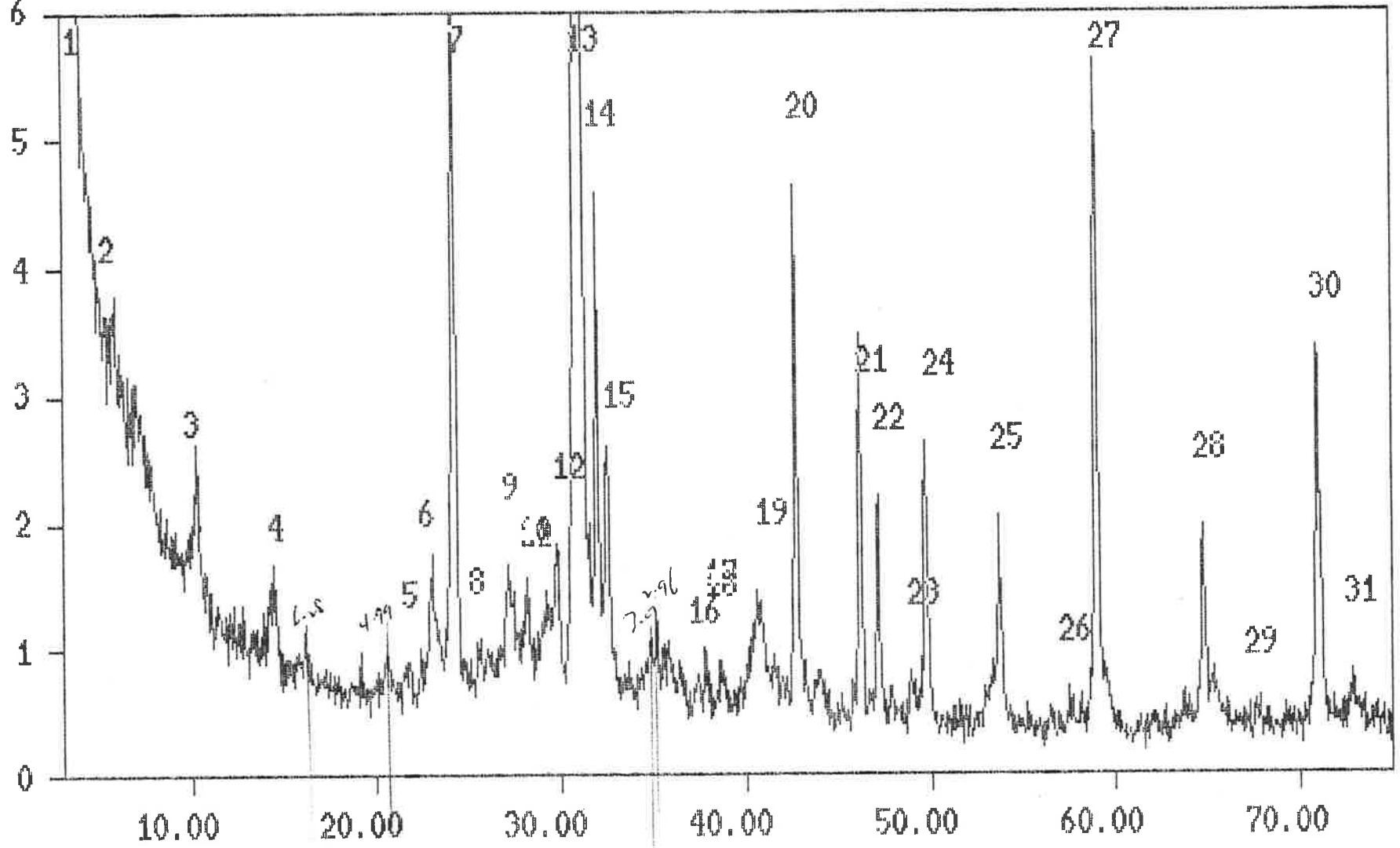
3  
75  
Co  
1.7902  
09-30-1991

SCH = 15 SENS = 1.0

N	2THETA	DSPACE	HEIGHT
1	7.000	14.6621	344.0
2	7.150	14.3549	346.0
3	9.500	<del>10.8093</del>	239.0
4	10.150	10.1187	257.0
5	11.900	8.6349	141.0
6	14.400	7.1418	202.0
7	15.900	6.4717	121.0
8	19.850	5.1932	99.0
9	20.600	5.0061	110.0
10	21.750	4.7443	125.0
11	23.000	4.4897	227.0
12	24.250	4.2615	1206.0
13	25.550	4.0480	113.0
14	26.700	3.8766	126.0
15	28.150	3.6806	138.0
16	29.100	3.5629	156.0
17	31.000	3.3494	4563.0
18	31.950	3.2523	343.0
19	32.550	3.1940	226.0
20	34.300	3.0355	182.0
21	34.950	2.9808	120.0
22	36.550	2.8545	112.0
23	37.550	2.7811	84.0
24	38.600	2.7082	89.0
25	40.650	2.5770	188.0
26	42.750	2.4559	410.0
27	43.950	2.3920	111.0
28	46.150	2.2838	342.0
29	47.200	2.2358	186.0
30	49.750	2.1279	323.0
31	53.750	1.9801	173.0
32	56.600	1.8880	51.0
33	57.300	1.8669	60.0
34	58.950	1.8191	532.0
35	60.150	1.7862	65.0
36	64.700	1.6728	205.0
37	71.000	1.5414	425.0
38	72.850	1.5075	102.0

QUARTZ  
+ PLAG. FELDSPAR  
+ CHLORITE (CLINOCHLORITE) (AND KA)  
+ MUSCOVITE  
+ CALCITE

10<sup>2</sup> 6 965-56





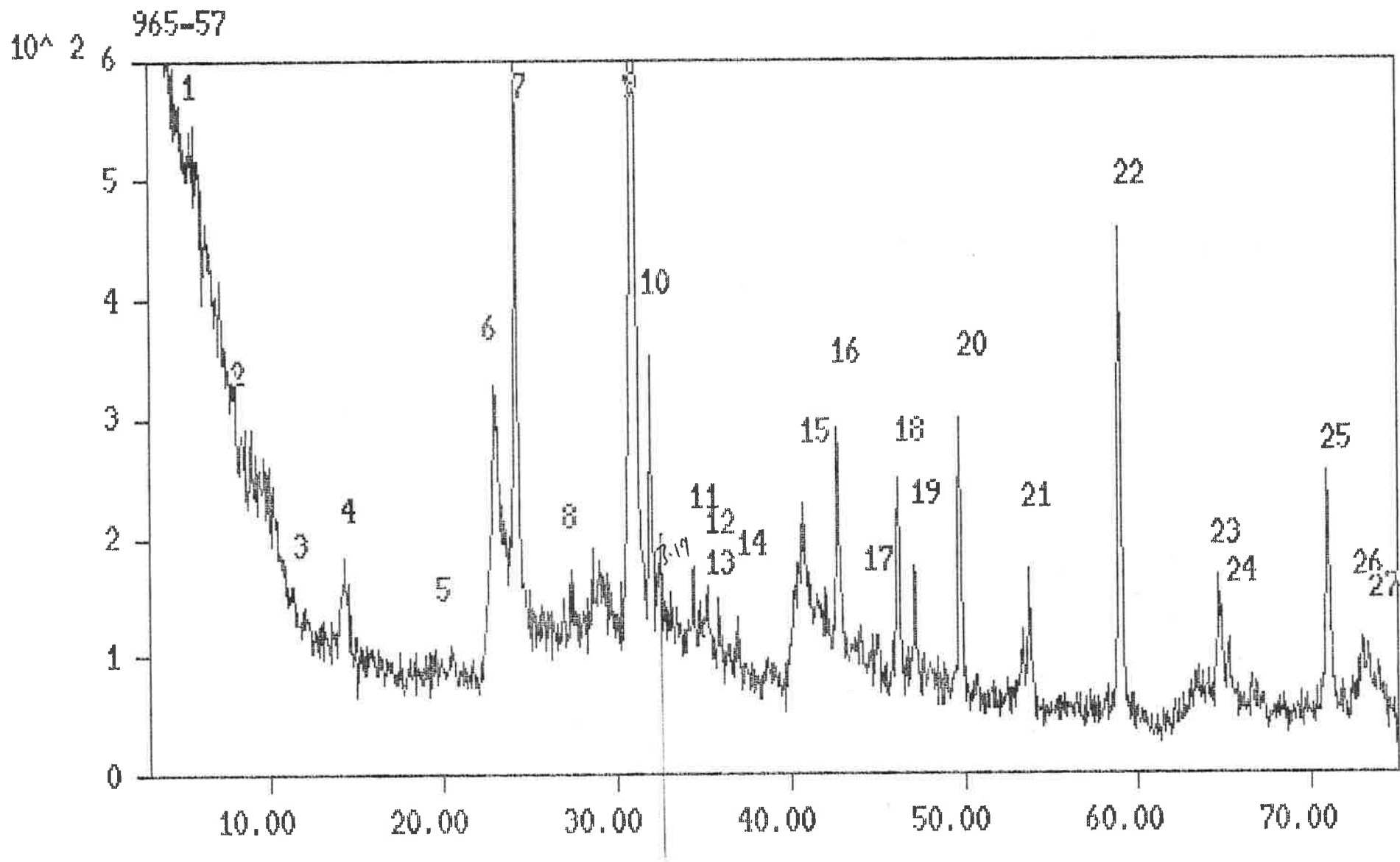
965-56

3  
75  
Co  
1.7902  
09-30-1991

SCH = 15 SENS = 1.0

M	2THETA	DSPACE	HEIGHT
1	3.550	<del>28.8978</del>	1325.0
2	5.800	<del>17.6922</del>	379.0
3	10.250	10.0203 <sup>m</sup>	262.0
4	14.350	7.1665 <sup>ch</sup>	154.0
5	21.700	4.7551 <sup>ch</sup>	90.0
6	22.950	4.4993 <sup>m</sup>	146.0
7	24.250	4.2615 <sup>Q</sup>	1070.0
8	25.550	4.0480 <sup>f</sup>	106.0
9	27.200	3.8066	167.0
10	28.100	3.6871 <sup>mf</sup>	157.0
11	28.250	3.6679 <sup>mf</sup>	140.0
12	29.800	3.4811	183.0
13	31.000	3.3494 <sup>Qm</sup>	6992.0
14	31.950	3.2523 <sup>f</sup>	458.0
15	32.500	3.1987 <sup>f</sup>	261.0
16	37.350	2.7954	77.0
17	37.850	2.7598	102.0
18	38.650	2.7048	91.0
19	40.650	2.5770 <sup>mf</sup>	145.0
20	42.700	2.4586 <sup>Qt</sup>	465.0
21	46.200	2.2815 <sup>Q</sup>	348.0
22	47.150	2.2380 <sup>Q</sup>	220.0
23	48.950	2.1605 <sup>m</sup>	83.0
24	49.750	2.1279 <sup>Q</sup>	262.0
25	53.750	1.9801 <sup>Q</sup>	205.0
26	57.500	1.8610	68.0
27	58.950	1.8191 <sup>Q</sup>	563.0
28	64.750	1.6717 <sup>Q</sup>	197.0
29	67.650	1.6080 <sup>Q</sup>	59.0
30	71.000	1.5414 <sup>Q</sup>	337.0
31	72.800	1.5084	82.0

QUARTZ  
+ PLAG FELDSPAR (ALBITE - ANORTH)  
+ MUSCOVITE  
+ CHLORITE (+ KAOLINITE?)



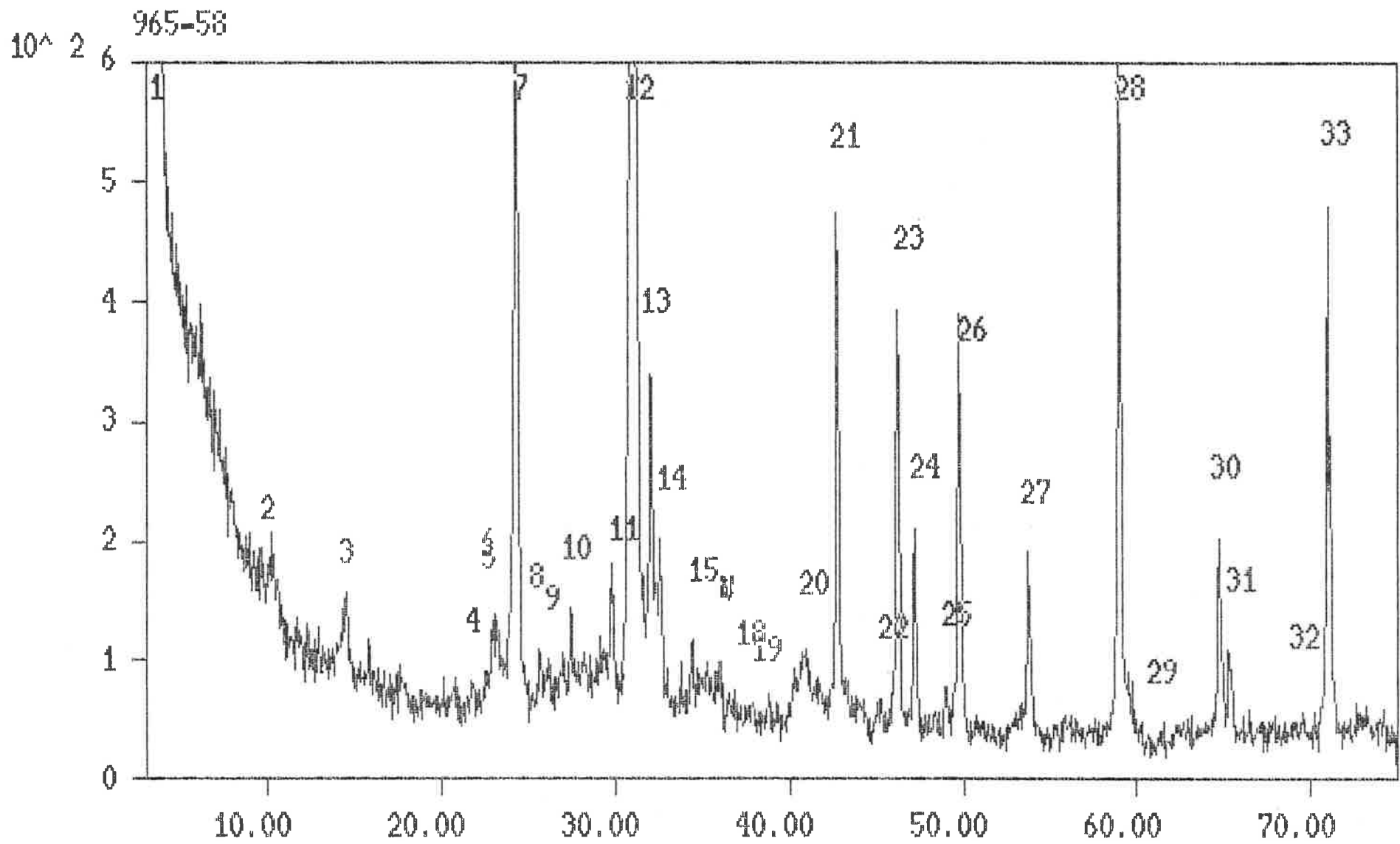
965 - 57

3  
75  
Co  
1.7902  
09-30-1991

SCH = 11 SENS = 2.0

M	2THETA	DSPACE	HEIGHT
1	5.900	<del>17.3926</del>	516.0
2	8.500	<del>12.0782</del>	286.0
3	12.100	<del>8.4927</del>	140.0
4	14.200	7.2418	163.0
5	20.500	5.0302	108.0
6	23.050	4.4801	328.0
7	24.250	4.2615	714.0
8	27.450	3.7726	172.0
9	31.000	3.3494	3672.0
10	31.950	3.2523	353.0
11	34.350	3.0312	174.0
12	35.200	2.9603	159.0
13	35.900	2.9044	148.0
14	36.950	2.8246	133.0
15	40.750	2.5709	227.0
16	42.700	2.4586	293.0
17	45.000	2.3390	118.0
18	46.200	2.2815	250.0
19	47.100	2.2403	174.0
20	49.750	2.1279	299.0
21	53.750	1.9801	172.0
22	58.950	1.8191	460.0
23	64.750	1.6717	166.0
24	65.250	1.6602	113.0
25	71.000	1.5414	254.0
26	72.950	1.5057	115.0
27	73.900	1.4891	94.0

QUARTZ  
+ MICA (MUSCOVITE)  
+ KAOLINITE (OR POSSIBLY CATO  
BUT 14A PEAK N:  
APPARENT)  
+ FELDSPAR  
+ CALCITE  
+ DOLOMITE



965-58

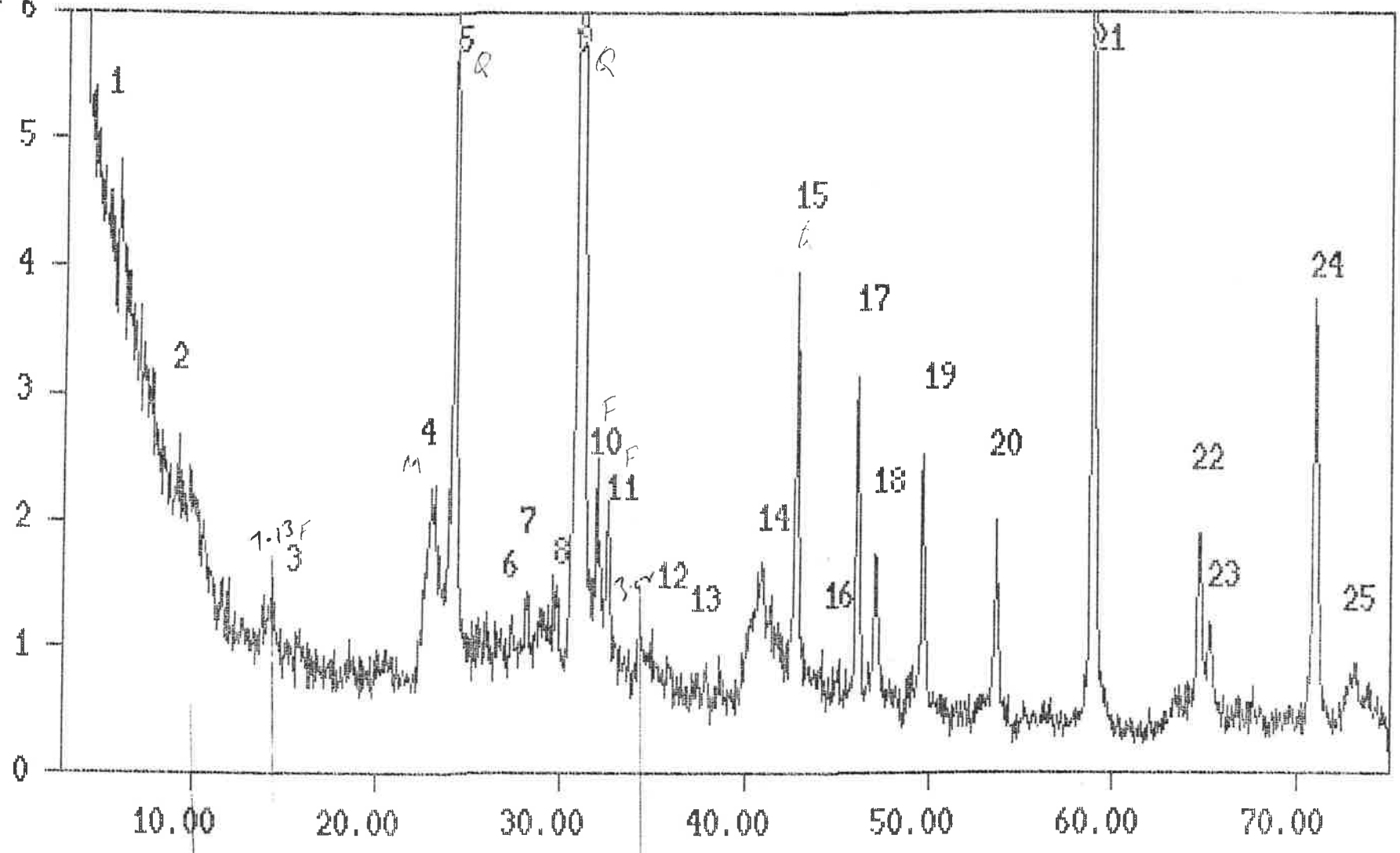
3  
75  
Ca  
1.7902  
09-30-1991

SCH = 15 SENS = 1.0

M	2THETA	DSPACE	HEIGHT
1	3.500	<del>29.3105</del>	1376.0
2	10.200	10.0693 <sup>M</sup>	207.0
3	14.450	7.1172 <sup>CH</sup>	150.0
4	21.700	4.7551 <sup>CH</sup>	82.0
5	22.900	4.5090	132.0
6	23.050	4.4801 <sup>M</sup>	138.0
7	24.250	4.2615 <sup>Q</sup>	1411.0
8	25.600	4.0402 <sup>F</sup>	109.0
9	26.900	3.8483 <sup>C</sup>	106.0
10	27.450	3.7726	143.0
11	29.800	3.4811	180.0
12	31.050	3.3442 <sup>Q</sup>	6000.0
13	32.050	3.2424 <sup>F</sup>	339.0
14	32.550	3.1940 <sup>F</sup>	202.0
15	34.350	3.0312 <sup>C</sup>	118.0
16	35.300	2.9522	99.0
17	35.950	2.9005 <sup>D</sup>	98.0
18	37.750	2.7669	62.0
19	38.750	2.6981	72.0
20	40.850	2.5649	107.0
21	42.750	2.4559 <sup>Q</sup>	476.0
22	45.100	2.3341	65.0
23	46.200	2.2815 <sup>Q</sup>	392.0
24	47.200	2.2358 <sup>Q</sup>	210.0
25	49.000	2.1585 <sup>M</sup>	78.0
26	49.750	2.1279 <sup>Q</sup>	391.0
27	53.800	1.9784 <sup>Q</sup>	192.0
28	59.000	1.8177 <sup>Q</sup>	599.0
29	61.400	1.7532	39.0
30	64.750	1.6717 <sup>Q</sup>	202.0
31	65.350	1.6580 <sup>Q</sup>	107.0
32	69.600	1.5684	57.0
33	71.000	1.5414 <sup>Q</sup>	480.0

QUARTZ  
+ PLAG. FELDSPAR  
+ MUSCOVITE  
+ CHLORITE (+ POSSIBLY ALSO KA)  
+ CALCITE  
+ DELONITE

10<sup>2</sup> 6 965-59



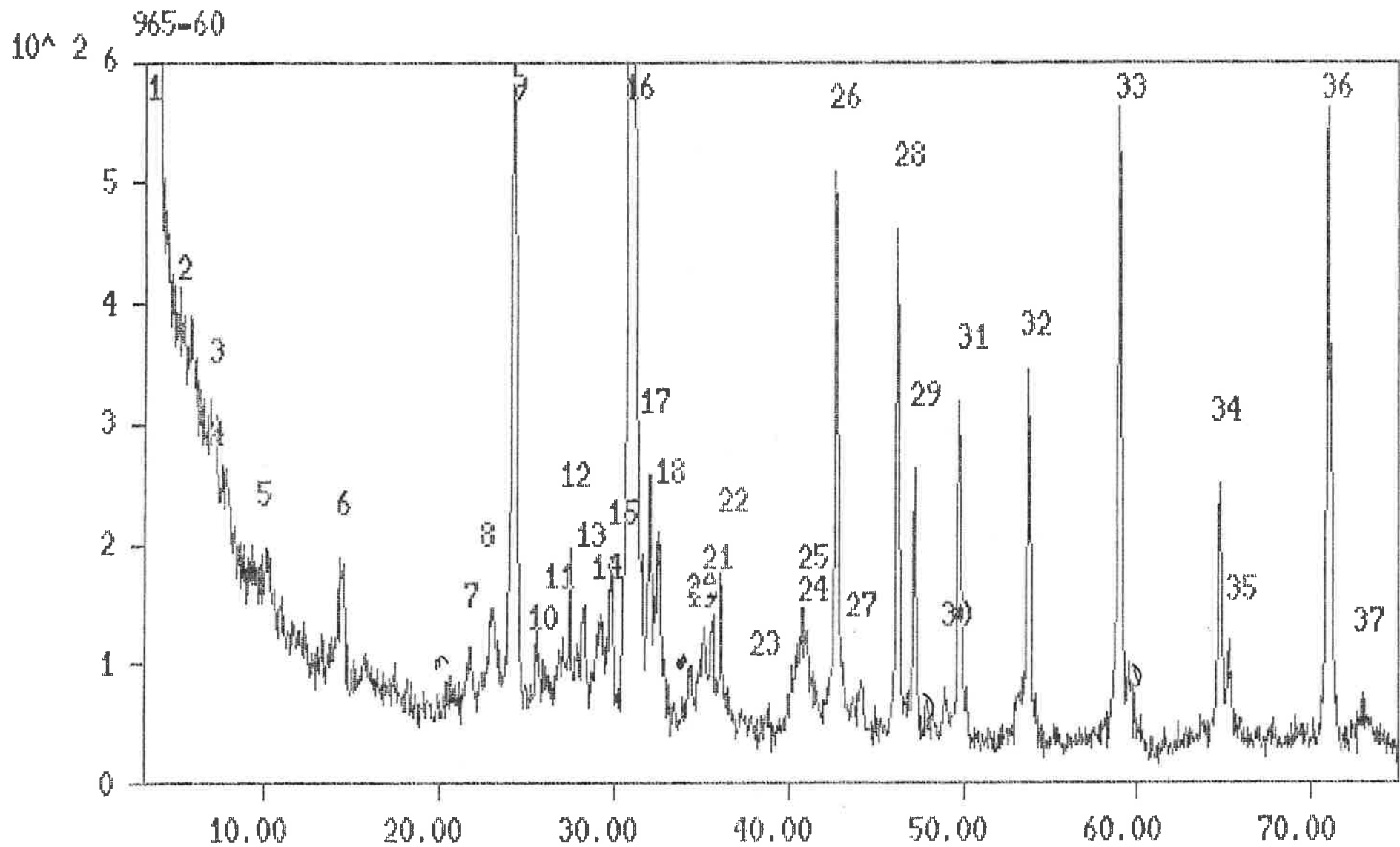
965 - 59

3  
75  
Co  
1.7902  
09-30-1991

SCH = 15 SENS = 1.0

M	2THETA	DSPACE	HEIGHT
1	5.850	<del>17.6411</del>	482.0
2	9.050	11.3456	268.0
3	15.800	6.5124 <sup>F</sup>	114.0
4	22.950	4.4993 <sup>m</sup>	226.0
5	24.200	4.2701 <sup>Q</sup>	712.0
6	27.500	3.7659	124.0
7	28.150	3.6806	144.0
8	29.700	3.4925	156.0
9	31.000	3.3494 <sup>Q</sup>	3946.0
10	31.900	3.2573 <sup>F</sup>	250.0
11	32.500	3.1987 <sup>F</sup>	218.0
12	35.800	2.9123 <sup>D</sup>	94.0
13	37.800	2.7634	82.0
14	40.750	2.5709	160.0
15	42.650	2.4614 <sup>Q</sup>	394.0
16	44.950	2.3415	87.0
17	46.150	2.2838 <sup>Q</sup>	313.0
18	47.150	2.2380 <sup>Q</sup>	172.0
19	49.700	2.1300 <sup>Q</sup>	251.0
20	53.700	1.9818 <sup>Q</sup>	199.0
21	58.950	1.8191 <sup>Q</sup>	806.0
22	64.700	1.6728 <sup>Q</sup>	189.0
23	65.300	1.6591 <sup>Q</sup>	120.0
24	70.950	1.5424 <sup>Q</sup>	373.0
25	73.050	1.5039	87.0

QUARTZ  
+ FELDSPAR  
+ MUSCOVITE  
+ KAOLINITE  
+ DOLOMITE } TRAILS  
+ CALCITE }





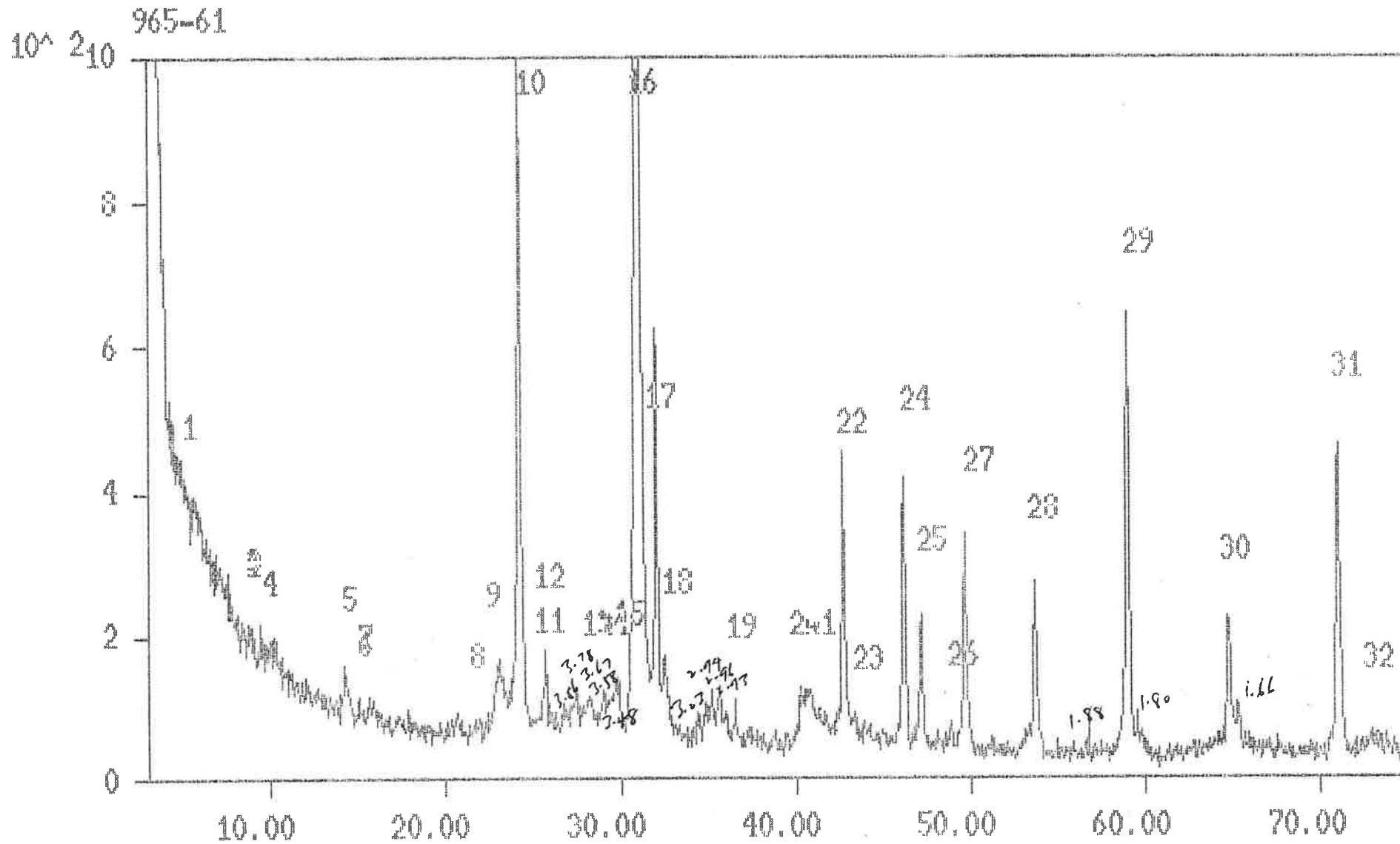
965-60

3  
75  
Co  
1.7902  
09-30-1991

SCH = 15 SENS = 1.0

M	2THETA	DSPACE	HEIGHT
1	3.500	<del>27.3165</del>	1432.0
2	5.900	<del>17.3926</del>	391.0
3	7.050	14.5582	303.0
4	7.750	13.2451	259.0
5	10.200	10.0693	197.0
6	14.450	7.1172	187.0
7	21.750	4.7443	114.0
8	22.950	4.4993	147.0
9	24.250	4.2615	1241.0
10	25.500	4.0558	131.0
11	26.900	3.8483	111.0
12	27.450	3.7726	195.0
13	28.200	3.6742	145.0
14	29.100	3.5629	135.0
15	29.750	3.4868	187.0
16	31.050	3.3442	5677.0
17	32.050	3.2424	258.0
18	32.500	3.1987	210.0
19	34.300	3.0355	97.0
20	35.000	2.9767	106.0
21	35.600	2.9281	140.0
22	36.100	2.8888	175.0
23	38.650	2.7048	56.0
24	40.650	2.5770	132.0
25	40.900	2.5619	146.0
26	42.750	2.4559	510.0
27	44.100	2.3843	86.0
28	46.200	2.2815	461.0
29	47.150	2.2380	263.0
30	48.900	2.1626	80.0
31	49.750	2.1279	319.0
32	53.750	1.9801	344.0
33	59.000	1.8177	562.0
34	64.750	1.6717	250.0
35	65.350	1.6580	119.0
36	71.000	1.5414	562.0
37	72.900	1.5066	75.0

QUARTZ  
+ CHLORITE (KAOLINITE A PO  
+ PLAG FELDSPAR  
+ MUSCOVITE  
+ DOLOMITE  
+ CALCITE



965 - 61

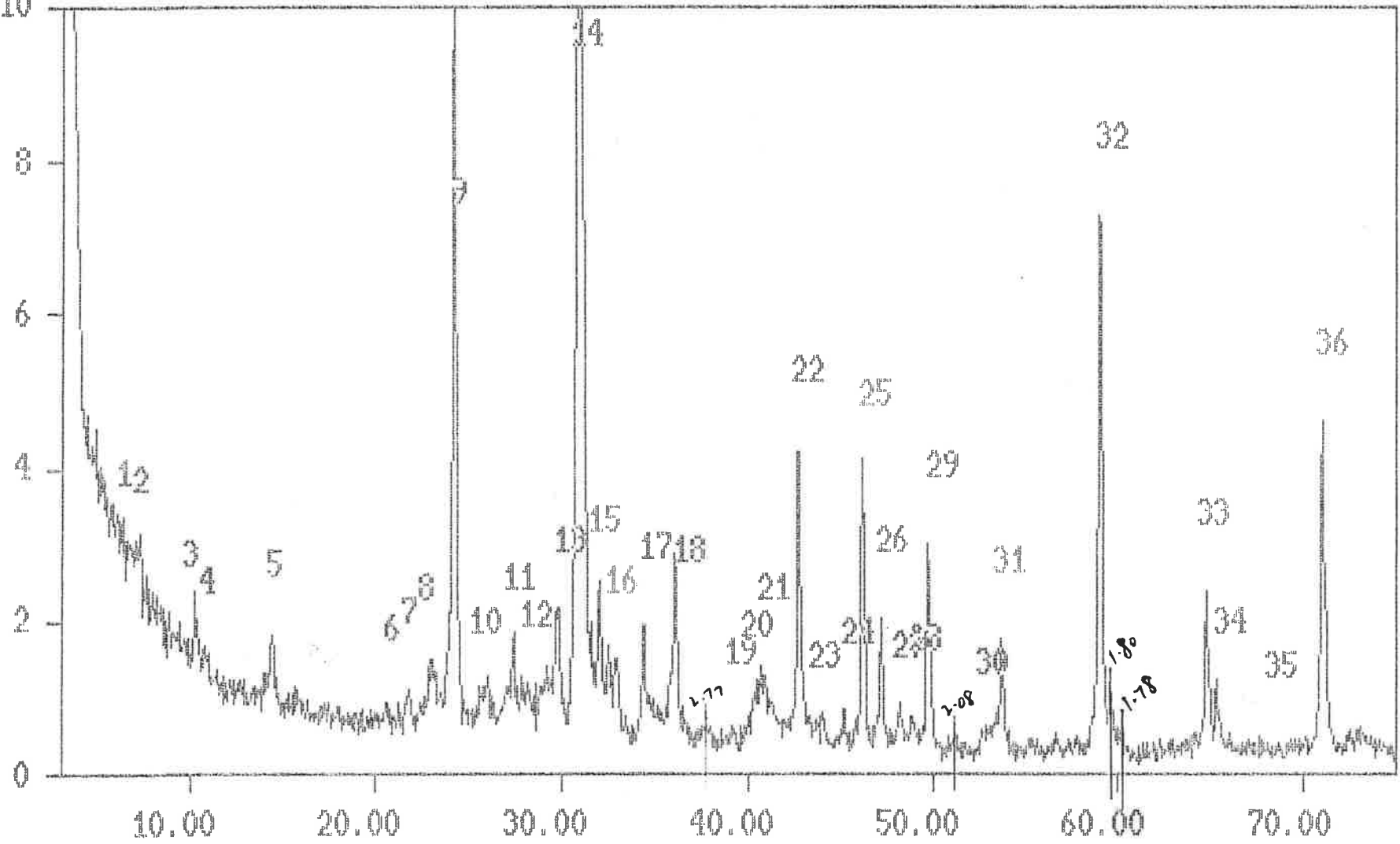
3  
75  
Co  
1.7902  
09-30-1991

SCH = 15 SENS = 1.0

M	2THETA	DSPACE	HEIGHT
1	5.800	<del>17.5722</del>	392.0
2	8.850	<del>11.4015</del>	215.0
3	9.450	<del>10.8664</del>	215.0
4	10.250	10.0203 <sup>m</sup>	199.0
5	14.300	7.1914 <sup>CHK</sup>	161.0
6	15.100	6.8125	113.0
7	15.800	6.5124 <sup>F</sup>	116.0
8	21.800	4.7334 <sup>CH</sup>	85.0
9	23.000	4.4897 <sup>CHK</sup>	168.0
10	24.200	4.2701 <sup>Q</sup>	1296.0
11	25.550	4.0480 <sup>F</sup>	121.0
12	25.700	4.0247	181.0
13	28.200	3.6742 <sup>F</sup>	116.0
14	29.050	3.5689 <sup>FK</sup>	122.0
15	29.750	3.4868 <sup>F</sup>	141.0
16	31.000	3.3494 <sup>Q</sup>	6020.0
17	32.000	3.2474 <sup>F</sup>	623.0
18	32.550	3.1940 <sup>F</sup>	173.0
19	36.550	2.8545 <sup>CH</sup>	110.0
20	40.350	2.5953 <sup>CH</sup>	128.0
21	40.750	2.5709 <sup>F</sup>	124.0
22	42.700	2.4586 <sup>Q</sup>	456.0
23	44.100	2.3843 <sup>CH</sup>	80.0
24	46.150	2.2838 <sup>Q</sup>	422.0
25	47.150	2.2380 <sup>Q</sup>	229.0
26	48.850	2.1647	78.0
27	49.700	2.1300 <sup>Q</sup>	340.0
28	53.700	1.9818 <sup>Q</sup>	272.0
29	58.950	1.8171 <sup>Q</sup>	647.0
30	64.750	1.6717 <sup>Q</sup>	224.0
31	71.000	1.5414 <sup>Q</sup>	466.0
32	72.950	1.5057 <sup>K</sup>	65.0

QUARTZ  
+ PLAGIOCLASE FELDSPAR  
+ ~~TRACE~~ LITTLE CHLORITE  
+ TRACE MICA  
+ LITTLE KAOLINITE  
+ ~~TRACE~~ LITTLE CALCITE  
+ ~~TRACE~~ LITTLE DOLOMITE  
+ ?

10<sup>4</sup> 210 965-62



965 - 62

3  
75  
Co  
1.7902  
09-30-1991

SCH = 15 SENS = 1.0

M	2THETA	DSPACE	HEIGHT
1	6.200	<del>14.5018</del>	327.0
2	7.100	14.4559 <i>CH</i>	303.0
3	10.200	10.0693 <i>m</i>	237.0
4	10.850	9.4677 <i>T</i>	166.0
5	14.350	7.1665 <i>CH</i>	181.0
6	20.550	5.0181 <i>M</i>	94.0
7	21.800	4.7334 <i>CH</i>	111.0
8	22.900	4.5090 <i>K</i>	151.0
9	24.250	4.2615 <i>Q</i>	1011.0
10	25.850	4.0018 <i>P</i>	117.0
11	27.400	3.7794 <i>F</i>	184.0
12	28.050	3.6935 <i>D</i>	129.0
13	29.800	3.4811 <i>F</i>	216.0
14	31.050	3.3442 <i>Q</i>	5689.0
15	32.050	3.2424 <i>F</i>	254.0
16	33.000	3.1516 <i>F</i>	150.0
17	34.400	3.0270 <i>C</i>	194.0
18	36.050	2.8927 <i>D</i>	288.0
19	39.200	2.6683 <i>D</i>	63.0
20	40.500	2.5861 <i>CH</i>	125.0
21	40.750	2.5709 <i>F</i>	141.0
22	42.750	2.4559 <i>Q</i>	422.0
23	43.950	2.3920 <i>F</i>	78.0
24	45.200	2.3292	86.0
25	46.200	2.2815 <i>Q</i>	409.0
26	47.200	2.2358 <i>Q</i>	204.0
27	48.150	2.1942 <i>S</i>	91.0
28	48.650	2.1647	73.0
29	49.800	2.1259 <i>Q</i>	299.0
30	52.850	2.0113 <i>S</i>	58.0
31	53.750	1.9801 <i>S</i>	176.0
32	59.000	1.8177 <i>S</i>	729.0
33	64.750	1.6717 <i>Q</i>	240.0
34	65.350	1.6580 <i>Q</i>	124.0
35	68.650	1.5874	39.0
36	71.000	1.5414 <i>Q<sub>ch</sub></i>	458.0

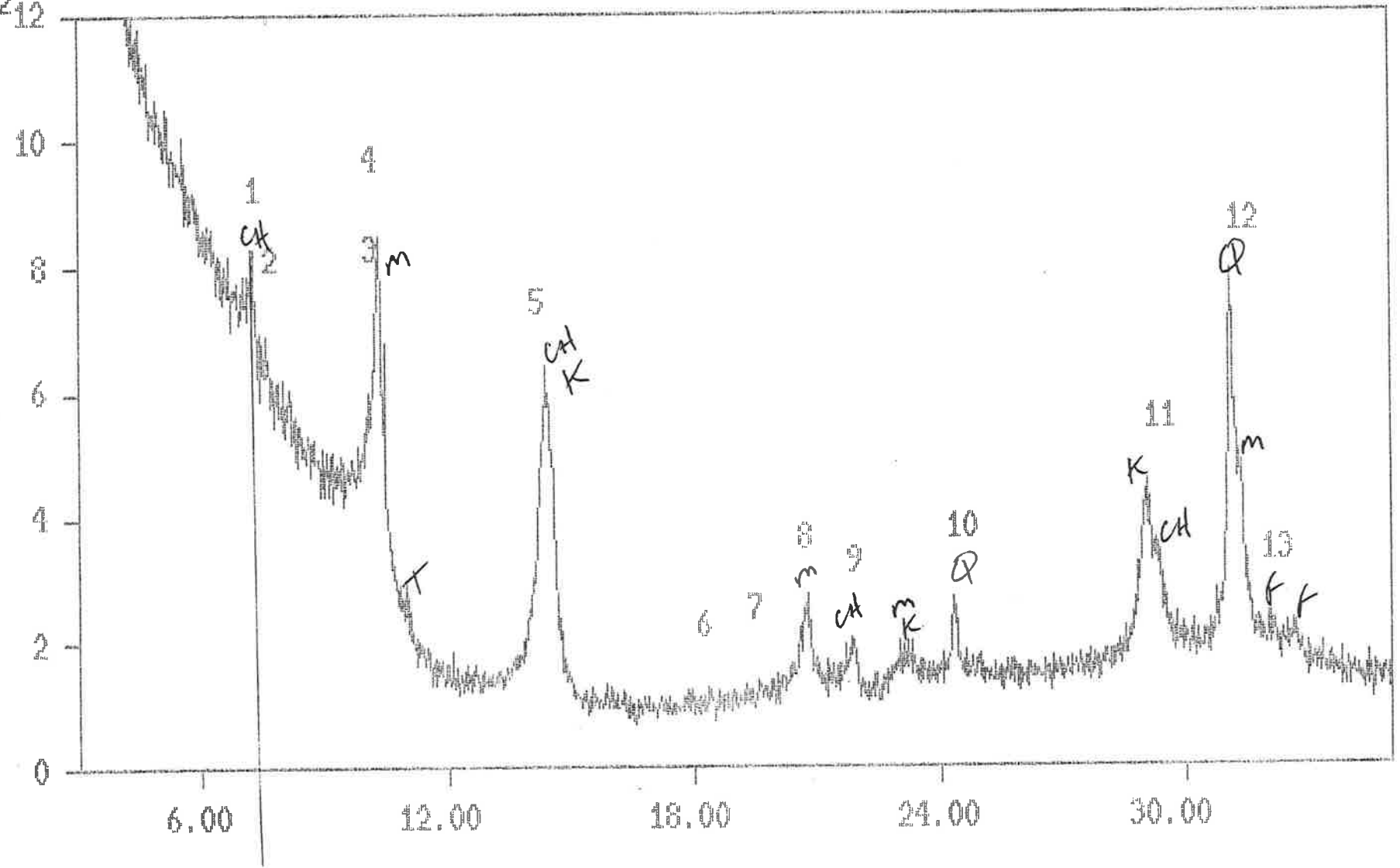
QUARTZ  
+ SOME DOLOMITE  
+ LITTLE PLAG. FELDSPAR  
+ LITTLE CHLORITE  
+ LITTLE KAOLINITE  
+ LITTLE CALCITE  
+ LITTLE MICA

APPENDIX VI

**X-RAY DIFFRACTION ANALYSIS: CLAY FRACTION OF SOIL SAMPLES,  
MAJOR ALLUVIAL FANS, WYACCA-EMEROO REGION**



965-51 (clay fraction)  
 $10^4 2_{12}$





965-21.2

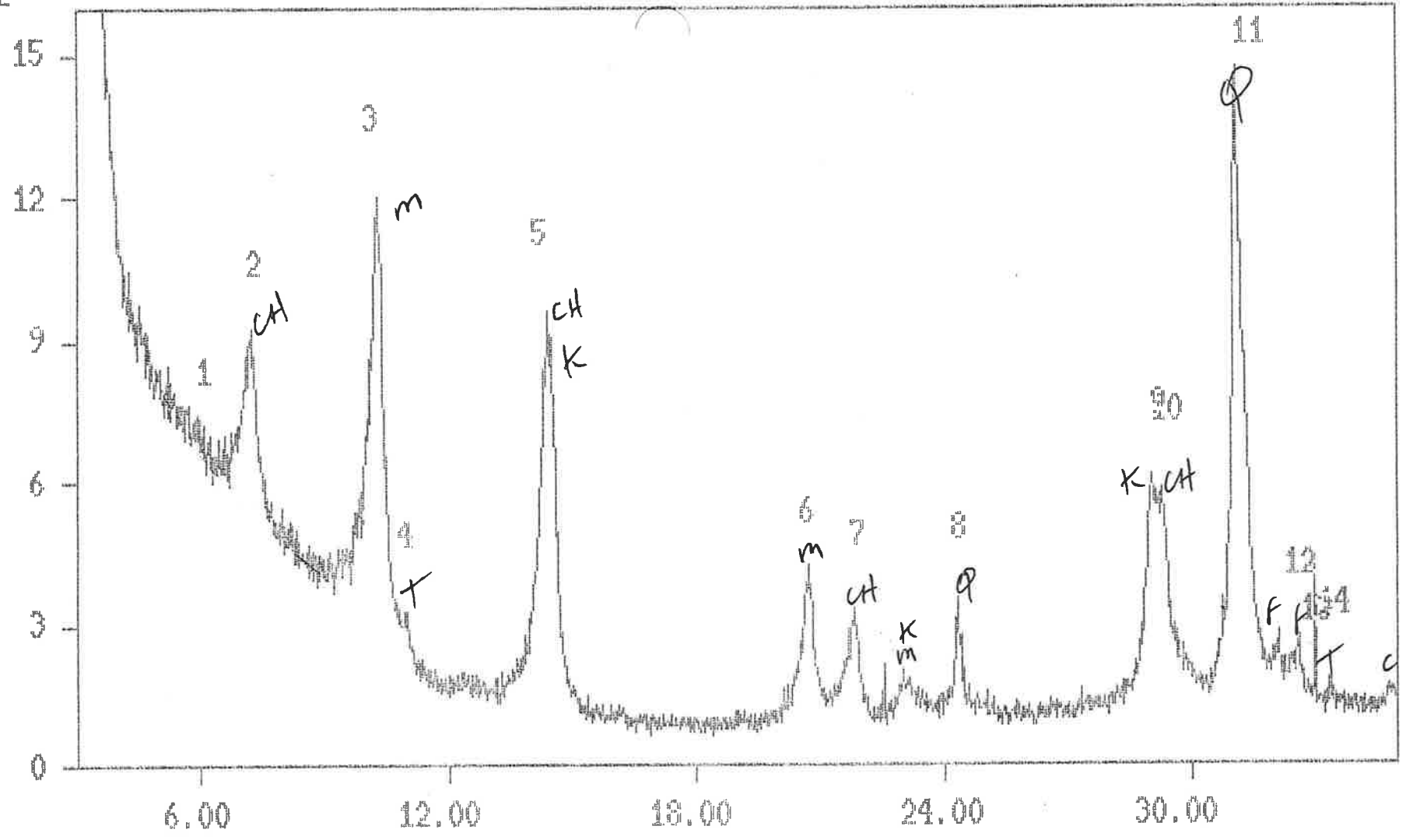
3  
35  
Ca  
1.7902  
10-29-1992

6CH = 19 SENS = 1.0

M	2THETA	DEPADE	HEIGHT
1	7.260	14.1377	800.0
2	7.620	13.4707	687.0
3	10.280	9.9911	756.0
4	10.340	9.9333	848.0
5	14.440	7.1321	641.0
6	18.380	5.6046	126.0
7	19.640	5.2482	137.0
8	20.720	4.9774	253.0
9	21.880	4.7165	207.0
10	24.320	4.2494	273.0
11	29.000	3.5750	437.0
12	31.100	3.3359	792.0
13	32.120	3.2356	252.0

MUSCOVITE  
+ KAOLINITE  
+ QUARTZ  
+ CLORITE  
+ FELDSPAR  
+ TALC?  
NO SMECTITE

10<sup>4</sup> 2 965-52 (clay fraction)



965-52c

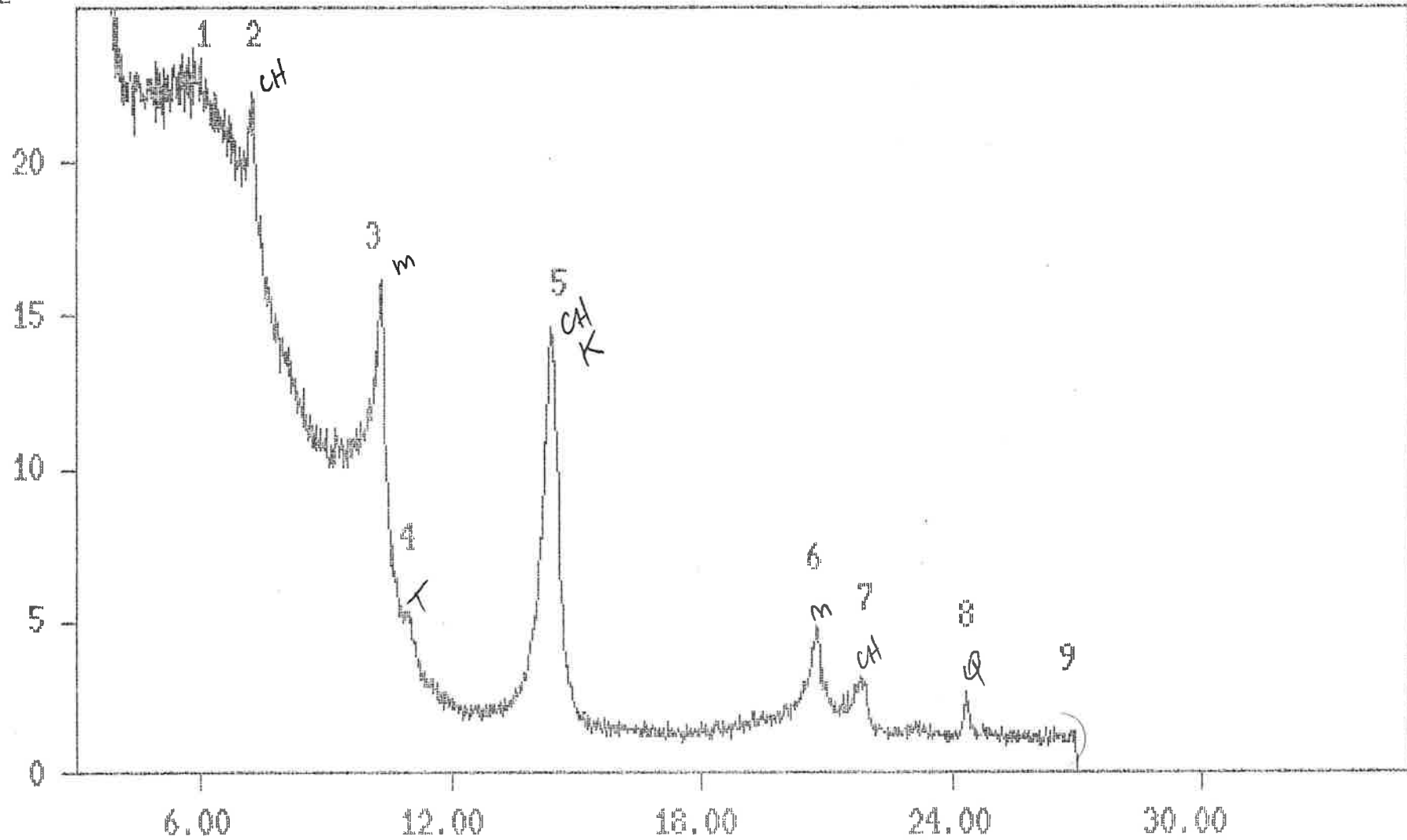
3  
35  
Cu  
1.7902  
10-29-1992

SCH = 19 SENS = 1.0

M	2THETA	DSPACE	HEIGHT
1	5.980	17.1601	740.0
2	7.240	14.1767	925.0
3	10.300	9.9718	1204.0
4	11.000	9.3390	324.0
5	14.440	7.1221	960.0
6	20.700	4.9822	427.0
7	21.820	4.7293	332.0
8	24.320	4.2494	357.0
9	29.020	3.5726	618.0
10	29.300	3.5392	585.0
11	31.080	3.3410	1470.0
12	32.400	3.1892	273.0
13	32.940	3.1572	154.0
14	33.360	3.1185	184.0

MUSCOVITE  
+ CLORITE  
+ KAOLINITE  
+ QUARTZ  
+ FELDSPAR  
+ CALCITE  
+ TALC  
SMELTITE CLAY?

10<sup>2</sup> 965-53 (clay fraction)



965-530

3  
35  
Cd  
1.7902  
10-29-1992

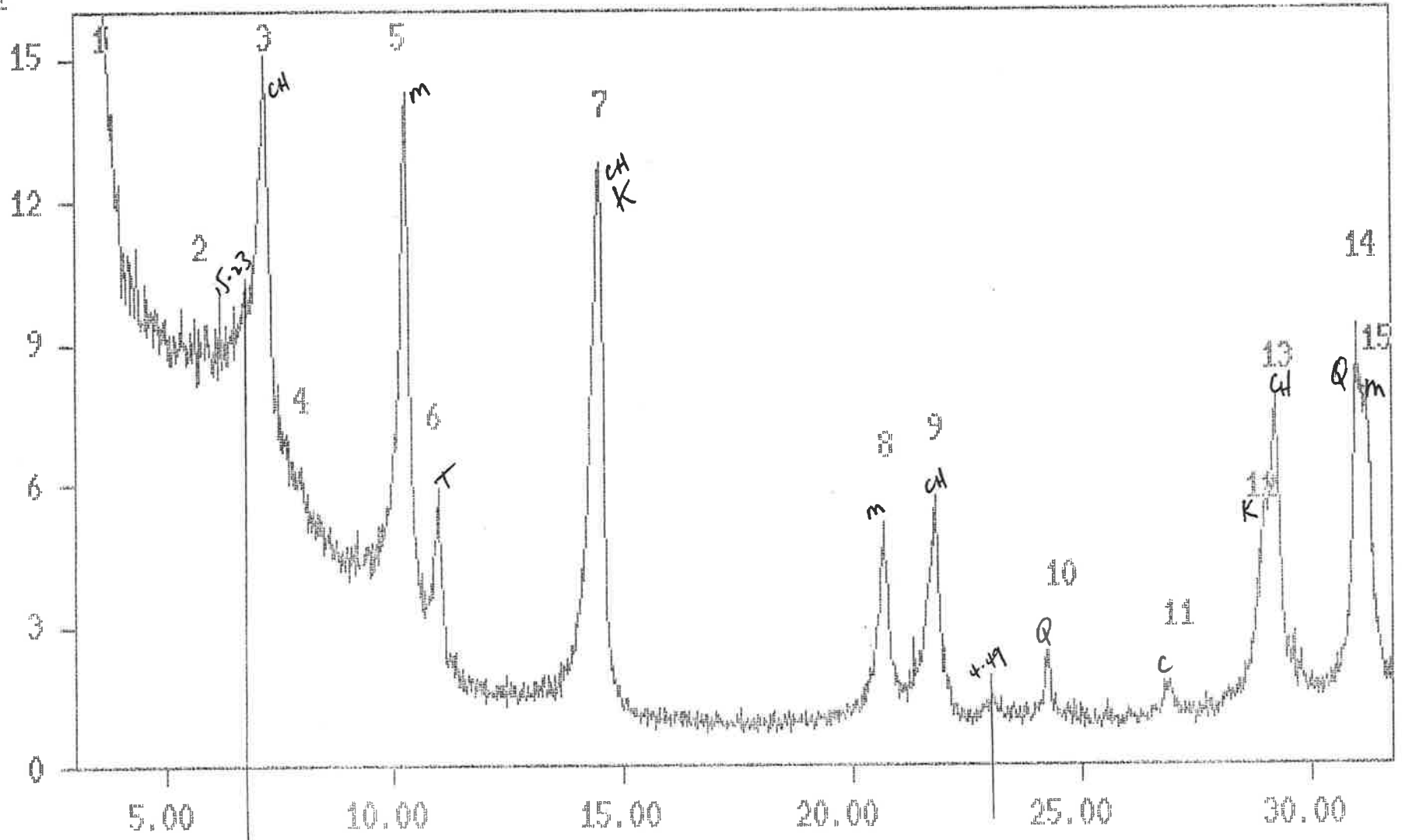
SCH = 19 SENS = 1.0

M	2THETA	DSPACE	HEIGHT
1	6.000	17.1030	2313.0
2	7.260	14.1377	2220.0
3	10.320	9.9525	1617.0
4	10.980	9.3559	533.0
5	14.460	7.1123	1457.0
6	20.720	4.9774	491.0
7	21.900	4.7336	324.0
8	24.320	4.2494	260.0
9	26.980	3.8511	129.0

CHLORITE  
+ KAOLINITE?  
+ MUSCOVITE  
+ QUARTZ  
+ TALC

SMECTITE CLAY

10<sup>2</sup> 965-54 (clay fraction)



965.54 c

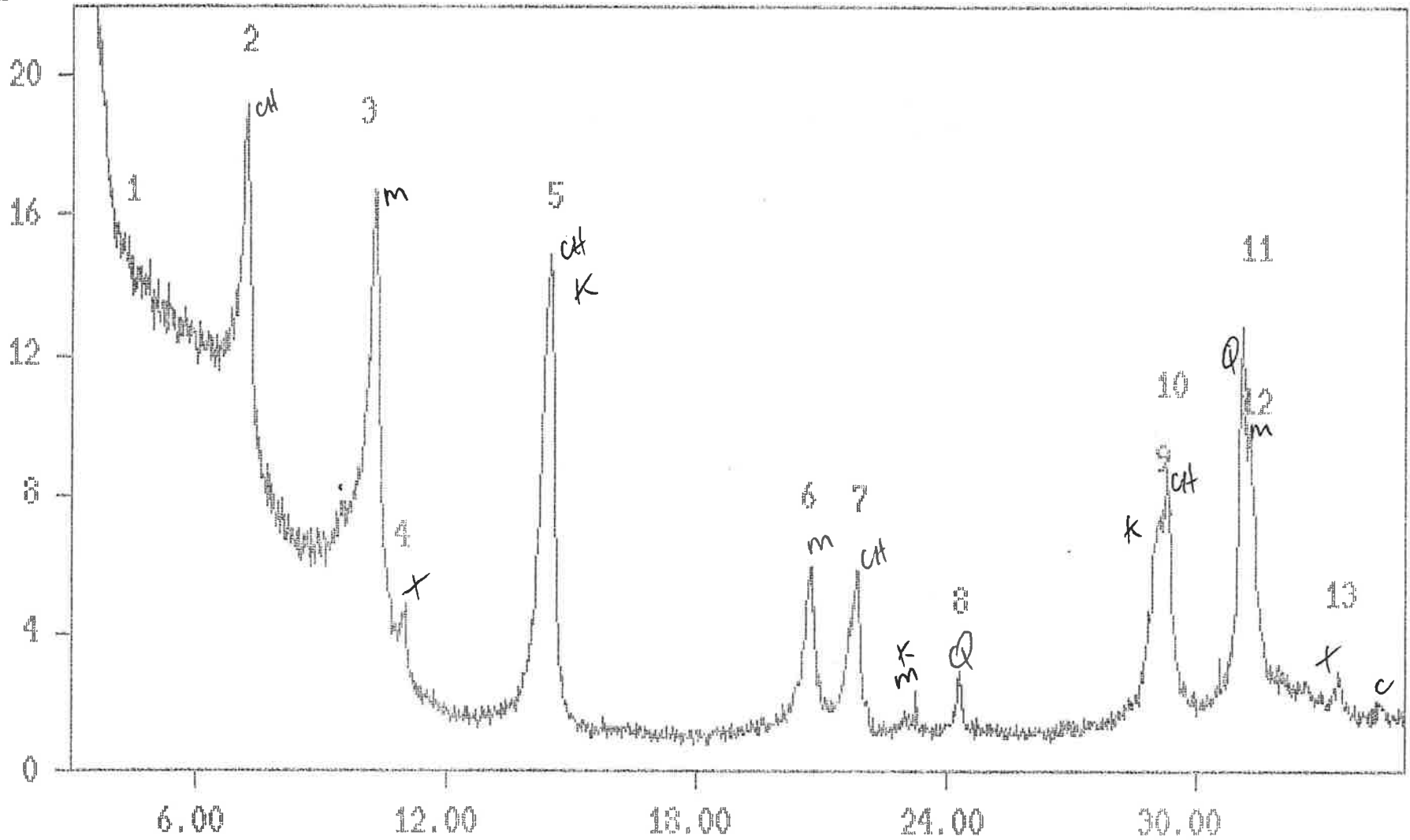
3  
35  
Co  
1.7902  
10-29-1992

SCH = 19 SENS = 1.0

M	2THETA	DSPACE	HEIGHT
1	3.480	29.4789	2010.0
2	5.900	17.3926	939.0
3	7.220	14.2159	1509.0
4	7.980	12.8639	640.0
5	10.260	10.0105	1399.0
6	10.960	9.3729	596.0
7	14.460	7.1123	1267.0
8	20.680	4.9869	517.0
9	21.800	4.7336	575.0
10	24.260	4.2597	240.0
11	26.880	3.8511	174.0
12	28.940	3.5822	511.0
13	29.220	3.5486	785.0
14	31.040	3.3452	934.0
15	31.260	3.3223	801.0
16	32.000	3.2474	246.0
17	32.500	3.1987	223.0
18	33.360	3.1185	350.0
19	34.380	3.0287	573.0

CHLORITE  
+ MUSCOVITE  
+ KAOLINITE  
+ TALC  
+ QUARTZ  
+ CALCITE  
+ FELDSPAR  
SMECTITE CLAY

10<sup>2</sup> 965-55 (clay fraction)





965.85c

35  
1.7902  
10-29-1992

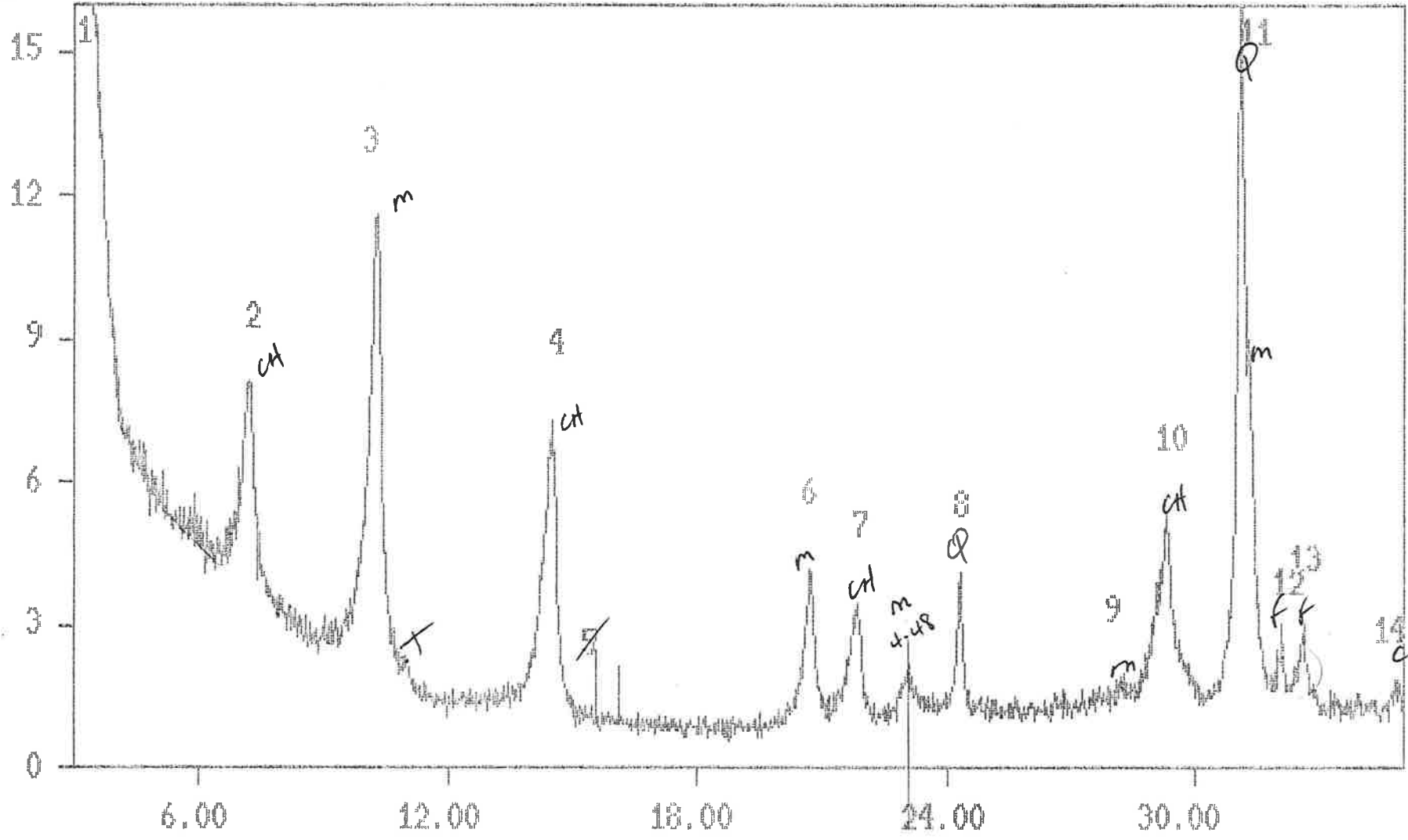
SDW = 19 SENS = 1.0

N	2THETA	DSPACE	HEIGHT
1	4.360	23.5311	1507.0
2	7.240	14.1767	1915.0
3	10.300	9.9718	1670.0
4	10.980	9.3859	456.0
5	14.500	7.0928	1488.0
6	20.720	4.9774	591.0
7	21.840	4.7250	583.0
8	24.300	4.2528	295.0
9	29.000	3.5750	707.0
10	29.300	3.5392	891.0
11	31.080	3.3410	1286.0
12	31.320	3.3161	975.0
13	33.380	3.1167	293.0

CEPHALITE  
+ KAOLINITE  
+ MUSCOVITE  
+ QUARTZ  
+ TALL  
+ CALCITE  
  
NO SMECTITE CLAY

10<sup>2</sup>

965-56 (clay fraction)



965.56c

3  
35  
Cu  
1.7902  
10-29-1992

SCN = 19 SENS = 1.0

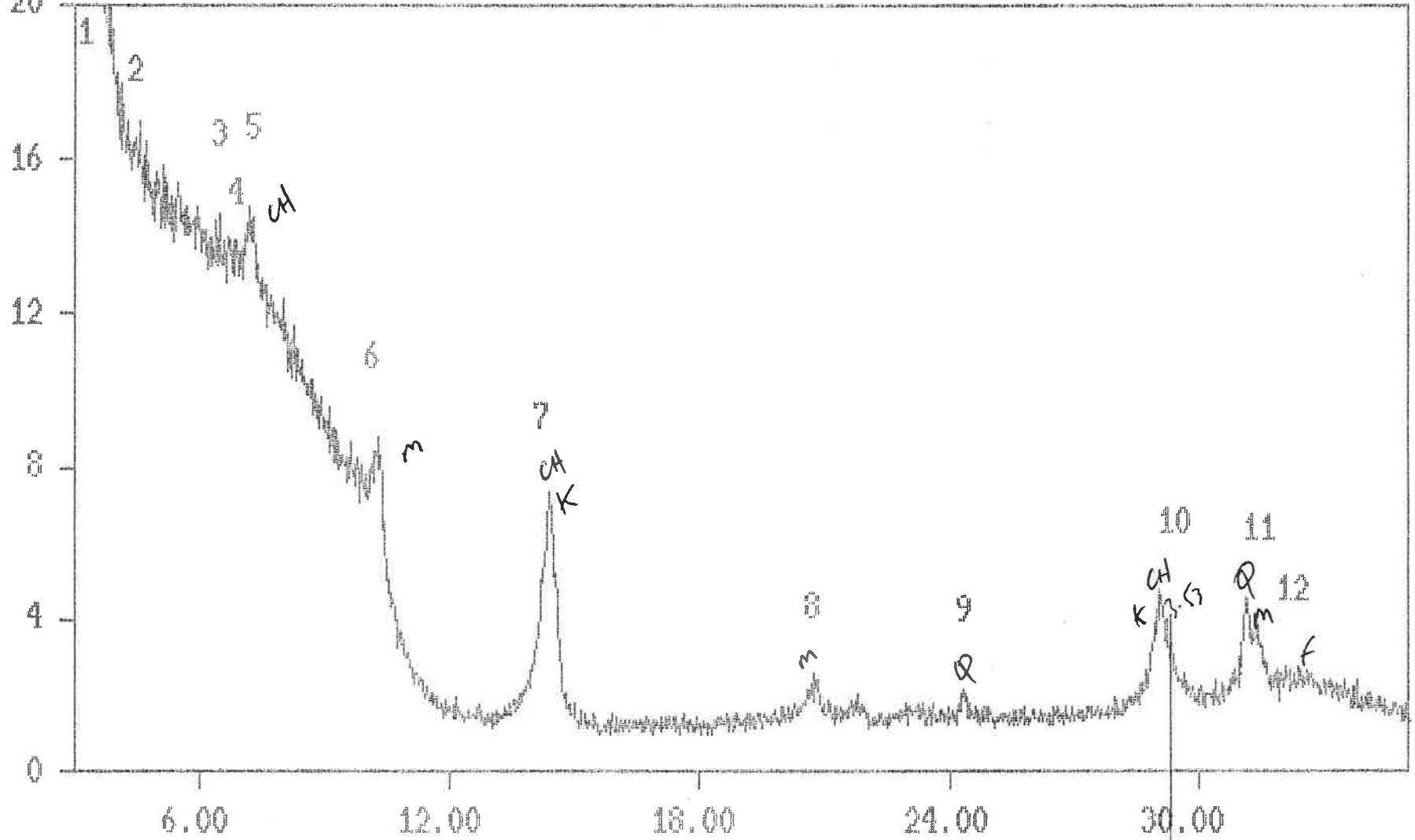
N	2THETA	DSPACE	HEIGHT
1	3.480	29.4789	1766.0
2	7.200	14.2553	814.0
3	10.280	9.9911	1159.0
4	14.500	7.0928	725.0
5	15.520	6.6292	129.0
6	20.700	4.9822	416.0
7	21.840	4.7250	345.0
8	24.300	4.2528	408.0
9	28.180	3.6768	193.0
10	29.260	3.5439	529.0
11	31.060	3.3431	1662.0
12	32.020	3.2454	246.0
13	32.560	3.1930	275.0
14	34.280	3.0372	139.0

MUSCOVITE  
+ CHLORITE  
+ QUARTZ  
+ FELDSPAR  
+ CALCITE  
+ LITTLE TALC

NO SMECTITE CLAY  
CANNOT TELL IF KAOLINITE PR  
— PROBABLY NOT.

965-57 (clay fraction)

$10^4 \cdot 2_{20}$



965-57-

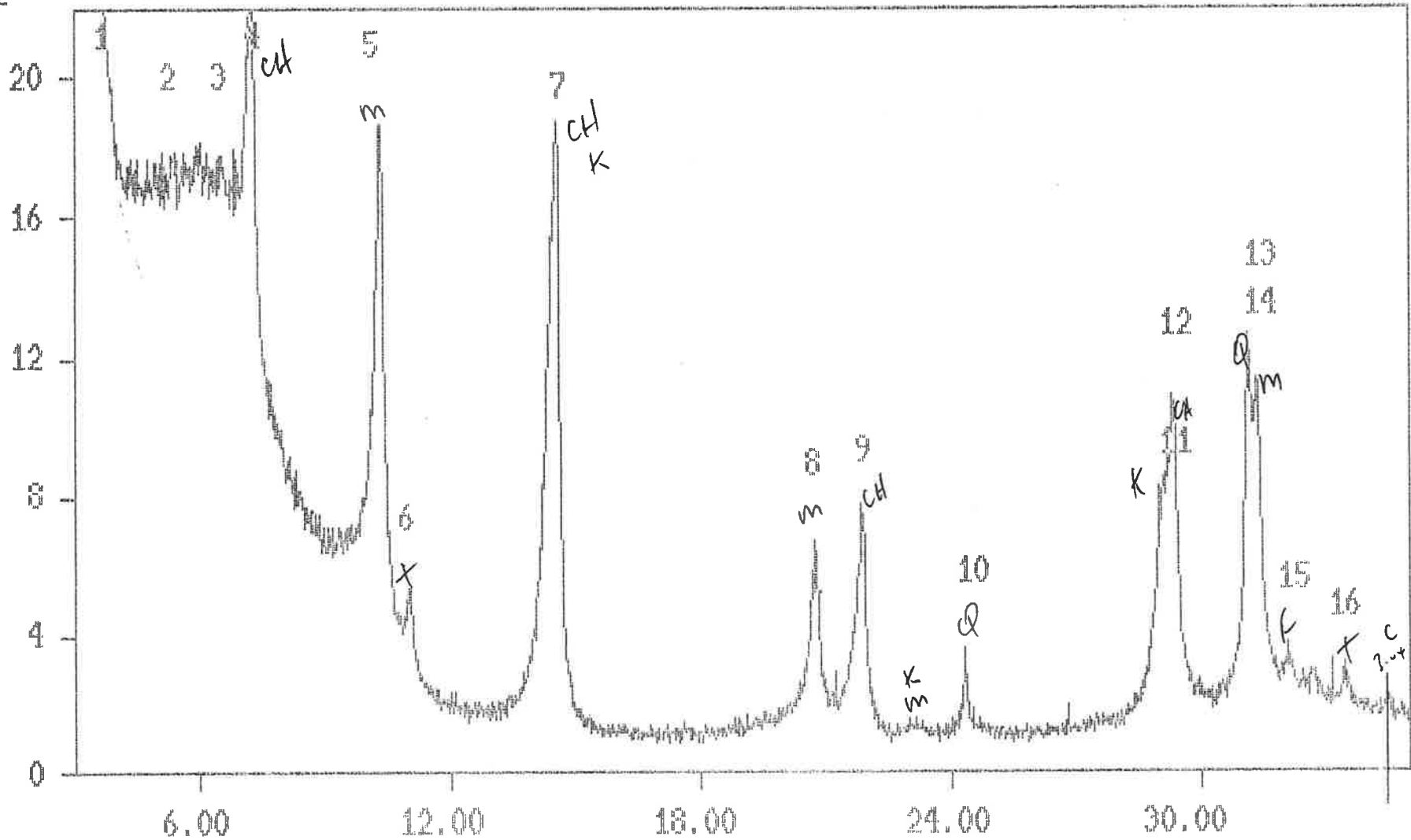
3  
35  
Co  
1.7902  
10-29-1992

SDH = 19 SENS = 1.0

#	2THETA	DSPACE	WEIGHT
1	3.260	31.4677	2990.0
2	4.540	22.5986	1654.0
3	6.480	15.8373	1452.0
4	6.820	15.0486	1392.0
5	7.220	14.2159	1475.0
6	10.320	9.9525	879.0
7	14.440	7.1221	733.0
8	20.760	4.9679	260.0
9	24.320	4.2494	216.0
10	29.060	3.5677	481.0
11	31.100	3.3389	456.0
12	32.080	3.2395	276.0

MUSCOVITE  
+ KAOLINITE  
+ CHLORITE  
+ QUARTZ  
+ FELDSPAR?  
SMELTITE CLAY?

10<sup>2</sup> 965-58 (clay fraction)



965 58c

3  
35  
Co  
1.7902  
10-29-1992

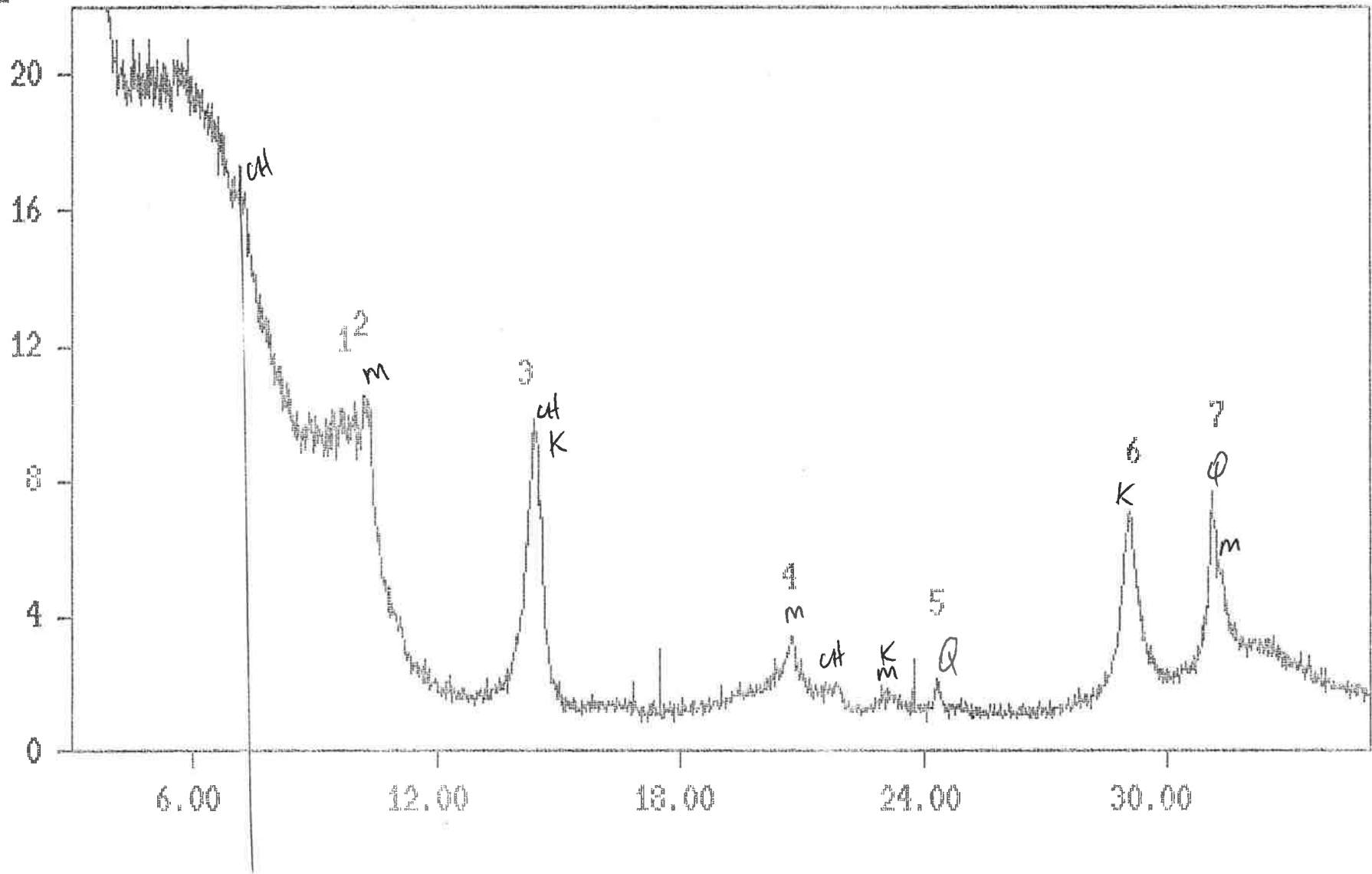
SCH = 19 SENS = 1.0

M	2THETA	DSPACE	HEIGHT
1	3.500	29.3105	2725.0
2	5.360	19.1433	1779.0
3	6.520	15.7402	1775.0
4	7.260	14.1377	2303.0
5	10.340	9.9333	1868.0
6	11.020	9.3221	538.0
7	14.520	7.0831	1874.0
8	20.740	4.9727	668.0
9	21.860	4.7208	777.0
10	24.320	4.2494	357.0
11	29.020	3.5726	823.0
12	29.320	3.5368	1092.0
13	31.120	3.3368	1260.0
14	31.340	3.3140	1135.0
15	32.060	3.2415	379.0
16	33.440	3.1113	319.0

CHLORITE  
+ KAOLINITE  
+ MUSCOVITE  
+ QUARTZ  
+ TALC  
+ FELDSPAR  
+ CALCITE

SMELTITE UAN

10<sup>2</sup> 965-59 (clay fraction)





965, 59c

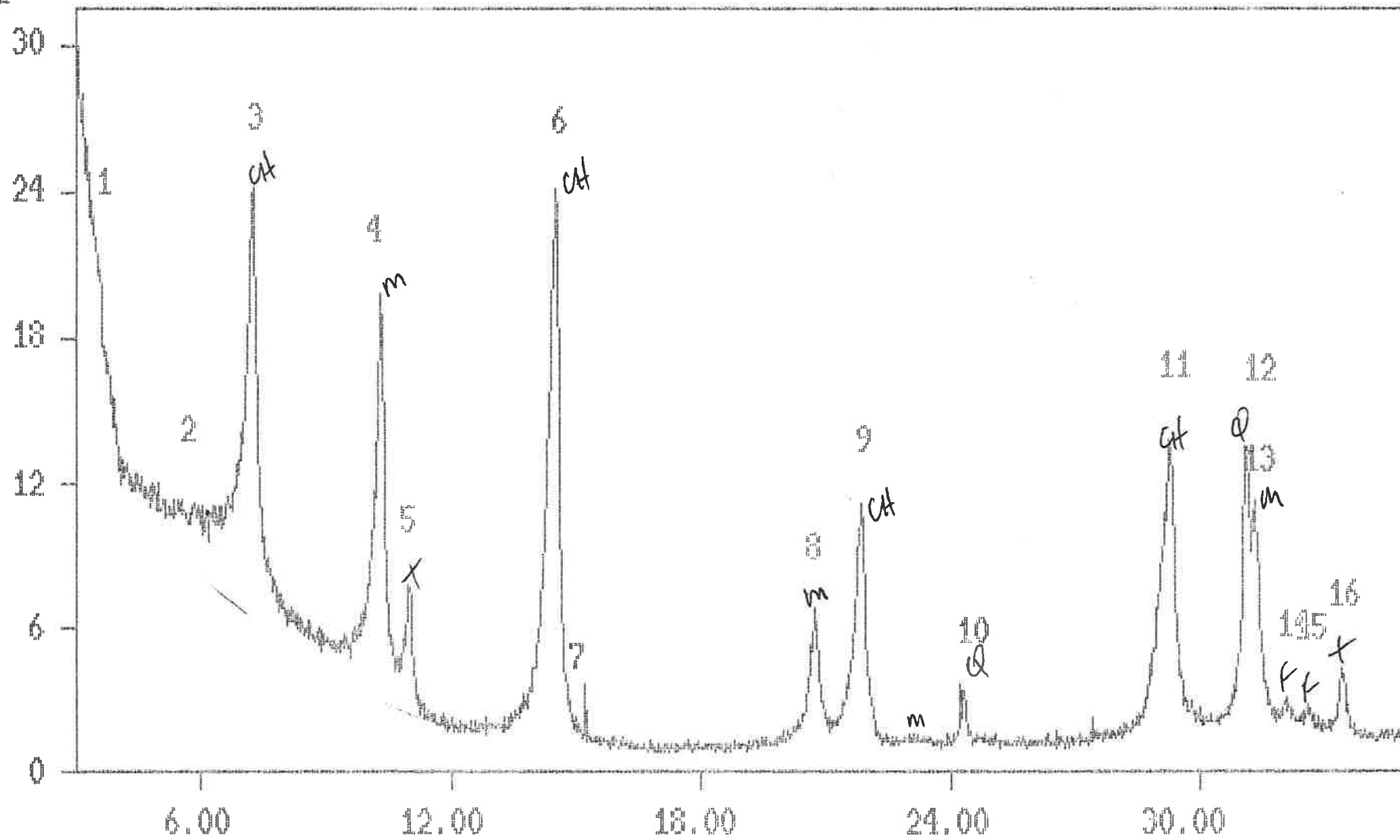
3  
35  
Cd  
1.7902  
10-29-1992

SCN = 19 SENS = 2.0

M	2THETA	DSPACE	HEIGHT
1	9.960	10.3113	1015.0
2	10.320	9.9525	1051.0
3	14.420	7.1319	981.0
4	20.700	4.9822	344.0
5	24.320	4.2494	216.0
6	29.040	3.5701	714.0
7	31.120	3.3368	770.0

CHLORITE  
+ KAOLINITE?  
+ MUSCOVITE  
+ QUARTZ  
SMECTITE CLAY

10<sup>2</sup> 965-60 (clay fraction)



965-60c

S  
38  
Co  
1,7902  
10-29-1992

SCH = 19 SENS = 1.0

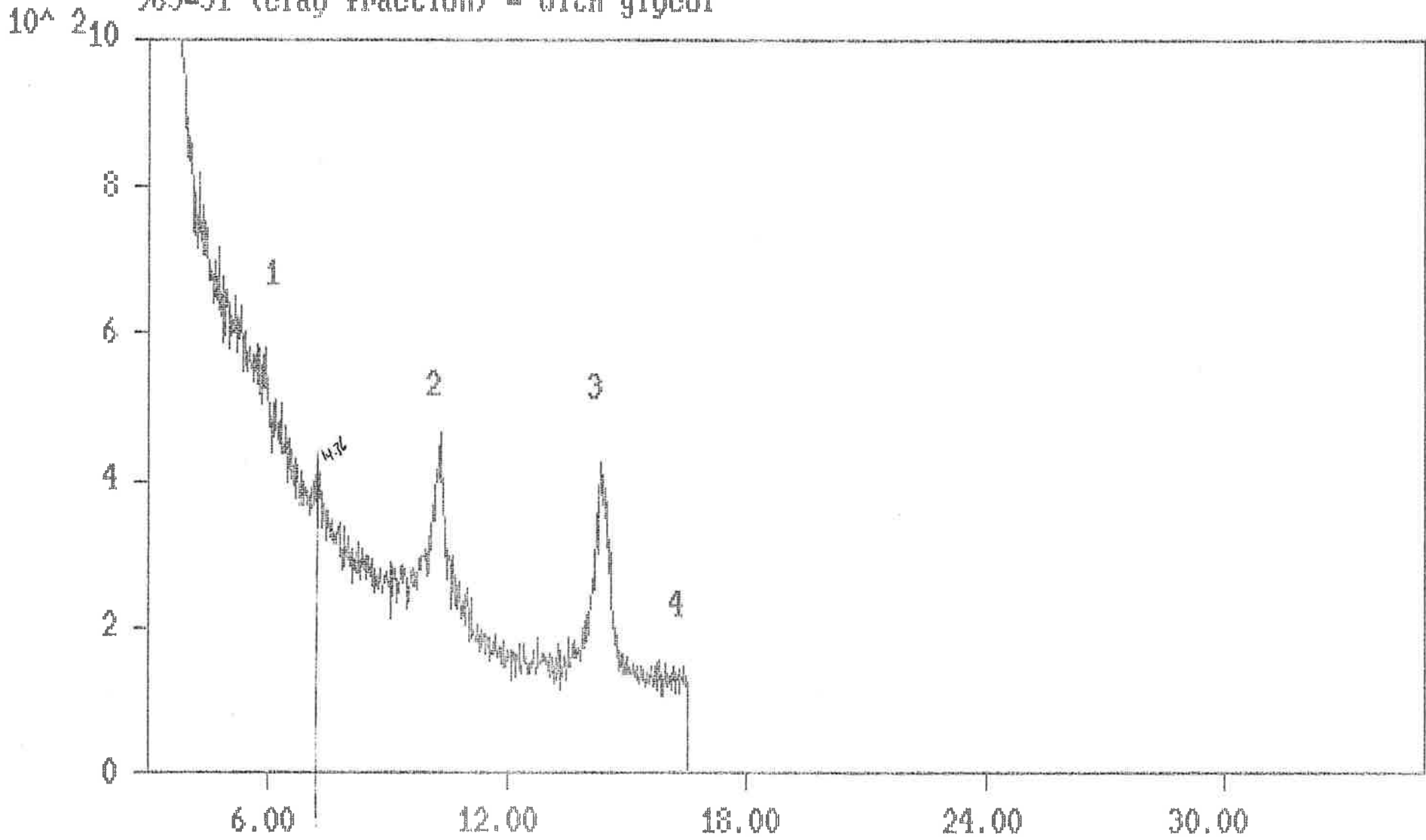
N	2THETA	DSPACE	HEIGHT
1	3.520	29.1440	2193.0
2	5.860	17.5112	1121.0
3	7.240	14.1767	2422.0
4	10.300	9.9718	1984.0
5	10.980	9.3559	788.0
6	14.500	7.0928	2416.0
7	15.200	6.7679	365.0
8	20.720	4.9774	687.0
9	21.820	4.7293	1104.0
10	24.280	4.2563	364.0
11	29.260	3.5439	1387.0
12	31.080	3.3410	1362.0
13	31.340	3.3140	1126.0
14	32.020	3.2454	310.0
15	32.600	3.1892	273.0
16	33.400	3.1149	439.0

CLORITE  
+ MICA  
+ QUARTZ  
+ TALC  
+ FELDSPAR  
NO KAOLINITE?  
SMECTITE CLAY

**X-RAY DIFFRACTION ANALYSIS: CLAY FRACTION OF SOIL SAMPLES WITH  
ETHYLENE GLYCOL, MAJOR ALLUVIAL FANS, WYACCA-EMEROO REGION**



965-51 (clay fraction) - with glycol



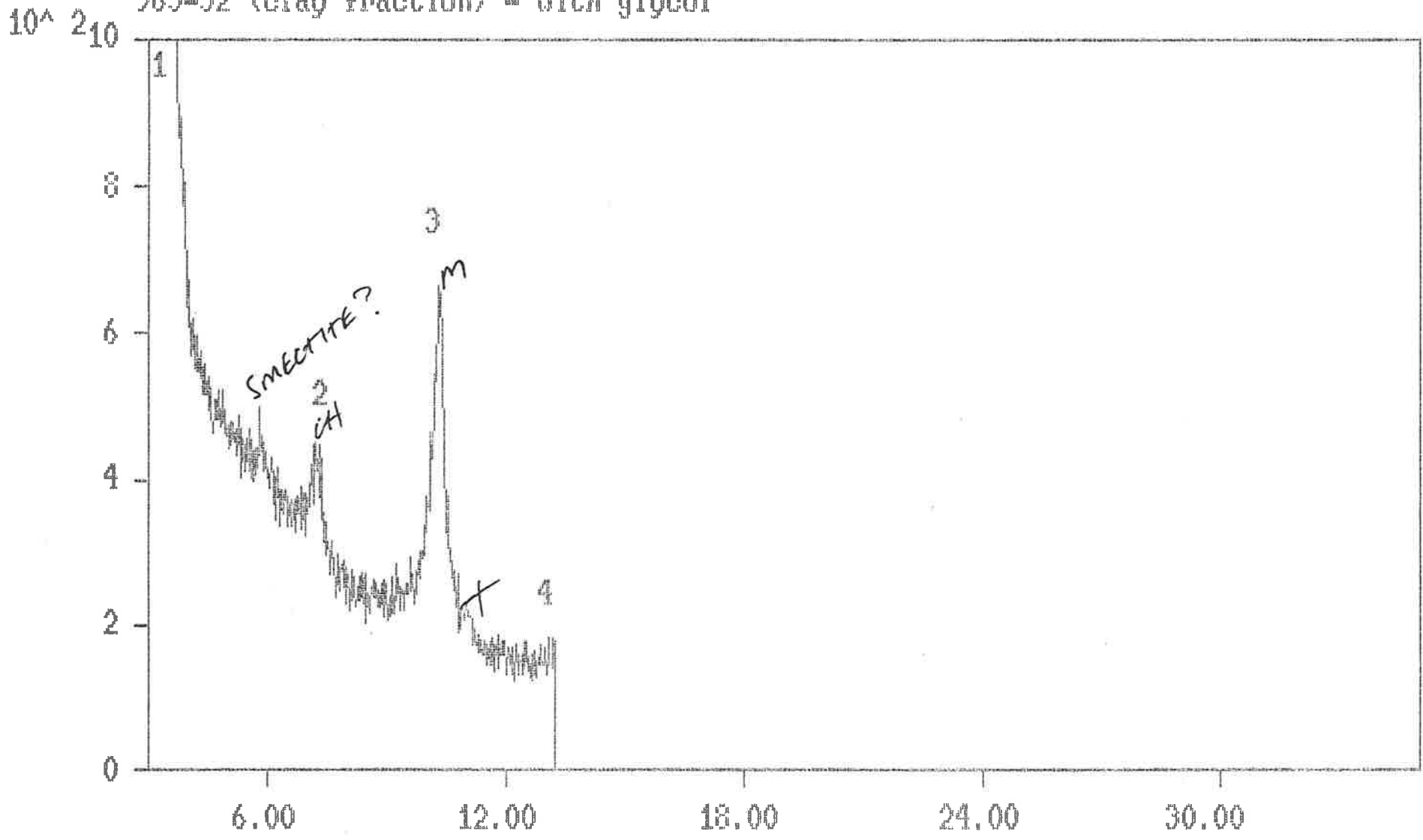
965-51 + e/g

3  
35  
Do  
1.7902  
10-29-1992

GCH = 19 SENS = 1.0

M	ZTHETA	DSPACE	HEIGHT
1	5.940	17.2756	578.0
2	10.300	9.9718	435.0
3	14.360	7.1616	424.0
4	16.380	6.2833	142.0

965-52 (clay fraction) - with glycol





965.52 + e/f

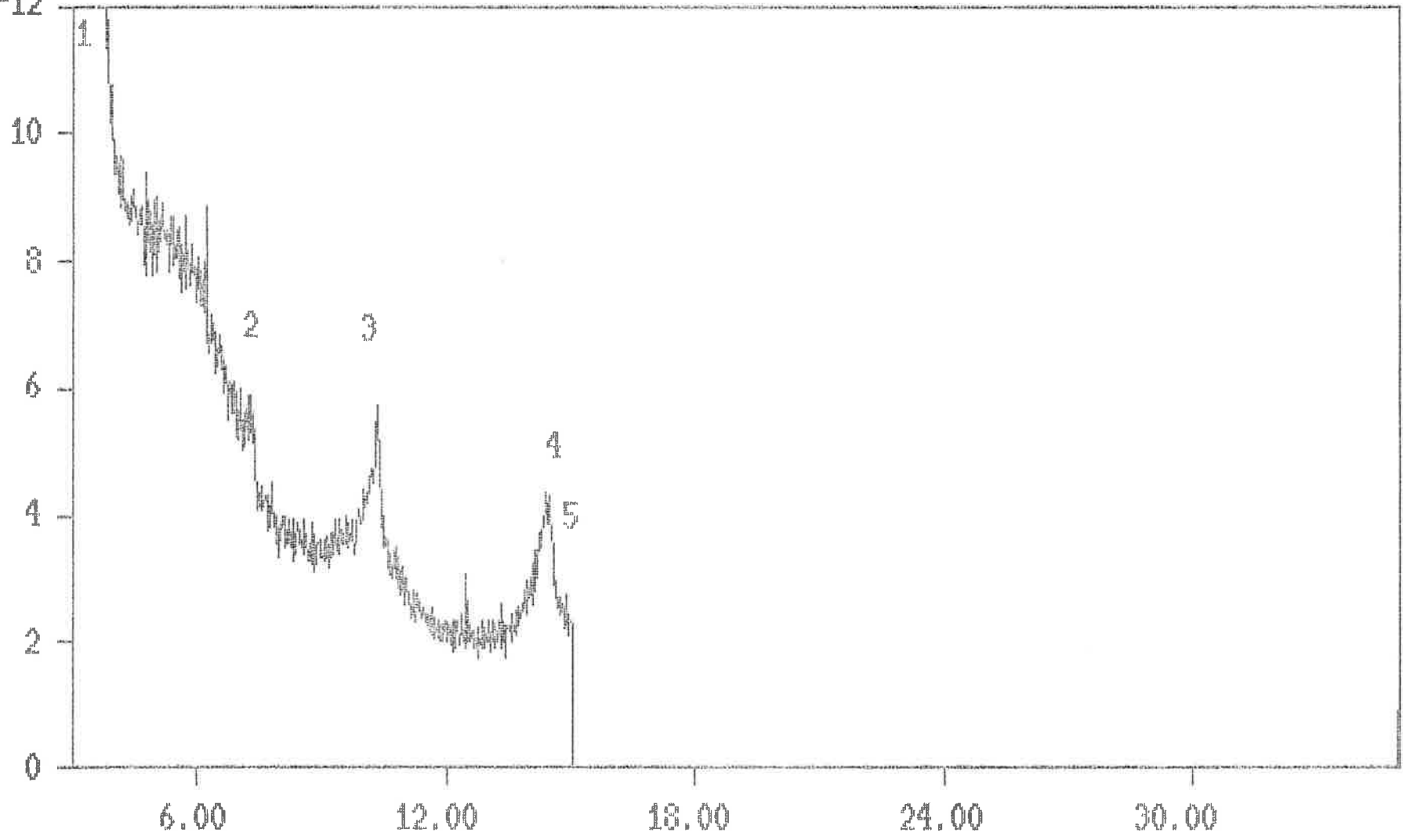
3  
35  
Ca  
1.7902  
10-29-1992

SCH = 15 SENS = 2.0

M	2THETA	DSPACE	HEIGHT
1	3.480	29.4789	1481.0
2	7.300	14.0603	445.0
3	10.340	9.9333	662.0
4	13.160	7.8113	183.0

965-53 (clay fraction) - with glycol

$10^4 \cdot 2_{12}$



755 + 533 = 1288

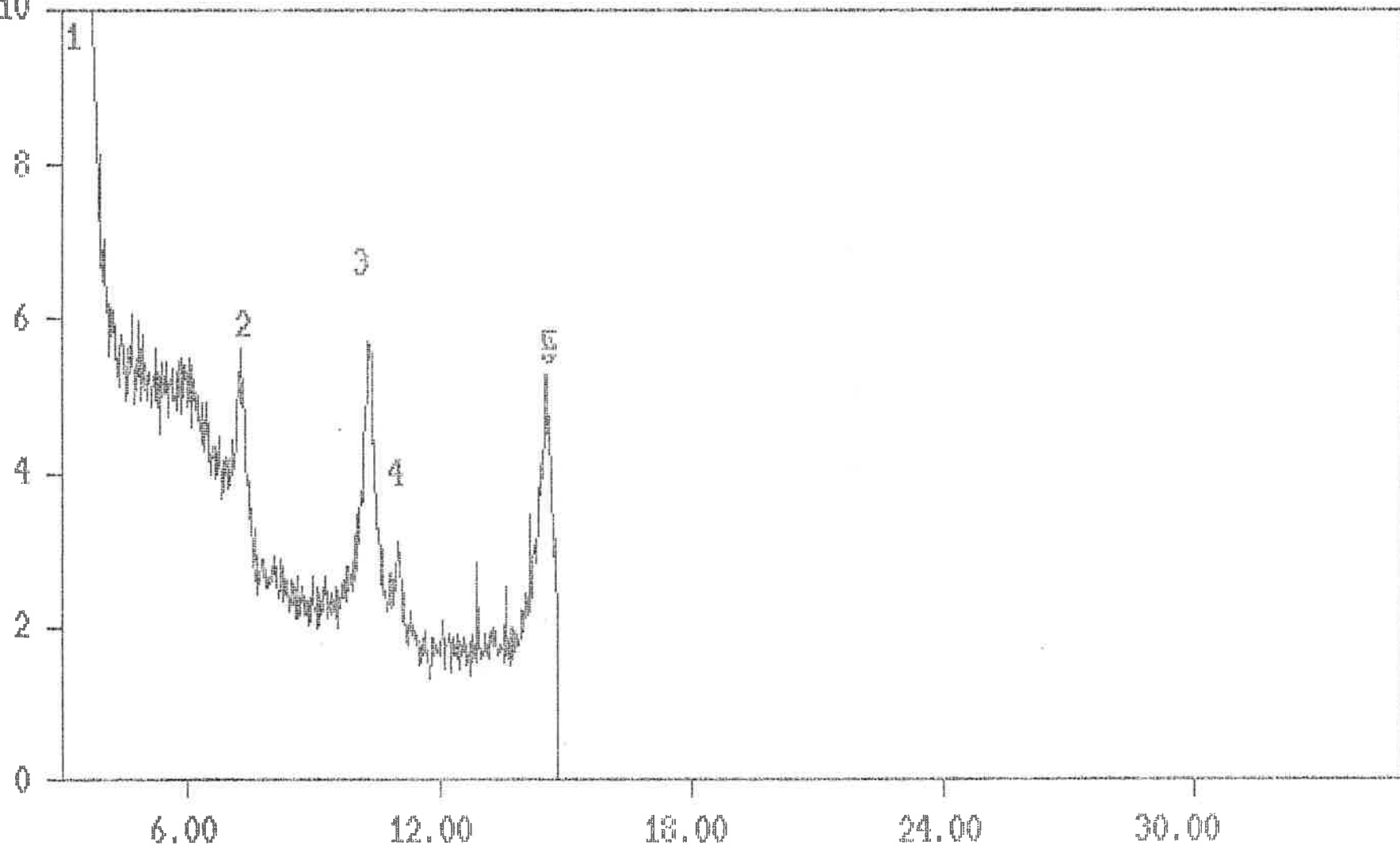
3  
35  
Co  
1,7902  
10-29-1992

SDH = 19. GENS = 1.0

N	2THETA	OSPACE	HEIGHT
1	3.480	29.4789	1877.0
2	7.280	14.0989	890.0
3	10.340	9.9333	574.0
4	14.460	7.1123	434.0
5	14.940	6.8850	277.0

965-54 (xclay fraction) - with glycol

$10^4 \cdot 2_{10}$



765.54 + c/g

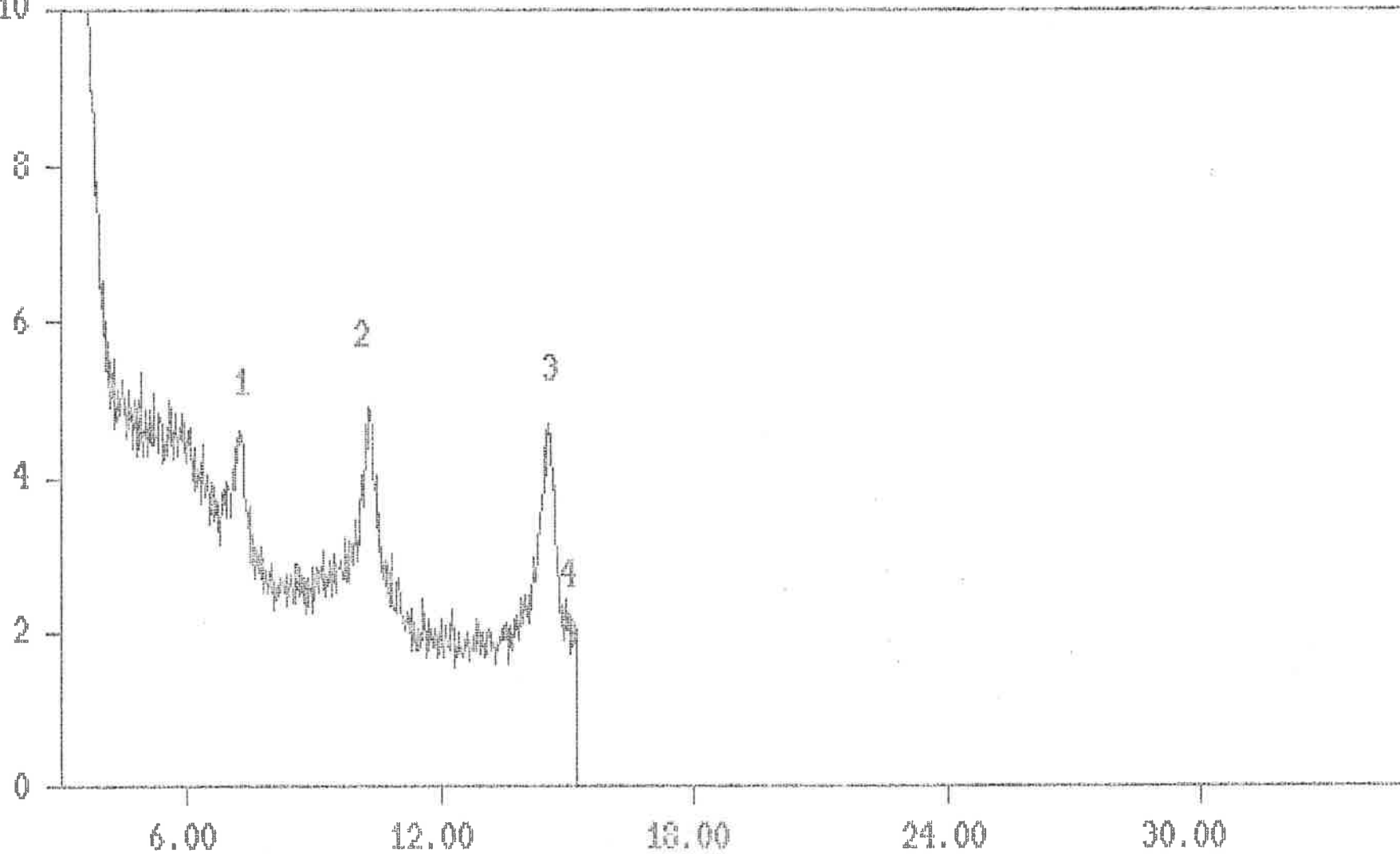
M  
38  
C8  
1.7902  
10-29-1992

BOH = 19 SENS = 1.0

M	2THETA	DSPACE	HEIGHT
1	3.480	29.4789	1468.0
2	7.280	14.0989	561.0
3	10.340	9.9333	569.0
4	11.020	9.3221	308.0
5	14.520	7.0631	525.0
6	14.640	7.0258	474.0

965-55 (clay fraction) - with glycol

$10^4 \cdot 2_{10}$



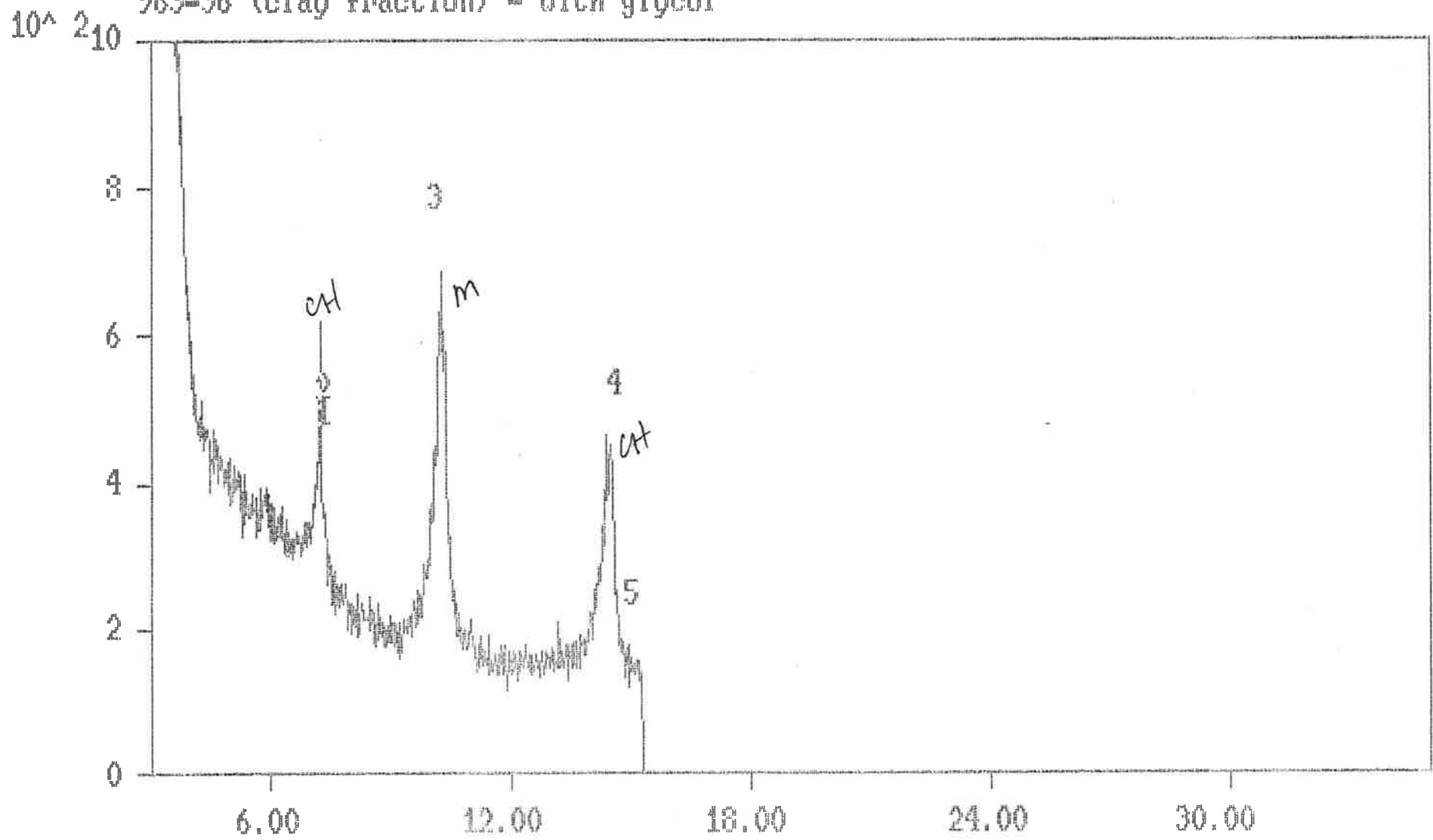
905.55 + e/g

3  
35  
00  
1.7902  
10-29-1992

SCH = 19 SENS = 1.0

N	2THETA	DSPACE	HEIGHT
1	7.240	14.1767	489.0
2	10.340	9.9333	491.0
3	14.580	7.0541	489.0
4	18.100	6.8125	219.0

965-56 (clay fraction) - with glycol





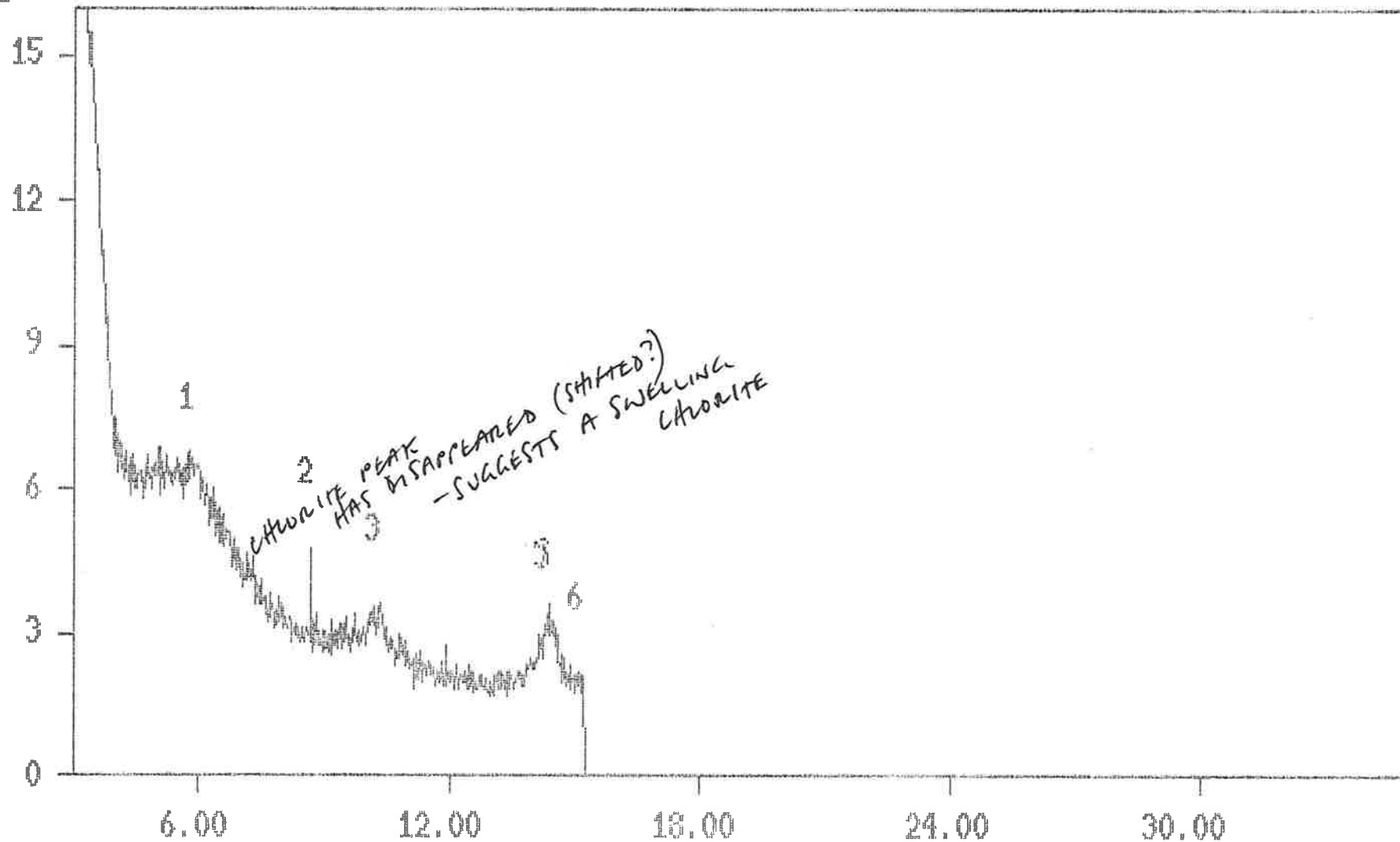
965.56 + 2/9

3  
35  
Ca  
1.7902  
10-29-1992

SCH = 19 SENS = 1.0

M	2THETA	DSPACE	HEIGHT
1	7.180	14.2950	458.0
2	7.240	14.1767	621.0
3	10.300	9.9718	683.0
4	14.460	7.1123	462.0
5	15.180	6.7768	156.0

10<sup>2</sup> 965-57 (clay fraction)-with glycol



965.57 + 9/3

3  
35

Co

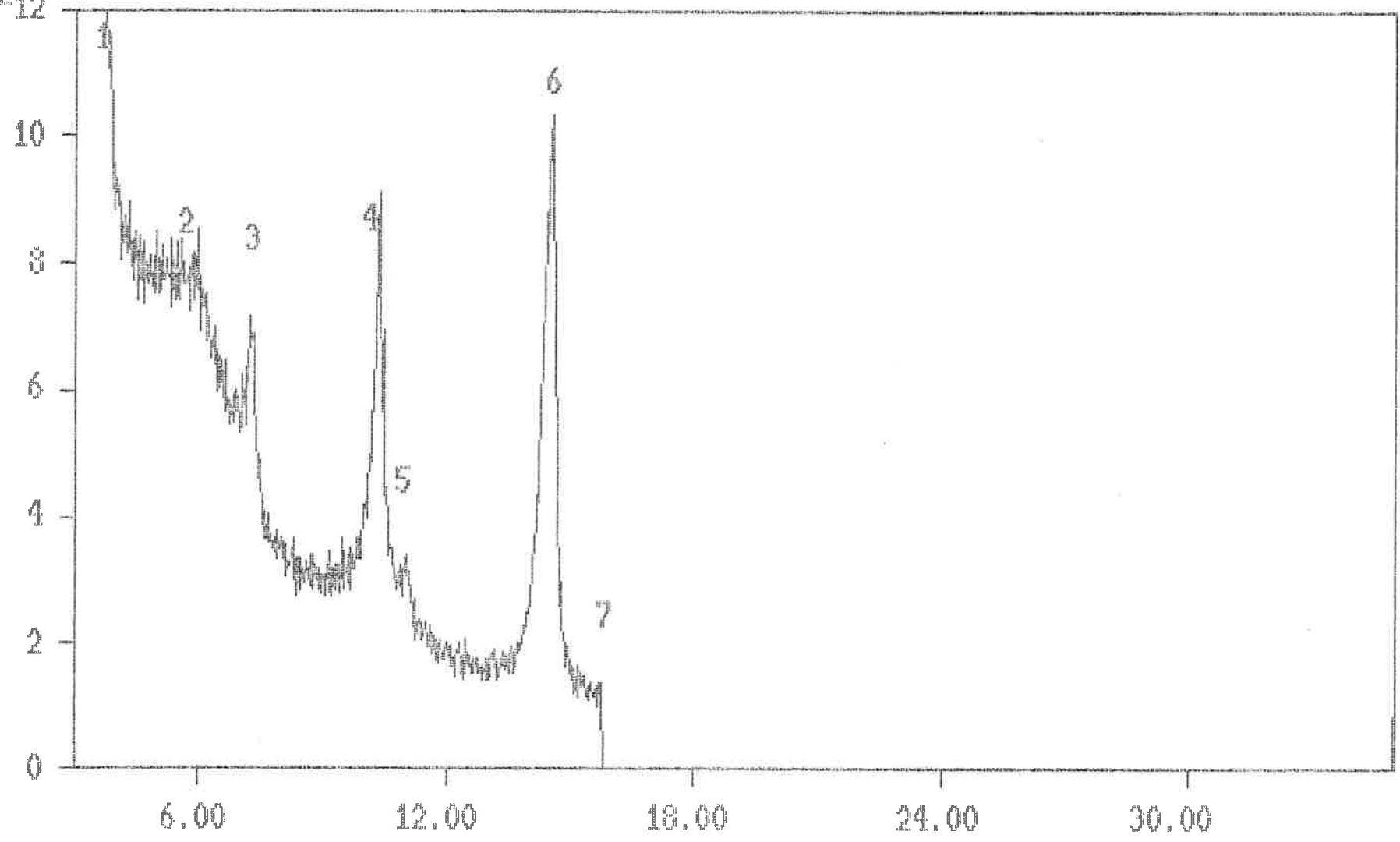
1.7902  
10-29-1992

SCN = 25    SENS = 1.0

M	2THETA	SPACE	HEIGHT
1	5.880	17.4517	679.0
2	8.680	<del>11.8282</del>	473.0
3	10.220	10.0496	355.0
4	14.340	7.1715	338.0
5	14.420	7.1319	339.0
6	15.080	6.8215	215.0

965-58 (clay fraction) - with glycol

$10^4 \cdot 2_{12}$



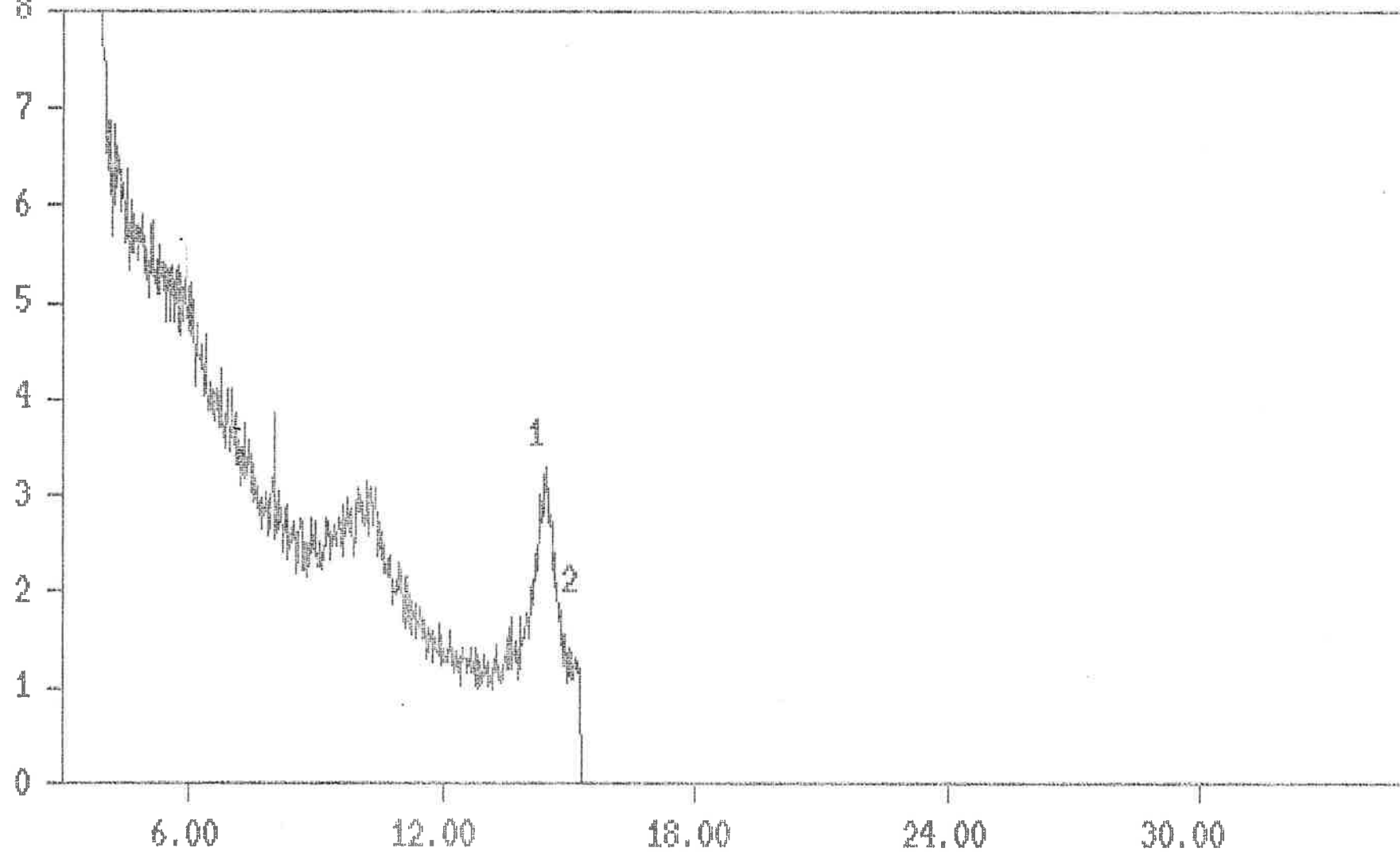
965-58 + c/s

3  
35  
00  
1.7902  
10-29-1992

SCH = 19    BENG = 1.0

M	2THETA	DSPACE	HEIGHT
1	3.780	27.1401	1369.0
2	5.920	17.3339	819.0
3	7.280	14.0989	718.0
4	10.360	9.9142	510.0
5	11.060	9.2885	341.0
6	14.560	7.0637	1032.0
7	15.700	6.5537	136.0

10<sup>2</sup> 965-59 (clay fraction) - with glycol



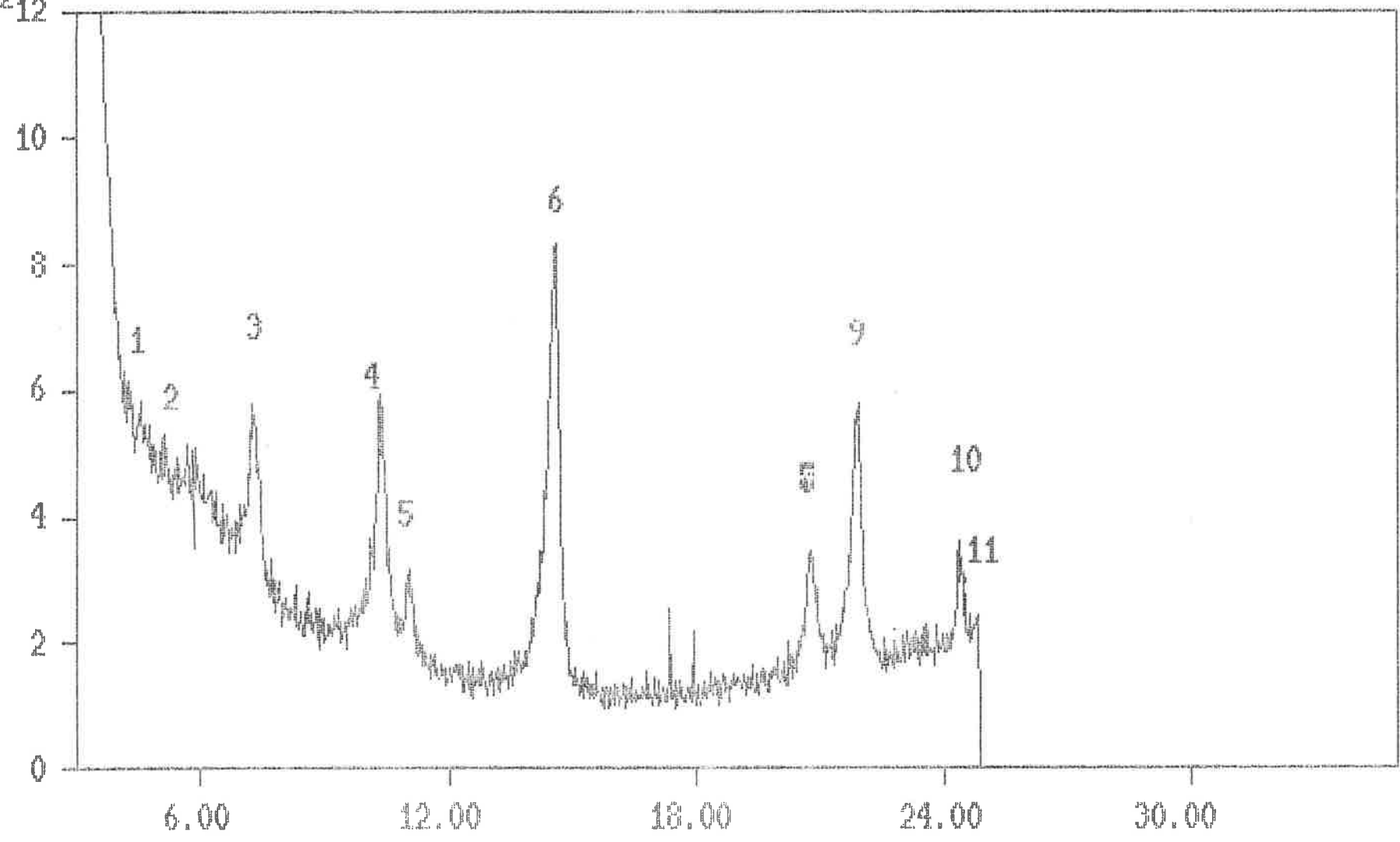
905-59-413

35  
1.7902  
10-29-1992

SCH = 19 SENS = 1.0

N	2THETA	SPACE	HEIGHT
1	14.420	7.1319	325.0
2	15.160	6.7857	130.0

10<sup>2</sup> 965-60 (clay fraction) - with glycol





965.60 + c/s

W  
W6  
Co  
1.7902  
10-29-1992

SCN = 19 SENS = 1.0

N	2THETA	DSPACE	HEIGHT
1	4.600	22.3040	582.0
2	5.160	19.8848	532.0
3	7.300	14.0603	578.0
4	10.360	9.9142	596.0
5	11.040	9.3052	618.0
6	14.560	7.0637	834.0
7	20.720	4.9774	341.0
8	20.780	4.9632	347.0
9	21.900	4.7122	579.0
10	24.380	4.2391	363.0
11	24.740	4.1783	237.0

## BIBLIOGRAPHY

- AKAGI, Y. 1972 Pediment morphology in Japan. Fukuoka University of Education, Bulletin 21: 1-63.
- ALLEY, N. F. & LEMON, N. M. 1988 Evidence of earliest Cretaceous (Neocomian) marine influence, northern Flinders Ranges. Geological Survey of South Australia, Quarterly Geological Notes 106: 2-7.
- AMBROSE, G. J. & FLINT, R. B. 1981 A regressive Miocene lake system and silicified strandlines in northern South Australia: implication for regional stratigraphy and silcrete genesis. Geological Society of Australia, Journal 28: 81-94.
- ANDERSON, C. G. 1979 Magnetic and gravity interpretation on the Stuart Shelf. South Australian Department of Mines & Energy, Report Book 79/149 (unpublished).
- ANONYMOUS 1974 Dampier Mining Co. Ltd. Exploration Licence 112 - Parachilna, South Australia. South Australian Department of Mines & Energy, Envelope 2386 (unpublished).
- ANONYMOUS 1982 B.H.P. Pty. Ltd. Exploration Licence 726 - Commodore, South Australia. South Australian Department of Mines & Energy, Envelope 3969 (unpublished).
- BALCHIN, W. G. V. & PYE, N. 1955 Piedmont profiles in the arid cycle. Geologists Association, Proceedings 66(3): 167-181.
- BEATY, C. B. 1963 Origin of alluvial fans, White Mountains, California and Nevada. Association of American Geographers, Annals 53(4): 516-535.
- BEATY, C. B. 1970 Age and estimated rate of accumulation of an alluvial fan, White Mountains, California, U.S.A. American Journal of Science 268: 50-77.
- BEATY, C. B. 1974 Debris flows, alluvial fans, and a revitalized catastrophism. Zeitschrift für Geomorphologie 21: 39-51.
- BEATY, C. B. 1990 Anatomy of a White Mountains debris-flow - the making of an alluvial fan. Chapter 4, pp.69-89 in RACHOCKI, A. H. & CHURCH, M. (editors), Alluvial Fans. A Field Approach. John Wiley & Sons, Chichester, 391p.
- BERKEY, C. P. & MORRIS, F. K. 1927 Geology of Mongolia, pp.323-351 in Natural History of Central Asia II, 475p.
- BINKS, P. J. 1972 Late Cainozoic uplift of the Ediacara Range, South Australia. Australian Institute of Mining and Metallurgy, Proceedings 243: 47-55.
- BLACKWELDER, E. 1928 Mudflow as a geologic agent in semiarid mountains. Geological Society of America, Bulletin 39: 465-484.
- BLACKWELDER, E. 1931 Desert plains. Journal of Geology 39(2): 133-140.
- BLISSENBACH, E. 1952 Relation of surface angle distribution to particle size distribution on alluvial fans. Journal of Sedimentary Petrology 22(1): 25-28.
- BLISSENBACH, E. 1954 Geology of alluvial fans in semiarid regions. Geological Society of America, Bulletin 65: 175-190.

- BLUCK, B. J. 1964 Sedimentation on an alluvial fan in southern Nevada. *Journal of Sedimentary Petrology* 34: 395-400
- BOWMAN, D. 1978 Determination of intersection points within a telescopic alluvial fan complex. *Earth Surface Processes* 3: 265-276.
- BRADLEY, W. H. 1940 Pediments and pedestals in miniature. *Journal of Geomorphology* 3(3): 244-255.
- BRYAN, K. 1922 Erosion and sedimentation in the Papago Country, Arizona with a sketch of the Geology. United States Geological Survey, Bulletin 730-B, pp.19-90.
- BRYAN, K. 1925 The Papago country. United States Geological Survey, Water-Supply Paper 499, 436p.
- BRYAN, K. 1936a The formation of pediments. 16th International Geological Congress (1933), Report 2: 765-775.
- BRYAN, K. 1936b Processes of formation of pediments at Granite Gap, New Mexico. *Zeitschrift für Geomorphologie* 9: 125-135.
- BRYAN, K. & McCANN, F. T. 1936 Successive pediments and terraces of the Upper Rio Puerco in New Mexico. *Journal of Geology* 44(2): 145-172.
- BULL, W. B. 1962a Relations of alluvial-fan size and slope to drainage-basin size and lithology in western Fresno County, California. Article 19 in United States Geological Survey, Professional Paper 450-B: 51-53.
- BULL, W. B. 1962b Relation of textural (CM) patterns to depositional environment of alluvial-fan deposits. *Journal of Sedimentary Petrology* 32(2): 211-216.
- BULL, W. B. 1964a Alluvial fans and near surface subsidence in Western Fresno County, California. United States Geological Survey, Professional Paper 437A, 1-71.
- BULL, W. B. 1964b Geomorphology of segmented alluvial fans in western Fresno County, California. United States Geological Survey, Professional Paper, 352-E: 89-129.
- BULL, W. B. 1968 Alluvial fans. *Journal of Geological Education*, 16: 101-106.
- BULL, W. B. 1972 Prehistoric near-surface subsidence cracks in Western Fresno County, California. United States Geological Survey, Professional Paper 437-C, 86p.
- BULL, W. B. 1977 The alluvial-fan environment. *Progress in Physical Geography* 1(2): 222-270.
- BULL, W. B., McCULLOUGH, E. J., KRESAN, P. L., WOODWARD, J. & CHASE, C. G. 1990 Quaternary geology and geologic hazards near Cañada del Oro, Tucson, Arizona, pp.1-8 in GEHRELS, G. E. & SPENCER, J. E. (editors), *Geologic Excursions through the Sonoran Desert Region, Arizona and Sonora. Field-Trip Guidebook, 86th Annual Meeting, Cordilleran Section, Geological Society of America, Tucson, Arizona.*
- BURNE, R. V. 1982 Relative fall of Holocene sea level and coastal progradation, northeastern Spencer Gulf, South Australia. *BMR Journal of Australian Geology and Geophysics* 7: 35-45.
- BUREAU OF METEOROLOGY 1991 *Manual of Meteorology. Part I, General Meteorology.* Australian Government Publishing Service, Canberra, 149p.

- BUWALDA, J. P. 1951 Transportation of coarse material on alluvial fans. (Abstract) Geological Society of America, Bulletin 62: 1497.
- CALLEN, R. A. 1973 Lake Frome area, regional geology and Tertiary stratigraphy. South Australian Department of Mines, Report Book 73/263 (unpublished).
- CALLEN, R. A. 1983 Late Tertiary "grey billy" and the age and origin of surficial silicifications (silcrete) in South Australia. Geological Society of Australia, Journal 30(4): 393-410.
- CALLEN, R. A. & REID, P.W. (Compilers) 1994 Geology of the Flinders Ranges National Park. South Australia. Geological Survey. Special Map, 1:75,000.
- CALLEN, R. A. & TEDFORD, R. H. 1976 New Late Cainozoic rock units and depositional environments, Lake Frome area, South Australia. Royal Society of South Australia, Transactions 100(3): 125-167.
- CAMPANA, B. P. 1958, Flinders Ranges. Chapter II, pp. 28-45 in GLAESSNER, M. F. & PARKIN, L. W. (editors), The Geology of South Australia. Melbourne University Press for Geological Society of Australia, Victoria, 163p.
- CARSON, M. A. & KIRKBY, M. J. 1972 Hillslope Form and Process. Cambridge University Press, London, 475p.
- CHAPPELL, J. & SHACKLETON, N. J. 1986 Oxygen isotopes and sea level. Nature 324: 137-140.
- CLAYTON, R. W. 1956 Linear depressions (Bergfussniederungen) in savannah landscapes. Geographical Studies 3: 102-126.
- CLEARY, J. R. & SIMPSON, D. W. 1971 Seismotectonics of the Australian continent. Nature 230: 239-241.
- COATS, R. P. (compiler) 1973 COPLEY, South Australia. Sheet SH 54-9 International Index, 1:250 000 Geological Series. Geological Survey of South Australia, Explanatory Notes, 38p.
- COATS, R. P. & BLISSETT, A. H. 1971 Regional and economic geology of the Mount Painter Province. Geological Survey of South Australia, Bulletin 43, 426p.
- COCKSHELL, C. D. 1983 Edeowie No. 1. Well Completion Report. Geological Survey. South Australian Department of Mines & Energy, Report Book 83/56 (unpublished).
- COOKE, R. U. 1970 Morphometric analysis of pediments and associated landforms in the western Mojave Desert, California. American Journal of Science 269: 26-38.
- COOKE, R. U. & MASON, P. F. 1973 Desert knolls, pediment and associated landforms in the Mojave Desert, California. Revue de Géomorphologie Dynamique 22: 49-60.
- COOKE, R. U. & REEVES, R. W. 1972 Relations between debris size and the slope of mountain fronts and pediments in the Mojave Desert, California. Zeitschrift für Geomorphologie N.F. 16(1): 76-82.
- COOKE, R. U. & WARREN, A. 1973 Geomorphology in Deserts. B. T. Batsford Ltd., London, 374p.
- COOKE, R. U., WARREN, A. & GOUDIE, A. 1993 Desert Geomorphology. UCL Press, London, 526p.
- CORBEL, J. 1963 Pédiments d'Arizona (Pediments of Arizona). Centre de Documentation cartographique et géographiques, Mémoires et Documents 9: 31-95.

- COXHEAD, C. 1982 Brown coal potential of the Wilkatana area, South Australia. South Australian Department of Mines & Energy, Envelope 3769, Report (unpublished).
- CRAWFORD, A. R. 1963 Quaternary sedimentary breccias and emerged offshore bars near Point Lowly. Geological Survey of South Australia, Quarterly Geological Notes 5: 1-2.
- DALGARNO, C. R. (Compiler) 1982 ANDAMOOKA map sheet. Geological Atlas 1:250 000 Series, Sheet SH 53-12. Geological Survey of South Australia.
- DALGARNO, C. R. & JOHNSON, J. E. 1966 PARACHILNA map sheet. Geological Atlas 1:250 000 Series, Sheet SH 54-13. Geological Survey of South Australia.
- DALGARNO, C. R. & JOHNSON, J. E. 1968 Diapiric structures and Late Precambrian-Early Cambrian sedimentation in Flinders Ranges, South Australia, pp.301-314 in BRAUNSTEIN, J. & O'BRIEN, G. D. (eds.), Diapirism and Diapirs: a Symposium. American Association of Petroleum Geologists, Memoir 8, Oklahoma, USA, 444p.
- DALGARNO, C. R., JOHNSON, J. E., FORBES, B. G. & THOMSON, B. P. 1968 PORT AUGUSTA map sheet. Geological Atlas 1:250 000 Series, Sheet SI 53-4. Geological Survey of South Australia.
- DAVIS, W. M. 1905 The geographical cycle in an arid climate. Journal of Geology 13: 381-407.
- DAVIS, W. M. 1930 Rock floors in arid and in humid climates. Parts I & II. Journal of Geology 38: 1-27, 136-158.
- DAVIS, W. M. 1933 Granitic domes of the Mojave Desert, California. San Diego Society of Natural History, Transactions 7: 211-258.
- DAVIS, W. M. 1938 Sheetfloods and streamfloods. Geological Society of America, Bulletin 49: 1337-1416.
- DeCELLES, P. G., GRAY, M. B., RIDGWAY, K. D., COLE, R. B., PIVNIK, D. A., PEQUERA, N. & SRIVASTAVA, P. 1991 Controls on synorogenic alluvial-fan architecture, Beartooth Conglomerate (Palaeocene), Wyoming and Montana. Sedimentology 38: 567-590.
- DENHAM, D., SMALL, G. R., CLEARY, J. R., GREGSON, P. J., SUTTON, D. J. & UNDERWOOD, R. 1975 Australian earthquakes (1897 - 1972). Search 6(1-2): 34-37.
- DENNY, C. S. 1965 Alluvial fans in the Death Valley region, California and Nevada. United States Geological Survey, Professional Paper 466, 62p.
- DENNY, C. S. 1967 Fans and pediments. American Journal of Science 265: 81-105.
- DOEGLAS, D. J. 1962 The structure of sedimentary deposits of braided rivers. Sedimentology 1: 167-190.
- DOEHRING, D. O. 1970 Discrimination of pediments and alluvial fans from topographic maps. Geological Society of America, Bulletin 81: 3109-3115
- DOUTCH, H. F., INGRAM, J. A., SMART, J. & GRIMES, K. G. 1970 Progress report on the geology of the southern Carpentaria Basin. Department of National Development, B. M. R. Geology & Geophysics, Record 1970/39, 48p.
- DOYLE, H. A., EVERINGHAM, I. B. & SUTTON, D. J. 1968 Seismicity of the Australian continent. Geological Society of Australia, Journal 15(2): 295-312.

- DRAPER, N. R. & SMITH, H. 1967 Applied regression analysis. John Wiley & Sons Inc., New York, 407p.
- DREW, F. 1873 Alluvial and lacustrine deposits and glacial records of the Upper Indus Basin. Geological Society of London, Quarterly Journal 29: 441-471.
- DREXEL, J. F. & PREISS, W. V. (editors) 1995 The geology of South Australia. Volume 2, The Phanerozoic. Geological Survey of South Australia, Bulletin 54, 346p.
- DREXEL, J. F., PREISS, W. V. & PARKER, A. J. (editors) 1993 The geology of South Australia. Volume I, The Precambrian. Geological Survey of South Australia, Bulletin 54, 242p.
- DRURY, S. A. 1987 Image Interpretation in Geology. Allen & Unwin, London, 243p.
- DUDLEY, P. H. 1936 Physiographic history of a portion of the Perris Block, southern California. Journal of Geology 44(3): 358-378.
- DUNHAM, M. N. E. 1992 The geomorphological nature and age of the linear escarpments of northeastern Eyre Peninsula. Honours Thesis, University of Adelaide, South Australia (unpublished), 43p.
- DURY, G. H. 1966 Pediment slope and particle size at Middle Pinnacle, near Broken Hill, New South Wales. Australian Geographical Studies IV(1): 1-17.
- DUTTON, C. E. 1880 Report on the geology of the high plateaus of Utah. United States Geographical and Geological Survey of the Rocky Mountain Region, Washington, 307p.
- DUTTON, C. E. 1882 The Physical Geology of the Grand Cañon District, pp. 47-166 in 1880-1881 United States Geological Survey, Second Annual Report. Government Printing Office, Washington, 588p.
- DUTTON, W. G. 1975 A description and explanation of a flight of river terraces on Hookina Creek in the Flinders Ranges, South Australia. Honours Thesis, University of Adelaide, South Australia (unpublished), 22p.
- ECKIS, R. 1928 Alluvial fans of the Cucamonga district, southern California. Journal of Geology 36: 224-247.
- FAIR, T. J. D. 1947 Slope form and development in the interior of Natal, South Africa. Geological Society of South Africa, Transactions 50: 105-119.
- FAIR, T. J. D. 1948 Slope form and development in the coastal hinterland of Natal. Geological Society of South Africa, Transactions 51: 33-47.
- FIELD, R. 1935 Stream carved slopes and plains in desert mountains. American Journal of Science (Fifth Series) 29: 313-321.
- FINLAYSON, B. 1981, Geophysical interpretation of data from southern Lake Torrens-Stuart Shelf. Geological Survey. South Australian Department of Mines and Energy, Envelope 3769, Report Book 81/50 (unpublished).
- FIRMAN, J. B. 1965 Late Cainozoic sedimentation in northern Spencer Gulf, South Australia. Royal Society of South Australia, Transactions 89: 125-131.
- FISHER, O. 1866 On the disintegration of a chalk cliff. Geological Magazine 3: 354-356.
- FORBES, B. G. 1966 The geology of the Marree 1:250 000 map area. Geological Survey of South Australia, Report of Investigations 28, 47p.

- FORBES, B. G. (compiler) 1972 PARACHILNA map sheet. Geological Atlas 1:250 000 Series, Sheet SH 54-13. Geological Survey of South Australia, Explanatory Notes, 24p.
- FRAKES, L. (Coordinator: Australian Cretaceous Palaeoenvironments Group) 1987 Australian Cretaceous shorelines, stage by stage. Palaeogeography, Palaeoclimatology, Palaeoecology, 59: 31-48.
- GALLOWAY, W. E. & HOBDDAY, D. K. 1983 Terrigenous Clastic Depositional Systems: applications to petroleum, coal, and uranium exploration. Springer-Verlag, New York, 423p.
- GEIKIE, A. 1886 Class-book of Geology. Macmillan, London, 516p.
- GERDES, R. A. 1982 The interpreted depths to magnetic basement map of South Australia. Geological Survey of South Australia, Quarterly Geological Notes 83, 15p.
- GILBERT, G. K. 1875 Report on the geology of portions of Nevada, Utah, California and Arizona (1871-72). Report upon Geographical and Geological Explorations and Surveys West of the One Hundredth Meridian; in charge of First Lieutenant G.M. Wheeler, Washington 3(1): 21-187.
- GILBERT, G. K. 1877 Report on the Geology of the Henry Mountains. United States of America Geographical and Geological Survey of the Rocky Mountain Region. Government Printing Office, Washington, 160p.
- GILBERT, G. K. 1882 Contributions to the History of Lake Bonneville, pp. 167-200, in 1880-1881 United States Geological Survey, Second Annual Report. Government Printing Office, Washington, 588p.
- GILBERT, G. K. 1890 Lake Bonneville. United States Geographical Survey, Monograph 1.
- GILLULY, J. 1937 Physiography of the Ajo region, Arizona. Geological Society of America, Bulletin 48: 323-347.
- GLAESSNER, M. F. & WADE, M. 1958 The St Vincent Basin. Chapter IX, pp.115-126 in GLAESSNER, M. F. & PARKIN, L. W. (editors), The Geology of South Australia. Melbourne University Press for Geological Society of Australia, Victoria, 163p.
- GLOCK, W. S. 1936 Desert cliff recession and lateral regional planation. Pan American Geology 66: 81-86.
- GOSTIN, V. A., HAILS, J. R. & POLACH, H. A. 1981 Quaternary sea levels in upper Spencer Gulf, South Australia. Search 12: 43-45.
- GOSTIN, V. A. & RUST, B. R. 1983 Sedimentary features of some Quaternary alluvial fan successions, South Australia, pp.37-55 in WILLIAMS, B. P. J. & MOORE, P. S. (editors), Fluvial Sedimentology Workshop. Australasian Sedimentologists Specialists Group, Adelaide, 440p.
- GREENHALGH, S. A. & DENHAM, D. 1986 The Beltana, South Australian earthquake of 29 December 1983 and aftershocks. Australian Journal of Earth Sciences 33: 401-411.
- GREGORY, K. J. & WALLING, D. E. 1973 Drainage Basin Form and Process. Edward Arnold Ltd., London, 456p.
- HADLEY, R. F. 1967 Pediments and pediment-forming processes. Journal of Geological Education 15(2): 83-89.

- HAILS, J. R., BELPERIO, A. P. & GOSTIN, V. A. 1983 Holocene sea levels of upper Spencer Gulf, South Australia. Chapter 3, pp.48-53 in HOPLEY, D. (editor), Australian Sea Levels in the Last 15 000 Years: A Review. Monograph Series, Occasional Paper No.3, Department of Geography, James Cook University of North Queensland, 104p.
- HAILS, J. R. & GOSTIN, V. A. 1978 Stranded shingle beach ridges, upper Spencer Gulf, South Australia: evidence for high wave energy dissipation during the Late Pleistocene. Royal Society of South Australia, Transactions 102(6): 169-173.
- HARVEY, A. M. 1987 Alluvial fan dissection: relationships between morphology and sedimentation, pp.87-103 in FROSTICK, L. & REID, I. (editors), Desert Sediments: Ancient and Modern. Geological Society Special Publication No.35, 401p.
- HARVEY, A. M. 1989 The occurrence and role of arid zone alluvial fans, pp.136-158 in THOMAS, D. S. G. (editor), Arid Zone Geomorphology. Belhaven Press, London, 372p.
- HARVEY, A. M. 1990 Factors influencing Quaternary alluvial fan development in southeast Spain. Chapter 13, pp. 247-269 in RACHOKI, A. & CHURCH, M., (editors), Alluvial Fans. A Field Approach. John Wiley & Sons, Chichester, 391p.
- HOOKE, R. LeB. 1967 Processes on arid-region alluvial fans. Journal of Geology 75(4): 438-460.
- HOOKE, R. LeB. 1968 Steady-state relationships on arid-region alluvial fans in closed basins. American Journal of Science 266: 609-629.
- HOOKE, R. LeB. 1972 Geomorphic evidence for Late-Wisconsin and Holocene tectonic deformation, Death Valley, California. Geological Society of America, Bulletin 83 (7): 2073-2098.
- HOOKE, R. LeB. & ROHRER, W. L. 1979 Geometry of alluvial fans: effect of discharge and sediment size. Earth Surface Processes 4: 147-166.
- HOPLEY, D. & THOM, B. G. 1983 Australian sea levels in the last 15 000 years: a review. Monograph Series, Occasional Papers, James Cook University of North Queensland, Department of Geography 3: 3-26.
- HORTON, R. E. 1945 Erosional development of streams and their drainage basins: hydrophysical approach to quantitative morphology. Geological Society of America, Bulletin 56: 275-370.
- HORWITZ, R. C. & DAILY, B. 1958 Yorke Peninsula. Chapter III, pp.46-60 in GLAESSNER, M. F. & PARKIN, L. W. (editors), The Geology of South Australia. Melbourne University Press for Geological Society of Australia, Victoria, 163p.
- HOWARD, A. D. 1942 Pediment passes and the pediment problem. Journal of Geomorphology 5(1): 3-31, (2): 95-136.
- HUBBLE, G. D., ISBELL, R. F. & NORTHCOTE, K. H. 1983 Features of Australian soils. Chapter 3, pp.17-47 in Division of Soils, CSIRO, Soils: an Australian Viewpoint. CSIRO: Melbourne/Academic Press, London, 928p.
- HULLETT, H. W. 1882 Statement of strata traversed by the boring made for obtaining waters at Waterworks Yard, Stirling North, near Pt. Augusta. Royal Society of South Australia, Transactions 5: 99-101.
- HUNT, C. B. & MABEY, D. R. 1966 General geology of Death Valley, California. United States Geological Survey, Professional Paper 494-A, 162p.



- HUTTON, J. T., TWIDALE, C. R. & MILNES, A. R. 1978 Characteristics and origin of some Australian silcretes, pp.19-30 in LANGFORD-SMITH, T. (editor), Silcrete in Australia. University of New England Press, Armidale, 314p.
- INSTITUTION OF ENGINEERS 1987 Australian Rainfall and Runoff. Volume 2. A Guide to Flood Estimation. Australian Government Printing Service, Canberra.
- JESSUP, R. W. & NORRIS, R. M. 1971 Cainozoic stratigraphy of the Lake Eyre Basin and part of the arid region lying to the south. Geological Society of Australia, Journal 18(3): 303-331.
- JOHNS, R. K. 1968a Investigation of Lakes Torrens and Gairdner. Geological Survey of South Australia, Report of Investigations 31, 90p.
- JOHNS, R. K. 1968b Geology and Mineral Resources of the Andamooka-Torrens Area. Geological Survey of South Australia, Bulletin 41, 103p.
- JOHNS, R. K., HIERN, M. N., NIXON, L. G., FORBES, B. G. & OLLIVER, J. G. 1964 TORRENS map sheet. Geological Atlas 1:250 000 Series, Sheet SH 53-16. Geological Survey of South Australia.
- JOHNS, R. K. & LUDBROOK, N. H. 1963 Investigation of Lake Eyre. Geological Survey of South Australia, Report of Investigations 24, 104p.
- JOHNSON, D. W. 1931 Planes of lateral corrasion. Science 73: 174-177.
- JOHNSON, D. W. 1932a Rock planes of arid regions. The Geographical Review 22: 656-665.
- JOHNSON, D. W. 1932b Streams and their significance. Journal of Geology 40: 481-497.
- JUTSON, J. T. 1917 Erosion and the resulting land forms in subarid Western Australia, including the origin and growth of the dry lakes. Geographical Journal 40: 418-437.
- KAR, A. 1984 Morphology and evolution of some sandstone pediments in Rajasthan Desert. Geographical Review of India 46: 67-74.
- KENDALL, G. W. 1968 The Motpena area of the Pirie-Torrens Basin. Mining Review, South Australia 124: 85-92.
- KENNEDY, B. A., 1978 After Horton. Earth Surface Processes, 3: 219-231.
- KING, L. C., 1942 Notes to accompany a topographical map of part of the Valley of a Thousand Hills, Natal. Natal Museum, Annals 10: 135.
- KING, L. C., 1949 The pediment landform: some current problems. Geological Magazine 86: 245-250.
- KING, L. C., 1953 Canons of landscape evolution. Geological Society of America, Bulletin 64: 721-752.
- KING, L. C., 1957 The uniformitarian nature of hillslopes. Edinburgh Geological Society, Transactions, 17: 81-102.
- KING L. C., 1962 Morphology of the Earth. Oliver and Boyd, Edinburgh-London, 699p.
- KING, L. C., 1966 The origin of bornhardts. Zeitschrift für Geomorphologie N.F. 10: 97-98.

- KING, L. C., 1968 Pediplanation, pp.818-820 in FAIRBRIDGE, R. W. (editor), The Encyclopaedia of Geomorphology. Encyclopaedia of Earth Sciences Series, Volume III, Reinhold Corporation, 1295p.
- KIRKBY, A. & KIRKBY, M. J. 1974 Surface wash at the semi-arid break in slope. *Zeitschrift für Geomorphologie, N.F., Supplementband 21*: 151-176.
- LARSEN, V. & STEEL, R. J. 1978 The sedimentary history of a debris-flow dominated, Devonian alluvial fan - a study of textural inversion. *Sedimentology* 25: 37-59.
- LAUT, P., HEYLIGERS, P.C., KEIG, G., LOFFLER, E., MARGULES, C., SCOTT, R.M. & SULLIVAN, M. E. (Compilers) 1977 Environments of South Australia. Province 5, Eastern Pastoral and Province 6, Flinders Ranges. Division of Land Use Research, C.S.I.R.O., Canberra, 219p.
- LAWSON, A. C. 1915 The epigene profiles of the desert. University of California Publications, Department of Geology, Bulletin 9(3): 23-48.
- LECCE, S. A. 1990 The alluvial fan problem. Chapter 1, pp. 3-24 in RACHOCKI, A. & CHURCH, M. (editors), *Alluvial Fans. A Field Approach*. John Wiley & Sons, Chichester, 391p.
- LEESON, B. 1970 Geology of the Beltana 1:63,360 map area. Geological Survey of South Australia, Report of Investigations 35, 92p.
- LEMON, N. M. 1985 Physical modelling of sedimentation adjacent to diapirs and comparison with late Precambrian Oratunga breccias body in Central Flinders Ranges, South Australia. *American Association of Petroleum Geologists* 69: 1327-1338.
- LEMON, N. M. 1988a Diapir recognition and modelling with examples from the late Proterozoic Adelaide Geosyncline, Central Flinders Ranges, South Australia. Ph.D. Thesis, University of Adelaide, South Australia (unpublished), 139p.
- LEMON, N. M. 1988b Tidal influences in the marginal Eromanga Basin. *Geological Survey of South Australia, Quarterly Geological Notes* 105: 7-11.
- LEMON, N. M. 1996 Geology, in TYLER, M. J., TWIDALE, C. R. & DAVIES, M. (editors), *Natural History of the Flinders Ranges*. Royal Society of South Australia, Adelaide. In press.
- LINDSAY, J. M. 1970 Melton Limestone: multiple mid-Tertiary transgressions, south-eastern Gawler Platform. *Geological Survey of South Australia, Quarterly Geological Notes* 33: 2-10.
- LUSTIG, L. K. 1965 Clastic sedimentation in Deep Springs Valley, California. U. S. Geological Survey Professional Paper 352-F: 131-192.
- LUSTIG, L. K. 1969 Trend surface analysis of the Basin and Range Province and some geomorphic implications. U.S. Geological Survey Professional Paper 500-D, 70p.
- MABBUTT, J. A. 1966 Mantle-controlled planation of pediments. *American Journal of Science* 264: 78-91.
- MABBUTT, J. A. 1967 Denudation chronology in Central Australia: structure, climate, and landform inheritance in the Alice Springs area, pp. 144-181 in JENNINGS, J. N. & MABBUTT, J. A. (editors), *Landform Studies in Australia and New Guinea*. ANU Press, Canberra, 434p.
- MABBUTT, J. A. 1978 Lessons from pediments, pp.331-347 in DAVIES, J. L. & WILLIAMS, M. A. J. (editors), *Landform Evolution in Australasia*. ANU Press, Canberra, 376p.

- MACKIN, J. H. 1937 Erosional history of the Big Horn Basin, Wyoming. Geological Society of America, Bulletin 48: 815-860.
- MACKIN, J. H. 1970 Origin of pediments in the Western United States, pp.85-105 in PECSI, M. (editor), Problems of Relief Planation. Akademiai Kiado, Budapest.
- MAMMERICKX, J. 1964 Quantitative observations on pediments in the Mojave and Sonoran deserts (southwestern United States). American Journal of Science 262: 417-435.
- MARTIN-SERRANO, A. 1991 The northwest border of the Duero Basin. Chapter 4.1, pp. 187-193 in GARZON, G., CENTENO, J. D. & ACASO, E. (editors), Geomorphological Problems of Central and Northwestern Iberian Peninsula. University Complutense, Madrid, 246p.
- McCUE, K. 1990 Australia's large earthquakes and Recent fault scarps. Journal of Structural Geology 12(5/6): 761-766.
- McELHINNY, M. W. 1973 Earth sciences and the Australian continent. Nature 246: 264-268.
- McGEE, W. J. 1897 Sheetflood erosion. Geological Society of America, Bulletin 8: 87-112.
- MELTON, M. A. 1965a Debris-covered hillslopes of the southern Arizona desert - consideration of their stability and sediment contribution. Journal of Geology 73: 715-729.
- MELTON, M. A. 1965b The geomorphic and palaeoclimatic significance of alluvial deposits in southern Arizona. Journal of Geology 73: 1-38.
- MENSCHING, H. 1970 Planation in arid subtropic and tropic regions, pp. 73-84 in PECSI, M. (editor), Problems of Relief Planation. Akademiai Kiado, Budapest.
- MENSCHING, H. 1978 Inselberge, Pedimente und Rumpfflachen im Sudan (Republik). Zeitschrift für Geomorphologie, Supplementband 30: 1-19.
- MIALL, A. D. 1981 Alluvial sedimentary basins: tectonic setting and basin architecture, pp.1-33 in MIALL, A. D. (editor), Sedimentation and Tectonics in Alluvial Basins. Geological Association of Canada, Special Paper 23, 272p.
- MILES, K. R. 1952 Tertiary faulting in north-eastern Eyre Peninsula, South Australia. Royal Society of South Australia, Transactions 75: 89-96.
- MILLER, V. C. 1950 Pediments and pediment-forming processes near House Rock, Arizona. Journal of Geology 58(6): 634-645.
- MILTON, B. E., TOWNSEND, I. J., THORNTON, R. C. N. & YOUNGS, B. C. 1973 A summary of certain sedimentary basins in South Australia. South Australian Department of Mines & Energy, Report Book 73/304 (unpublished).
- MOORE, P. S. 1979 Deltaic sedimentation - Cambrian of South Australia. Journal of Sedimentary Petrology 49: 1229-1244.
- MORISAWA, M. 1968 Streams their dynamics and morphology. Earth and Planetary Science Series. McGraw-Hill Book Company, New York, 175p.
- MOSS, J. H. 1977 The formation of pediments: scarp backwearing or surface downwasting? pp.51-78 in DOEHRING, D. O. (editor), Geomorphology in Arid Regions. George Allen & Unwin, London, 272p.

- MOSS, J. H. & BONINI, W. 1961 Seismic evidence supporting a new interpretation of the Cody terrace near Cody, Wyoming. *Geological Society of America, Bulletin* 72: 547-556.
- MOUNT, T. J. 1975 Diapirs and Diapirism in the 'Adelaide Geosyncline'. Ph.D. Thesis, University of Adelaide, South Australia (unpublished), 237p.
- MUKERJI, A. B. 1990 The Chandigarh Dun alluvial fans: an analysis of the process-form relationship. Chapter 7, pp.131-149 in RACHOCKI, A. H. & CHURCH, M. (editors), *Alluvial Fans. A Field Approach*. John Wiley & Sons, Chichester, 391p.
- MUNSELL COLOR 1975 *Munsell Soil Color Charts*. Macbeth Division, Kellmorgen Corporation, Baltimore, Maryland.
- MURRELL, B. 1977 Stratigraphy and tectonics across the Torrens Hinge Zone between Andamooka and Marree, South Australia. Ph.D. Thesis, University of Adelaide, South Australia (unpublished), 192p.
- NAKADA, M. & LAMBECK, K. 1989 Late Pleistocene and Holocene sea-level change in the Australian region and mantle rheology. *Geophysical Journal* 96: 497-517.
- NILSEN, T. H., & MOORE, T. E. 1984 *Bibliography of Alluvial-Fan Deposits*. Geo Books, Norwich, 96p.
- NORRIS, R. M. 1969 Dune reddening and time. *Journal of Sedimentary Petrology* 39(1): 7-11.
- OBERLANDER, T. 1972 Morphogenesis of granitic boulder slopes in the Mojave Desert, California. *Journal of Geology* 80: 1-20.
- OBERLANDER, T. 1974 Landscape inheritance and the pediment problem in the Mojave Desert of southern California. *American Journal of Science* 274: 849-875
- O'DRISCOLL, E. S. T. 1981 Structural corridors in Landsat lineament interpretation. *Mineralium Deposita* 16: 85-101.
- O'DRISCOLL, E. S. T. 1983 Deep tectonic foundations of the Eromanga Basin. *Australian Petroleum Exploration Association Journal* 23(1): 5-17.
- O'DRISCOLL, E. S. T. 1986 Observations of the lineament-ore relation. *Royal Society, London, Philosophical Transactions A* 317: 195-218.
- OGILVIE, I. H. 1905 The high altitude conoplain; a topographic form illustrated in the Ortiz Mountains. *American Geologist* 36: 27-34.
- ÖPIK, A. A. 1961 The geology and palaeontology of the headwaters of the Burke River, Queensland. *Australia Bureau of Mineral Resources Geology and Geophysical, Bulletin* 53, 249p.
- OSBORN, G. & DU TOIT, C. 1991 Lateral planation of rivers as a geomorphic agent. *Geomorphology* 4: 249-260.
- OSBORN, S. B. & LAURSEN, E. M. 1973 Thunderstorm runoff in southern Arizona. *American Society of Civil Engineers, Proceedings* 99, HY 7:1129-1145.
- PACK, F. J. 1923 Torrential potential of desert waters. *Pan-American Geologist* 40: 349-356.
- PAIGE, S. 1912 Rock-cut surfaces in the desert ranges. *Journal of Geology* 20(5): 442-450.

- PANNEKOEK, A. J. 1970 The application of graphical methods to the piedmont relief of the Cantabrian Mountains, Spain. *Zeitschrift für Geomorphologie, Supplementband 10*: 88-103.
- PARKER, F. 1987 Palynology of selected borehole samples in the Leigh Creek area. South Australian Department of Mines, Envelope 6810 (unpublished).
- PARSONS, A. J. & ABRAHAMS, A. D. 1984 Mountain mass denudation and piedmont formation in the Mojave and Sonoran deserts. *American Journal of Science* 284: 255-271.
- PARTRIDGE, T. C. & MAUD, R. R. 1987 Geomorphic evolution of southern Africa since the Mesozoic. *Geological Society of South Africa, Transactions* 90: 179-208.
- PEEL, R. F. 1941 Denudation landforms of the central Libyan Desert. *Journal of Geomorphology*, 4: 3-23.
- PEGUM, D. M. 1957 Santos Ltd. Detailed Gravity Survey - Motpena area. South Australian Department of Mines & Energy, Envelope 121 (unpublished).
- PETTIJOHN, F. J., POTTER, P. E., & SIEVER, R. 1987 Mineral and chemical composition. Chapter 2, pp.25-67 in *Sand and Sandstone*. Springer-Verlag, New York, 553p.
- POWELL, J. W. 1875 Exploration of the Colorado River of the West and its tributaries. Explored in 1869, 1870, 1871 and 1872. Government Printing Office, Washington, D.C., 160p.
- PREISS, W. V. (compiler) 1987 The Adelaide Geosyncline - late Proterozoic stratigraphy, sedimentation, palaeontology and tectonics. *Geological Survey of South Australia, Bulletin* 53, 438p.
- PREISS, W. V. & FAULKNER, P. 1984 Geology, geophysics and stratigraphic drilling at Depot Creek, southern Flinders Ranges. *Geological Survey of South Australia, Quarterly Geological Notes* 89: 10-19.
- PUGH, J. C. 1956 Fringing pediments and marginal depressions in the inselberg landscape of Nigeria. *Institute of British Geographers, Transactions & Papers* 22: 15-31.
- RACHOCKI, A. 1981 *Alluvial Fans*. John Wiley & Sons, New York, 161p.
- RACHOCKI, A. & CHURCH, M. (editors) 1990 *Alluvial Fans. A Field Approach*. John Wiley & Sons, Chichester, 391p.
- RAHN, P. H. 1966 Inselbergs and nickpoints in south western Arizona. *Zeitschrift für Geomorphologie N.F.* 10: 217-225.
- RAHN, P. H. 1967 Sheetfloods, streamfloods, and the formation of pediments. *Association of American Geographers, Annals* 57(3): 593-604.
- REINECK, H. E. & SINGH, I.B. 1973 *Depositional Sedimentary Environments*. Springer-Verlag, Berlin, Heidelberg, New York, 439p.
- RICH, J. L. 1935 Origin and evolution of rock fans and pediments. *Geological Society of America, Bulletin* 46: 999-1024.
- RICH, J. L. 1938 Recognition and significance of multiple erosion surfaces. *Geological Society of America, Bulletin* 49: 1695-1722.
- RISELY, B. G. 1965 Reconnaissance Seismic Refraction Survey - Lake Torrens. *Mining Review, South Australia* 118: 91-94.

- RISELY, B. G. 1967 A geophysical investigation at the southern end of Lake Torrens in a search for brines. *Mining Review, South Australia* 120: 86-93.
- RITTER, D. F. 1978 *Process Geomorphology*. Wm. C. Brown Company Publishers, Dubuque, Iowa, 603p.
- RUHE, R. V. 1964 Landscape morphology and alluvial deposits in southern New Mexico. *Association of American Geographers, Annals* 54: 147-159.
- RUSSELL, R. J. 1936 The desert-rainfall factor in denudation. 16th International Geological Congress, Report 2: 753-763.
- RUTLAND, R. W. R. 1973 Tectonic evolution of the continental crust of Australia. Chapter 10.3, pp.1011-1033 in TARLING, D. H. & RUNCORN, S. K. (editors), *Implications of Continental Drift to the Earth Sciences, Volume 2*. Academic Press, London & New York, 1184p.
- RYDER, J. M. 1971 The stratigraphy and morphology of paraglacial alluvial fans in south-central British Columbia. *Canadian Journal of Earth Science* 8: 279-298.
- SAH, M. P., & SRIVASTAVA, R. A. K. 1992 Morphology and facies of the alluvial-fan sedimentation in the Kangra Valley, Himachal Himalaya. *Sedimentary Geology* 76: 23-42.
- SCHLUTER, C., BYE, J. A. T. & HARBISON, P. 1995 The most vigorous tide. *Royal Society of South Australia, Transactions* 119(3): 123-132.
- SCHMID, R. M. 1985 Lake Torrens, South Australia: Sedimentation and Hydrology. Ph.D. Thesis, Flinders University of South Australia (unpublished), 251p.
- SCHUMM, S. A. 1956 Evolution of drainage systems and slopes in badlands at Perth Amboy, N.J. *Geological Society of America, Bulletin* 67: 597-646.
- SCHUMM, S. A. 1962 Erosion on miniature pediments in Badlands National Monument, South Dakota. *Geological Society of America, Bulletin* 73: 719-724.
- SCHUMM, S. A., 1977 *The Fluvial System*. John Wiley & Sons, New York. 338p.
- SCHUMM, S. A., MOSLEY, M. P. & WEAVER, W. E. 1987 *Experimental Fluvial Geomorphology*. John Wiley & Sons, New York, 413p.
- SHACKLETON, N. J. 1986 The Plio-Pleistocene ocean: stable isotope history, in HSÜ, K. J. (editor), *Mesozoic and Cenozoic Oceans*. American Geophysical Union and Geological Society of America, *Geodynamics Series* 15: 141-153.
- SHARON, D. 1972 The spottiness of rainfall in a desert area. *Journal of Hydrology* 17: 161-175.
- SHARP, R. P. 1940 Geomorphology of the Ruby-East Humboldt Range. *Geological Society of America, Bulletin* 51: 337-371.
- SHARP, R. P. 1957 Geomorphology of Cima Dome, Mojave Desert, California. *Geological Society of America, Bulletin* 68: 273-289.
- SHREVE, F. 1934 Rainfall, runoff, and soil moisture under desert conditions. *Association of American Geographers, Annals* 24: 131-156.
- SHREVE, R. L. 1966 Statistical law of stream numbers. *Journal of Geology* 74: 17-37.
- SIBENALER, X. P. 1979 Hawker - Marree Highway groundwater supply. Moralana-Parachilna Section. Geological Survey. South Australian Department of Mines & Energy, Report Book 79/52 (unpublished).

- SMITH, K. G. 1958 Erosional processes and landforms in Badlands National Monument, South Dakota. Geological Society of America, Bulletin 69: 975-1008.
- SPRINGER, M. E. 1958 Desert pavement and vesicular layer of some soils of the desert of the Lahontan Basin, Nevada. Soil Science Society of America, Proceedings 22: 63-66.
- STEWART, I. C. F. 1972 Seismic interpretation of crustal structure in the Flinders-Mt Lofty Ranges and Gulf regions, South Australia. Geological Society of Australia, Journal 19(3): 351-362.
- STEWART, I. C. F., SLADE, A. & SUTTON, D. J. 1973 South Australian seismicity 1967-1971. Geological Society of Australia, Journal 19: 441-457.
- STRAHLER, A. N. 1952 Hypsometric (area-altitude) analysis of erosional topography. Geological Society of America, Bulletin 63: 1117-1142.
- STRAHLER, A. N. 1957 Quantitative analysis of watershed geomorphology. American Geophysical Union, Transactions 38: 913-920.
- SUKANTA, U. 1987 Depositional environment, palaeogeography and syndepositional tectonics of Emeroo Subgroup Late Proterozoic, South Australia. M.Sc. Thesis, Flinders University of South Australia, 2 volumes (unpublished), 377p.
- SURELL, A. 1841 Étude sur les Torrents de Hautes Alpes. First Edition, Paris; cited by BULL, W. B., 1977. loc. cit. ante.
- SUTTON, D. J. & WHITE, R. E. 1968 The seismicity of South Australia. Geological Society of Australia, Journal 15: 25-32.
- SWIFT, D. G. 1987 ETSA. EL 1364 - Lake Torrens Quarterly Report to 10 February 1987. South Australian Department of Mines & Energy, Envelope 6810, Volume I (unpublished).
- TATOR, B. A. 1952a Pediment characteristics and terminology. Part I Pediment characteristics. American Association of Geographers, Annals 42: 295-317.
- TATOR, B. A. 1952b Piedmont interstream surfaces of the Colorado Springs region, Colorado. Geological Society of America, Bulletin 63: 255-274.
- TATOR, B. A., 1953 Pediment characteristics and terminology. Part II Terminology. American Association of Geographers, Annals 43: 47-53.
- THOMSON, B. P. 1966 The lower boundary of the Adelaide System and older basement relationships in South Australia. Journal of the Geological Society of Australia 13(1): 203-228.
- THOMSON, B. P. 1969a Precambrian crystalline basement, pp. 21-48 in PARKIN, L. W. (editor), Handbook of South Australian Geology. Geological Survey of South Australia, Adelaide, 268p.
- THOMSON, B. P. 1969b Precambrian basement cover: the Adelaide System, pp. 49-83 in PARKIN, L. W. (editor), Handbook of South Australian Geology. Geological Survey of South Australia, Adelaide, 268p.
- THOMSON, B. P. 1970 A review of the Precambrian and Lower Palaeozoic tectonics of South Australia. Royal Society of South Australia, Transactions 94: 193-221.
- THOMSON, B. P. 1973 Ore deposits in relation to the tectonic development of eastern Australia. B.M.R., Geology and Geophysics, Bulletin 141: 95-105.
- THOMSON, B. P., COATS, R. P., MIRAMS, R. C., FORBES, B. G., DALGARN, C. R. & JOHNSON, J. E. 1964 Precambrian rock groups in the Adelaide

- Geosyncline: a new subdivision. Geological Survey of South Australia, Quarterly Geological Notes 9: 1-19.
- THOMSON, B. P., DAILY, B., COATS, R. P. & FORBES, B. G. 1976 Late Precambrian and Cambrian geology of the Adelaide "Geosyncline" and Stuart Shelf, South Australia. 25th International Geological Congress, Excursion Guide No.33A, 54p.
- THORNTHWAITE, C. W. 1937 The life history of rain storms. The Geographical Review 27: 92-111.
- TROEH, F. R. 1965 Landform equations fitted to topographic maps. American Journal of Science 263: 616-627.
- TROWBRIDGE, A. C. 1911 The terrestrial deposits of Owens Valley, California. Journal of Geology 19: 706-747.
- TUAN, YI-FU 1959 Pediments in southeastern Arizona. University of California Publications in Geography 13: 1-164.
- TUAN, YI-FU 1962 Structure, climate, and basin land forms in Arizona and New Mexico. American Association of Geographers, Annals 52(1): 51-68.
- TWIDALE, C. R. 1962 Steepened margins of inselbergs from northwestern Eyre Peninsula, South Australia. Zeitschrift für Geomorphologie, 6: 51-69.
- TWIDALE, C. R. 1966a Chronology of denudation in the southern Flinders Ranges, South Australia. Royal Society of South Australia, Transactions 90: 3-32.
- TWIDALE, C. R. 1966b Geomorphology of the Leichhardt-Gilbert Area of Northwest Queensland. Land Research Series 16, CSIRO, Melbourne, 56p.
- TWIDALE, C. R. 1967a Origin of the piedmont angle as evidenced in South Australia. Journal of Geology 75: 393-411.
- TWIDALE, C. R. 1967b Hillslopes and pediments in the Flinders Ranges, South Australia, pp.95-117 in JENNINGS, J. N. & MABBUTT, J. A. (editors), Landform Studies in Australia and New Guinea. ANU Press, Canberra, 434p.
- TWIDALE, C. R. 1969 Geomorphology of the Flinders Ranges, pp.57-137 in CORBETT, D. W. P. (editor), The Natural History of the Flinders Ranges. Libraries Board of South Australia, Adelaide, 356p.
- TWIDALE, C. R. 1972 The neglected third dimension. Zeitschrift für Geomorphologie N.F. 16: 283-300.
- TWIDALE, C. R. 1978 On the origin of pediments in different structural settings. American Journal of Science 278: 1138-1176.
- TWIDALE, C. R. 1979 The character and interpretation of some pediment mantles. Sedimentary Geology 22: 1-20.
- TWIDALE, C. R. 1980 Landforms, pp.13-41 in CORBETT, D. W. P. (editor), A Field Guide to the Flinders Ranges. Rigby, Adelaide, 368p.
- TWIDALE, C. R. 1981 Origins and environments of pediments. Geological Society of Australia, Journal 28: 423-434.
- TWIDALE, C. R. 1982a The evolution of bornhardts. American Scientist 70: 268-276.
- TWIDALE, C. R. 1982b Les inselbergs a gradins et leur signification: l'exemple de l'Australie. Annales de Geographie, 91: 657-678.



- TWIDALE, C. R. 1983a Pediments, peneplains and ultiplains. *Revue de Géomorphologie Dynamique* 32: 1-35.
- TWIDALE, C. R. 1983b Australian laterites and silcretes: ages and significance. *Revue de Géologie Dynamique et de Géographie Physique* 24(1): 35-45.
- TWIDALE, C. R. 1987 Genesis of covered pediments: an alternative to Sakaguchi's climatic interpretation. Department of Geography University of Tokyo, *Bulletin* 19: 71-74.
- TWIDALE, C. R. 1991 Gondwana landscapes: definition, dating and implications, pp.225-263, in RADNAKRISHNA, B. P. (editor), *The World of Martin F. Glaessner*. Geological Society of India, Memoir 20.
- TWIDALE, C. R. & BOURNE, J. A. 1975 Episodic exposure of inselbergs. *Geological Society of America, Bulletin*, 86: 1473-1481.
- TWIDALE, C. R. & BOURNE, J. A. 1978 Bornhardts. *Zeitschrift für Geomorphologie SupplementBand* 31: 111-137.
- TWIDALE, C. R. & BOURNE, J. A. 1996 The development of the land surface, in TYLER, M. J., TWIDALE, C. R. & DAVIES, M. (editors), *Natural History of the Flinders Ranges*. Royal Society of South Australia, Adelaide. In press
- TWIDALE, C. R. & CAMPBELL, E. M. 1988 Ancient Australia. *GeoJournal* 16(4): 339-354.
- TWIDALE, C. R. & CAMPBELL, E. M. 1992 Geomorphological development of the eastern margin of the Australian craton. *Earth Surface Processes and Landforms* 17: 419-431.
- TWIDALE, C. R., CAMPBELL, E. M. & FOALE, M. R. 1986 Landforms, pp. 48-49 in GRIFFIN, T. L. C. & McCASKILL, M. (editors), *Atlas of South Australia*. Government Printer, Adelaide, 134p.
- TWIDALE, C. R., SHEPHERD, J. A. & THOMPSON, R. M. 1970 Geomorphology of the southern part of the Arcoona Plateau and of the Tent Hill region west and north of Port Augusta, South Australia. *Royal Society of South Australia, Transactions* 94: 55-67.
- VAKIL, P. P. 1983 Moage Ltd. Well Completion Report. Old Motpena No. 1. South Australian Department of Mines & Energy, Envelope 5877 (unpublished).
- VAN OVERMEEREN, R. A. & STAAL, J. H. 1976 Floodfan sedimentation and gravitational anomalies in the Salar de Punta Negra, northern Chile. *Geologische Rundschau* 65: 195-211.
- VEEVERS, J. J. (editor) 1984 *Phanerozoic Earth History of Australia*. Clarendon Press, Oxford, 418p.
- WAHLSTROM, E. E. 1947 Cenozoic physiographic history of the Front Range, Colorado. *Geological Society of America, Bulletin* 58: 551-572.
- WAIBEL, L. 1928 Die inselberglandschaft von Arizona and Sonora (The inselberg landscape of Arizona and Sonora). *Zeitschrift Gesell. Erdkunde Berlin Jubiläums Sonderband*, 68-91.
- WALKER, T. R. 1979 Red color in dune sand. Chapter D, pp.61-81 in McKEE, E. D. (editor), *A Study of Global Sand Seas*. United States Geological Survey, Professional Paper 1052, 429p.
- WARNKE, D. A. 1969 Pediment evolution in the Halloran Hills, central Mojave Desert, California. *Zeitschrift für Geomorphologie N.F.* 13: 357-389.

- WASSON, R. J. 1974 Intersection point deposition on alluvial fans: an Australian example. *Geografiska Annaler* 56A(1-2): 83-92.
- WASSON, R. J. 1977a Last-glacial alluvial fan sedimentation in the lower Derwent Valley, Tasmania. *Sedimentology* 24: 781-799.
- WASSON, R. J. 1977b Catchment processes and the evolution of alluvial fans in the lower Derwent valley, Tasmania. *Zeitschrift für Geomorphologie* 21(2): 147-168.
- WEAVER, W. E., & SCHUMM, S. A. 1974 Fanhead trenching: an example of a geomorphic threshold. *Geological Society of America, Abstracts with Programs* 6: 481.
- WEBB, B. P. 1958 Summary of tectonics and sedimentation. Chapter XI, pp.136-148 in GLAESSNER, M. F. & PARKIN, L. W. (editors), *The Geology of South Australia*. Melbourne University Press for Geological Society of Australia, Victoria, 163p.
- WEBB, B. P. 1961 Diapiric structures in the Flinders Ranges, South Australia. *Royal Society of South Australia, Transactions* 85: 1-6.
- WEBB, B. P. & VON DER BORCH, C. C. 1962 'Willochra' map sheet. *Geological Atlas 1:63 360 Series*. Geological Survey of South Australia.
- WELLMAN, P. & GREENHALGH, S. A. 1988 Flinders/Mount Lofty Ranges, South Australia: their uplift, erosion and relationship to crustal structure. *Royal Society of South Australia, Transactions* 112(1): 11-19.
- WELLS, S. G. & HARVEY, A. M. 1987 Sedimentologic and geomorphic variations in storm-generated alluvial fans, Howgill Fells, northwest England. *Geological Society of America, Bulletin* 98: 182-198.
- WHITAKER, C. R. 1973 Pediments: a bibliography. *Geo Abstracts Ltd., England*, 95p.
- WHITAKER, C. R. 1975 Pediment form and evolution in the east Kimberleys: granite, basalt, and sandstone case-studies. Ph.D Thesis, Australian National University, Canberra (unpublished), pp.1-26.
- WILLGOOSE, G., BRAS, R. L. & RODRIGUEZ-ITURBE, I. 1991 Results from a new model of river basin evolution. *Earth Surface Processes and Landforms* 16: 237-254.
- WILLIAMS, G. E. 1969 Characteristics and origin of a Precambrian pediment. *Journal of Geology* 77(2): 183-207
- WILLIAMS, G. E. 1970 Piedmont sedimentation and the late Quaternary chronology in the Biskra region of the northern Sahara. *Zeitschrift für Geomorphologie* 10: 40-63.
- WILLIAMS, G. E. 1973 Late Quaternary piedmont sedimentation, soil formation and palaeoclimates in arid South Australia. *Zeitschrift für Geomorphologie* 17(1): 102-125.
- WILLIAMS, G. E. & POLACH, H. A. 1971 Radiocarbon dating of arid-zone calcareous palaeosols. *Geological Society of America, Bulletin* 82: 3069-3086.
- WINTERER, E. L. & VON DER BORCH, C. C. 1968 Striated pebbles in a mudflow deposit, South Australia. *Palaeogeography, Palaeoclimatology, Palaeoecology* 5: 205-211.
- WOOD, A. 1942 The development of hillside slopes. *Geological Association of London, Proceedings* 53: 28-138.

- WOODARD, G. D. 1955 The stratigraphic succession in the vicinity of Mt Babbage, South Australia. Royal Society of South Australia, Transactions 78: 8-17.
- WOPFNER, H. 1972 Depositional history and tectonics of South Australian sedimentary basins. Mineral Review, South Australia 133: 32-50.
- WOPFNER, H., CALLEN, R. & HARRIS, W. K. 1974 The Lower Tertiary Eyre Formation of the southwestern Great Artesian Basin. Geological Society of Australia, Journal 21(1): 17-51.
- WOPFNER, H. & TWIDALE, C. R. 1967 Geomorphological history of the Lake Eyre Basin. Chapter 7, pp.118-143 in JENNINGS, J. N. & MABBUTT, J. A. (editors), Landform Studies from Australia and New Guinea. ANU Press, Canberra, 434p.
- YOUNG, A. 1972 Slopes. Oliver & Boyd, Edinburgh, 288p.

## FIGURES

Figure 1.1

Location map (base map: Griffin & McCaskill, 1986, p.49).

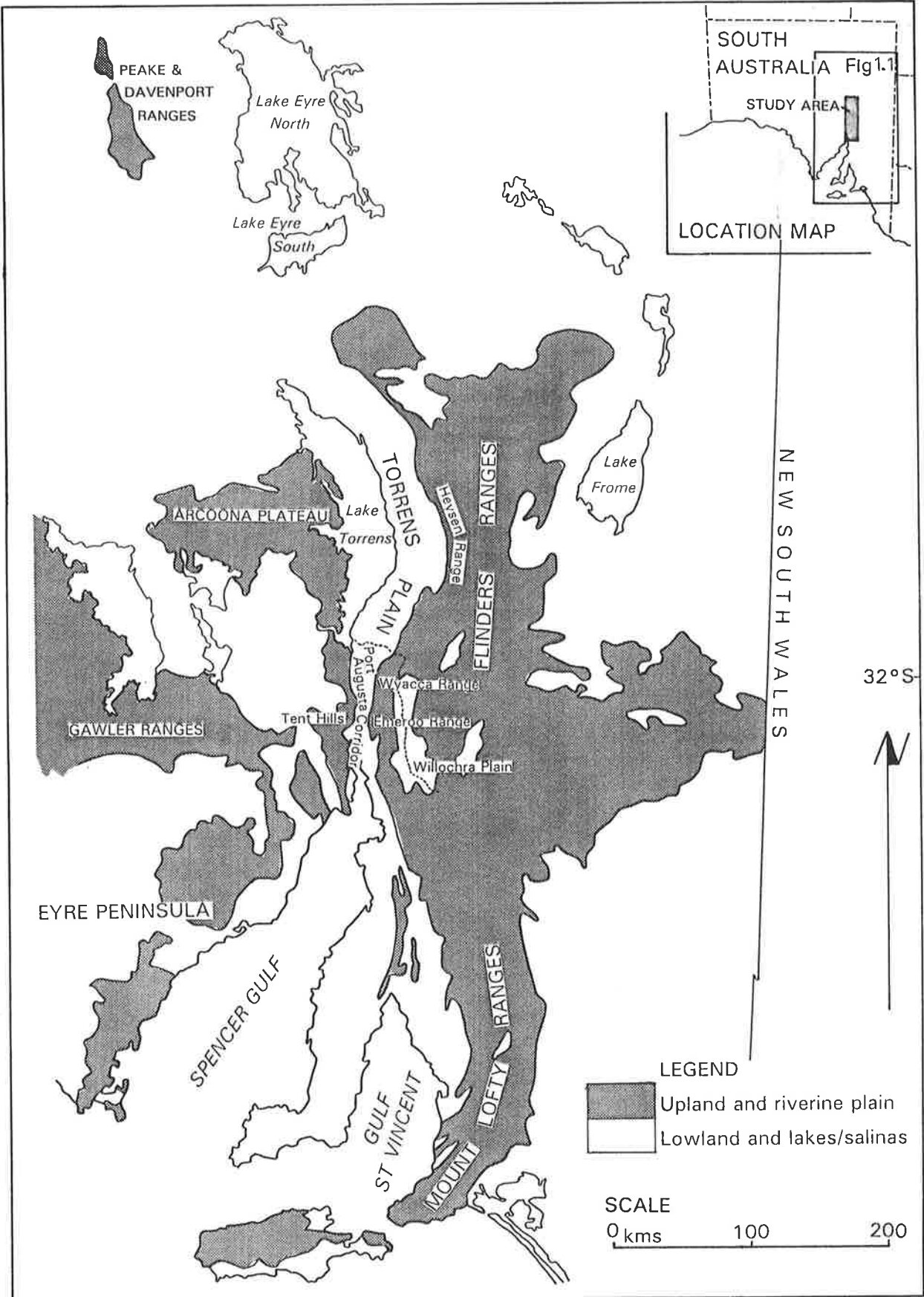


Figure 1.2

Tectonic geology map (after Griffin & McCaskill, 1986, p.47) Inset map A: Lineaments and three major gravity corridors (G-) affect the Adelaide Geosyncline (after O'Driscoll, 1983, p.7). Inset map B: Structural regions of South Australia (after Preiss, 1987).

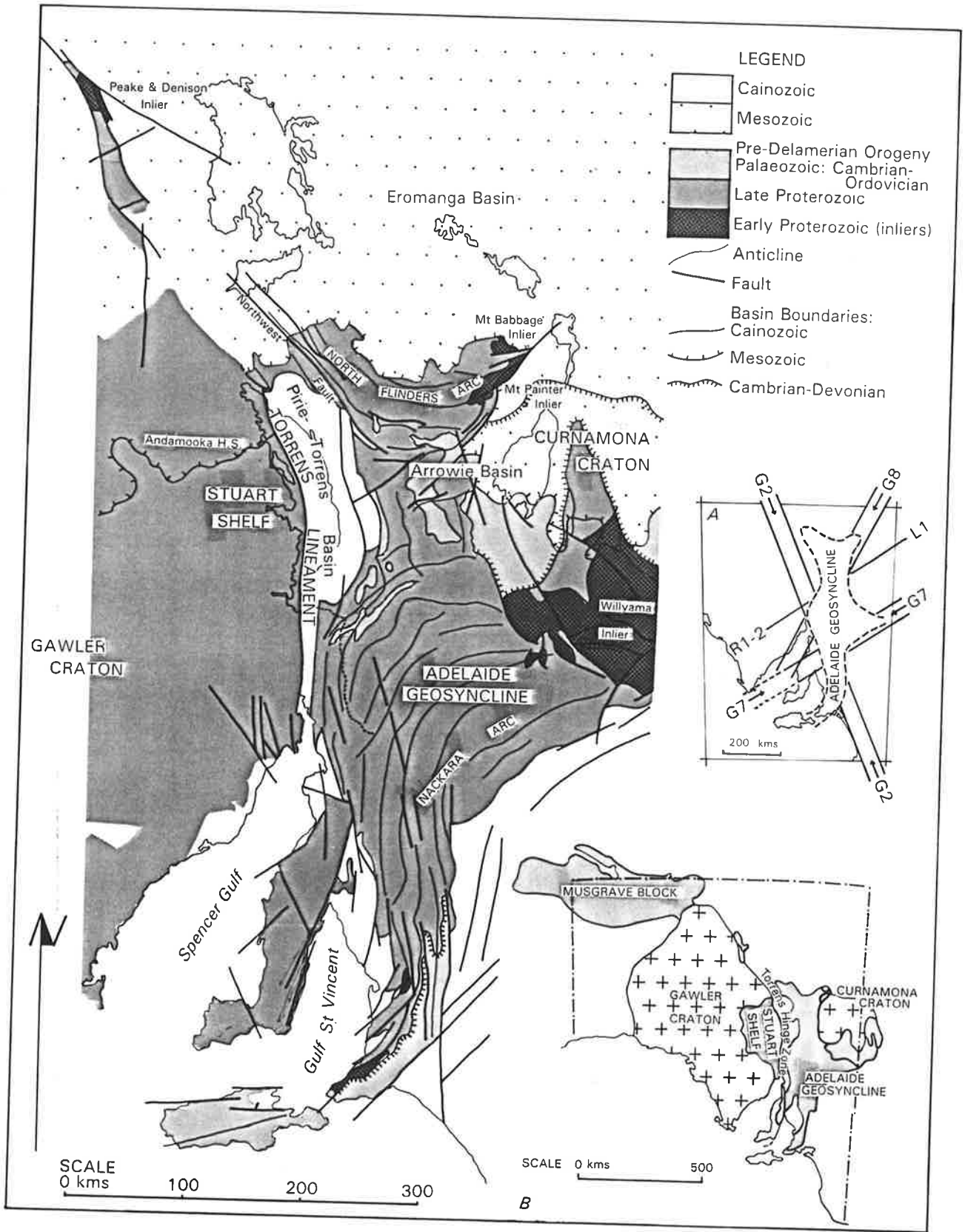
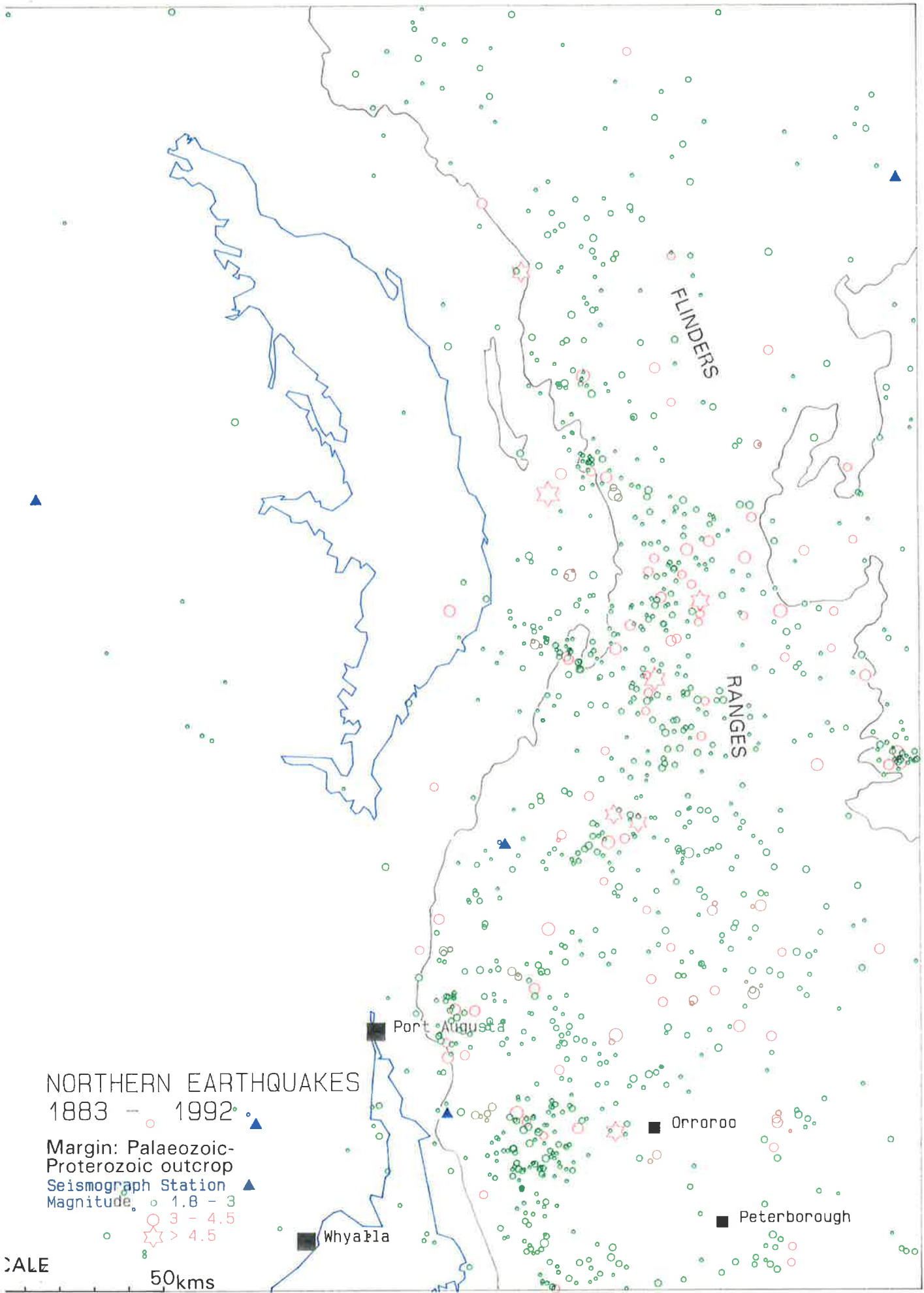




Figure 1.3

All earthquake epicentres recorded 1883-1992 in the Lake Torrens region (Geophysics Branch, Department of Mines and Energy, South Australia).



NORTHERN EARTHQUAKES  
1883 - 1992

- Margin: Palaeozoic-Proterozoic outcrop
- Seismograph Station
- Magnitude:
  - 1.8 - 3
  - 3 - 4.5
  - ☆ > 4.5

SCALE  
50kms

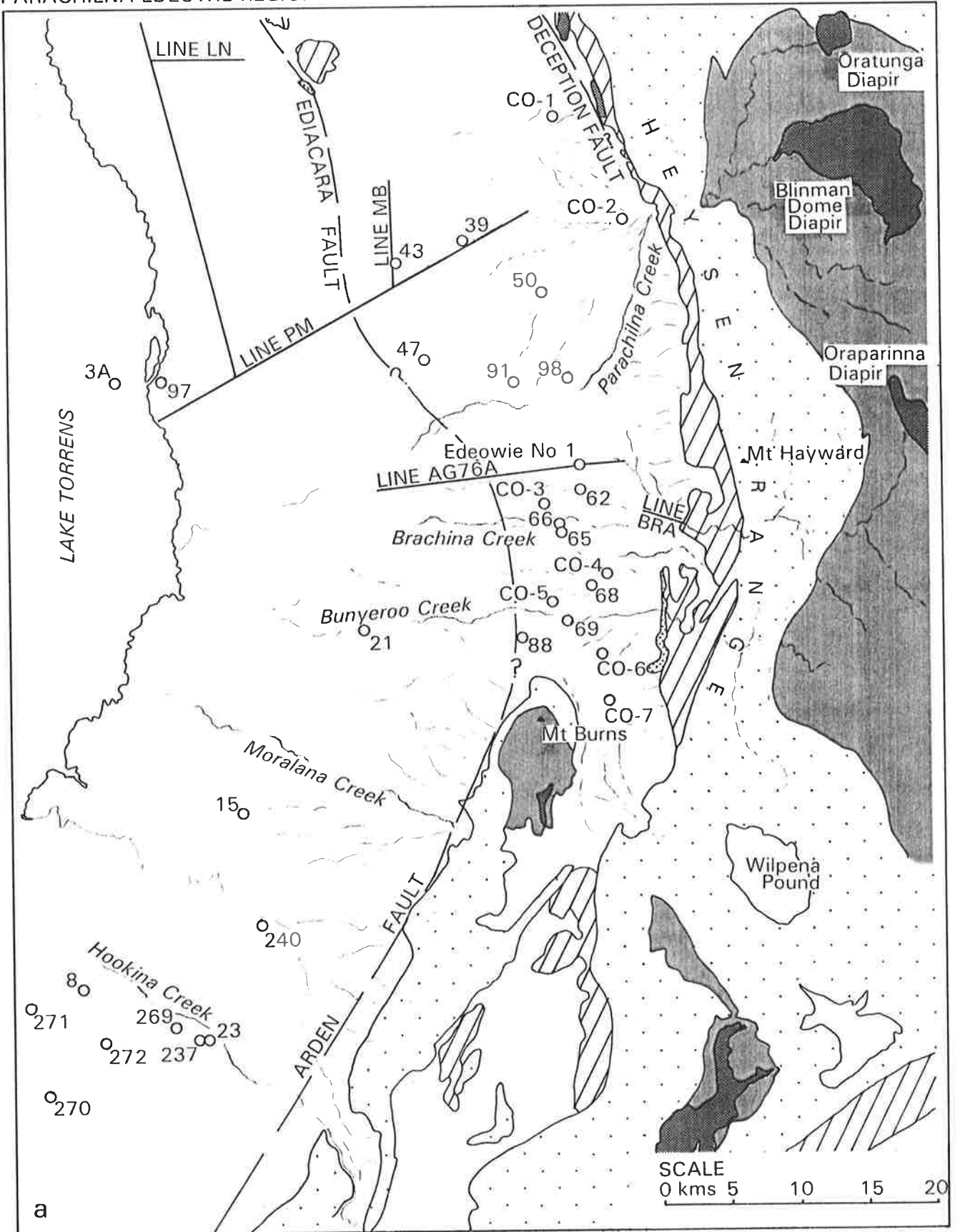
Figure 1.4

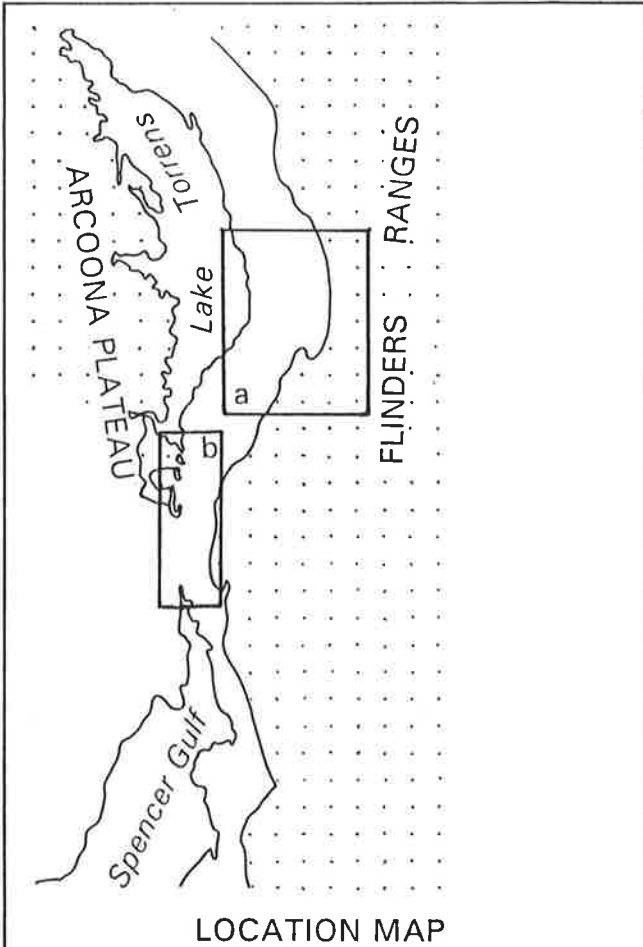
Geologically logged bore locations, seismic survey lines, major faults and generalised geology in and adjacent to the study area

(a) Parachilna-Edeowie region (after Dalgarno & Johnson, 1966; Cockshell, 1983; Hydrology Section, Department of Mines and Energy, South Australia)

(b) Wyacca-Emeroo region (after Dalgarno *et al.*, 1968; Hydrology Section, Department of Mines and Energy, South Australia).

PARACHILNA-EDEOWIE REGION





WYACCA-EMEROO REGION

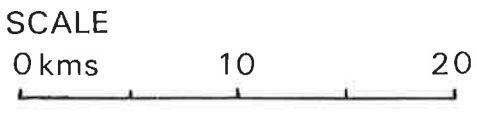
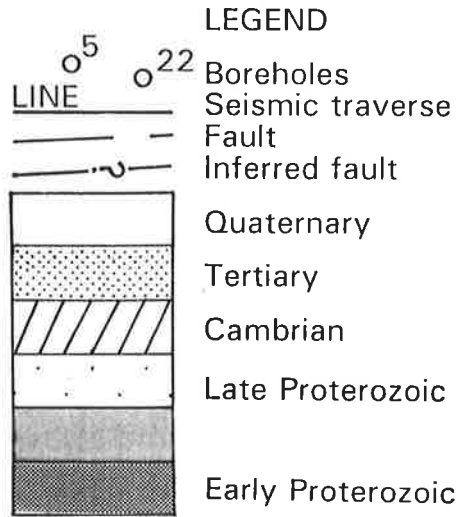
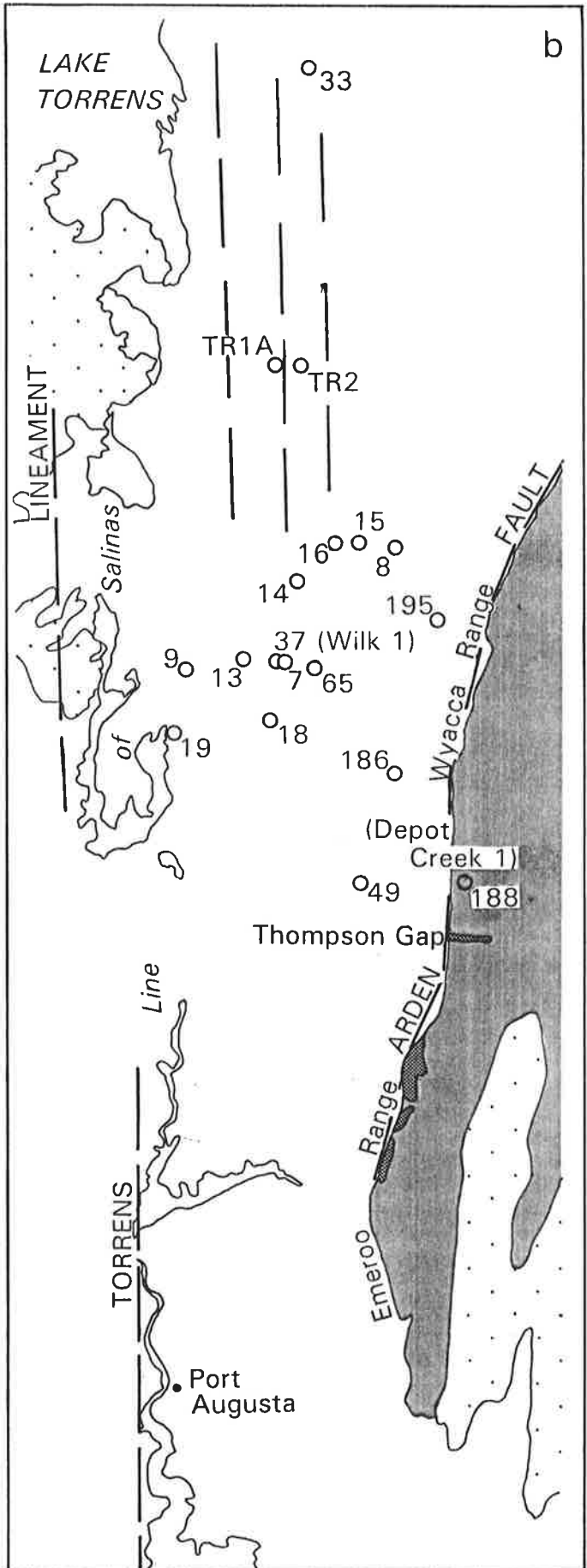


Figure 1.5

View north from Stokes Hill Lookout of summit surface, central Flinders Ranges. Resistant ridges and knolls, for example Patawarta Hill (left skyline), stand above the high plains.



Figure 1.6

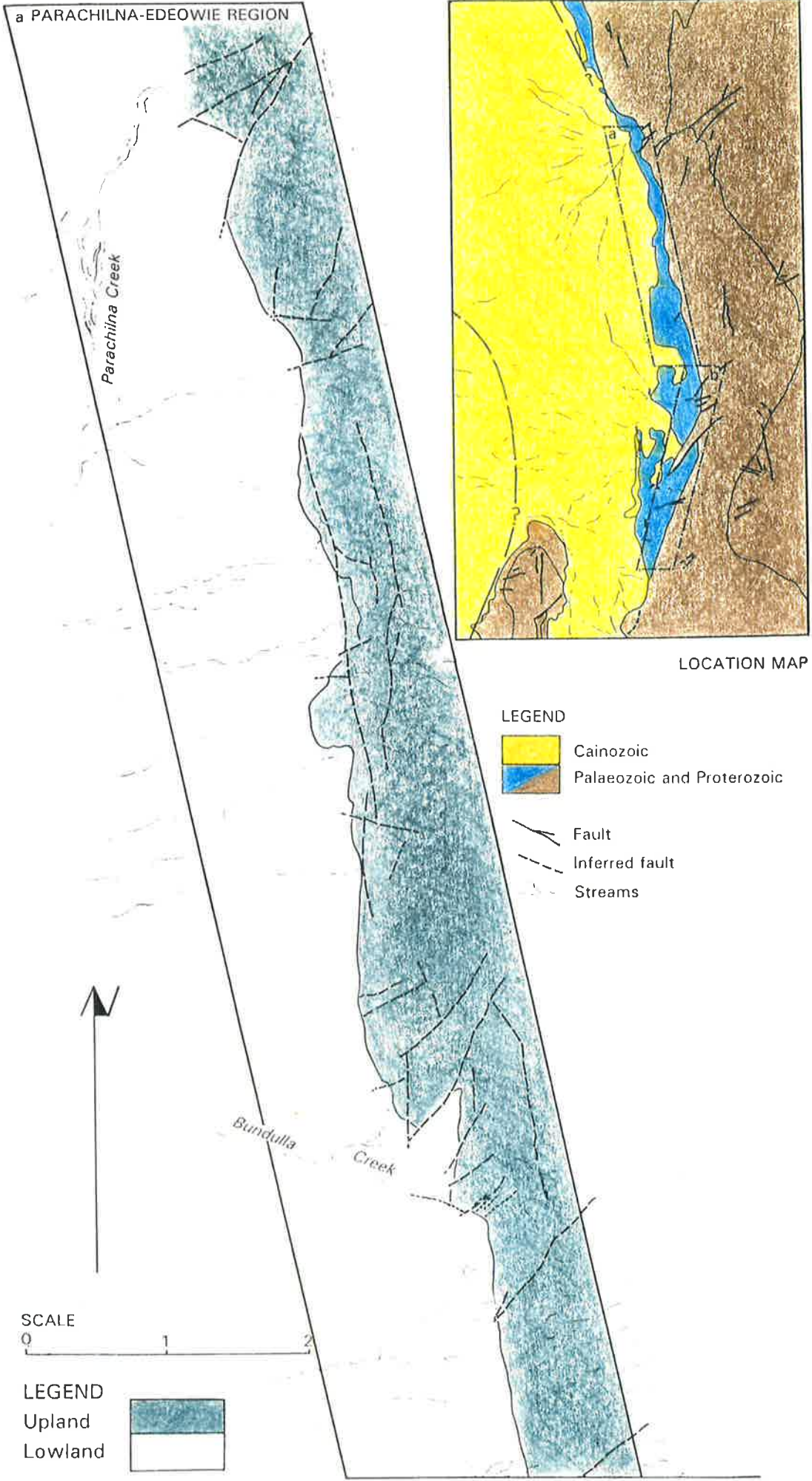
Short, *en echelon* faults indicate possible thrusting and rotational movements:

(a) Parachilna-Edeowie region: between Parachilna and Brachina creeks (after Dalgarno & Johnson, 1966; Anonymous, 1982)

(b) Parachilna-Edeowie region: between Brachina and Edeowie creeks (after Dalgarno & Johnson, 1966; Anonymous, 1982)

(c) Wyacca-Emeroo region (after Dalgarno *et al.*, 1968; Williams, 1973; Preiss & Faulkner, 1984; Sukanta, 1987).

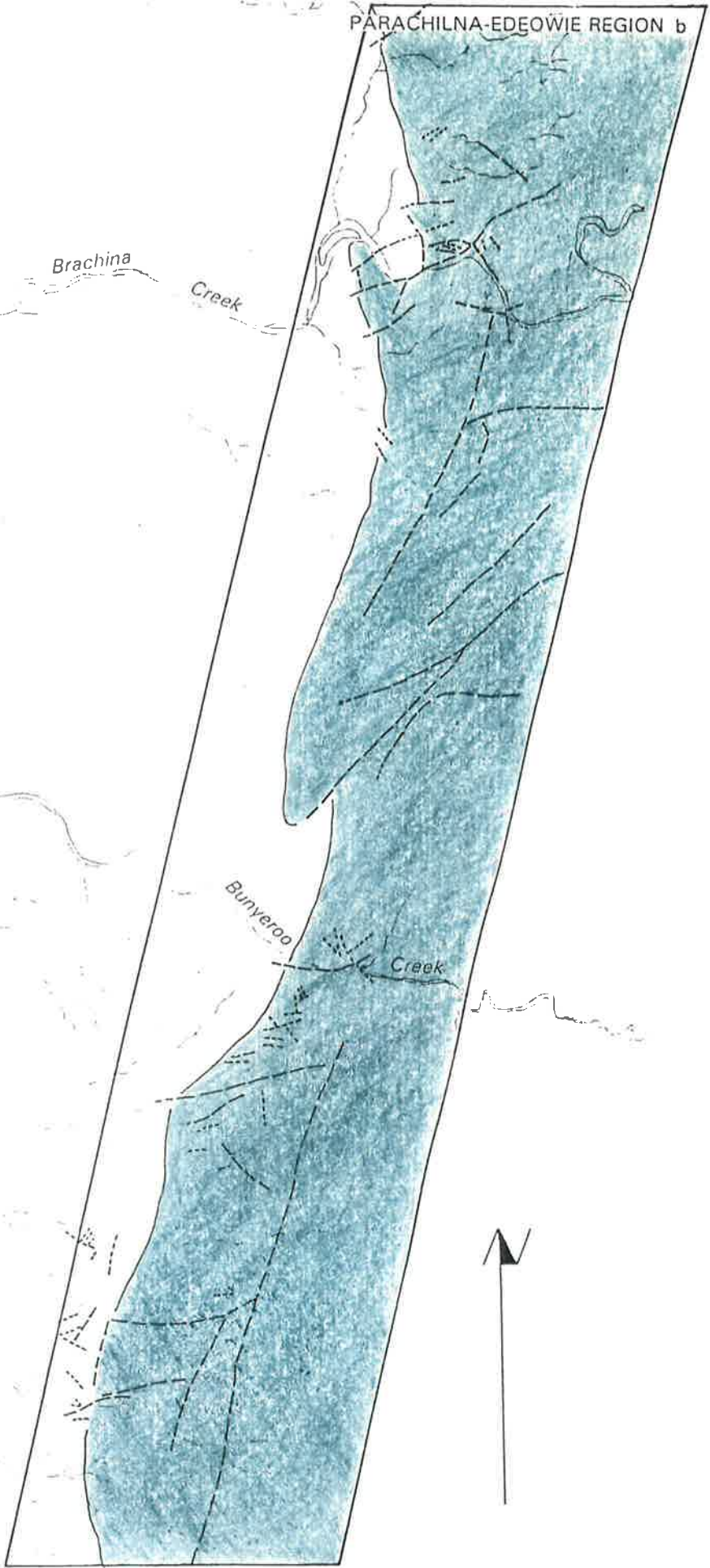




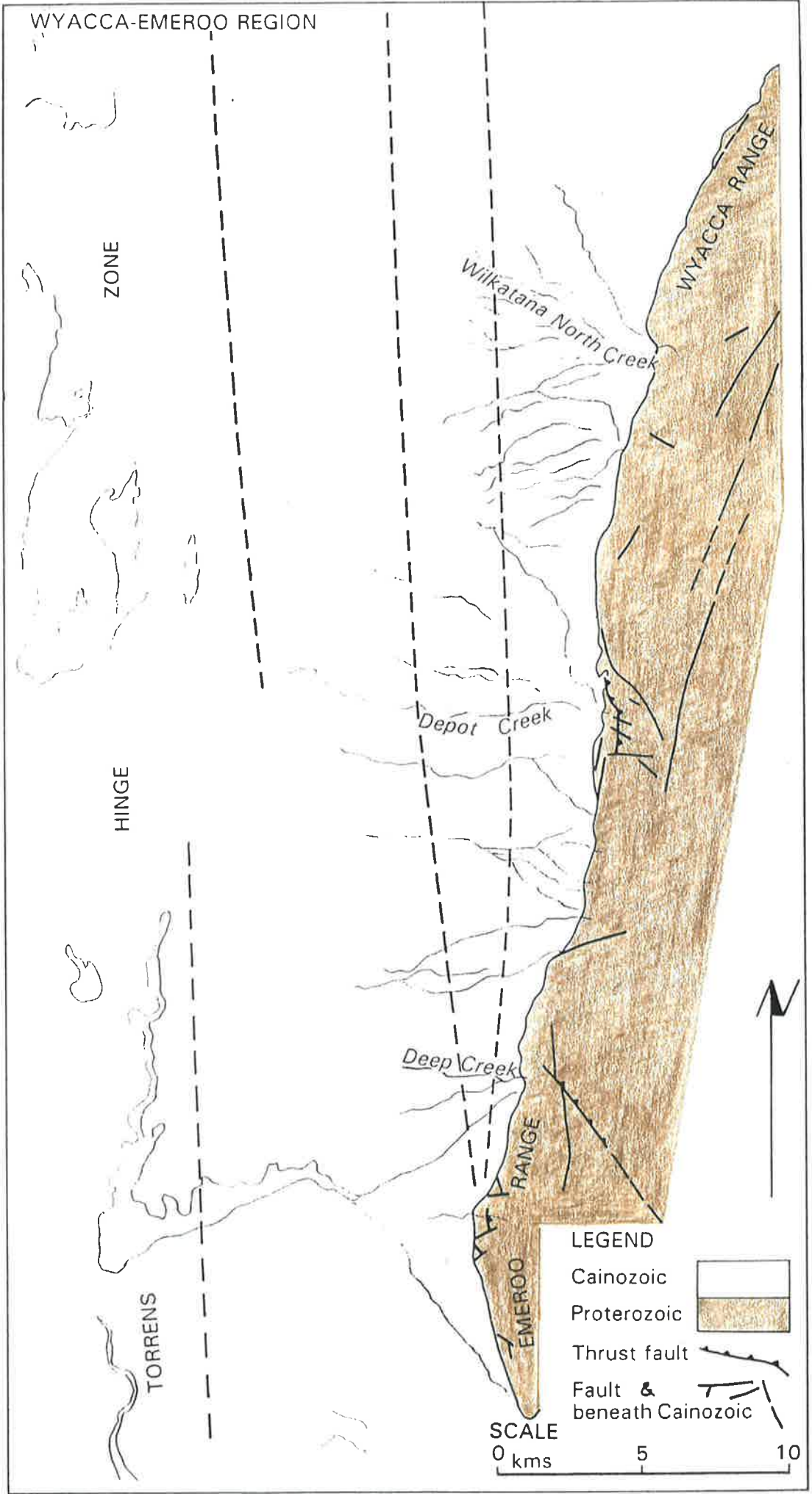
PARACHILNA-EDEOWIE REGION b

Brachina  
Creek





Bunyeroo  
Creek



WYACCA-EMEROO REGION



LEGEND

- Cainozoic 
- Proterozoic 
- Thrust fault 
- Fault & beneath Cainozoic 

SCALE  
0 kms 5 10

Figure 1.7

Thrust fault, Wilkatana North Creek (see also Figure 1.5c) described by Williams (1973)

(a) general view

(b) detail, 53mm camera lens cap for scale.


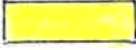






Figure 1.8

Geological sections





(a) Parachilna-Edeowie region: A - B Lake Torrens to mouth of Parachilna Gorge (after Dalgarno & Johnson, 1966; Johns, 1968a; Anonymous, 1982; Vakil, 1983) and C - D Lake Torrens to mouth of Brachina Gorge (after Dalgarno & Johnson, 1966; Johns, 1968a; Anonymous, 1982; Cockshell, 1983)

LEGEND

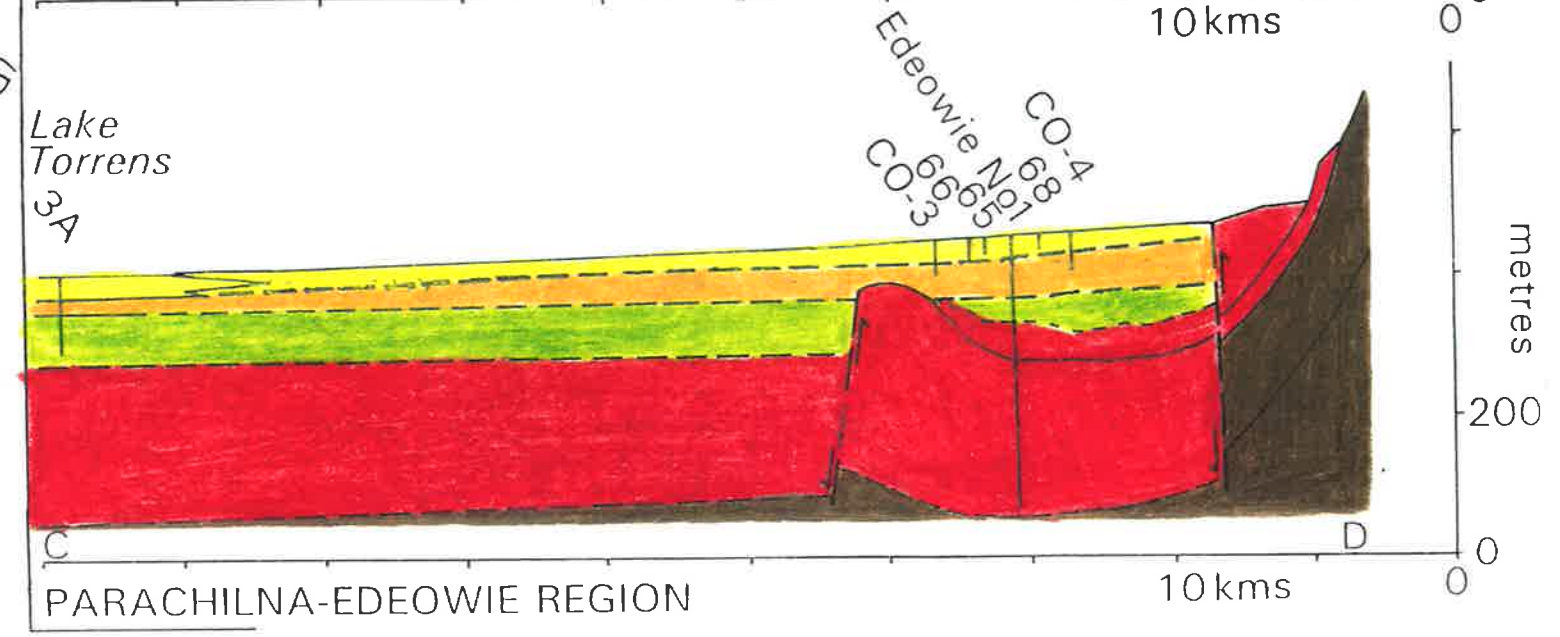
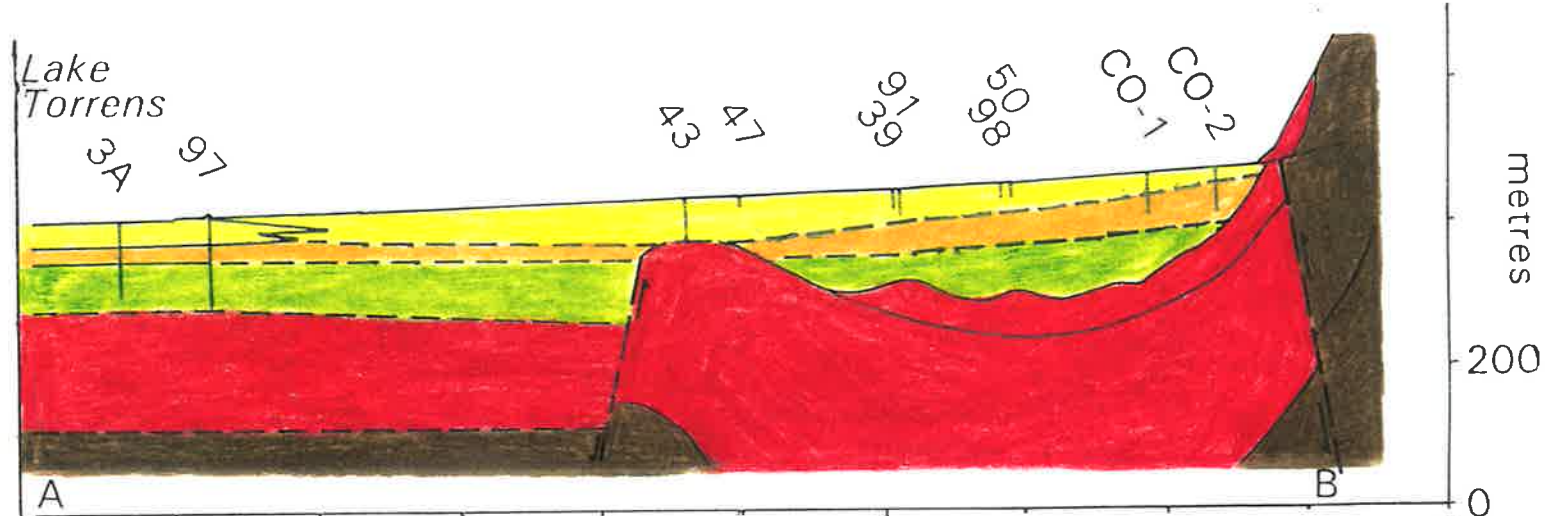
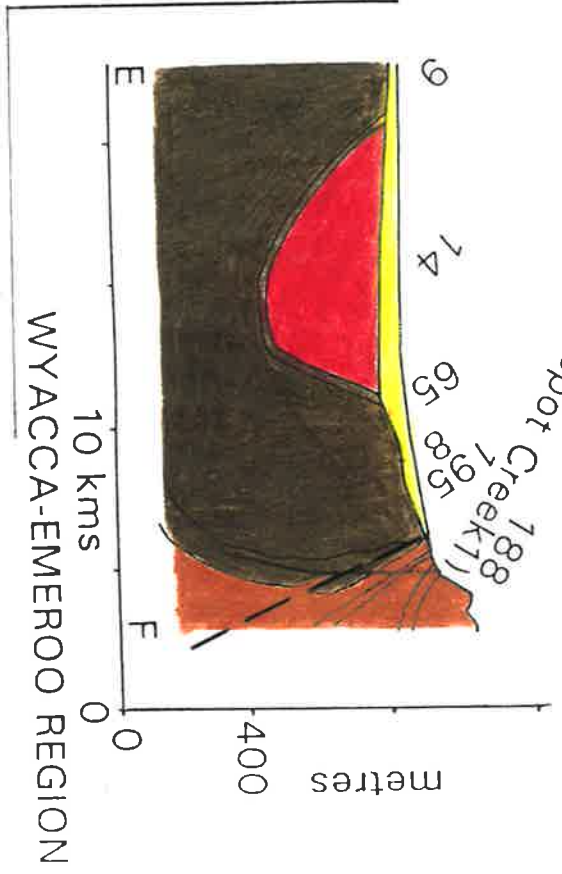
	Quaternary lake bed deposits
	Quaternary alluvial fan deposits
	?Miocene
	Eocene
	Cambrian
	Proterozoic

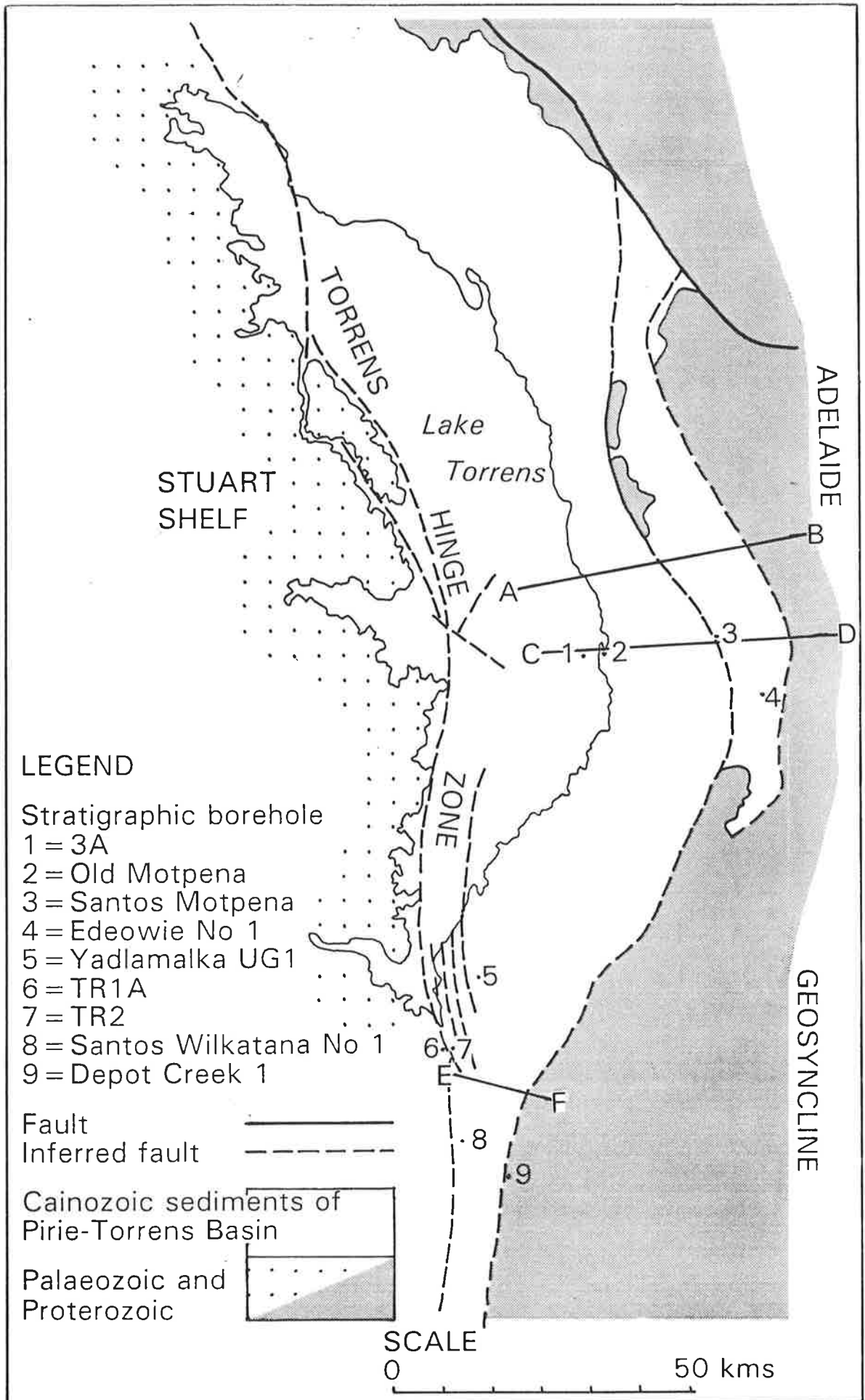
(b) Wyacca-Emeroo region: E - F Torrens Basin west of Wyacca Range (after Johns *et al.*, 1964; Johns, 1968a; Dalgarno *et al.*, 1968)

LEGEND

	Cainozoic
	Cambrian
	Upper Proterozoic
	Lower Proterozoic

(c) Location map for sections (after Coxhead, 1982).

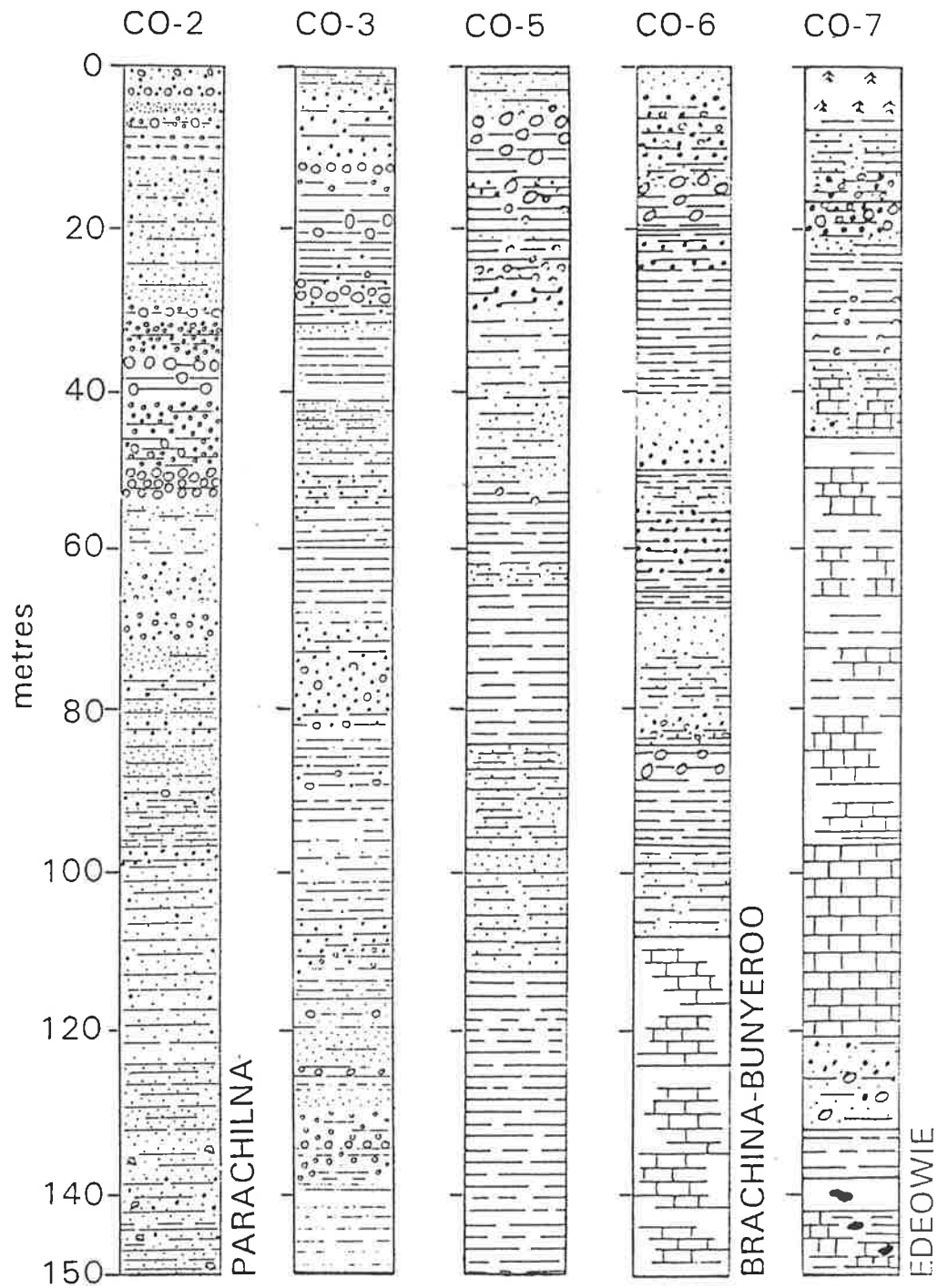






## Figure 1.9

Borelogs of Cainozoic sediments, outer piedmont zone of Parachilna-Edeowie region. CO-2 and CO-6 were drilled within 5 kms of the fanheads of Parachilna and Brachina-Bunyeroo alluvial fans, respectively, CO-3 and CO-5 in the lower parts of the Brachina-Bunyeroo Alluvial Fan, some 9 kms from the fanhead. CO-6 and CO-7 pass through ?Miocene limestone. The Eocene woody coal fragments in CO-7 indicate that the floor of the sub-basin is near (after Anonymous, 1982). See Figure 1.4 for location of bores.



LEGEND

Claystone



Siltstone



Fine sand



Coarse sand



Fine gravel



Coarse gravel & pebbles



Clayey limestone



Limestone



Woody coal chips



Soil: rootlet zone



Shell fragments



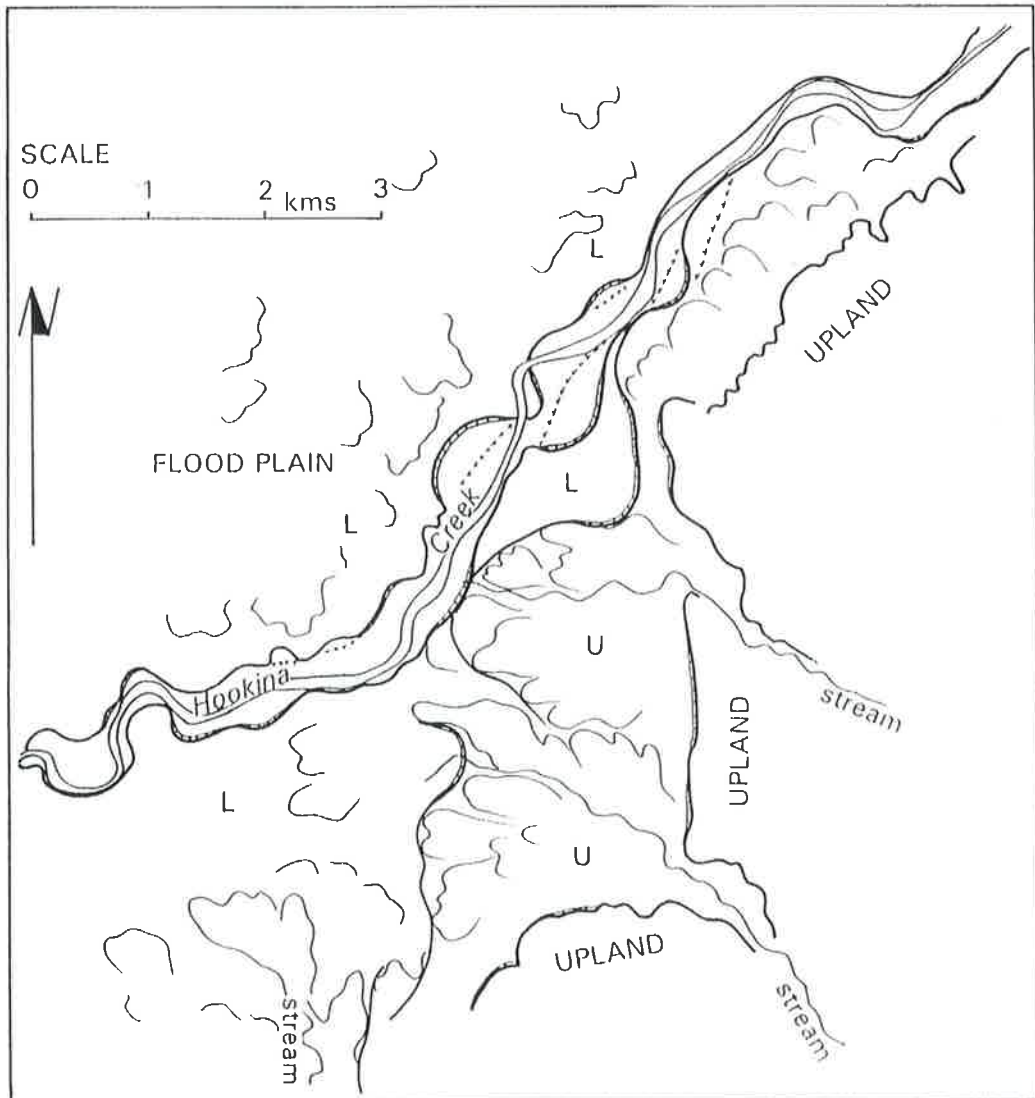
Figure 1.10

Streams incised in channel fill

(a) Brachina Creek has cut down through 6-8 metres of alluvium and to a similar depth in bedrock.

(b) River terraces of Hookina Creek. Upper (U) terraces stand some 10-15 metres higher than the lower (L), which, in turn, are some 5 metres above the present stream bed.

(Drawn from Aerial Photography, Survey 2696/10, 1981, Department of Environment and Natural Resources, South Australia).



## Figure 1.11

Late Pleistocene high sea level events in South Australia, compared with (a) the sea level record for Australia (Chappell & Shackleton, 1986), and (b) the benthic oxygen isotope record from deep sea core V19-30 (Shackleton, 1986). (G) glacial maxima, (I-G) interglacial. (after Drexel & Preiss, 1995, p.228)

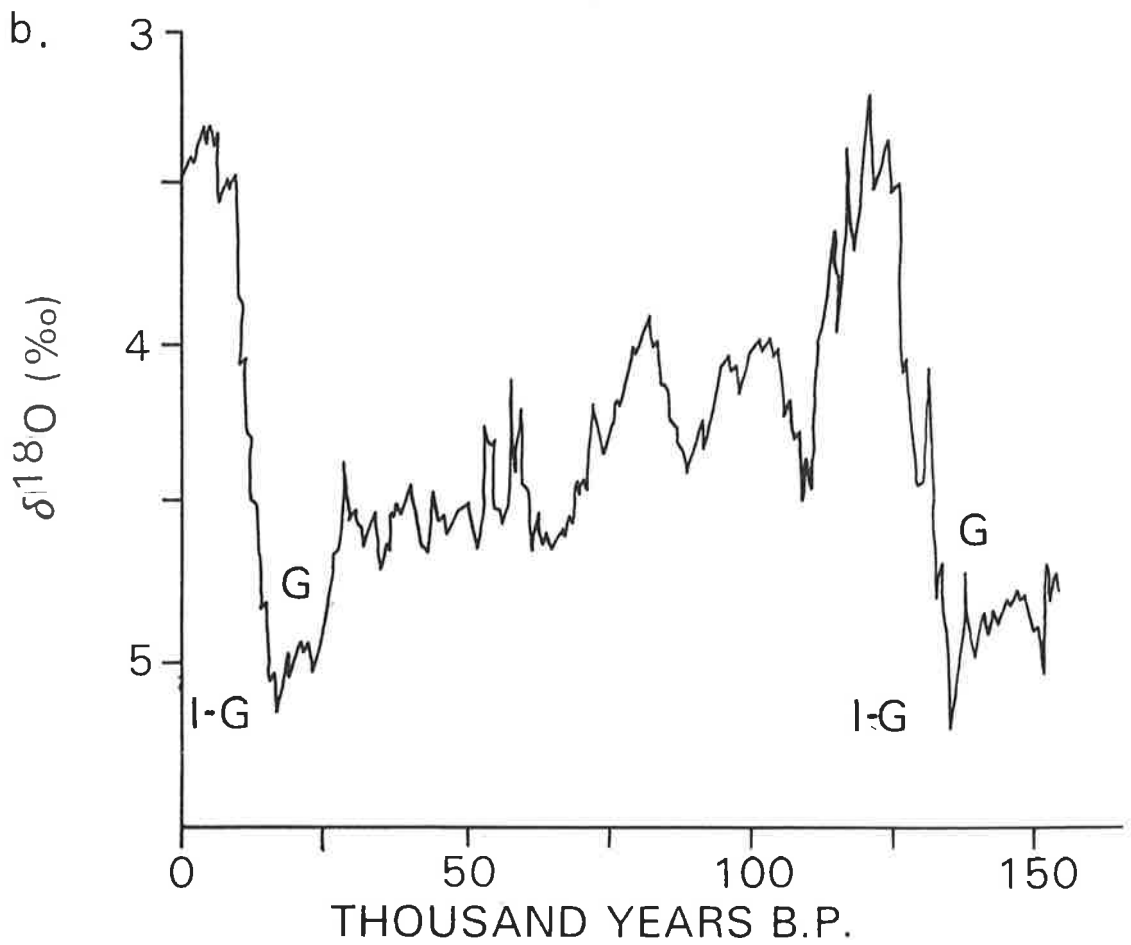
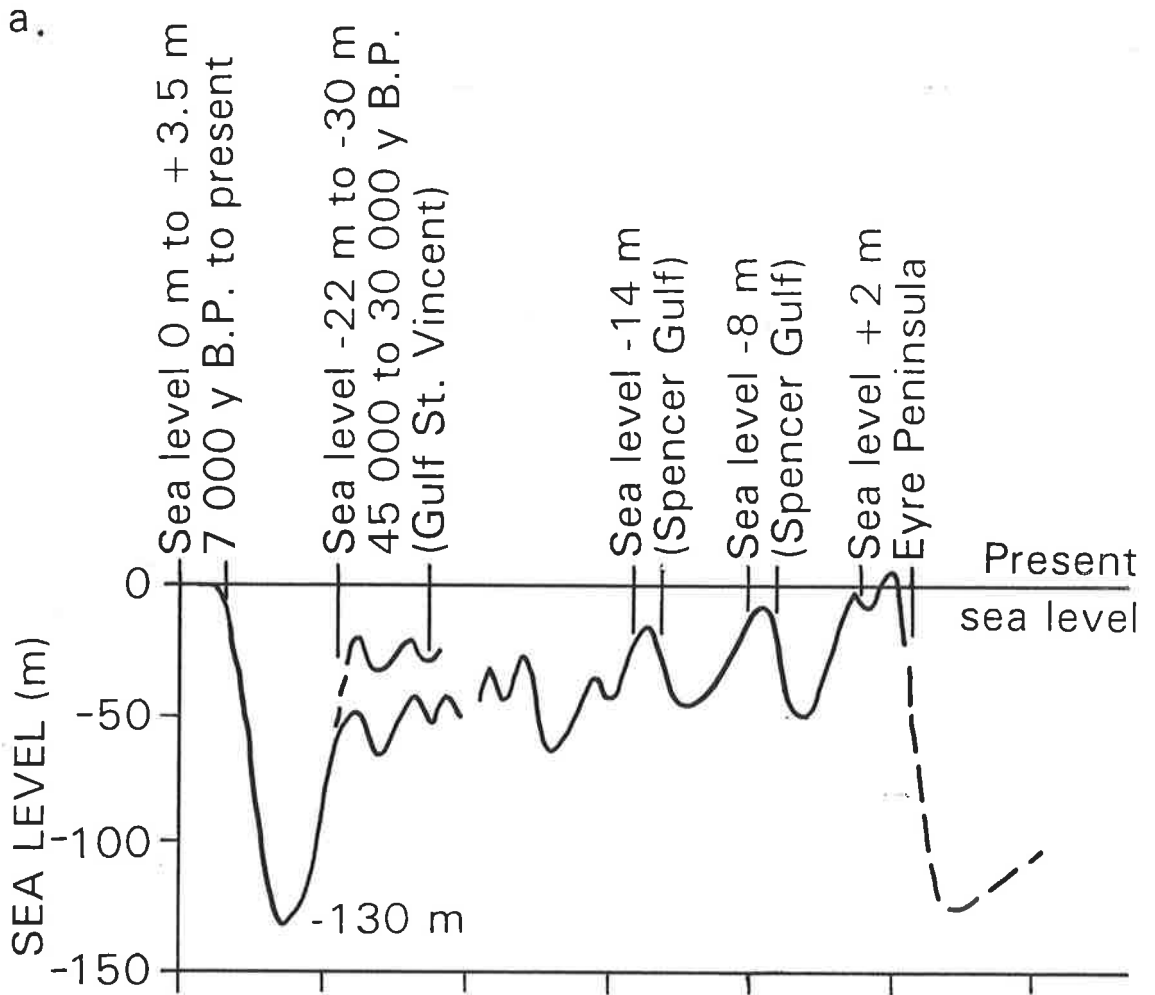


Figure 2.1

(a) Pediments eroded across steeply dipping quartzites, meet the backing upland in an abrupt break of slope, made more angular by a scarp foot depression, which is marked by vegetation, western Cape Fold Belt, southern Africa (C. R. Twidale).

(b) Remarkably smooth, gently sloping pediments in the eastern piedmont of the Front Range, near Boulder, Colorado (C. R. Twidale).

(c) Pediment surface eroded in bedrock meets the sandstone upland in a narrow, concave upwards, zone of curvature, or piedmont angle, in Monument Valley, Utah-Arizona.





### Figure 2.2

The abrupt hill-plain junction is not formed in bedrock and is, therefore, not a piedmont angle: alluvial deposits bury the lower slopes at the base of the upland, Death Valley, U.S.A. View across the fanhead trench eroded by Furnace Creek drainage diverted through Gower Gulch. Covered pediments (left middle ground) of Figure 2.6.

### Figure 2.3

(a) Inselberg landscape in granitic gneiss, where the piedmont angle is a sharp break of slope, or piedmont angle, in Namaqualand, southern Africa (C. R. Twidale).

(b) The piedmont angle develops as a result of moisture concentration, weathering and erosion of the granitic bedrock at the foot of the scarp in Namibia, southern Africa.

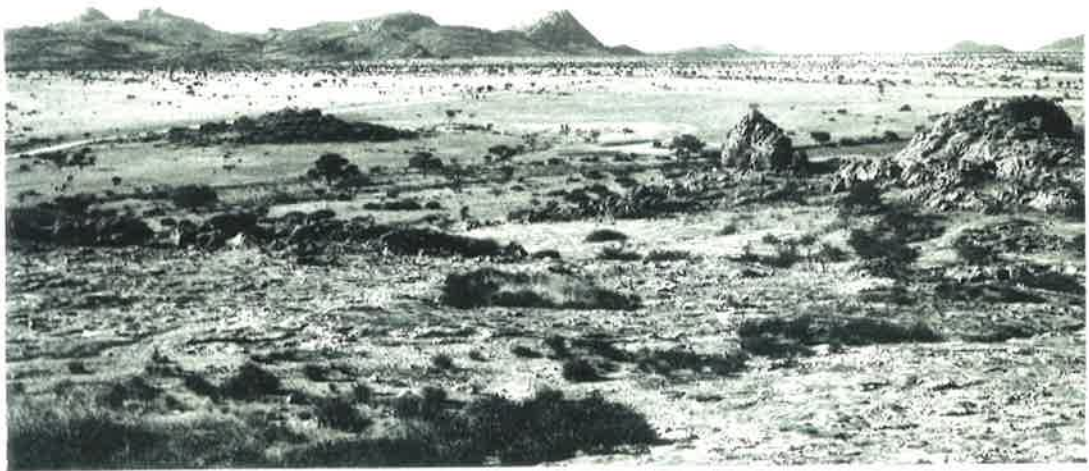
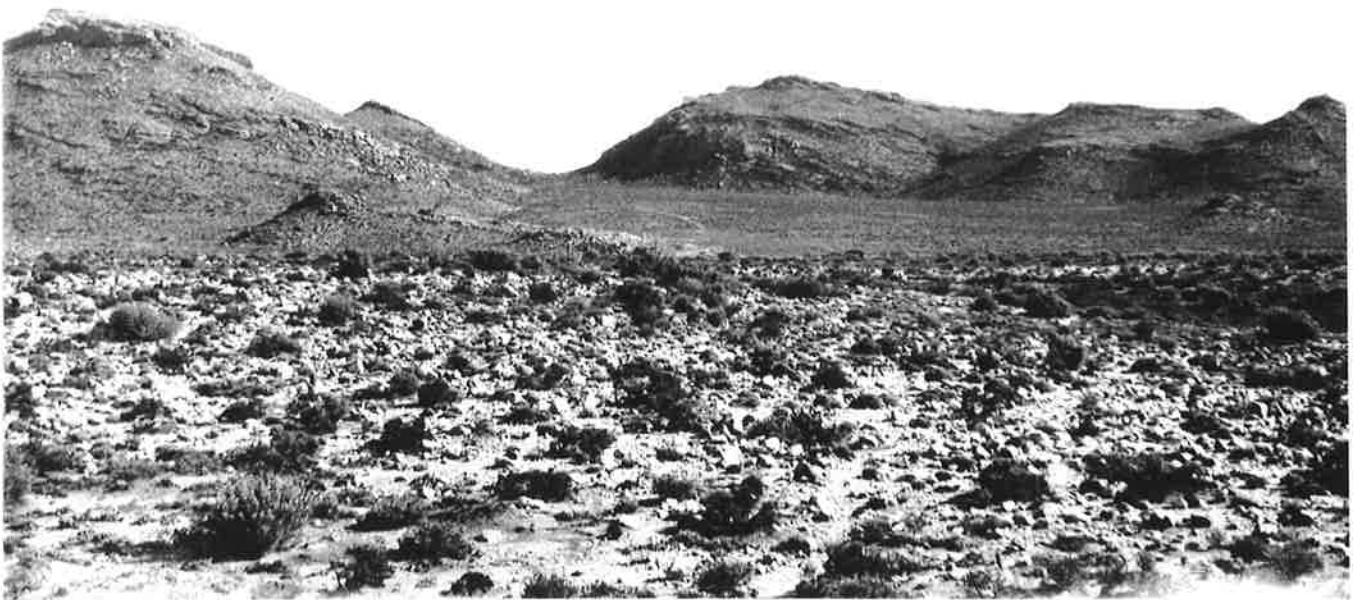


Figure 2.4

- (a) Eroded bedrock floor of Gower Gulch resembles a pediment embayment as Furnace Creek undercuts and trims the sedimentary walls of its valley below Zabriskie Point, Death Valley, U.S.A. (C. R. Twidale).
  
- (b) Pediment pass eroded in gneissic upland in Namaqualand (C. R. Twidale).



### Figure 2.5

Laterally corradating streams have not eroded the pediments surrounding this small, well jointed, granite inselberg, or nubbin at Naraku, in northwestern Queensland.

### Figure 2.6

Pediments, thinly covered with detritus, are eroded across the steeply dipping, sedimentary sequence below Zabriskie Point. They stand higher than the surface of the alluvial fan, in the foreground, deposited at the lower end of Gower Gulch, Death Valley, U.S.A. (C. R. Twidale).

### Figure 2.7

Mantled pediments, eroded in weathered granite, slope gently away from the foot of Ucontitchie Hill, a domed granite inselberg on northwestern Eyre Peninsula, South Australia.



Figure 2.8

Fault scarps disrupt the upper slopes of Badwater alluvial fan at the foot of Black Mountains, Death Valley, U.S.A.

Figure 2.9

Successive flows of deposits are defined by the depth of colour of desert varnish on an alluvial fan in Death Valley, U.S.A.

Figure 2.10

Alluvial fan of sieve deposits, described by Hooke (1967), NNE of Badwater in Death Valley, U.S.A.





Figure 3.1 (MAP POCKET)

Morphology map: Parachilna-Edeowie region.

(base map: Aerial Photography, Surveys 2501 & 2502, 1979, Department of Environment and Natural Resources, South Australia).

Figure 3.2 (MAP POCKET)

Morphology map: Wyacca-Emeroo region.

(base map: Aerial Photography, Survey 4304, 4316, 1991, Department of Environment and Natural Resources, South Australia).

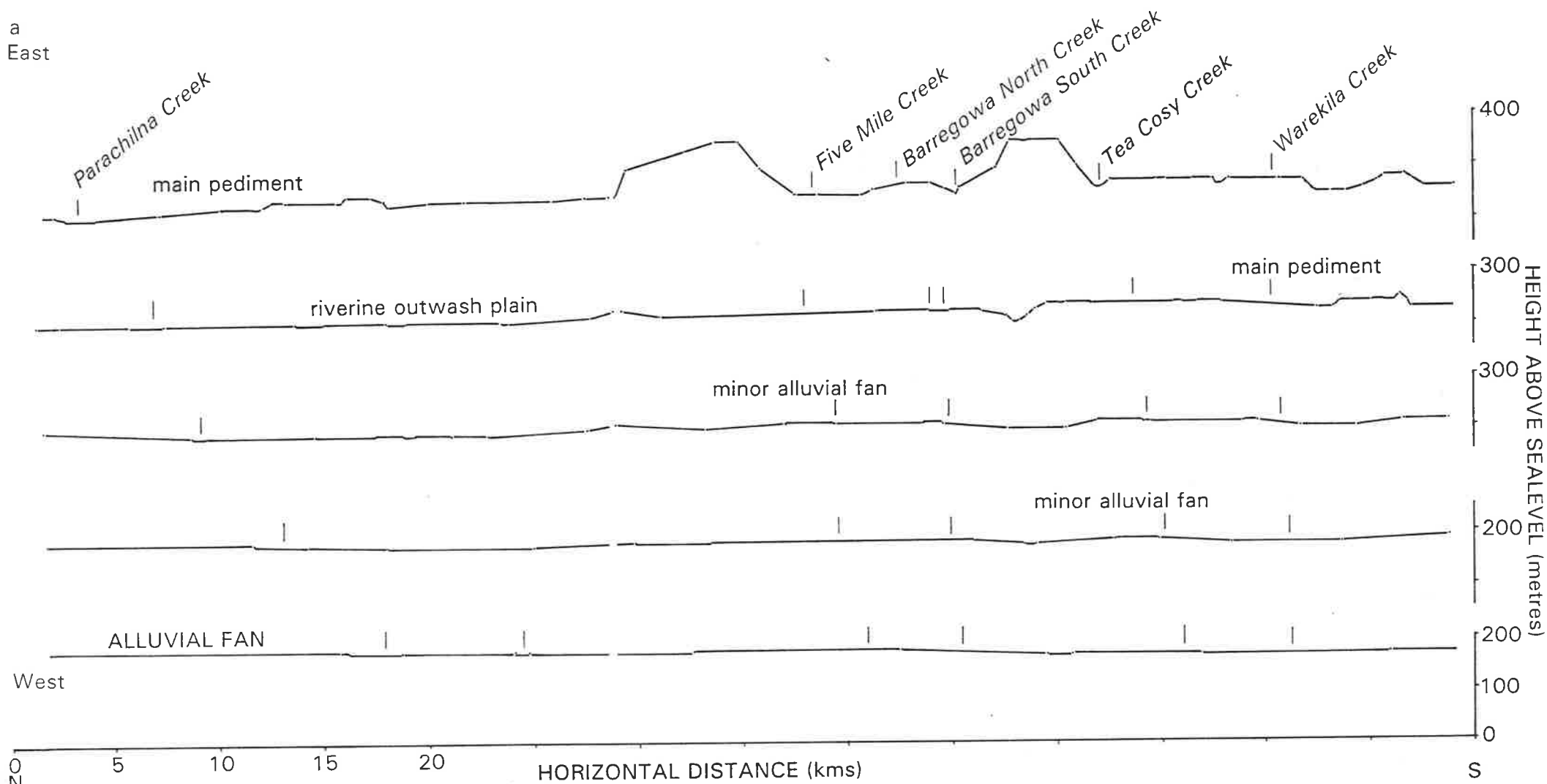
### Figure 3.3

Transverse profiles of inner piedmont zone: Parachilna-Edeowie region.

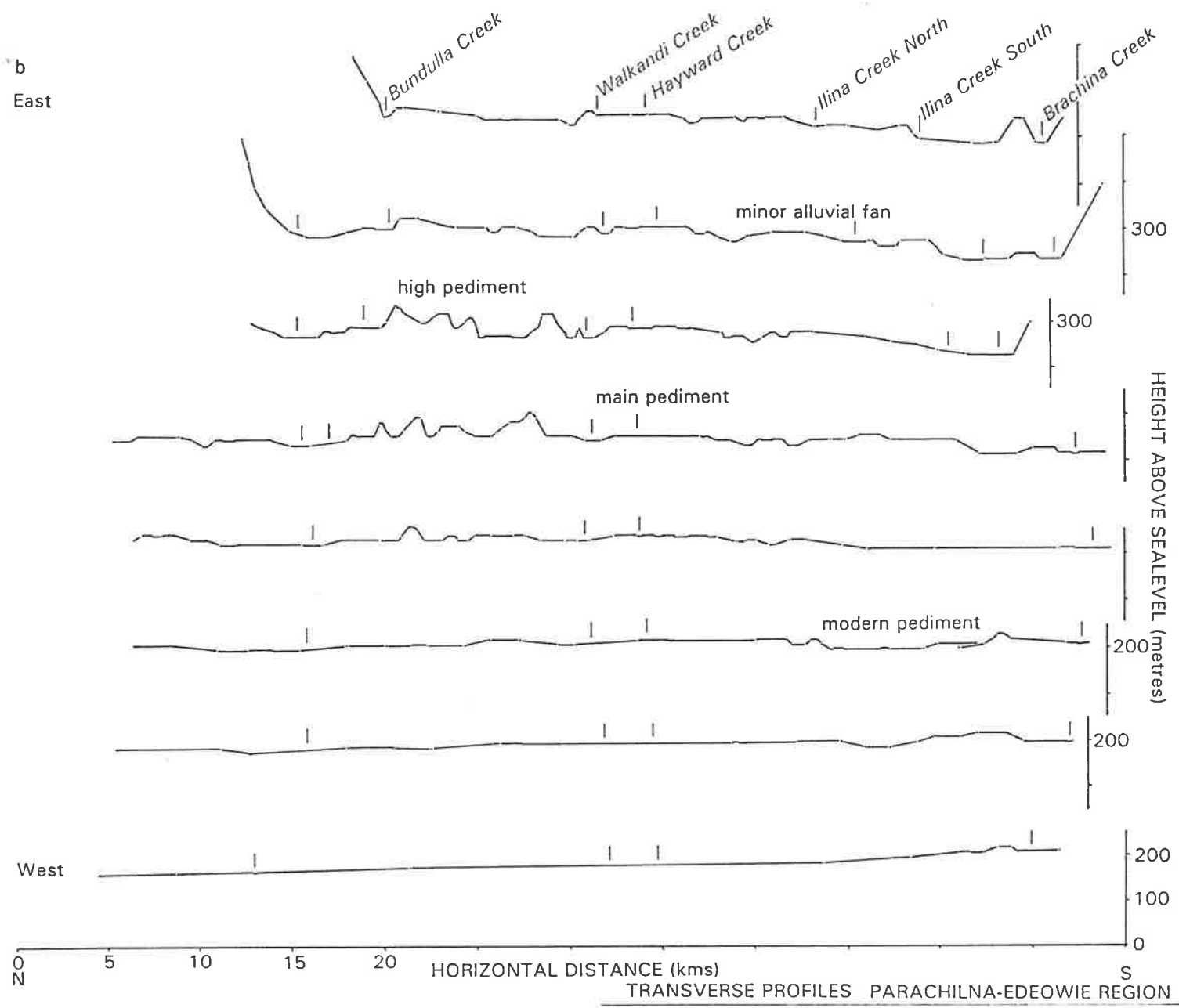
- (a) Sector between Parachilna and Warekila creeks
- (b) Sector between Bundulla and Brachina creeks
- (c) Location of profiles indicated on accompanying map.

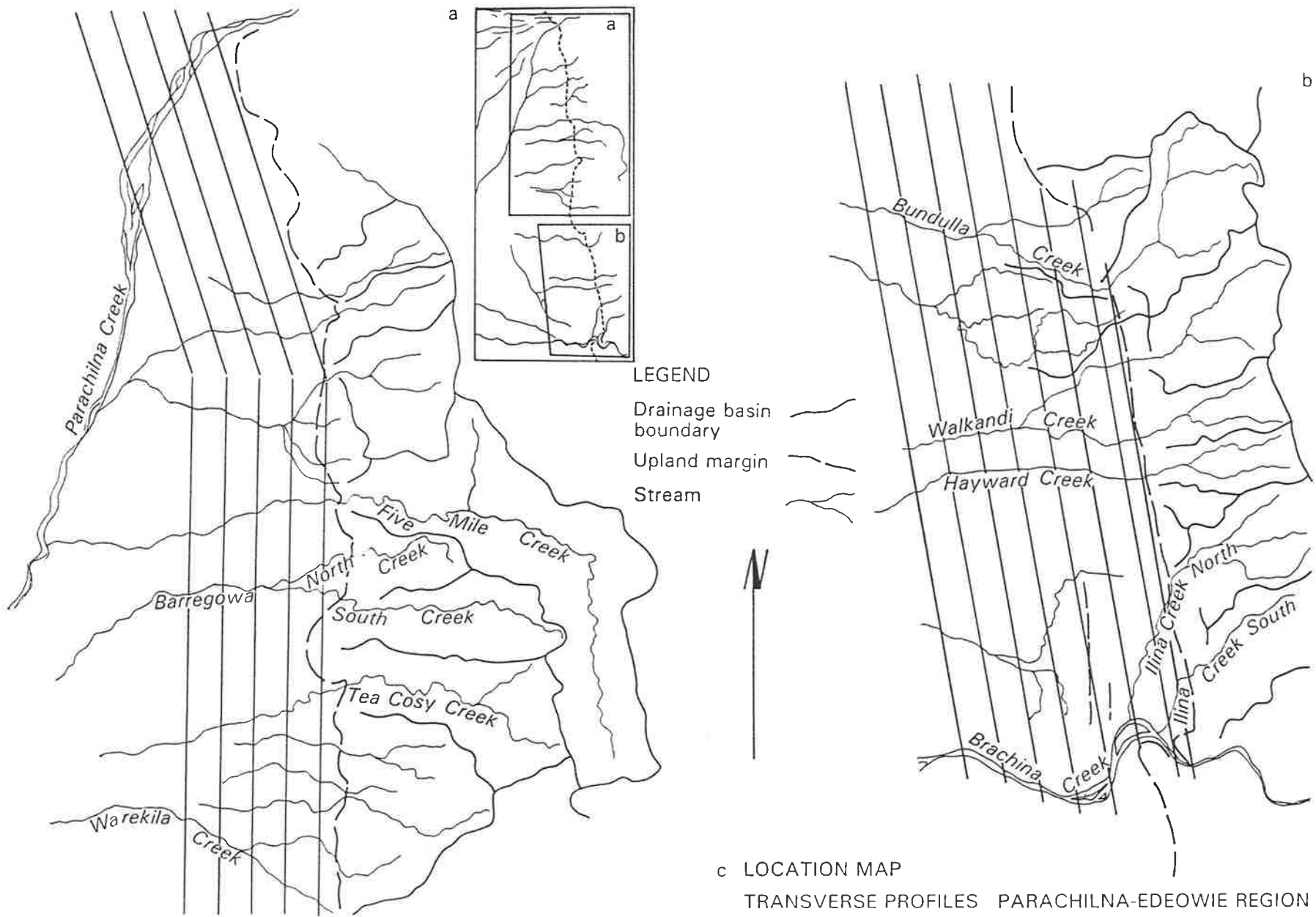
Source: 1:50 000 Topographic Series, map sheets 6535-1 *Parachilna*, 6535-2 *Edeowie*, 6635-3 *Oraparinna*, 6635-4 *Blinman*, Department of Environment and Natural Resources, South Australia.

a  
East



TRANSVERSE PROFILES PARACHILNA-EDEOWIE REGION





c LOCATION MAP  
 TRANSVERSE PROFILES PARACHILNA-EDEOWIE REGION

Figure 3.4

Stages in development of scarp foot valley and exaggeration of pediment fan form, in plan view and cross section.

# DEVELOPMENT OF SCARP FOOT VALLEY & EXAGGERATION OF PEDIMENT FAN SHAPE

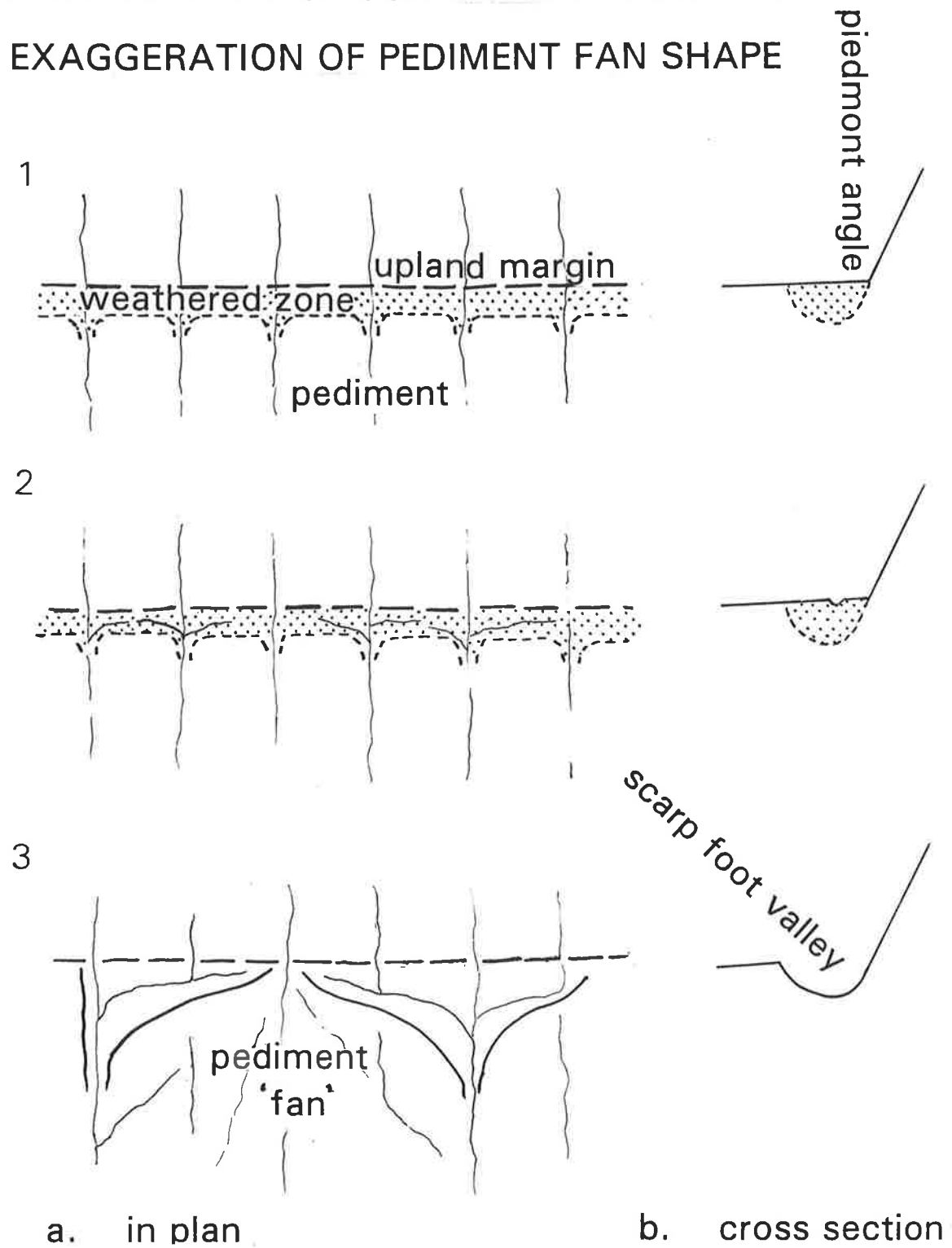




Figure 3.5

Scarp foot valley eroded by tributaries of Walkandi Creek.

Figure 3.6

The piedmont angle is coincident with a lithological boundary.

(a) The smooth gentle slope of the Hayward Pediment meets the upland in an abrupt break of slope, or piedmont angle.



## Figure 3.6

The piedmont angle is coincident with a lithological boundary.

(b) Oblique aerial view of the inner piedmont zone north of Brachina Creek. To the right the main pediment surface associated with Hayward Creek (a). Former hill-plain junctions marked by weathered bedrock and breaks of slope on the scarp face are related to the high pediment surface (left), remnants of which stand above the level of the main pediment.

(c) Piedmont angle advances downdip in Parachilna-Edeowie region (after Twidale, 1972).

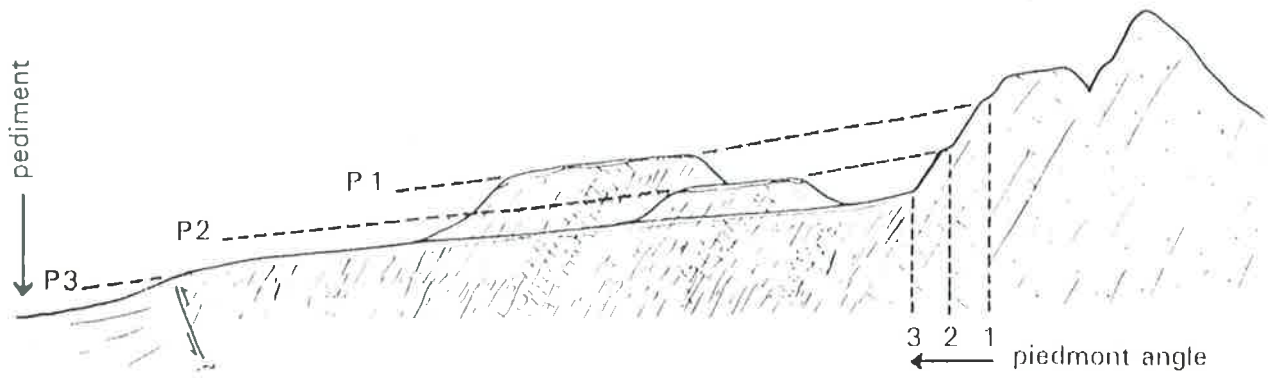


Figure 3.7

Bevelled limestone ridge and the main pediment surface

(a) View south across Bunyeroo Creek into the scarp foot valley. The projected level of the covered pediment surface (note the steeply dipping bedrock in the side of the mesa) on the right is coincident with the bevelled surface of the limestone ridge.

(b) Oblique aerial view of (a).

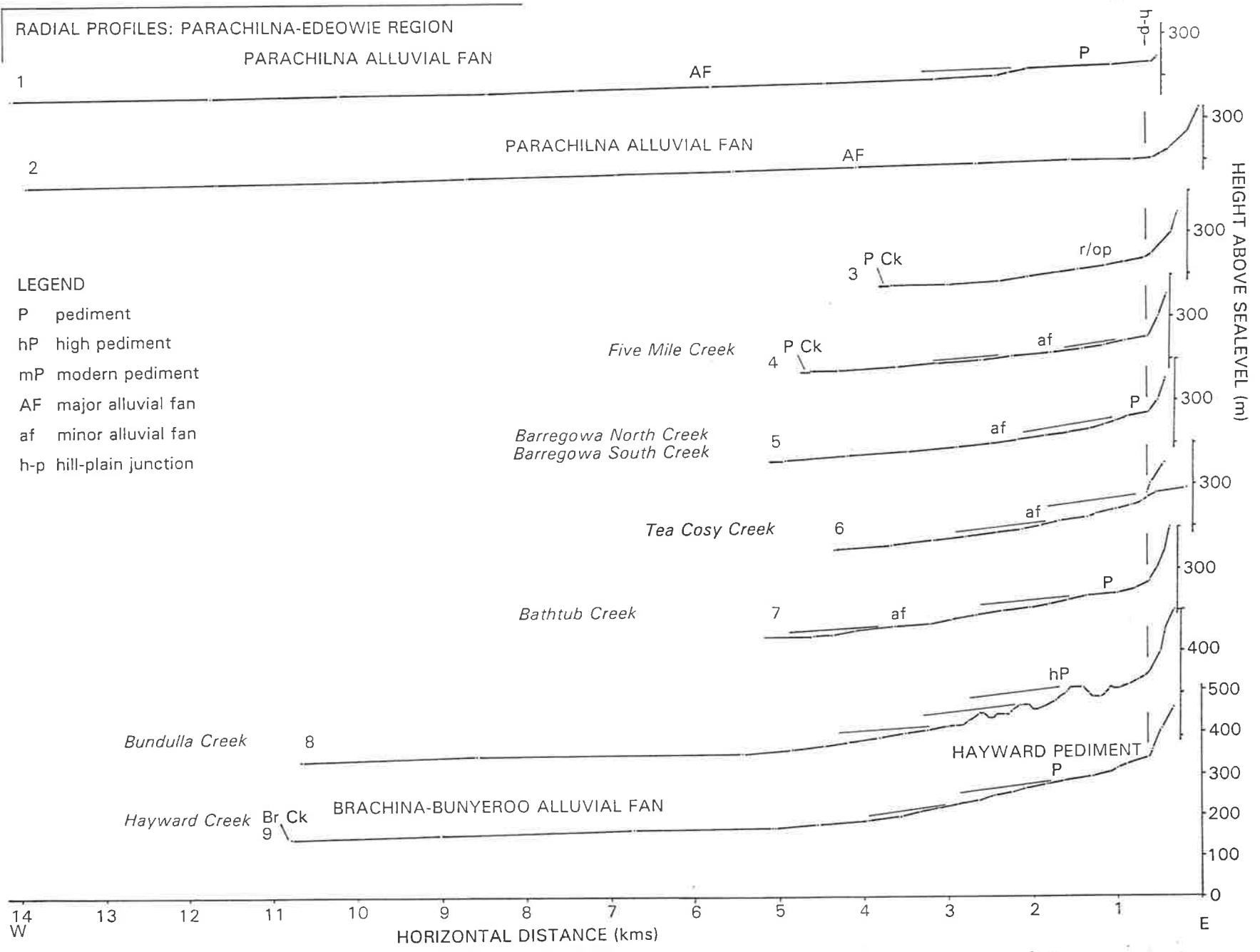


Figure 3.8

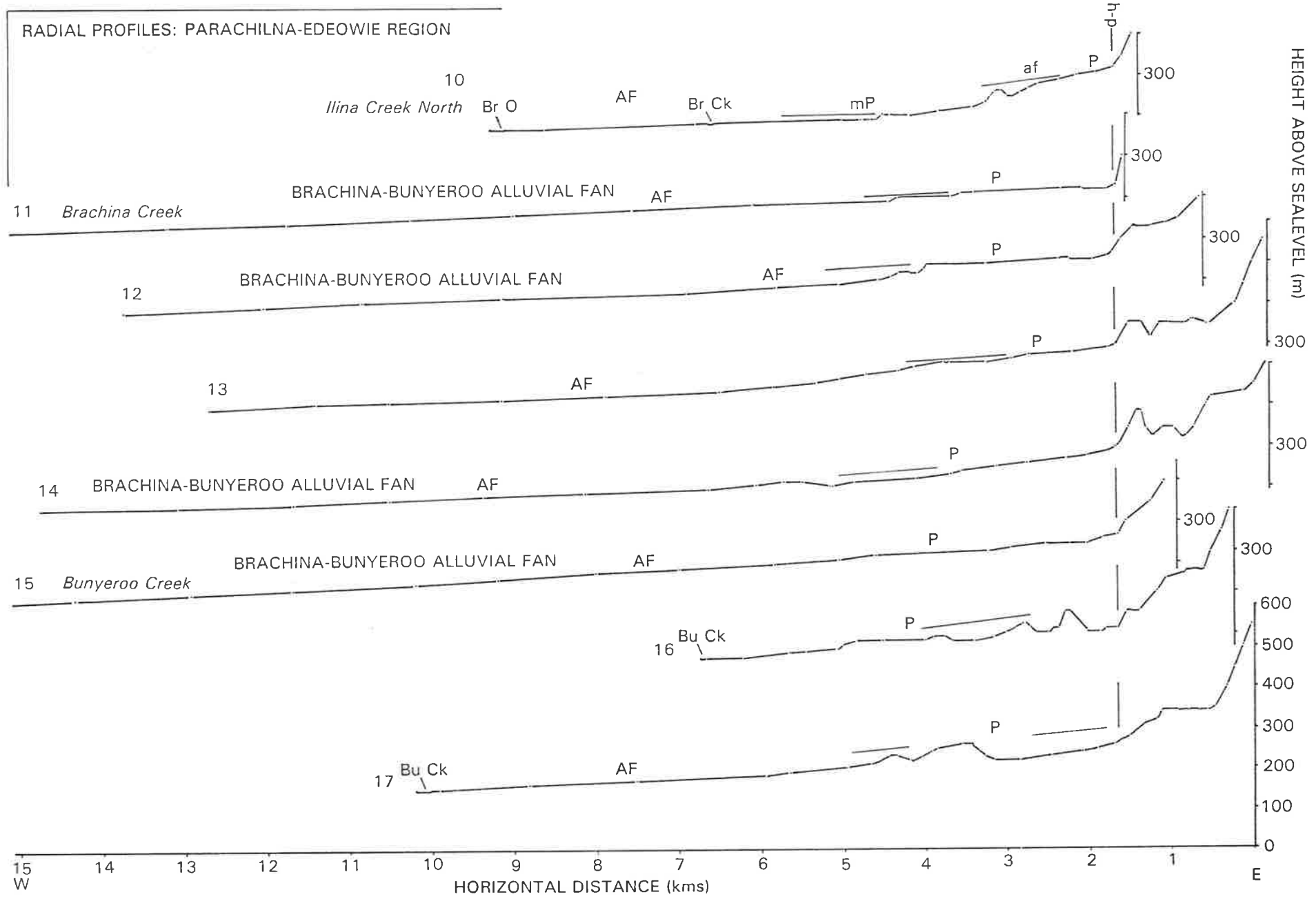
(a) Radial profiles (1-20) of the piedmont: Parachilna-Edeowie region. Parachilna Creek (P Ck), Brachina Creek (Br Ck), Brachina Overflow (Br O).

(b) Location of profiles indicated on accompanying map.

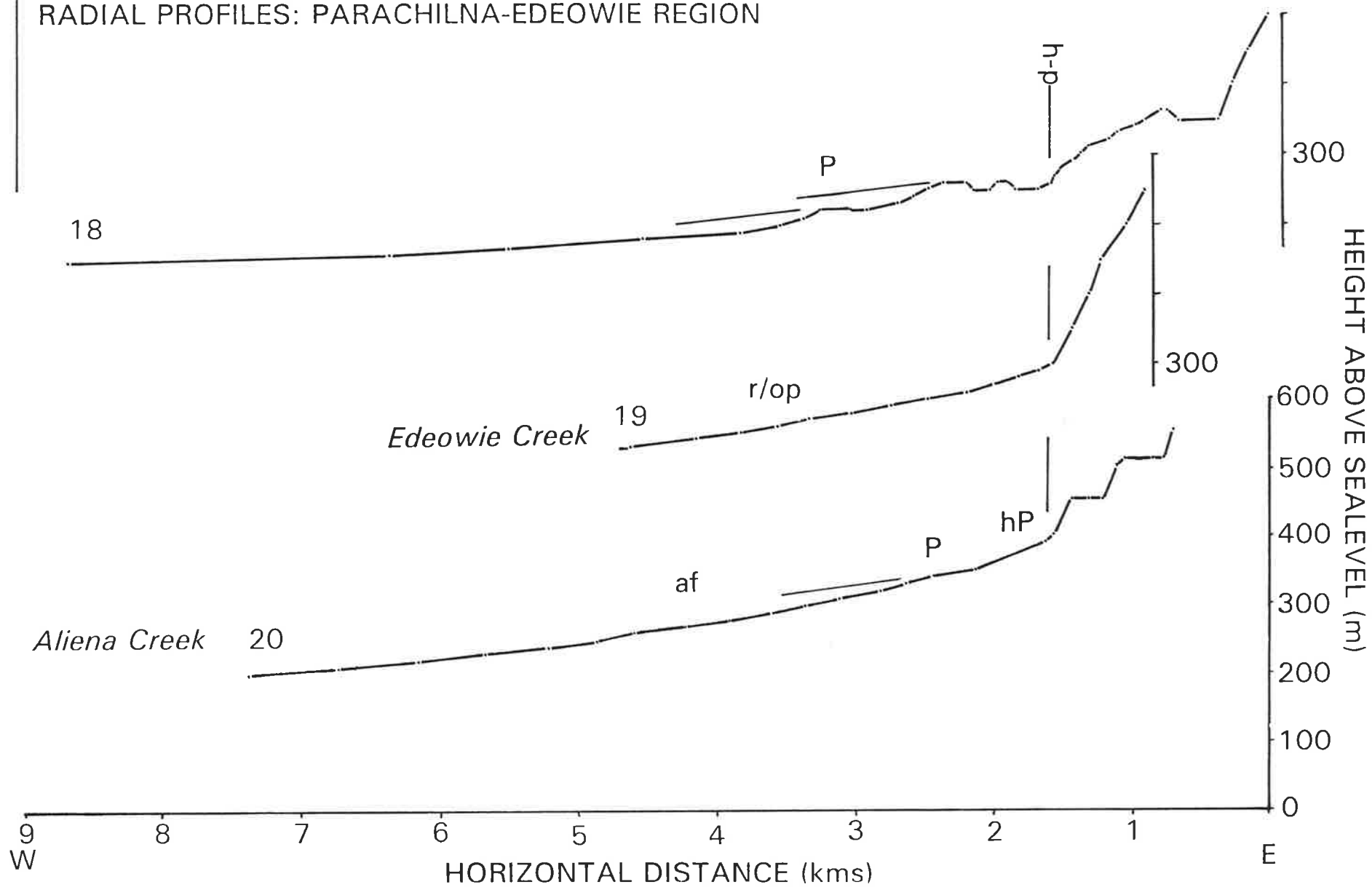
Source: 1:50 000 Topographic Series, map sheets 6535-1 *Parachilna*, 6535-2 *Edeowie*, 6635-3 *Oraparinna*, 6635-4 *Blinman*, Department of Environment and Natural Resources, South Australia.







RADIAL PROFILES: PARACHILNA-EDEOWIE REGION



RADIALS: PARACHILNA-EDEOWIE REGION

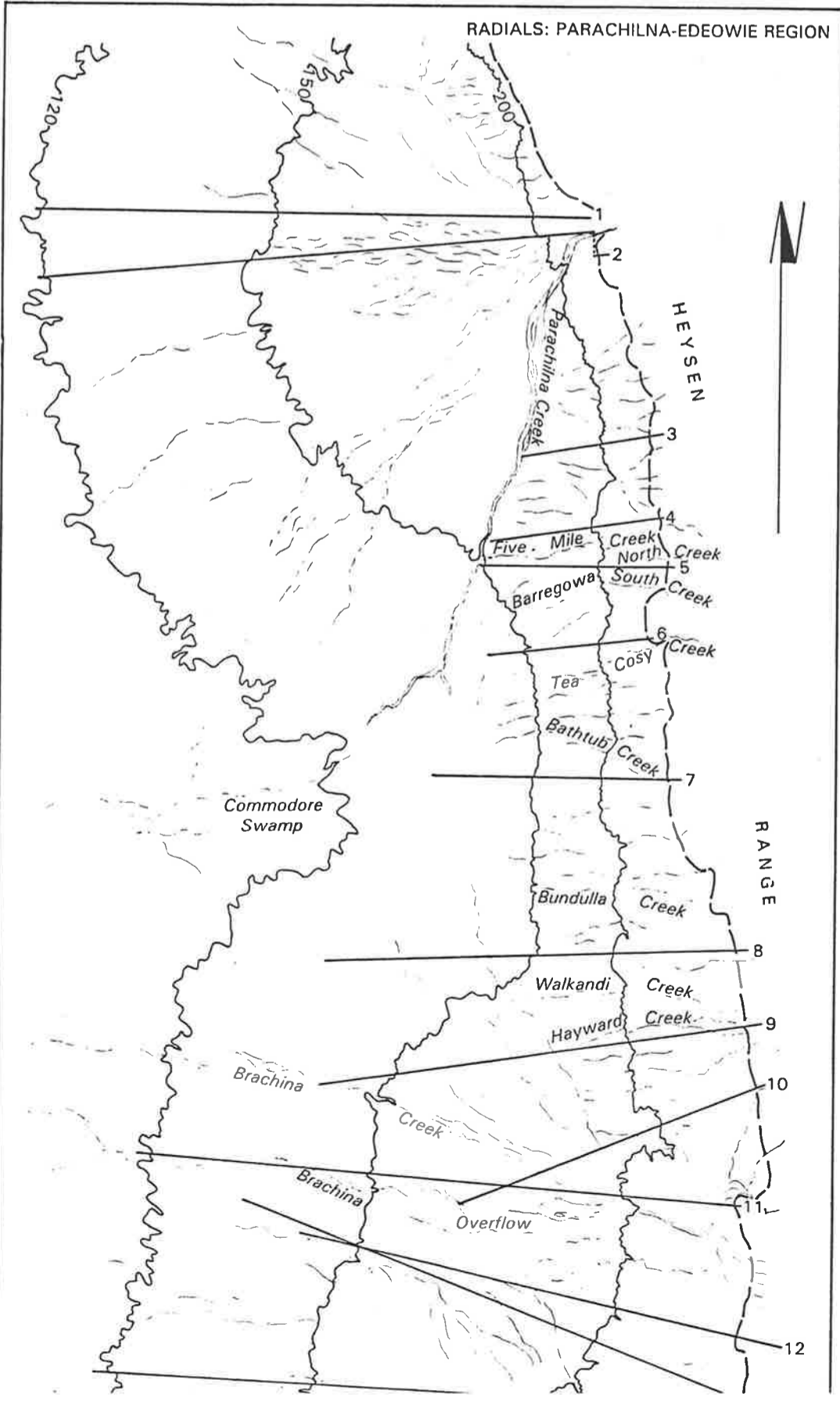


Figure 3.9

(a) Alluvium fills the irregularities of the eroded bedrock surface and contributes to the smooth appearance of the covered pediment adjacent to Bunyeroo Creek.

(b) Bevelled bedrock surface beneath the alluvial cover in a pediment remnant adjacent to Ilina Creek North.



Figure 3.10

Maps of main pediment surface associated with Hayward Creek

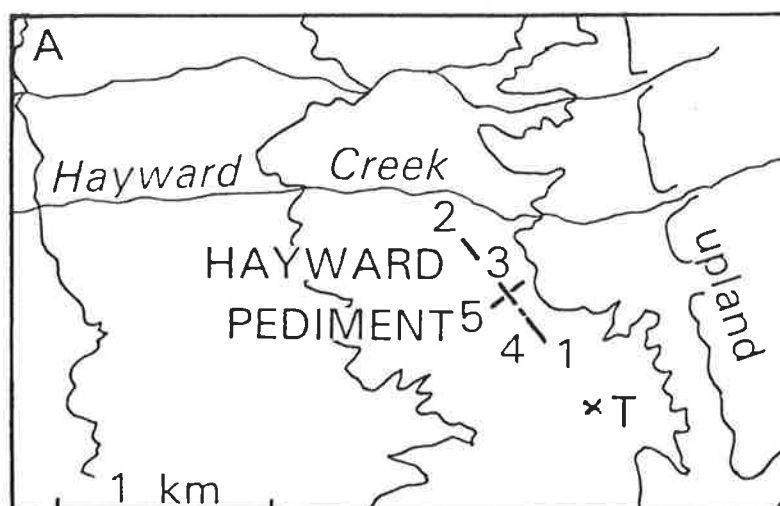
(a) Topography. Inset map (below) shows location of shallow seismic refraction survey lines 1-5 and the test site (T) - see Appendix II. Source: 1:50 000 Topographic Series, map sheets 6535-2 *Edeowie*, 6635-3 *Oraparinna*, Department of Environment and Natural Resources, South Australia.

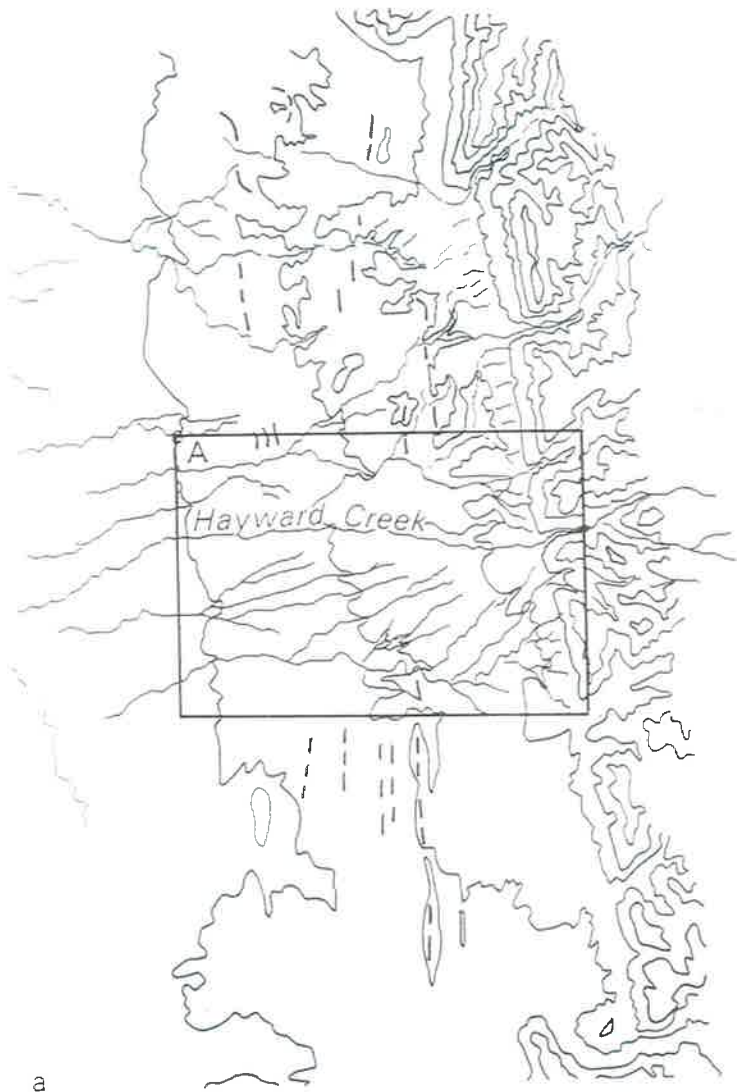
(b) Geology (Dalgarno & Johnson, 1966).

LEGEND

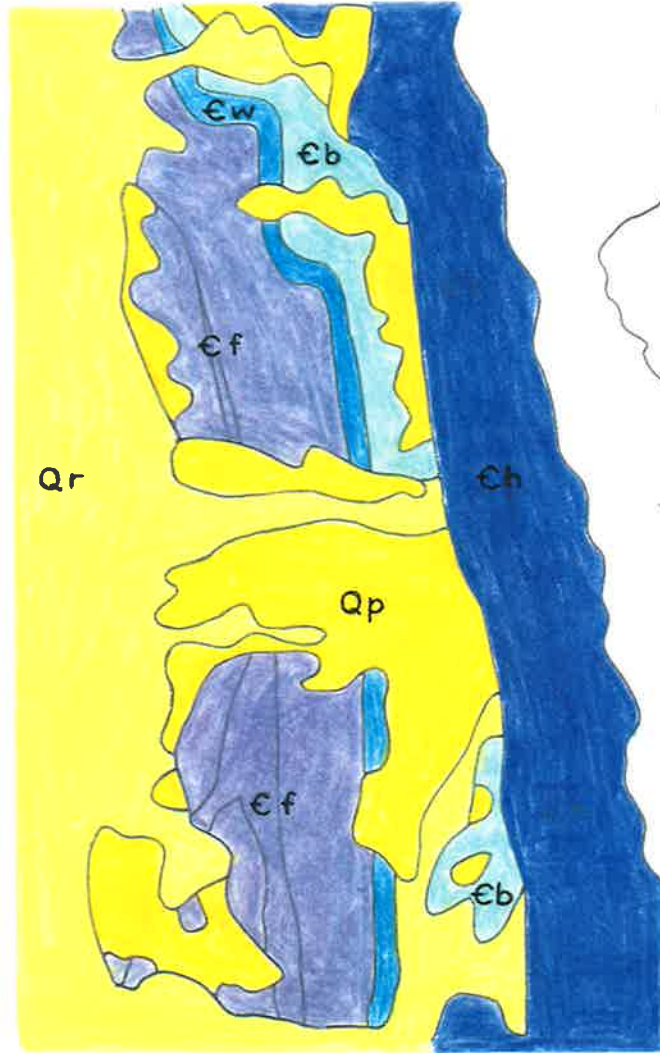
- Qr Quaternary alluvial and slope deposits
- Qp Quaternary piedmont gravels
- Ɔf Middle Cambrian sandstone & siltstone
- Ɔw Middle Cambrian shale/limestone
- Ɔb Middle Cambrian shales
- Ɔh Lower Cambrian massive limestone (Wilkawillina Limestone)

(c) Morphology : main pediment (P), dissected (dP), Bundulla-Walkandi high pediment remnants (hP), minor alluvial fans (af), exposures of alluvial pediment cover-bedrock contact (x) in the vicinity of Hayward Pediment, upland margin (short dashed line) and line of strike (base map: Aerial Photography, Survey 2501/031, 1979, Department of Environment and Natural Resources, South Australia).

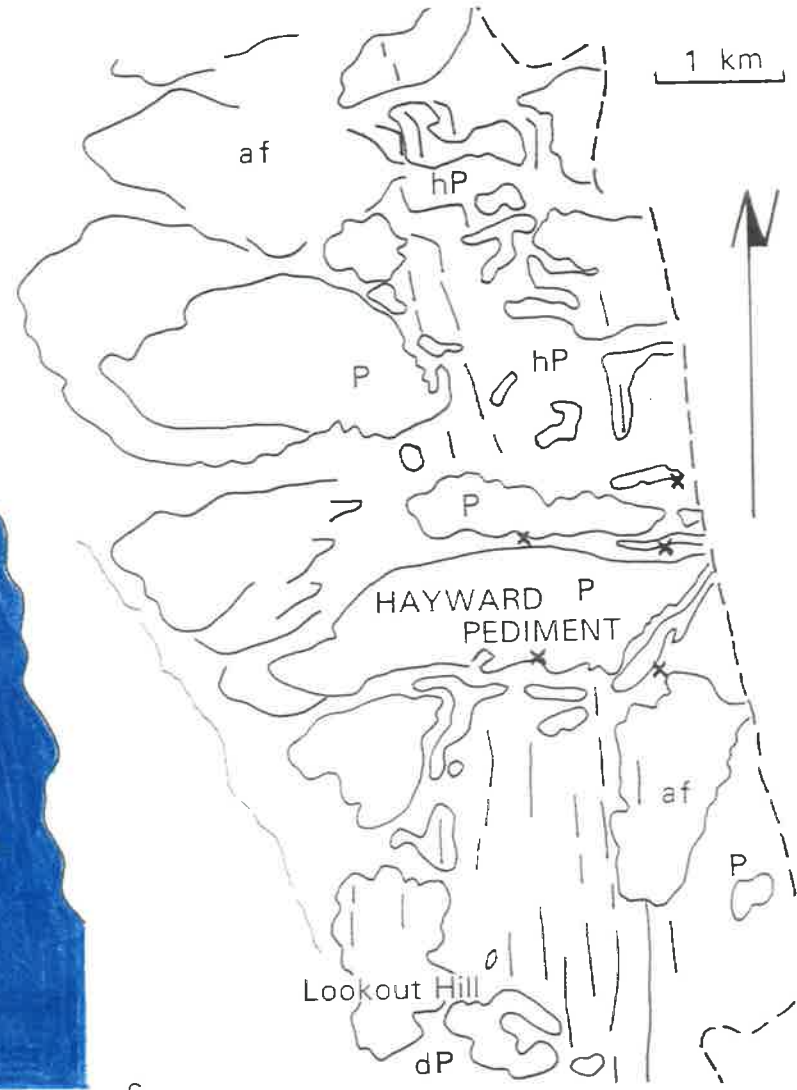




a



b



c

Figure 3.11

- (a) About 2 metres of alluvial detritus derived from the upland covers a bedrock surface cut across steeply dipping siltstones, seen in the channel of a minor stream incised in the main pediment north of Brachina Creek. Hammer 30cm long.
  
- (b) The calibre and type of rock in the bedload of Brachina Creek compares well to that of the pediment cover.
  
- (c) Palaeodrainage line on the Edeowie pediment surface is marked by coarse debris (horizon), similar in all respects to the bedload of Black Oak Creek (foreground).



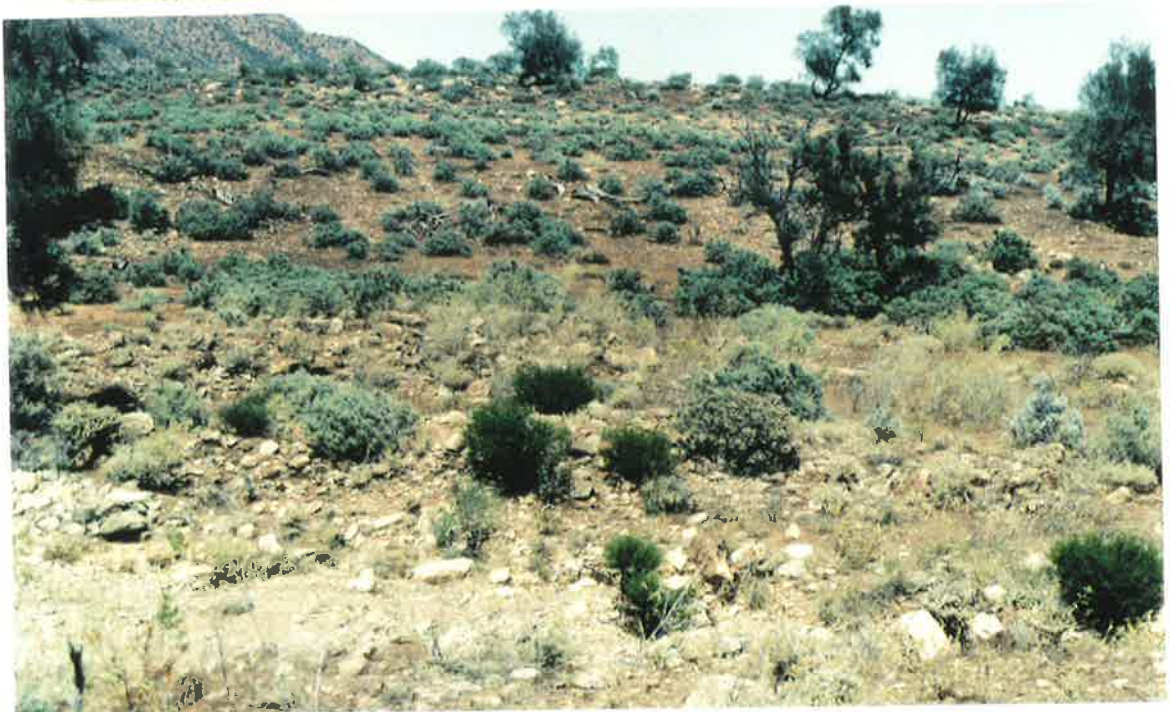


Figure 3.12

Rock type of typical boulders of pediment cover and the weathering of same.

- (a) Sandstone boulder planed off flush with level of surrounding pediment surface. Hammer 30cm long.
- (b) Rounded quartzite boulder split into angular fragments. Hammer 30cm long.
- (c) Typical pediment cover of subangular sandstone and quartzite rocks in a matrix of gravels and fines. Hammer 30cm long.



Figure 3.13

The alluvial cover appears to be about 2 metres thick when viewed along the southern margin of the Ralston 'Pediment', near Boulder, Colorado, U.S.A. However, the thickness of the alluvium, exposed in the road cutting, increases away from the stream from 2 metres to at least 15 metres (right to left). (C. R. Twidale).

Figure 3.14

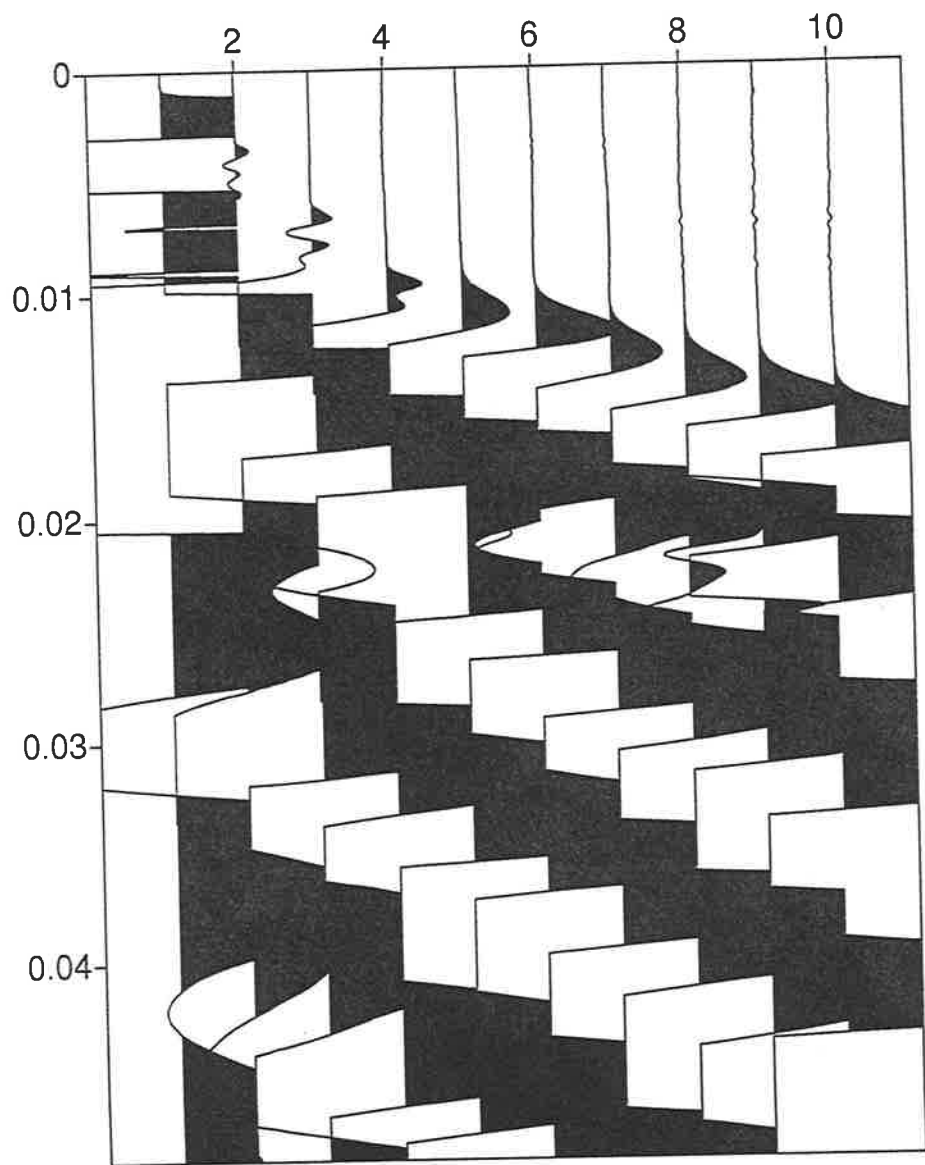
Shallow seismic refraction survey team setting up on the main pediment surface associated with Hayward Creek.



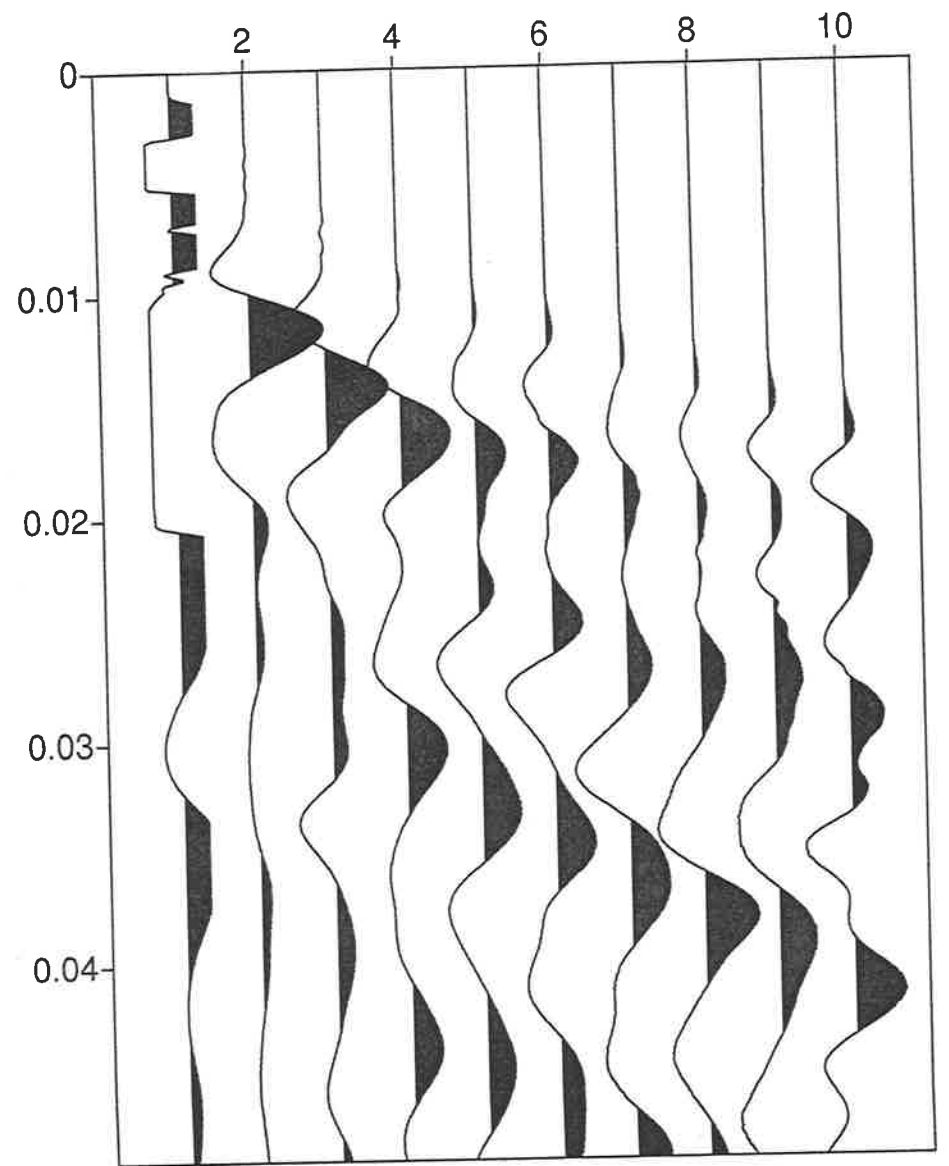
Figure 3.15

Computer printout samples of shallow seismic refraction survey of Hayward Pediment.

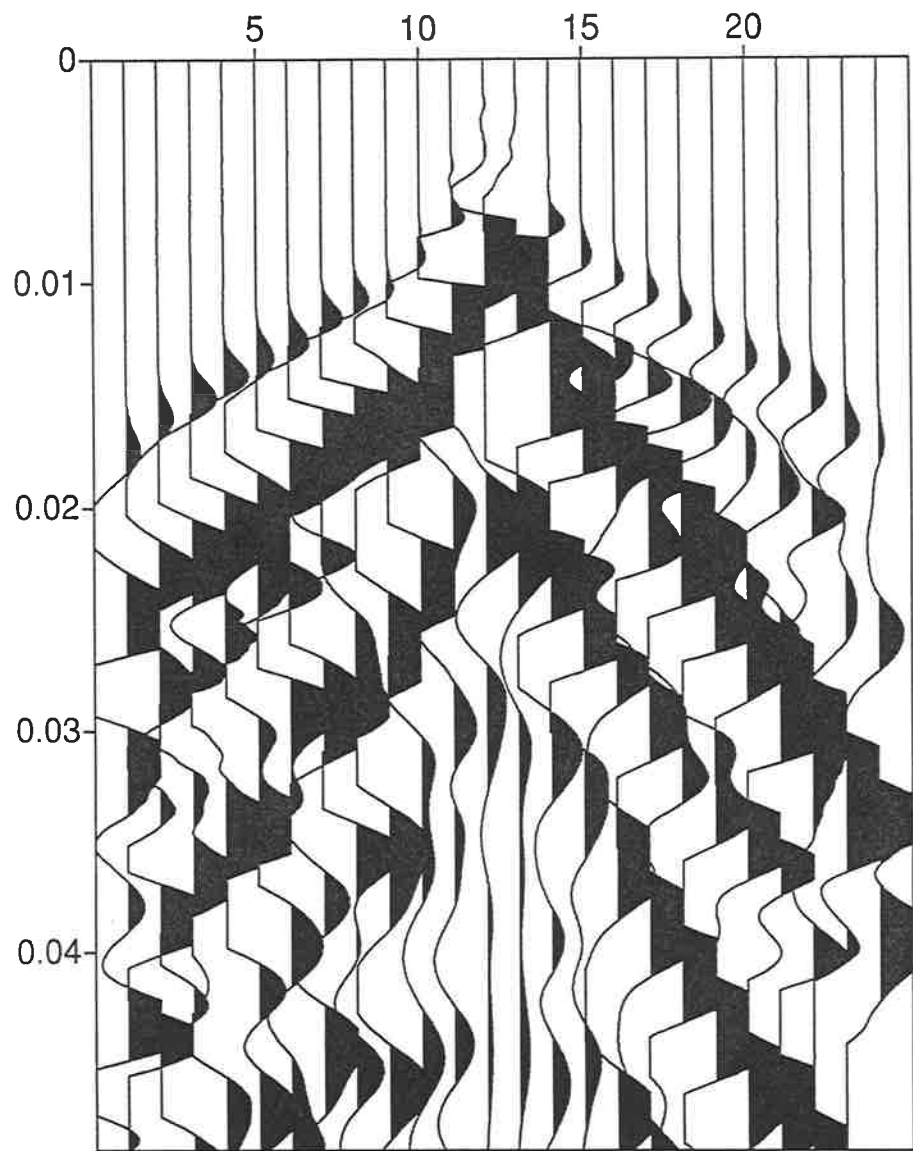
- (a) Pediment Run 2 (P2 *in* Figure 3.10a): south end test shot (500 samples), geophones spaced at one metre intervals.
- (b) Pediment Run 2 (P2 *in* Figure 3.10a): south end test shot (1000 samples), geophones spaced at one metre intervals.
- (c) Pediment Run 4 (P4 *in* Figure 3.10a): centre shot, geophones spaced at one metre intervals.
- (d) Pediment Run 5 (P5 *in* Figure 3.10a): east end shot, geophones spaced at three metre intervals.
- (e) First breaks from Pediment Run 1 (P1 *in* Figure 3.10a):  $V_1 - 590\text{ms}^{-1}$ ,  $V_2 - 1100\text{ms}^{-1}$ . Refractive layer at 1.8 metres interpreted as contact between alluvial pediment cover and (weathered) bedrock.



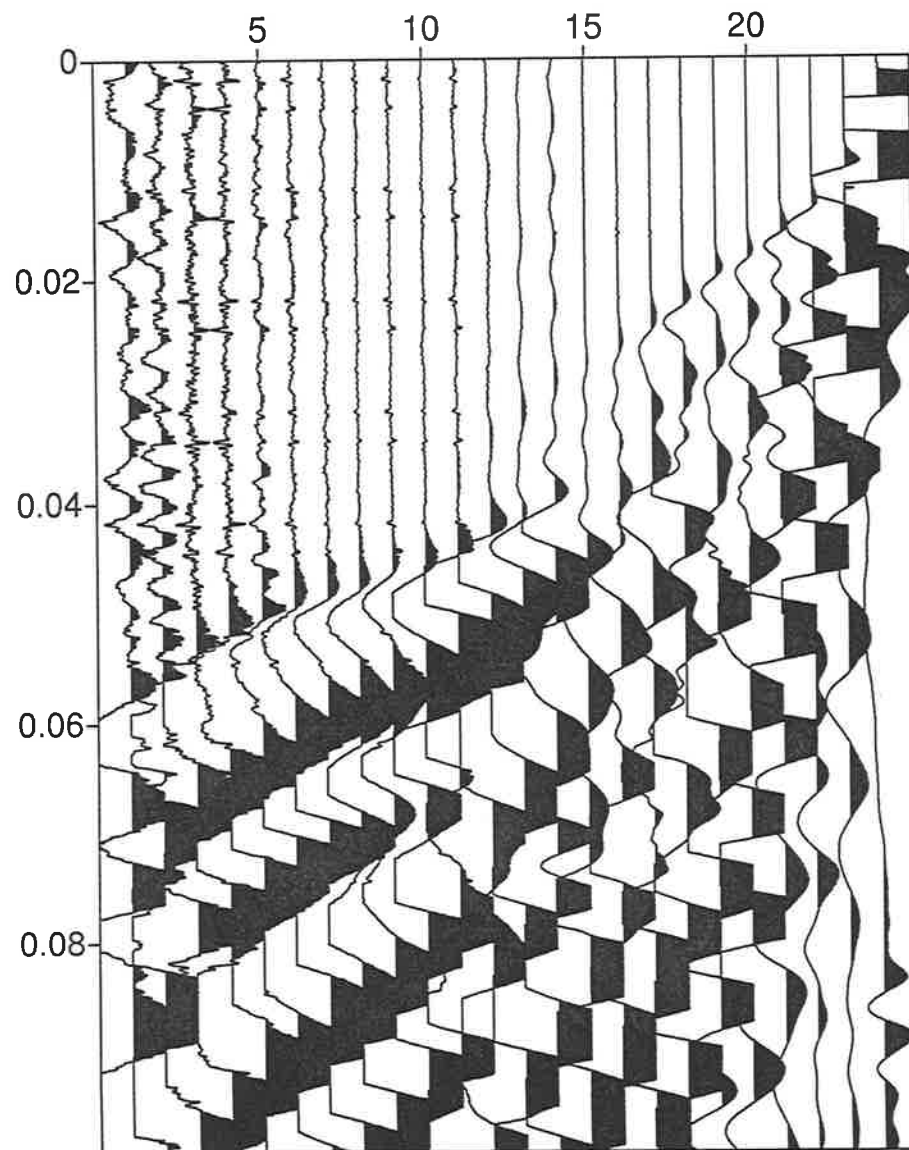
a



b



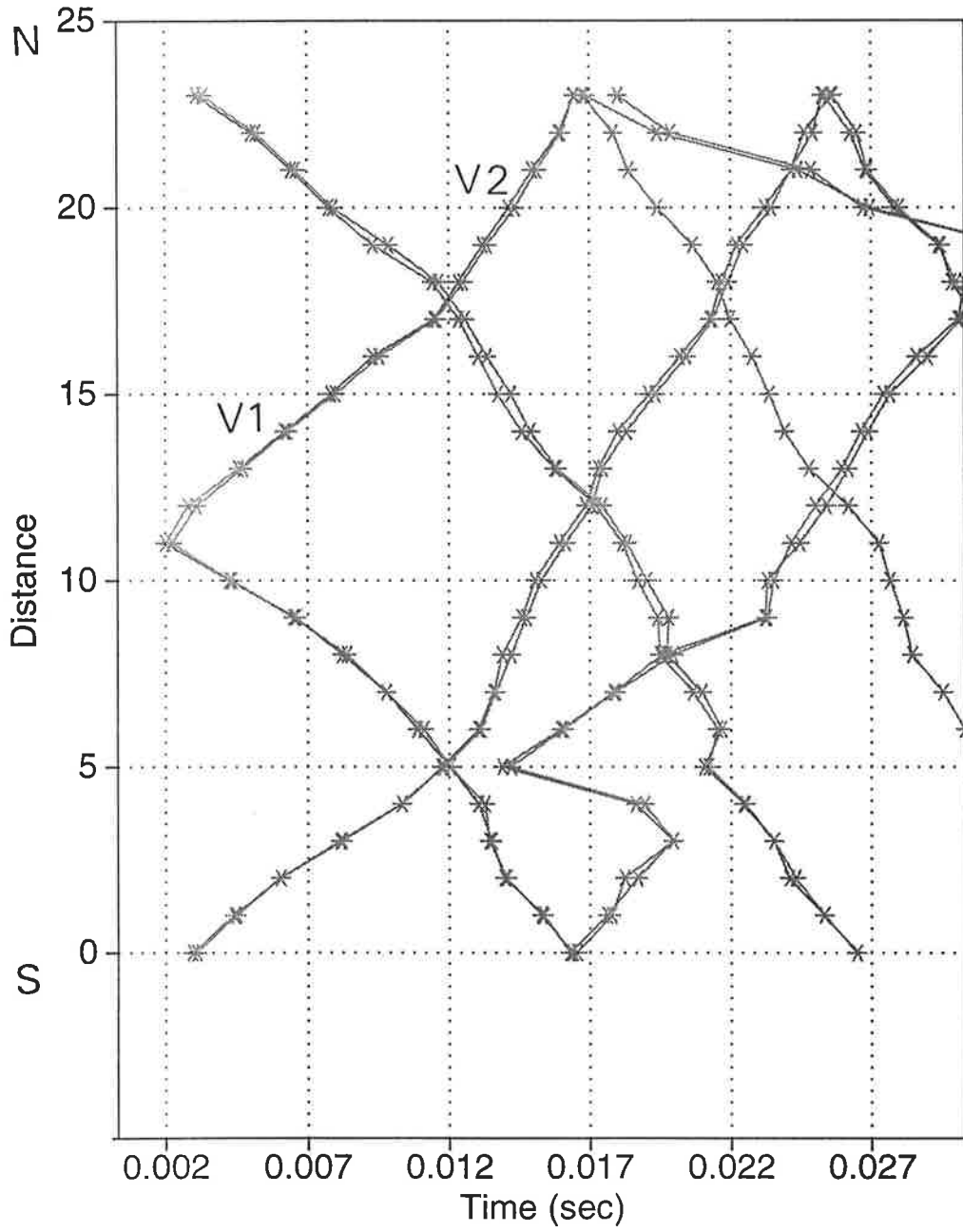
c



d



# First Breaks from Run 1

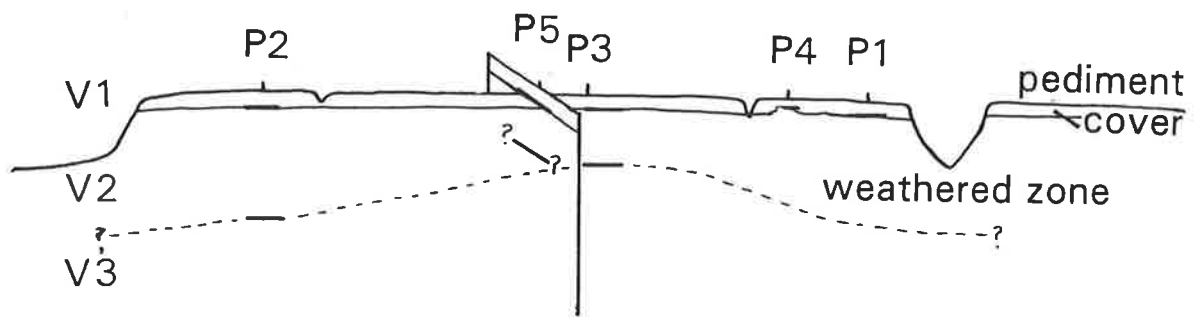


e

Figure 3.16

- (a) Section drawn from results of shallow seismic refraction survey (see Table 3.2)
  
- (b) Diagram of presumed behaviour of water table.

a. HAYWARD PEDIMENT



b.

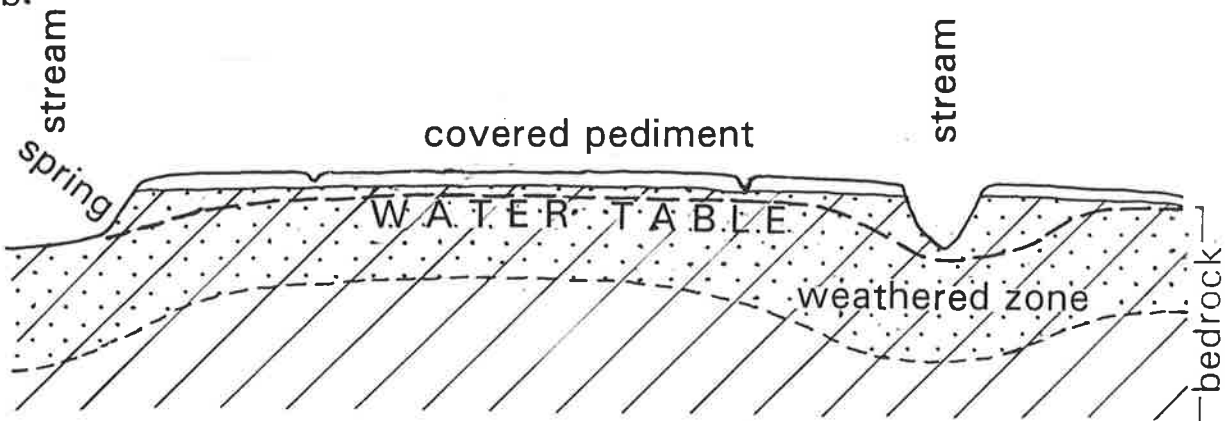


Figure 3.17 (MAP POCKET)

Bundulla-Walkandi high pediment remnants in the piedmont of the Heysen Range. Special Project Map, 2 metre form lines (vertical accuracy +/-2 to 3 metres), using data base for 1:50 000 Topographic Series, map sheet 6635-3 *Oraparinna* (Resource Information Group, Department of Environment and Natural Resources, South Australia).

Figure 3.18

Bundulla-Walkandi high pediment remnants stand up to 50 metres above the level of the main pediment. The higher, and therefore older, remnants are furthest from the scarp. The projected level of the high surface is marked on the escarpment by a break of slope. Streams are eroding a modern pediment (foreground) some 20 metres below the level of the main pediment.



### Figure 3.19

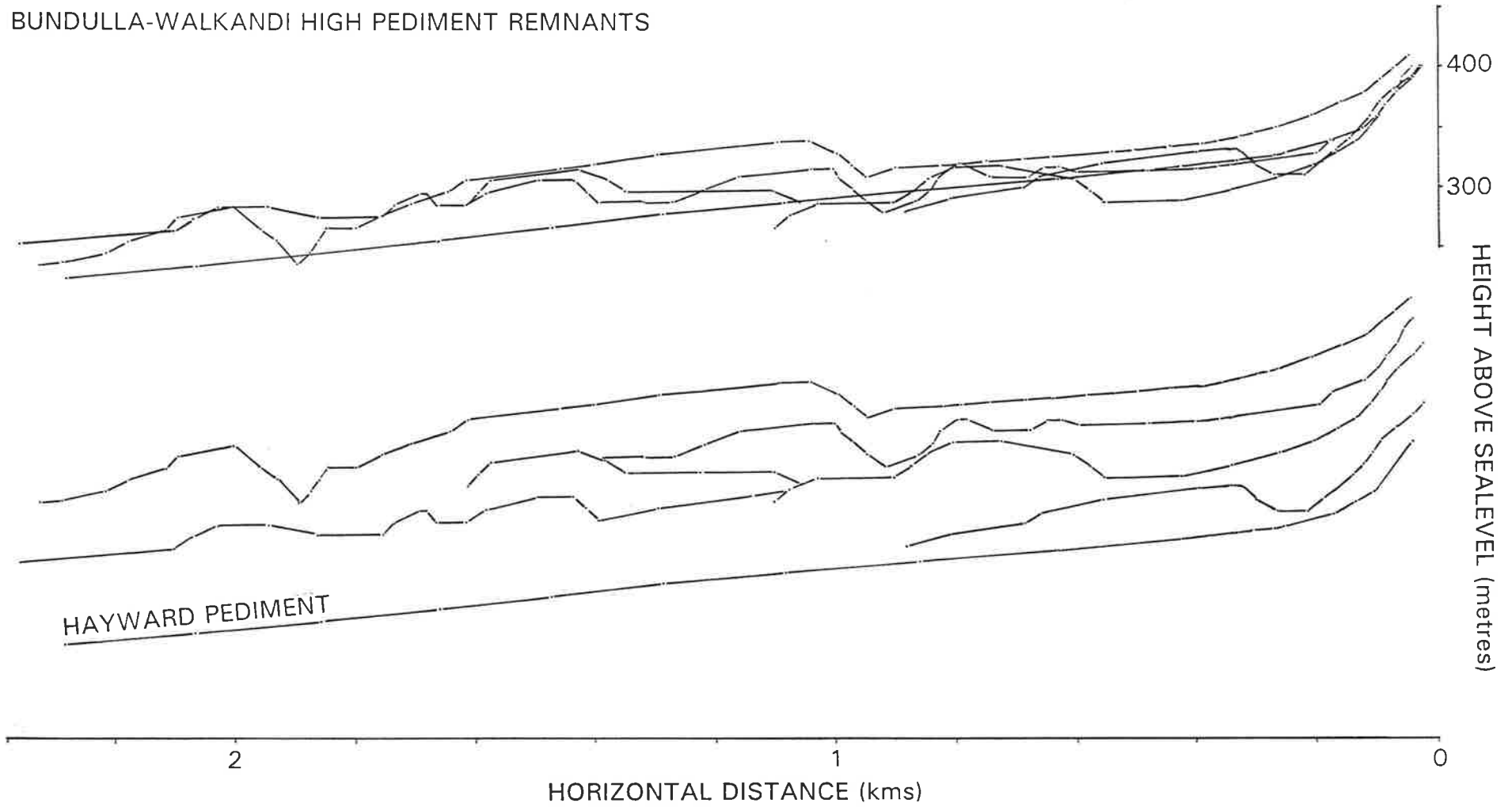
Profiles of Bundulla-Walkandi high pediment area are compared with that of Hayward Pediment, which is part of the main pediment

(a) profiles superimposed

(b) profiles separated

Source: Special Project Map, see Figure 3.17.

BUNDULLA-WALKANDI HIGH PEDIMENT REMNANTS



HAYWARD PEDIMENT

HORIZONTAL DISTANCE (kms)

HEIGHT ABOVE SEALEVEL (metres)



Figure 3.20

Map of drainage basins excluding those related to major alluvial fans: Parachilna-Edeowie region (see Table 3.1).

Source: 1:50 000 Topographic Series, map sheets 6534-1 *Moralana*, 6534-4 *Wilpena*, 6535-1 *Parachilna*, 6535-2 *Edeowie*, 6635-3 *Oraparinna*, 6635-4 *Blinman*, Department of Environment and Natural Resources, South Australia.

DRAINAGE BASINS: PARACHILNA-EDEOWIE REGION

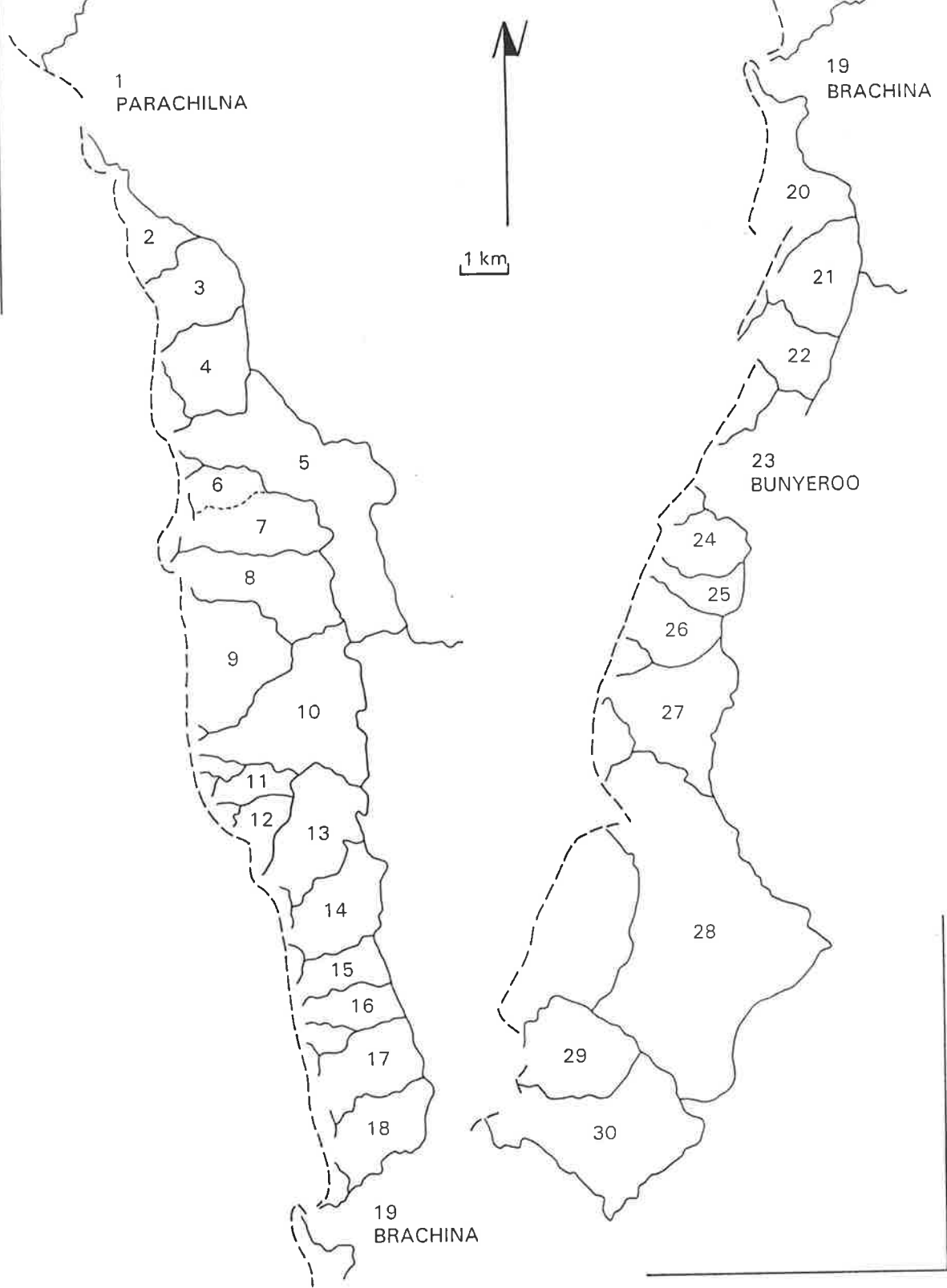


Figure 3.21

The alluvial cover, approximately one metre thick, protects remnants of the high pediment surfaces (left). Several peaks and rounded hills without an alluvial cover stand above the level of the main covered pediment, which slopes gently, left to right, down towards the Brachina Alluvial Fan.



Figure 3.22

(a) Oblique aerial view from the west of the Bunyeroo 'high' pediment (right foreground) and the Flinders Ranges upland. Note the influence of structure on the shape in plan of the pediment remnant and its proximity to Bunyeroo Creek, which provides the local baselevel for streams dissecting the pediment on either side.

(b) View along the northern margin of the Bunyeroo pediment of orthoquartzite outcrops which buttress the distal slopes of the remnant (see also Figure 3.23).

(c) Sedimentary structures in orthoquartzite. Hammer 30cm long.

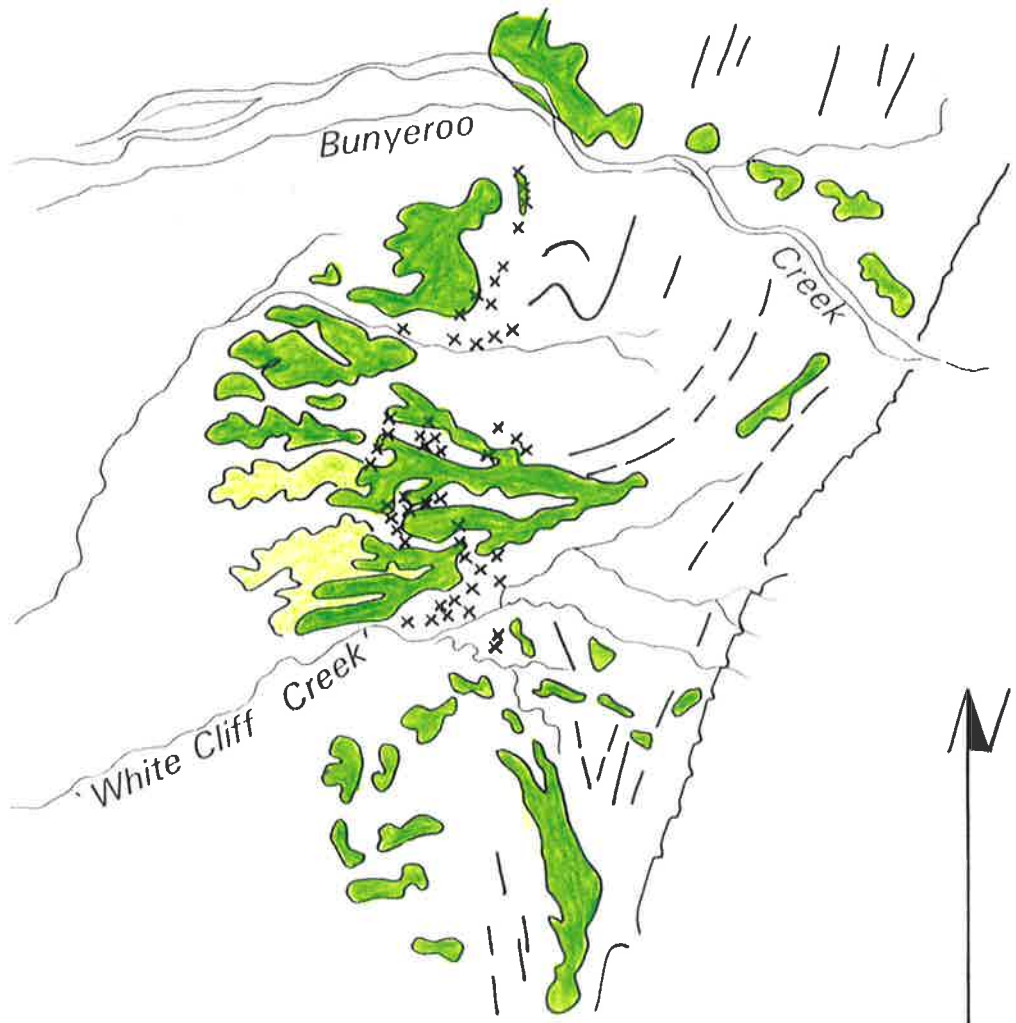


Figure 3.23





Map of orthoquartzite outcrops and the Bunyeroo 'high' pediment.

Source: Aerial Photography, Survey 2501/002, 1979, Department of Environment and Natural Resources, South Australia.

# BUNYEROO "HIGH" PEDIMENT



## LEGEND

-  Pediment remnants
-  Orthoquartzite
-  Upland margin
-  Strike ridge

## SCALE





Figure 3.24

Modern pediment eroded at the expense of the main pediment by a tributary of Brachina Creek (see also Figure 3.18). Note the structural ridge to the east (right of view) which carries no alluvial detritus and probably represents a dissected remnant of the former pediment level which included the Lookout hill/mesa, from which the photograph was taken.

Figure 3.25

The dissection of the main pediment surface results in mesas and low, rounded hills, which stand above the level of the modern pediment eroded by tributaries of Bunyeroo Creek.

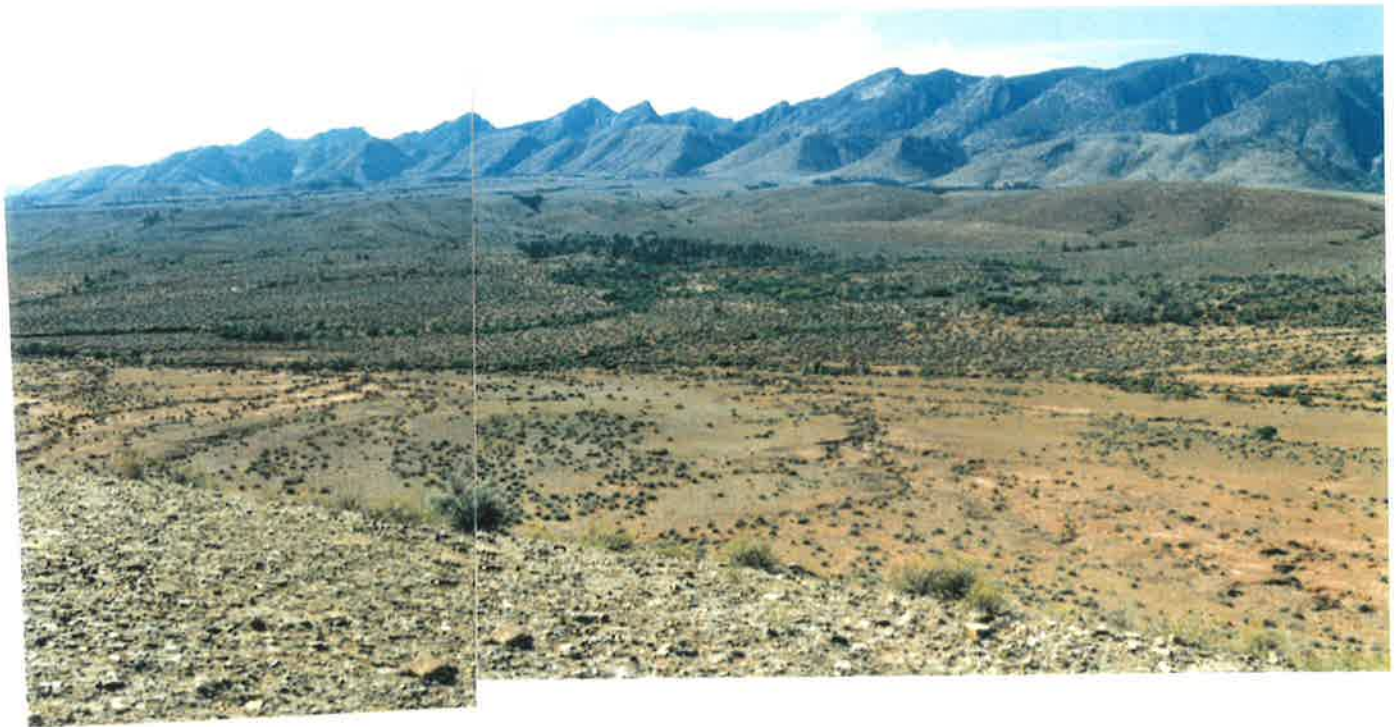


Figure 3.26

- (a) Low structural ridges (foreground) stand above the modern pediment associated with 'White Cliff Creek'. The Creek is named for the weathered Cambrian bedrock exposed where the stream has undercut the margin of the Bunyeroo 'high' pediment (see white patch left background).
- (b) Pediment cover of alluvial detritus over weathered Cambrian bedrock in White Cliff section. Height of figure 1.5 metres.
- (c) Surface of the modern pediment associated with 'White Cliff Creek' scored by a pattern of rills marked by small calibre bedload deposits. Eventually such deposits will cover, and protect from further erosion, the pediment surface cut in bedrock.
- (d) Surface of the modern pediment being eroded at the foot of Rawnsley Bluff, the southeastern extremity of Wilpena Pound. A surface pattern of old channel deposits, similar to that noted in (c) but of coarse detritus, is left behind to protect the surface as the stream channel migrates.

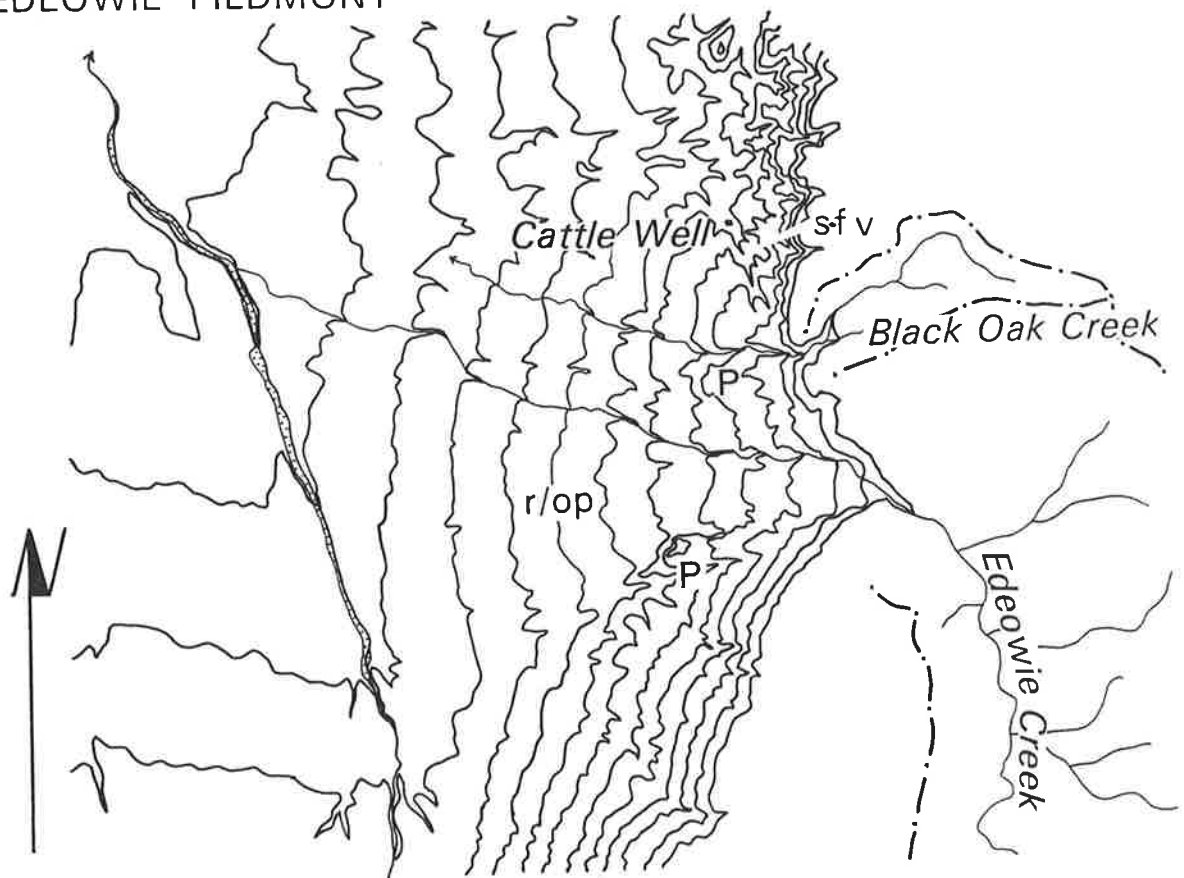


Figure 3.27

Map of the Edeowie riverine outwash plain (r/op), which is virtually a flat flood plain, compared to the slightly convex-upward transverse profile of the Edeowie pediment surface (P) to the north. The pediment is separated from the upland by a scarp foot valley (s-f v) eroded by tributaries of Cattle Well Creek (see also Figure 3.28).

Source: 1:50 000 Topographic Series, map sheets 6535-2 *Edeowie*, 6535-3 *Oraparinna*, Department of Environment and Natural Resources, South Australia.

EDEOWIE PIEDMONT



SCALE

0 1 2 3 kms

CONTOUR INTERVAL: 10 metres

### Figure 3.28

Oblique air photograph of the Edeowie riverine outwash plain looking southeast into Wilpena Pound, which encompasses the Edeowie Creek catchment. The riverine outwash plain has developed at the expense of the southern half of the Edeowie Pediment. Note white of weathered bedrock eroded at the margin of the pediment remnant, marked P *in* Figure 3.27, in the scarp foot zone.

(Aerial Photography, Survey 4373/027, 1991, Department of Environment and Natural Resources, South Australia)

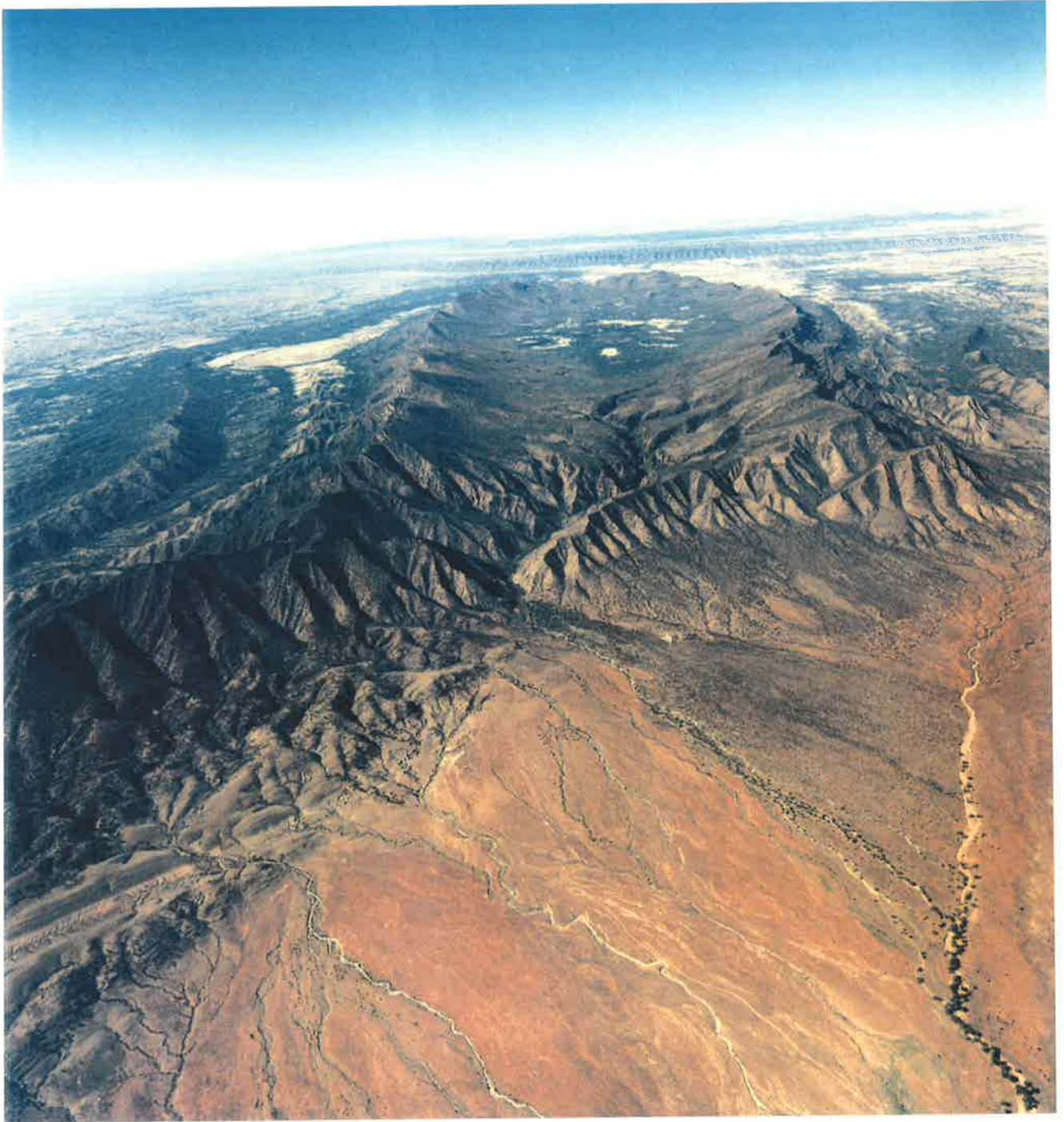




Figure 3.29

Topographical cross sections of the bars and channels of Brachina Creek (after Doeglas, 1962), at the point where the stream leaves the channel incised in the pediment apron and deposits an alluvial fan. Measurements taken 7 November 1991 and 23 November 1993. Very little change is apparent, although the river flooded in response to summer rainstorms in January 1992.

BRACHINA CREEK

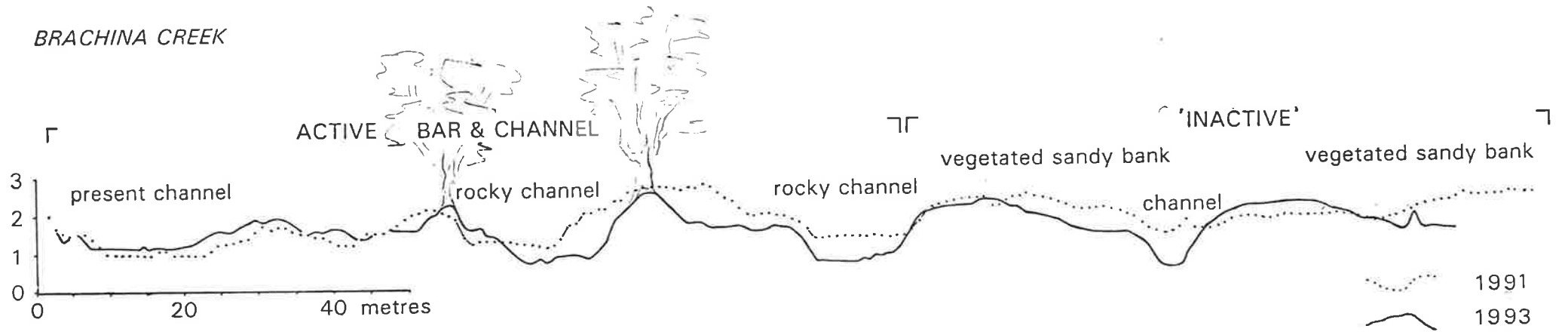


Figure 3.30

Alluvial fan and catchment area of Deep Creek, Wyacca-Emeroo region

(a) Computer generated block diagram of Deep Creek Alluvial Fan and its catchment in Emeroo Range. Note the truncated bevelled spurs in the scarp foot south of Deep Creek (right of diagram), which may be remnants of the upper slopes of a covered pediment, most of which surface has been downfaulted and lies beneath the alluvial fan deposits. Remnants of the pediment surface occur behind protective structural ridges in the scarp foot zone to the north of the Creek. (Research Information Group, Department of Environment and Natural Resources, South Australia)

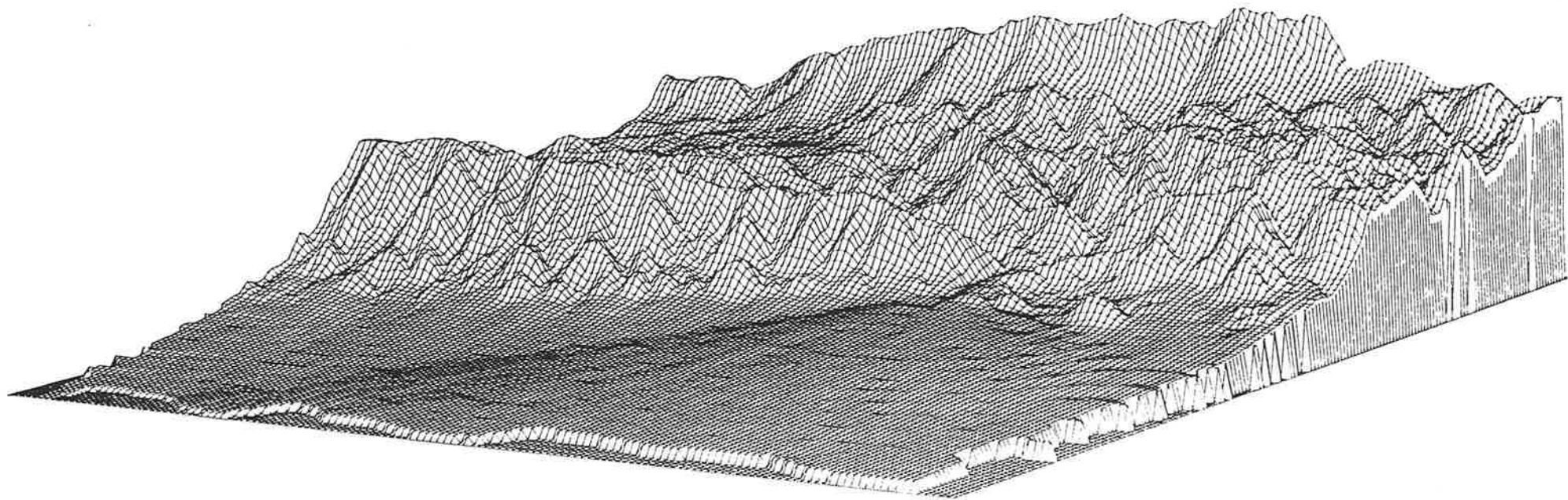


Figure 3.30

Alluvial fan and catchment area of Deep Creek, Wyacca-Emeroo region

(b) View of (a) at ground level

(c) Field sketch of the bevelled spurs south of Deep Creek gorge.

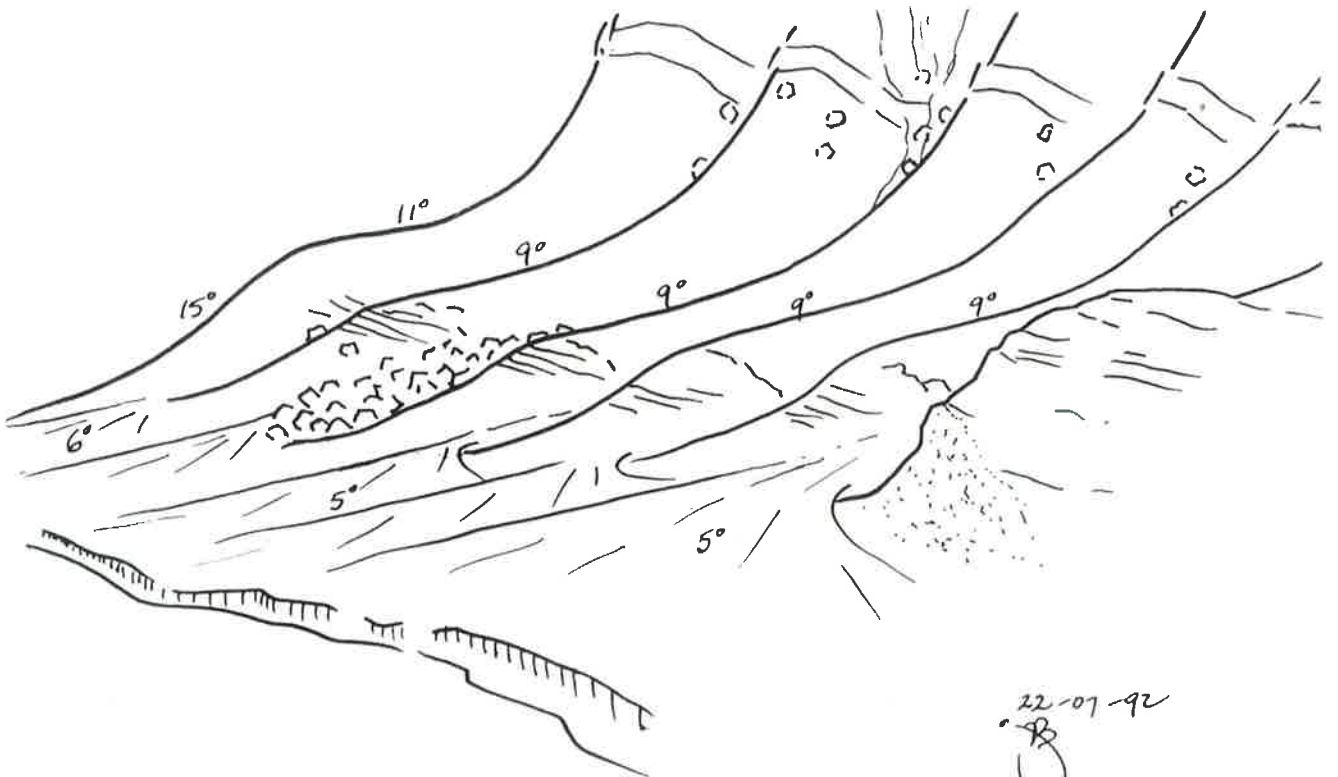
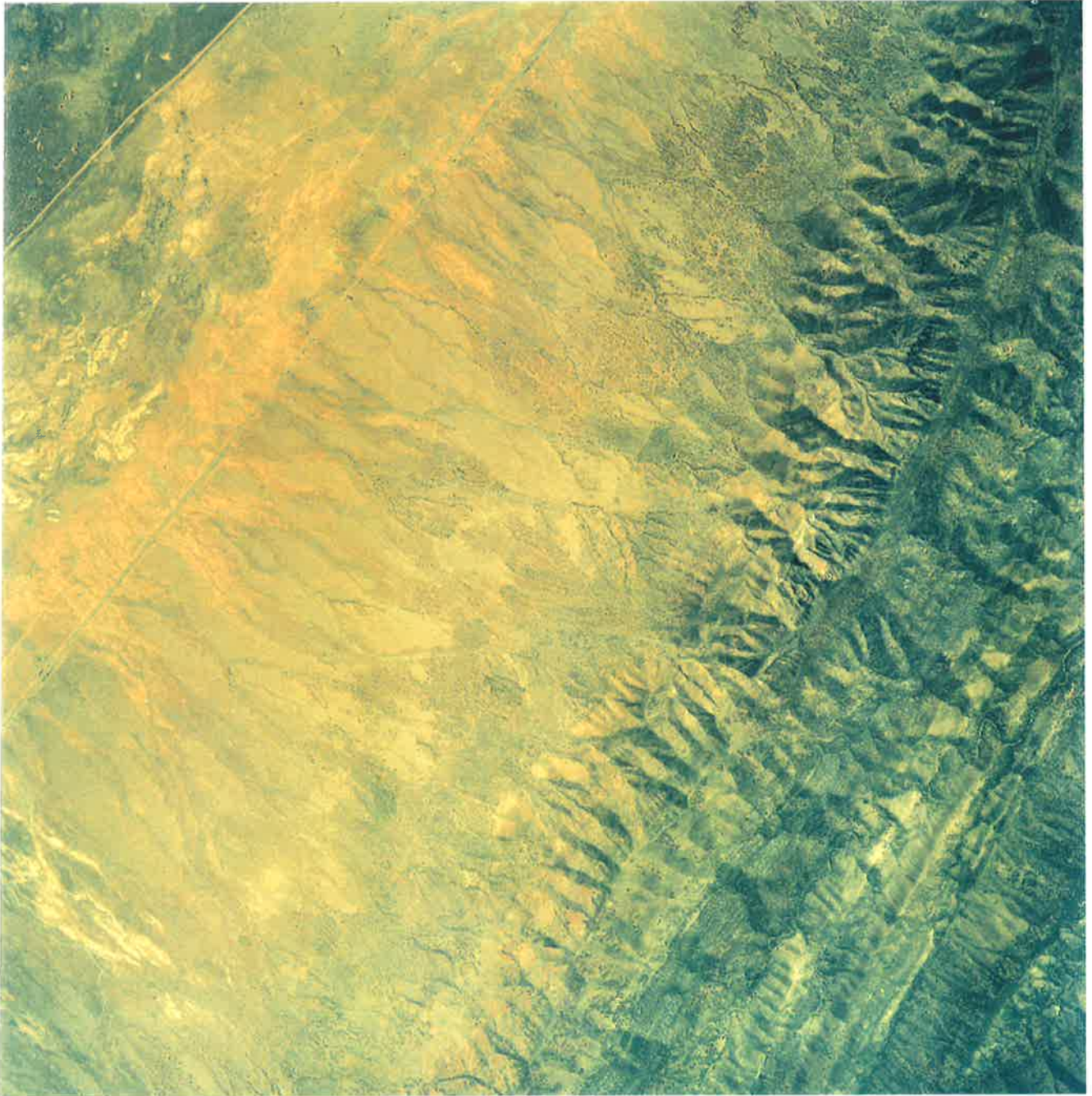


Figure 3.31

The alluvial cover of pediments at the foot of Wyacca Range thickens downslope as it merges with the alluvial basin deposits shown in:

(a) vertical air photograph of part of the Wyacca Range piedmont

(Aerial Photography, Survey 4304/163, 1991, Department of Environment and Natural Resources, South Australia).





### Figure 3.31

The alluvial cover of pediments at the foot of Wyacca Range thickens downslope as it merges with the alluvial basin deposits shown in:

(b) ground level view looking southeast across the piedmont

### Figure 3.32

Several narrow, bevelled spurs are regarded as remnants of a covered pediment surface immediately north of Depot Creek. The pediment stands some 50 metres above the level of the alluvial fan surface (foreground).



Figure 3.33

(a) Remnants of the pediment surface north of Thompson Creek are protected by a discontinuous ridge of resistant rock, parts of which appear bare of vegetation (middle ground).

(b) Field sketch emphasises the protection afforded the pediment surface by the disposition of strata.

Figure 3.34

Pediment surface north of Deep Creek protected by a rampart of resistant strata (right). Note the break of slope related to the pediment surface marked by weathered bedrock exposed in the scarp foot.

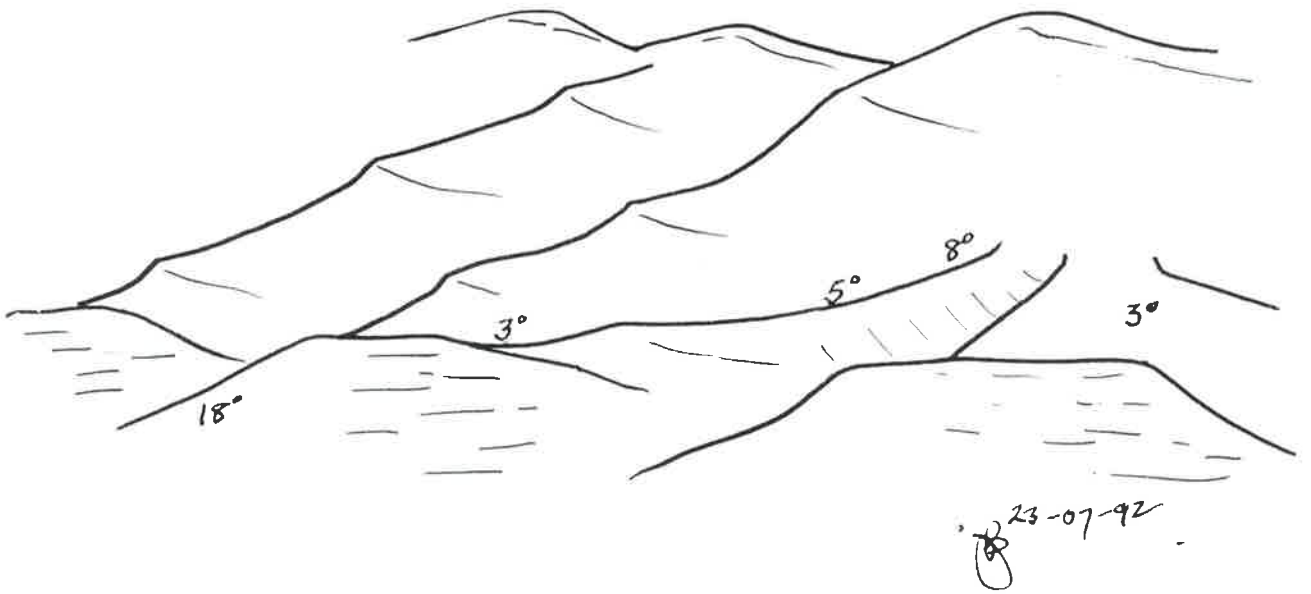


Figure 3.35

- (a) Field sketch of the pediment embayment eroded by South Creek.
  
- (b) View looking into the embayment and, in the foreground, across a broad river terrace some 15 metres below the level of the pediment surface.

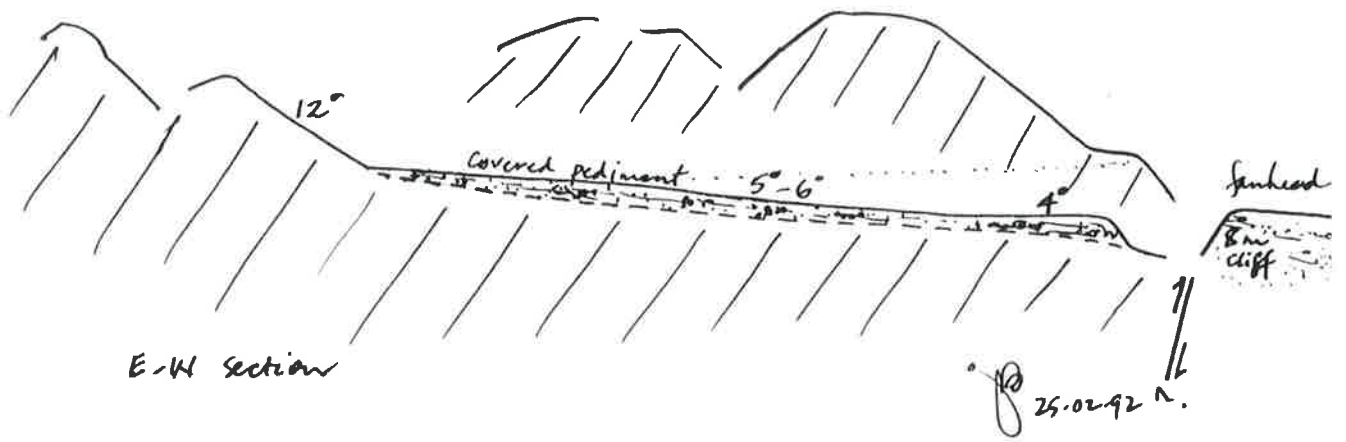
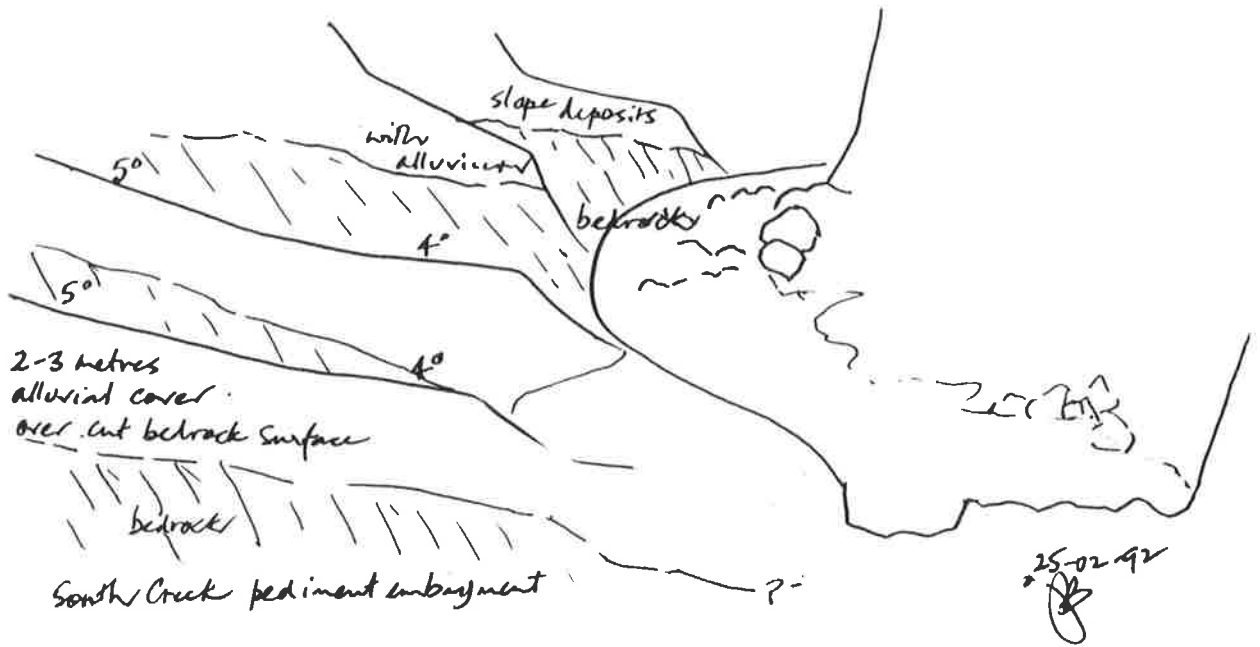


Figure 3.36 Relationship of pediment and alluvial fan surfaces.

(a) The covered pediment remnant, distinguished by blue-grey vegetation, at the mouth of the Deep Creek pediment embayment stands some 20 metres above the surface level of Deep Creek Alluvial Fan.

(b) The covered pediment surface fringing the upland stands 50-60 metres higher than the alluvial fan deposits of South Creek (foreground).





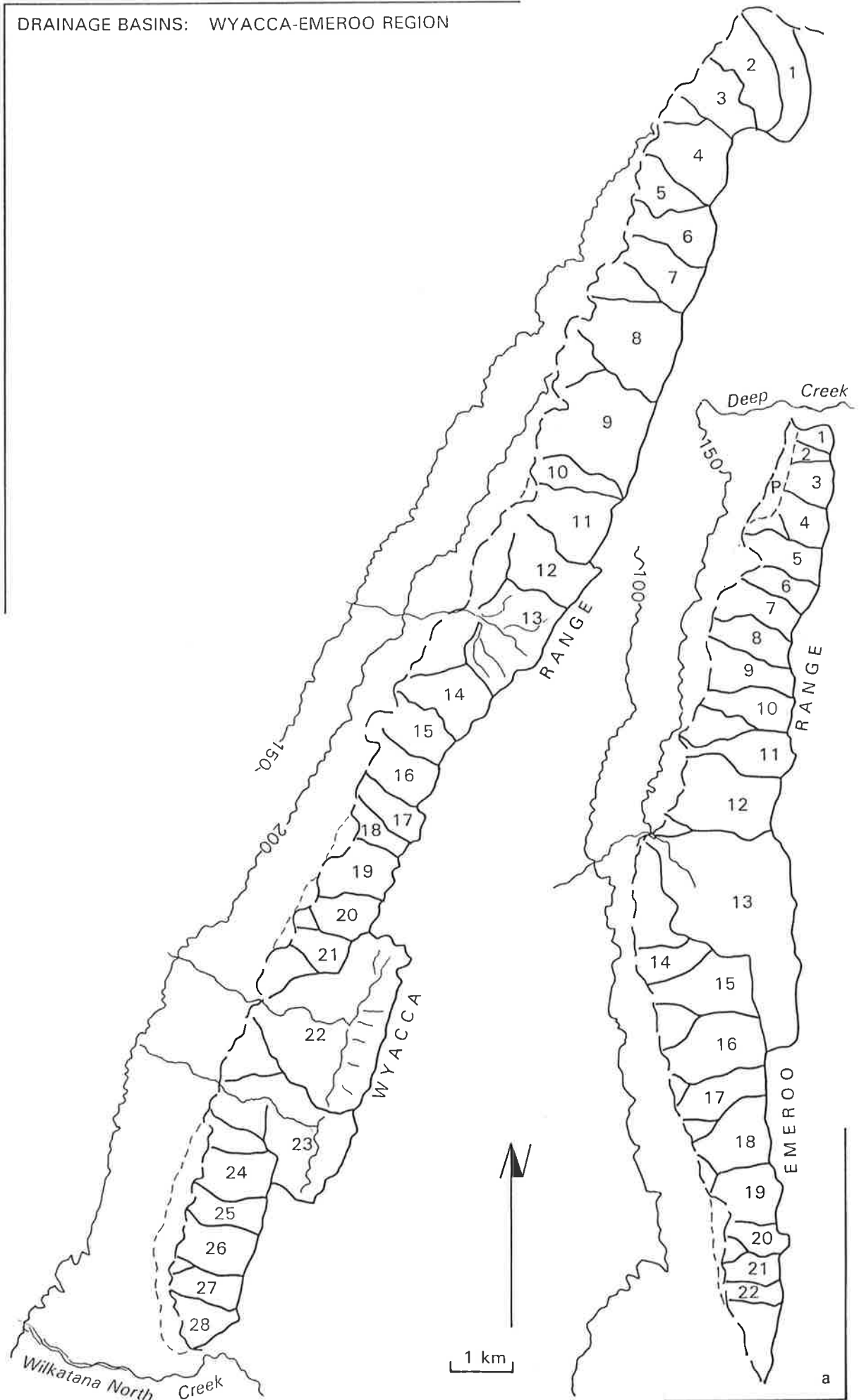
Figure 3.37

Drainage basins other than those associated with major alluvial fans of the Wyacca-Emeroo region. The inner piedmont zone, including covered pediments (P) and the apices of alluvial fans, is defined by major streams, upland margin (dashed line) and selected contours. (See Tables 3.3 & 3.4 for the catchment area and the average size of catchment for each section of the upland.)

(a) Wyacca and Emeroo ranges. In the Wyacca Range only catchments 22 & 23 have eroded beyond the Emeroo Quartzite into Skillogalee Dolomite. In the Emeroo Range catchments 1-12 are also eroded in Emeroo Quartzite, and although catchments 14-22 occur in older strata, there is no marked contrast in size. Catchment 13, however, is larger because Ukat Creek has eroded weaker rock in the older sequence at the lithological boundary with Emeroo Quartzite. Note the location of catchments mentioned in Table 4.1, viz. 22-Wilk N and 23-Wilk S in the Wyacca Range, 13-Ukat, 15-Emeroo N, 16-Emeroo S in the Emeroo Range.

(b) Central Section between Wyacca and Emeroo ranges. Catchments are eroded in Emeroo Quartzite except for the sector between Thompson and South creeks where the pediments are eroded across the Quartzite and the escarpment is Skillogalee Dolomite.

DRAINAGE BASINS: WYACCA-EMEROO REGION



DRAINAGE BASINS: WYACCA-EMEROO REGION

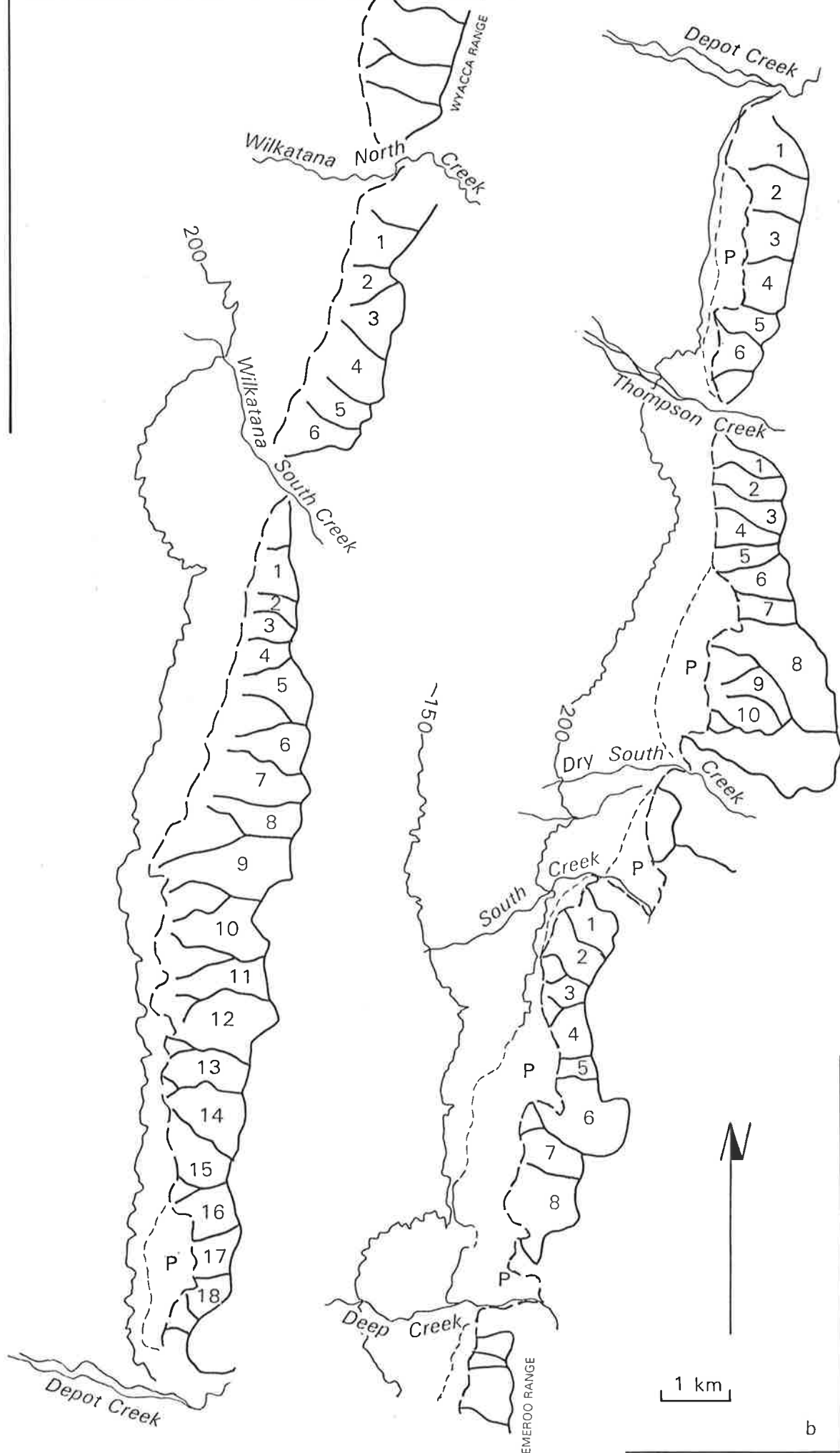
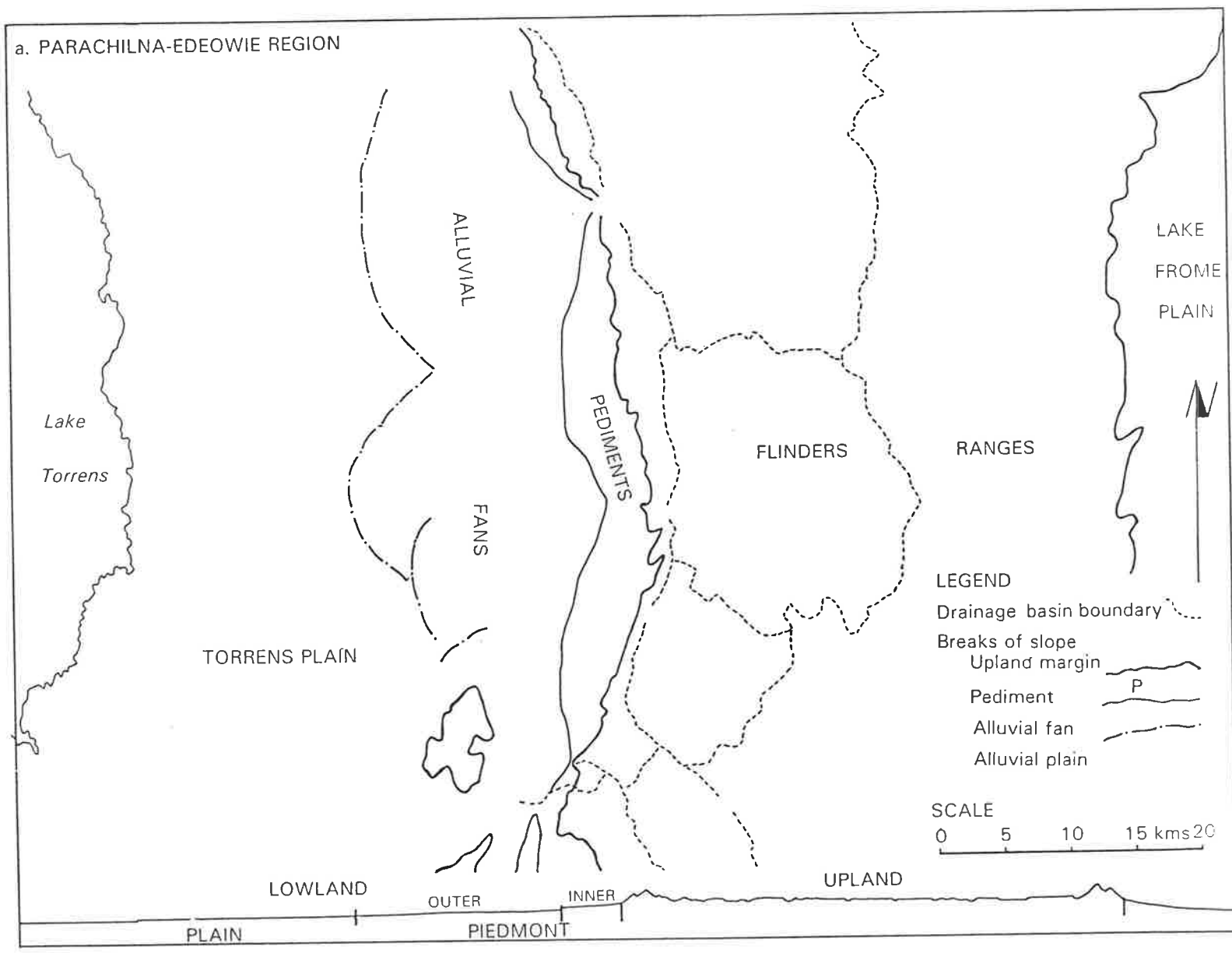


Figure 4.1

Alluvial fans dominate the study area.

- (a) Parachilna-Edeowie region
- (b) Wyacca-Emeroo region



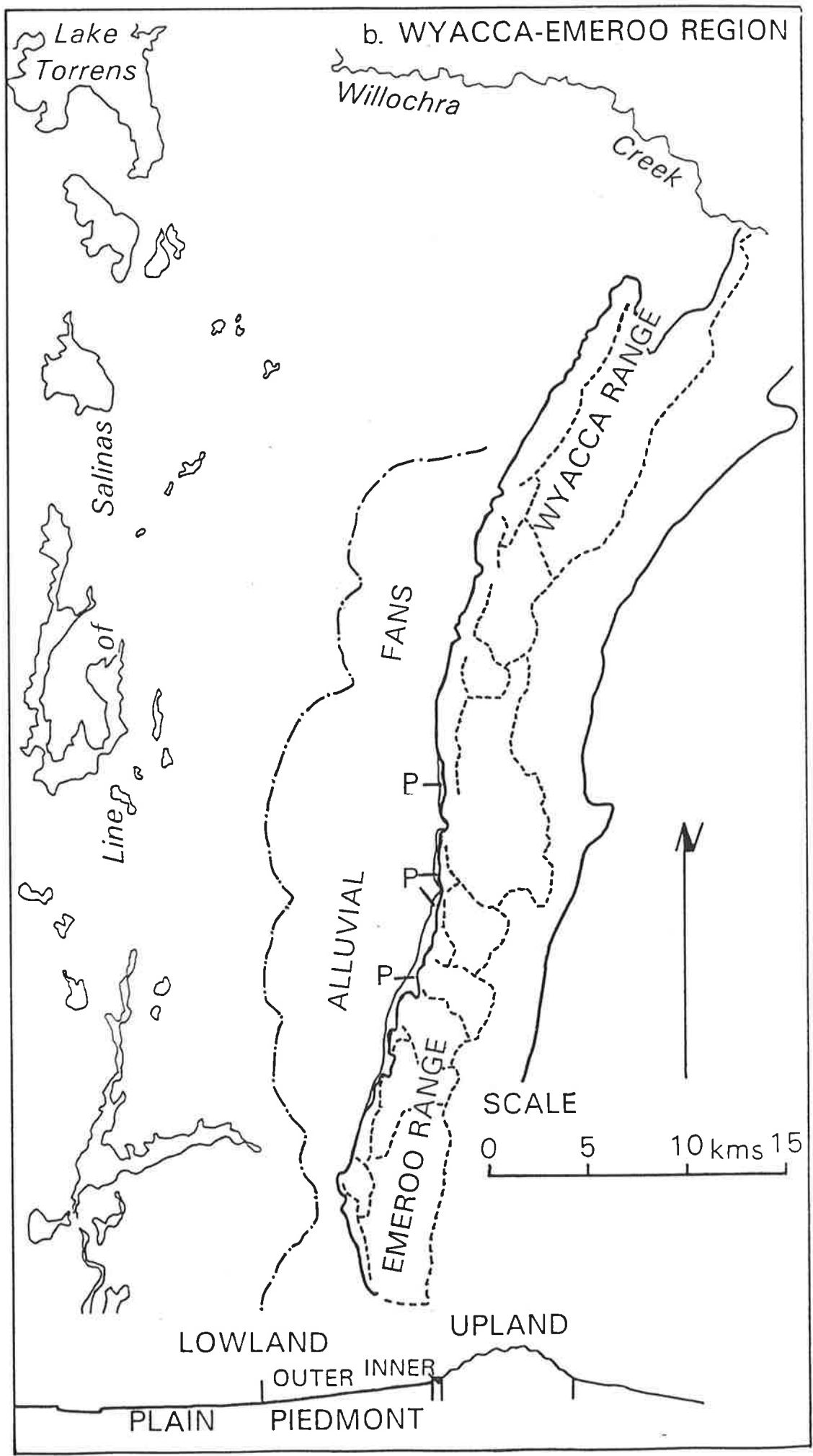


Figure 4.2

Diagrammatic profiles of (a) Parachilna-Edeowie region and (b) Wyacca-Emeroo region show that major alluvial fans in the study area are backed by uplands, which stand high above the piedmont. Those upland sectors backing the pediments are lower.

Source: 1:50 000 Topographic Series, map sheets 6433-1 *Wilkatana*, 6433-2 *Port Augusta*, 6533-4 *Willochra*, 6534-3 *Neuroodla*, 6535-1 *Parachilna*, 6535-2 *Edeowie*, 6635-3 *Oraparinna*, 6635-4 *Blinman*, Department of Environment and Natural Resources, South Australia.

#### LEGEND

- a Line joining high points (H/P in Table 4.4) in catchments related to major alluvial fans
- b Line joining high points (H/P in Tables 3.1 & 3.3) in catchments related to pediments (and riverine outwash plains and minor alluvial fans)
- c Hill-plain junction (piedmont angle where pediments occur)
- d Line joining apices of major alluvial fans
- e Line joining lowest points of major alluvial fans
- P Pediment
- F Alluvial fan

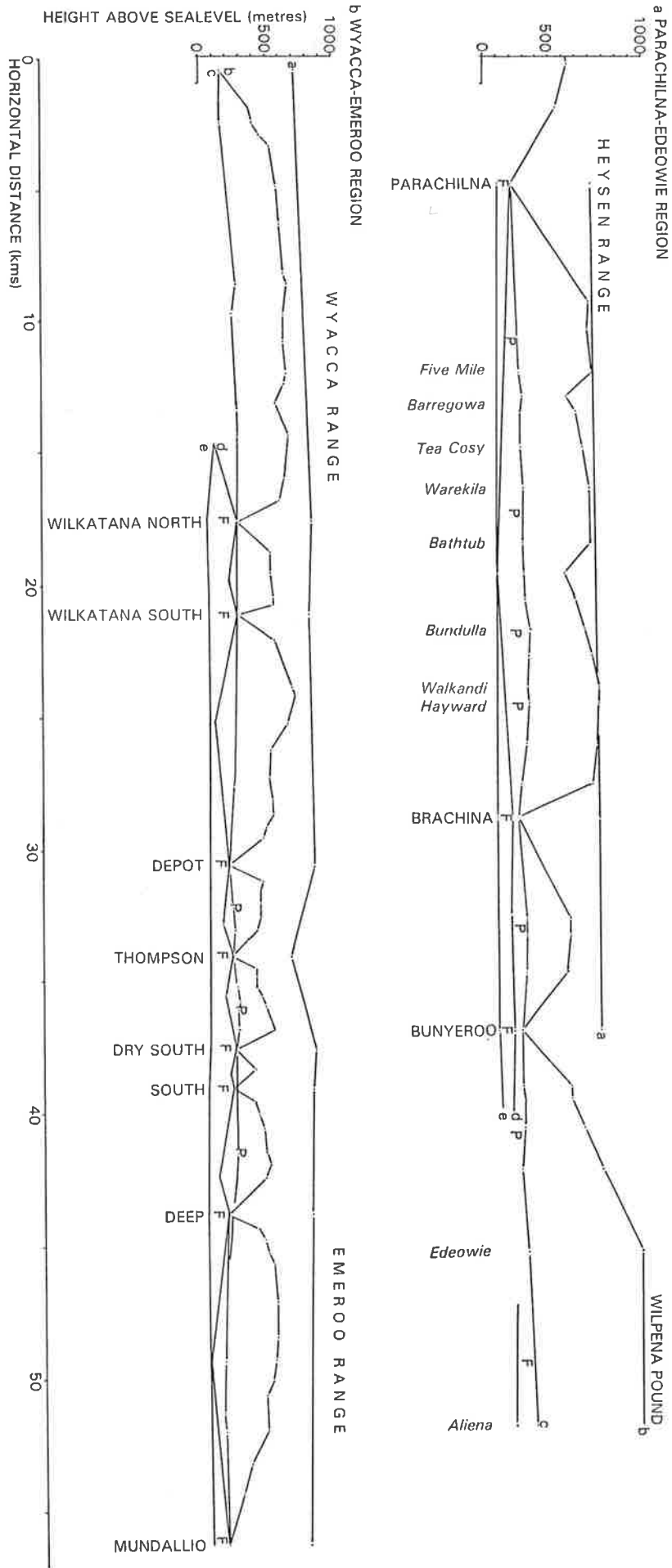




Figure 4.3

Drainage to Lake Torrens, Flinders Ranges, South Australia.

Source: 1:250 000 National Topographic Map Series, map sheets SH 53-16 TORRENS, SH 54-13 PARACHILNA, SI 54-1 ORROROO, SI 53-4 PORT AUGUSTA, South Australia, Edition I, Division of National Mapping.

# DRAINAGE TO LAKE TORRENS, FLINDERS RANGES, SOUTH AUSTRALIA

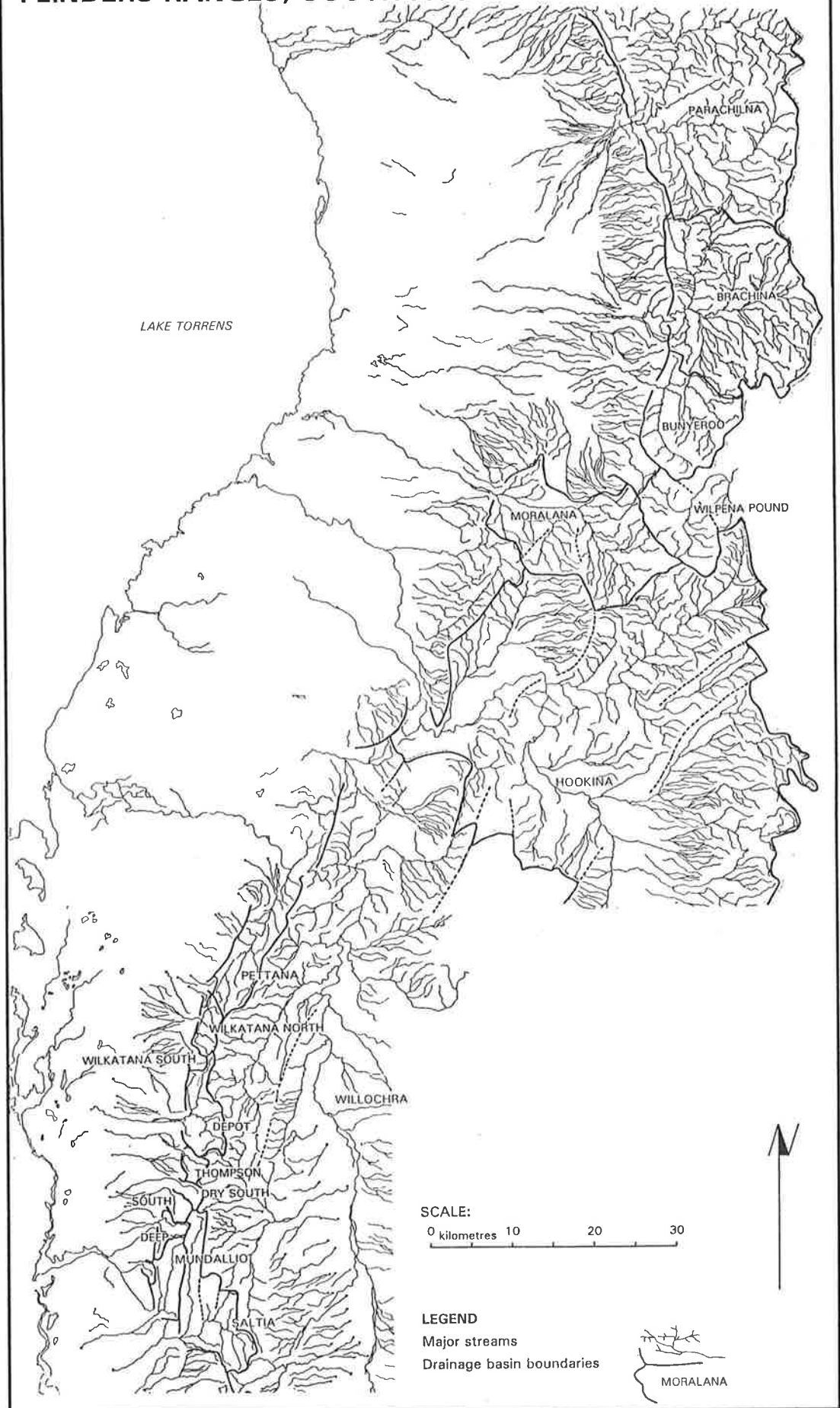
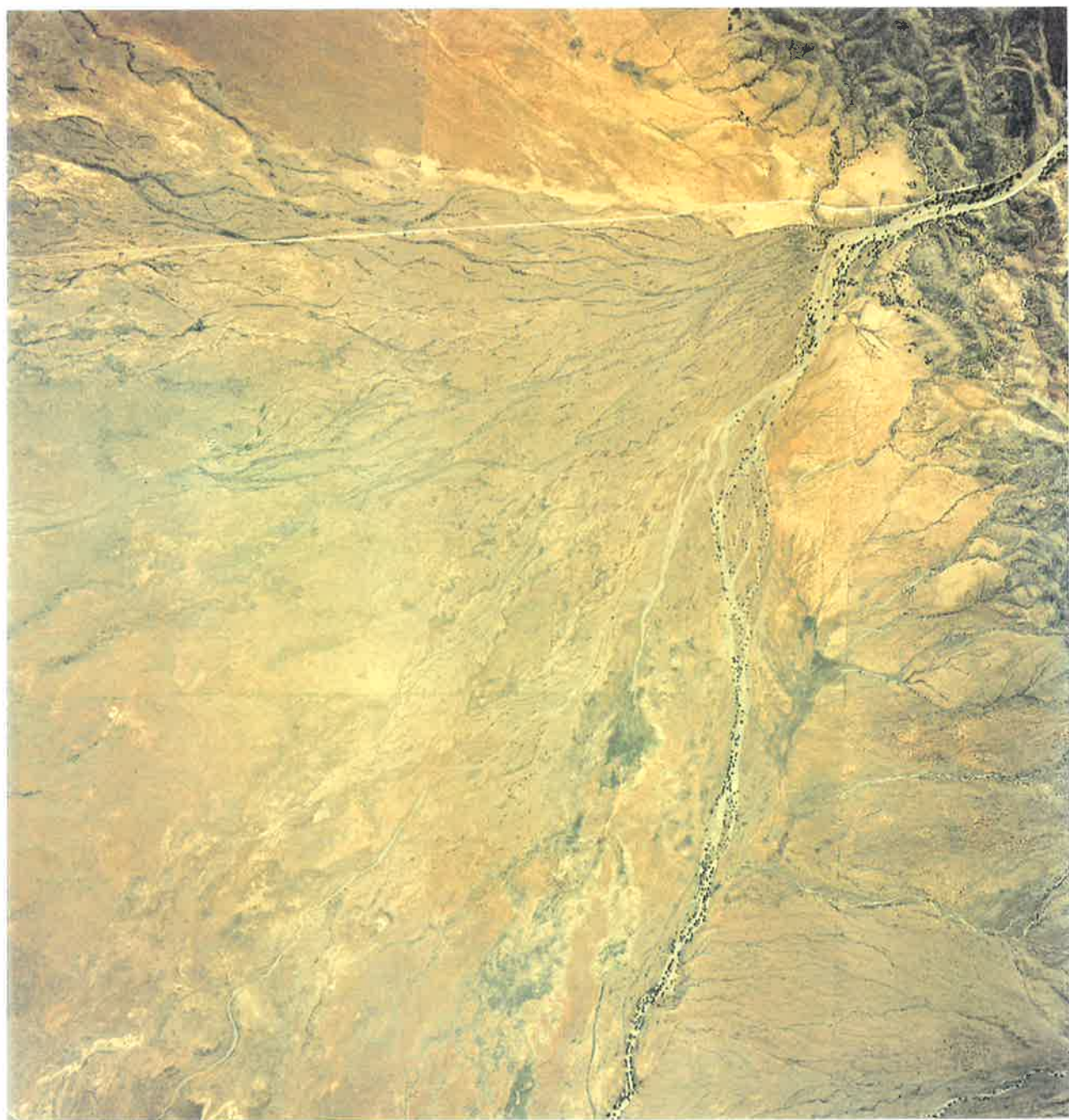


Figure 4.4

Vertical air photograph of Parachilna Alluvial Fan.

(Aerial Photography, Survey 2502/005, 1979, Department of Environment and Natural Resources, South Australia).



## Figure 4.5

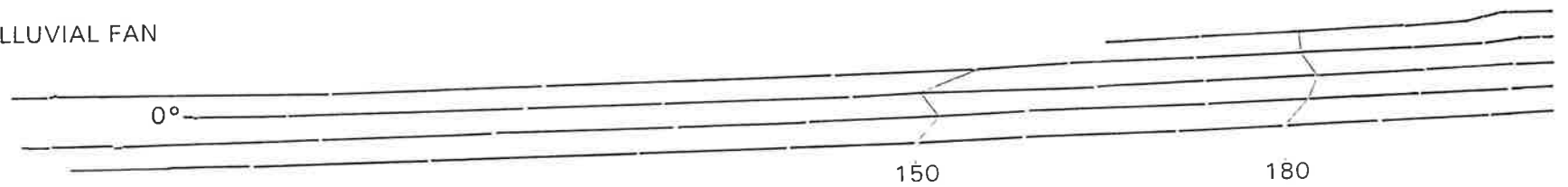
(a) Axis and azimuth profiles: Parachilna-Edeowie region. Upper parts of an alluvial fan tend to slope more steeply than distal parts and flanking slopes more than the axis, or longitudinal, slope.

The line of axis determined by the orientation of the last one hundred metres of the main channel within the upland. The azimuth of any other radius chosen (e.g.  $22.5^\circ$  &  $45^\circ$ ) is measured as an angular distance from the axis (after Hooke & Rohrer, 1979)

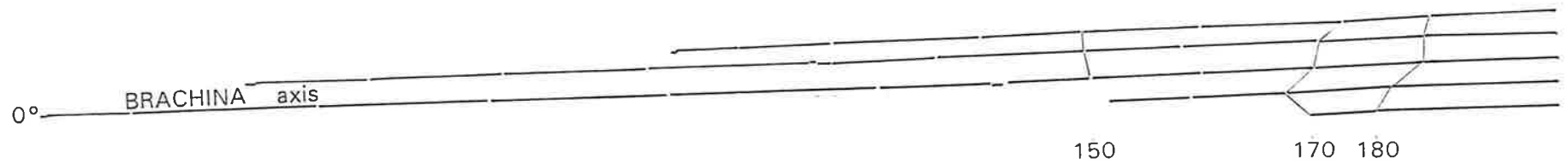
(b) Location of profiles indicated on accompanying map.

Source: 1:50 000 Topographic Series, map sheets 6535-1 *Parachilna*, 6535-2 *Edeowie*, 6635-3 *Oraparinna*, 6635-4 *Blinman*, Department of Environment and Natural Resources, South Australia.

PARACHILNA ALLUVIAL FAN

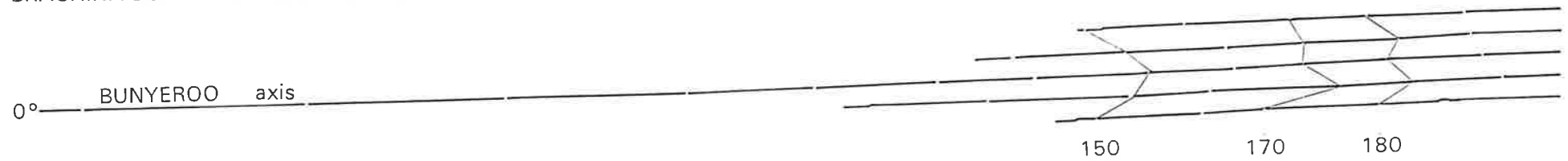


BRACHINA axis

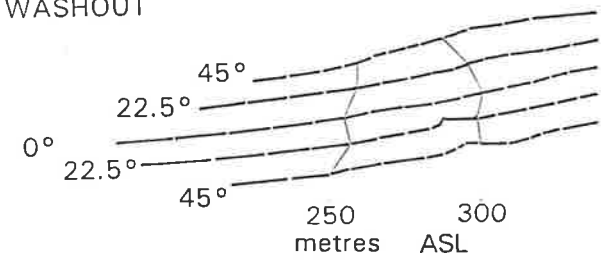


BRACHINA-BUNYEROO ALLUVIAL FAN

BUNYEROO axis



ALIENA WASHOUT



AXIS & AZIMUTH PROFILES: PARACHILNA-EDEOWIE REGION

AXIS & AZIMUTH: PARACHILNA-EDEOWIE REGION

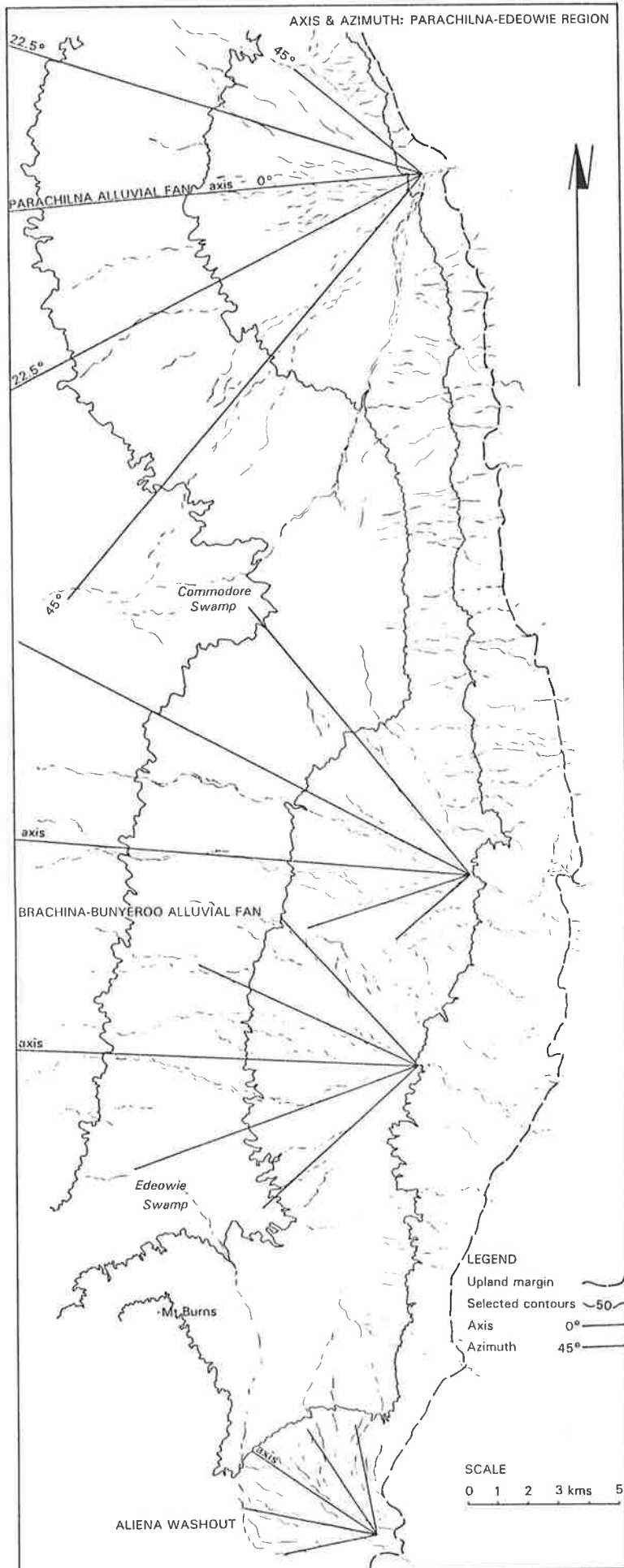


Figure 4.6

Oblique view of the upper slopes and catchment of Parachilna Alluvial Fan. Vegetation associations highlight different drainage texture domains on the alluvial fan surface. South (right) of the mouth of Parachilna Gorge, pediments fringe the upland. The level of the erosional surface is some 50 metres higher than that of the depositional feature.

Figure 4.7

Satellite imagery of Parachilna Alluvial Fan makes clear the variations in soil and vegetation, which indicate fan segments and secondary fan deposits. Note also the minor alluvial fan associated with Five Mile Creek, which emerges from the upland some 7 kilometres south of the mouth of Parachilna Gorge.

BAND	COLOUR GUN	DATA LIMITS	STRETCH
		WITHIN HISTOGRAM	
1 Visible Blue	Blue	40-126	Gaussian Equalise
3 Visible Red	Green	10- 90	Gaussian Equalise
7 mid I/Red	Red	2-105	Gaussian Equalise

Source: Landsat 5, Thematic Mapper data for December 1987.





Figure 4.8

Braided channels of Brachina Creek migrate laterally and erode their own earlier deposits. Lenses of coarse alluvial material are exposed in such profiles, but the bulk of the material consists of clay and sand.

(a) Brachina Creek Alluvial Fan is entrenched throughout its length. The stream is incised some 4 metres at this location in the midfan area. Lens of cobbles, at least one metre thick, in the alluvial fan deposits protects the northern bank of the Creek from undercutting. base of the cliff. Height of figure 1.5 metres.

(b) Upward-fining sequence exposed in 1.5 metre section cut in mid-channel bar of Brachina Creek. Camera for scale.

Figure 4.9

Brachina Creek emerges from a confined valley incised in the bedrock of the pediment, some 3 kilometres from its upland gorge mouth. Thence the Creek divides into two braided streams, Brachina Creek (left) and Brachina Overflow (right), which are entrenched in their own alluvial fan deposits.



Figure 4.10

The piedmont landform assemblage immediately north of Brachina Creek.

(a) Vertical air photograph.

(Aerial Photography, Survey 2501/031, 1979, Department of Environment and Natural Resources, South Australia)



Figure 4.10

The piedmont landform assemblage immediately north of Brachina Creek.

(b) Diagram of (a), where letters indicate main pediment (P), high pediment (hP), modern pediment (mP), riverine outwash plain (r/op), major alluvial fan (AF), minor alluvial fan (af) and incipient, or secondary, alluvial fans (f).

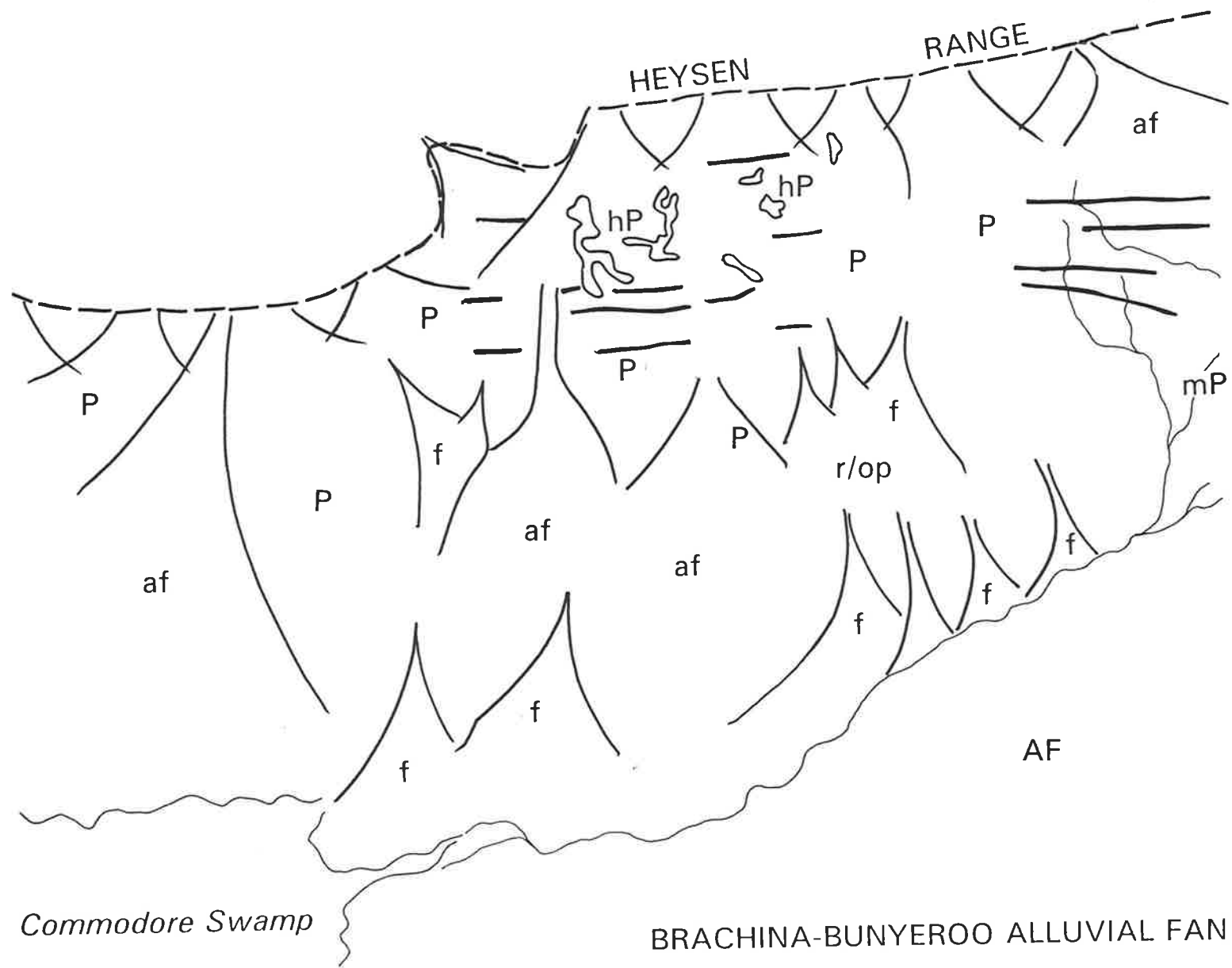


Figure 4.11

Coarse detritus comprises much of the deposit related to Ilina Creek North, the surface of which is very uneven due to the development of gilgai. The feature is morphologically a minor alluvial fan, although the catchment includes no argillite. Coarse alluvial deposits are banked behind a north-south structural ridge, which is parallel and 1200 metres west of the upland. A remnant of the covered pediment (right background) stands some 10 metres higher than the surface of the depositional feature.





Figure 4.12

Transverse profiles: Wyacca-Emeroo region, piedmont between Thompson and Deep creeks.

Source: 1:50 000 Topographic Series, map sheet, 6433-2 *Port Augusta*, Department of Environment and Natural Resources, South Australia.



## Figure 4.13

Angular material contributed to the upper parts of alluvial fans

(a) View across the 15 metre deep fanhead trench of the Wilkatana North Alluvial Fan to a large talus cone formed on the surface of the fan, immediately north of the gorge mouth.

(b) Streams of blocky detritus occur above the Deep Creek gorge cut through Emeroo Quartzite. Sorting by size is apparent in the rock screes (see also Figure 4.28).



#### Figure 4.14

Minor debris flow deposits included in the yellowish-red fluvial deposits of Wilkatana North Creek. Large boulder lying in younger, brown alluvium and above the debris flow material is approximately a metre in diameter.

#### Figure 4.15

Fluvial deposits, rather than debris flow deposits, are typical of fan conglomerates of the Wyacca-Emeroo region. Present channel of Deep Creek undercuts the southern bank to expose cut and fill deposits.



Figure 4.16

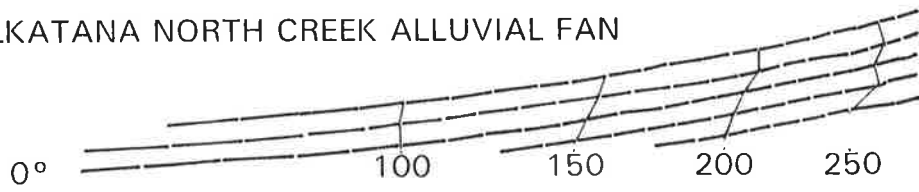
(a) Axis and azimuth profiles: Wyacca-Emeroo region. The line of axis determined by the orientation of the last one hundred metres of the main channel within the upland. The azimuth of any other radius chosen (e.g.  $22.5^\circ$  &  $45^\circ$ ) is measured as an angular distance from the axis (after Hooke & Rohrer, 1979).

(b) Location of profiles indicated on accompanying map.

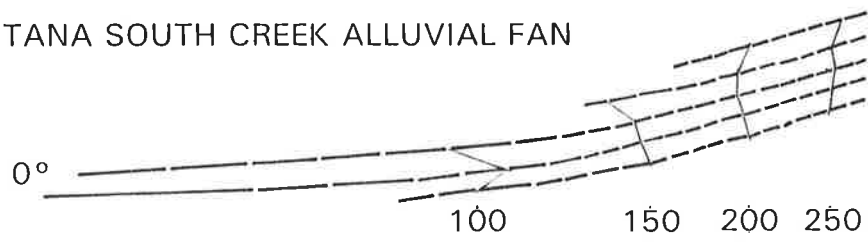
Source: 1:50 000 Topographic Series, map sheets 6433-1 *Wilkatana*, 6433-2 *Port Augusta*, Department of Environment and Natural Resources, South Australia.



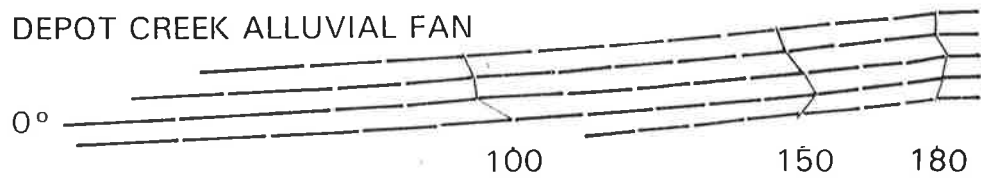
WILKATANA NORTH CREEK ALLUVIAL FAN



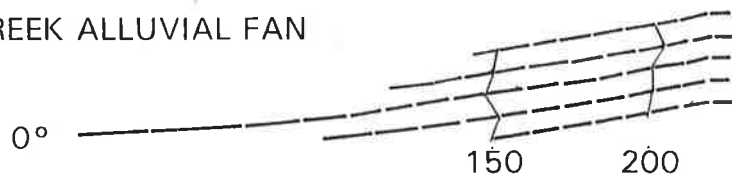
WILKATANA SOUTH CREEK ALLUVIAL FAN



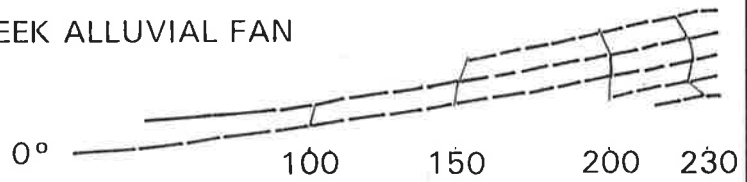
DEPOT CREEK ALLUVIAL FAN



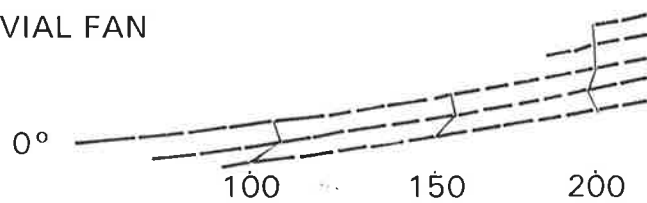
THOMPSON CREEK ALLUVIAL FAN



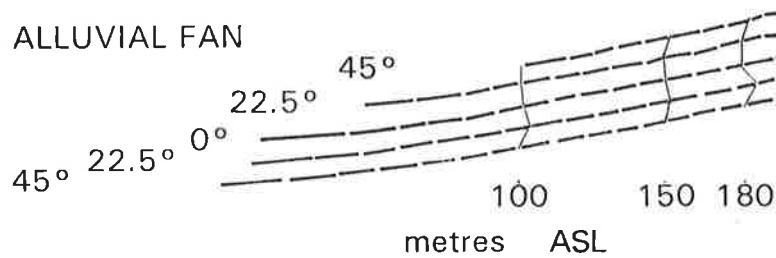
DRY SOUTH CREEK ALLUVIAL FAN



SOUTH CREEK ALLUVIAL FAN



DEEP CREEK ALLUVIAL FAN



AXIS & AZIMUTH PROFILES: WYACCA-EMEROO REGION

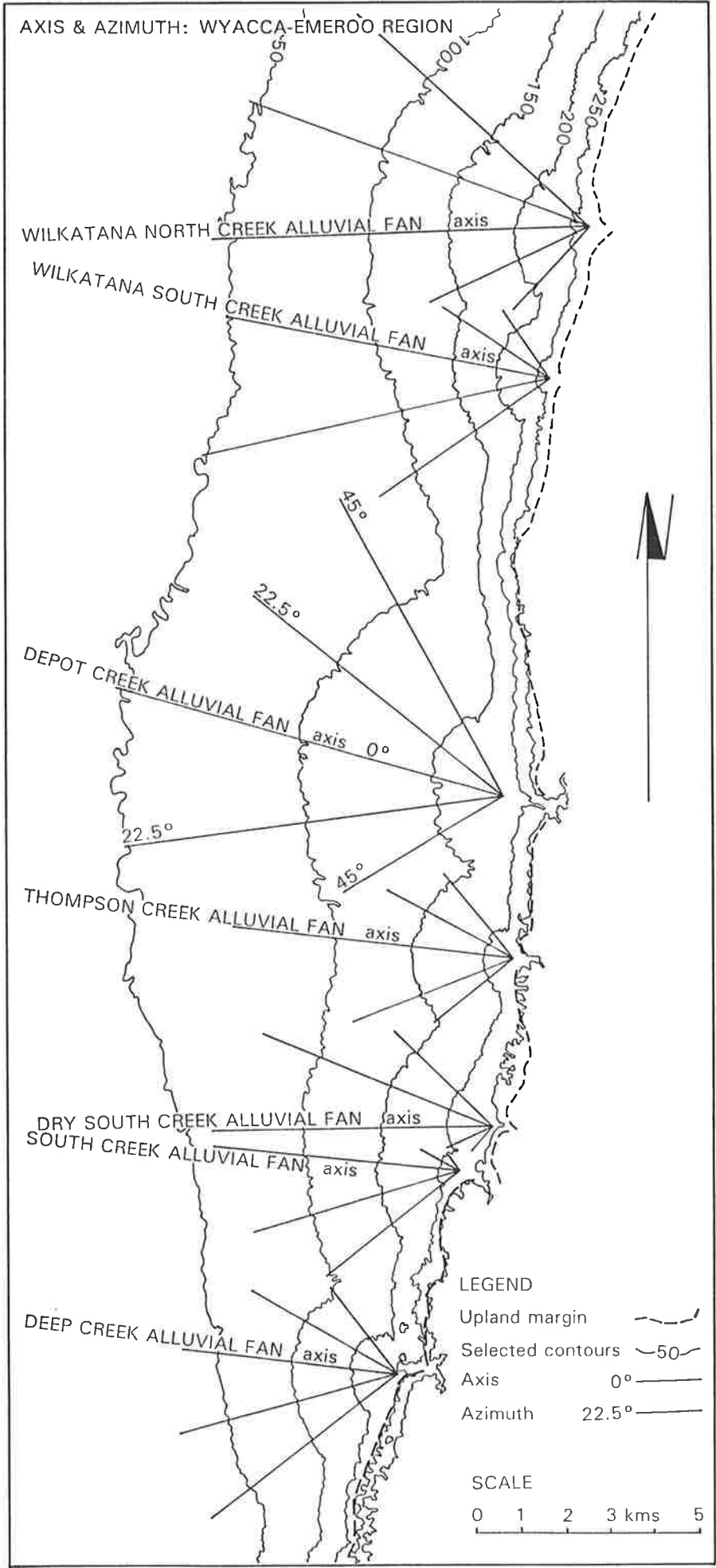
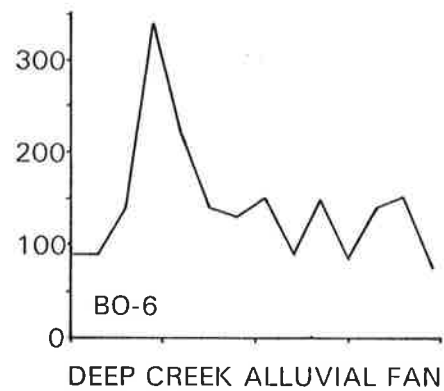
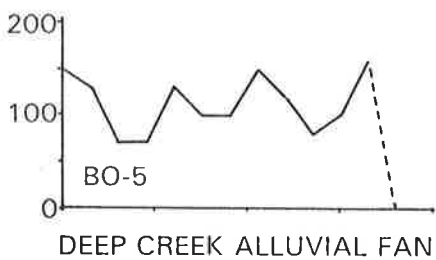
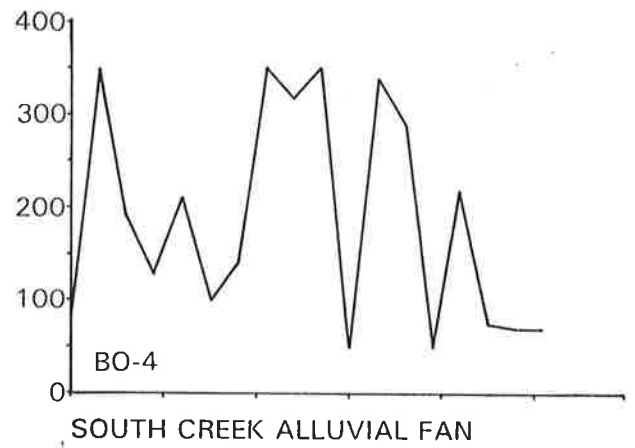
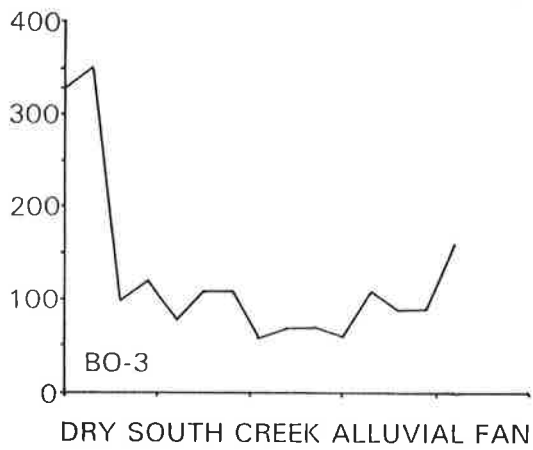
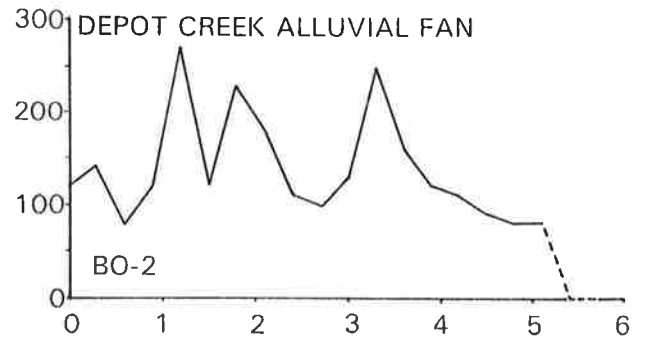
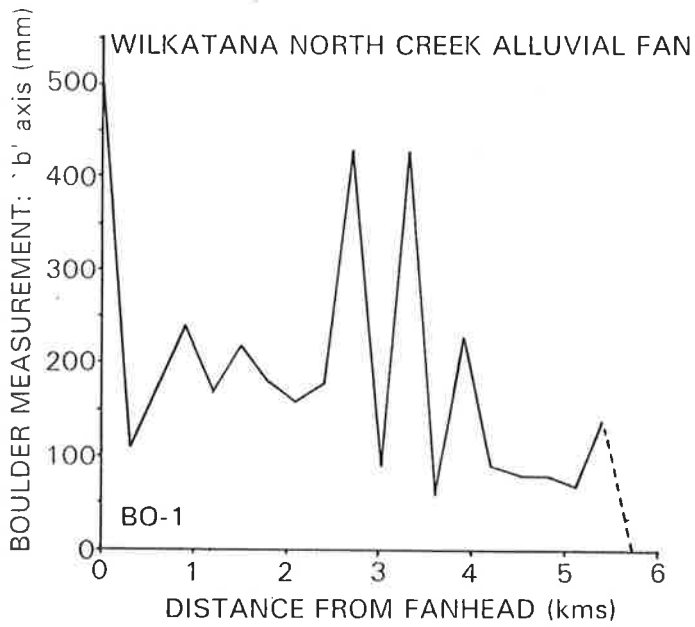


Figure 4.17

(a) Series of boulder measurements taken in the Wyacca-Emeroo piedmont. Three axial measurements, rock type, degree of roundness and setting were recorded (see Appendix V). Measurement of the 'b' axis of each boulder is graphed against distance from fanhead for the six traverses of the major alluvial fans of the region. A decrease in size of sample down the fan slope is apparent.

(b) Location of boulder measurement sites indicated on accompanying map. Sites also shown on each traverse, where soil sampled for X-Ray Diffraction analysis.

Source: 1:50 000 Topographic Series, map sheets 6433-1 *Wilkatana*, 6433-2 *Port Augusta*, Department of Environment and Natural Resources, South Australia.



BOULDER MEASUREMENT GRAPHS: WYACCA-EMEROO REGION

BOULDER & SOIL SAMPLE SITES: WYACCA-EMEROO REGION

WILKATANA NORTH CREEK ALLUVIAL FAN

WILKATANA SOUTH CREEK ALLUVIAL FAN

DEPOT CREEK ALLUVIAL FAN

THOMPSON CREEK ALLUVIAL FAN

DRY SOUTH CREEK ALLUVIAL FAN

SOUTH CREEK ALLUVIAL FAN

DEEP CREEK ALLUVIAL FAN

BO-1

965-620

965-61

965-600

BO-2

965-59

965-570

965-580

BO-3

965-55

965-56

BO-4

965-54

965-53

BO-5

965-51

BO-6

965-52

LEGEND

Selected contours ~100

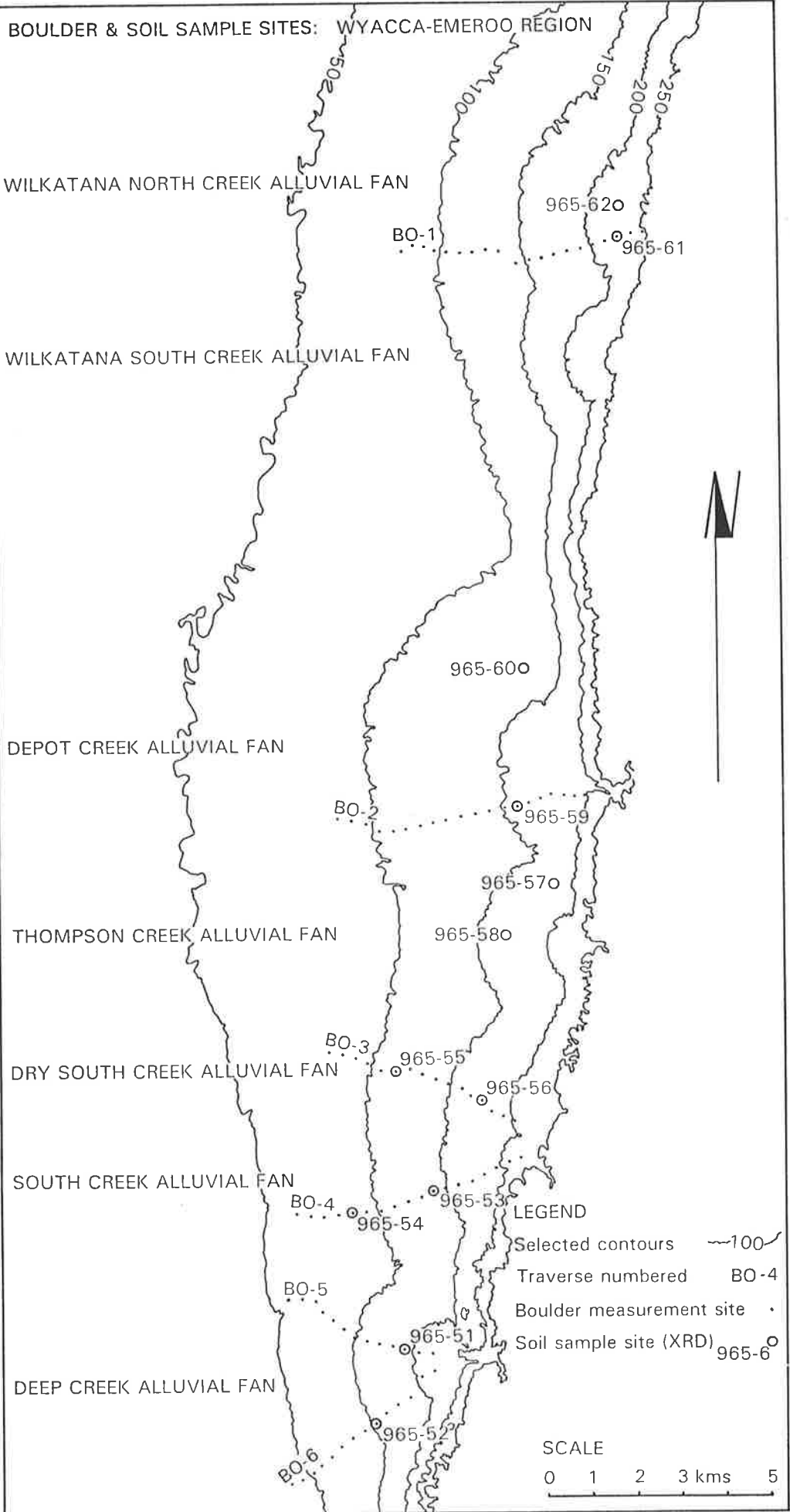
Traverse numbered BO-4

Boulder measurement site ·

Soil sample site (XRD) 965-6

SCALE

0 1 2 3 kms 5



## Figure 4.18

In the Wyacca-Emeroo region Deep Creek has deposited a major alluvial fan (Figure 3.2).

Deep Creek is incised at the southern margin of the pediment embayment and flows directly westwards and normal to the range front in a 500 metre long fanhead trench before emerging at the intersection point (I P) and depositing its sediment load (see also Figure 4.19b). Some 30 years ago, after heavy rains, Deep Creek choked its axis channel with sediment and was diverted into several channels flowing southwest over the southern half of the fan (J. Brook, pers. comm., 1992).

Bar and channel topography (B & C) in brown-dark-brown alluvium occurs in the fanhead trench, which is eroded in older yellowish-red alluvium. North of the fan axis gilgai is developed in the yellowish-red alluvium of the main or upper level of the alluvial fan (U). The surface of Deep Creek Alluvial Fan south of the Creek, some 2 metres above the bars and channels of the braided main stream, is of bar and pavement topography (B & P) in brown-dark brown alluvium. Note that streams incised in this part of the fan develop meanders. Some of the minor distributary streams, on the flanks of the lower fan area, tend to meander (m), probably reflecting lower discharges through finer sediment. Many minor streams, with dendritic drainage patterns and no more than one metre deep, erode the toeslopes of the alluvial fan.

(Aerial Photography, Survey 4316/080, 1991, Department of Environment and Natural Resources, South Australia)

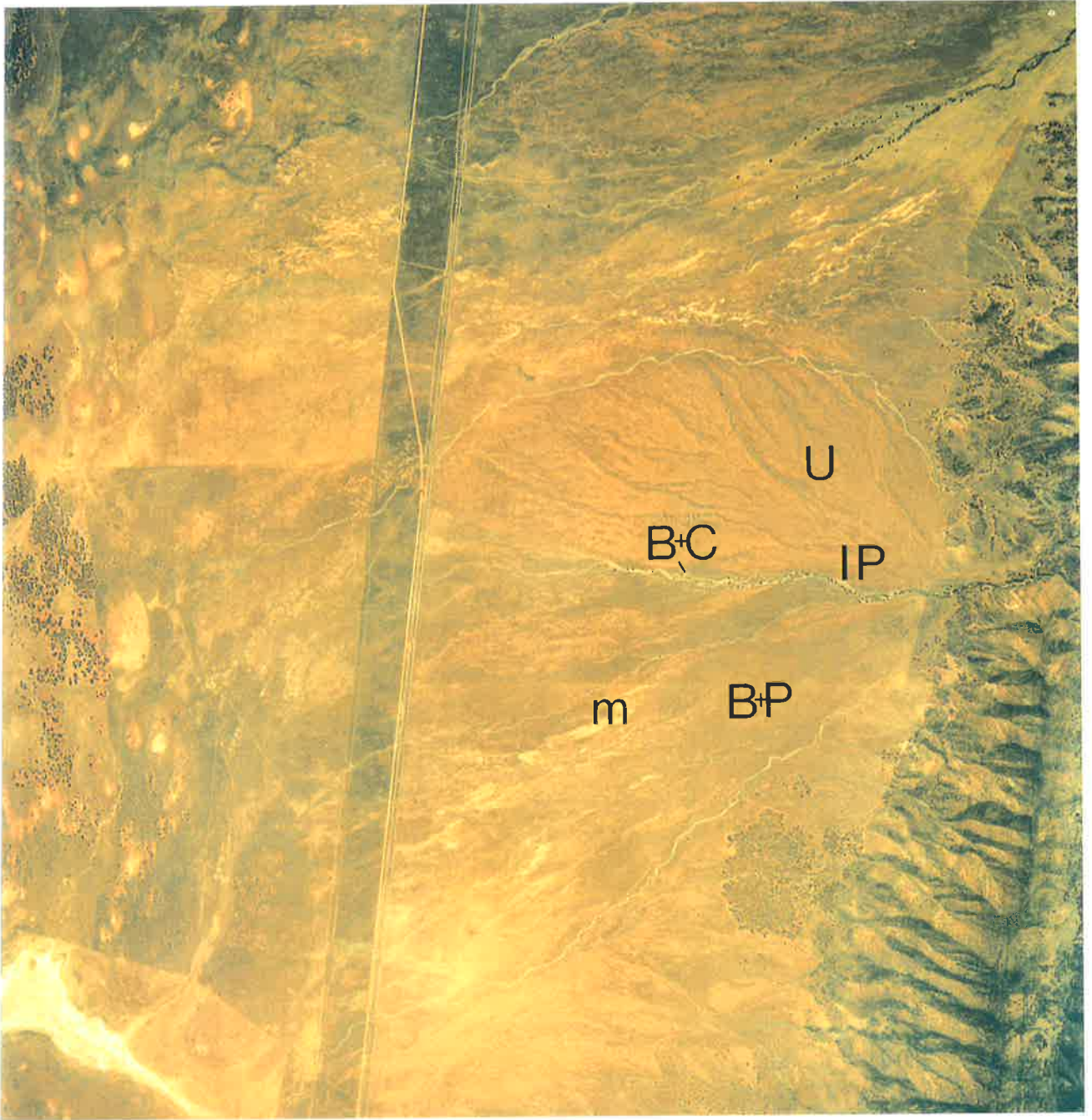


Figure 4.19

#### Intersection points

(a) Thompson Creek emerges from a confined 6-10 metres deep channel about one kilometre from the fanhead. Formlines indicate that the stream has deposited sediment below the intersection point. Site of Figure 4.22a (C0), 3m red alluvial cliff (C1), coloured section this Figure (C2), 1-2m red cliff (C3), 2m brown cliff (C4), <1m red cliff (C5).

Source: Aerial Photography, Survey 4316/005, 1991, Department of Environment and Natural Resources, South Australia.

(b) Deep Creek is associated with a similar pattern of fanhead incision and deposition of alluvium below the intersection point some 500 metres from the fan apex (see also Figure 4.18). Cliffs 4m red (C0), 3-4m red (C1), 2m red (C2), 1-2m red (C3).

Source: Aerial Photography, Survey 4316/080, 1991, Department of Environment and Natural Resources, South Australia.



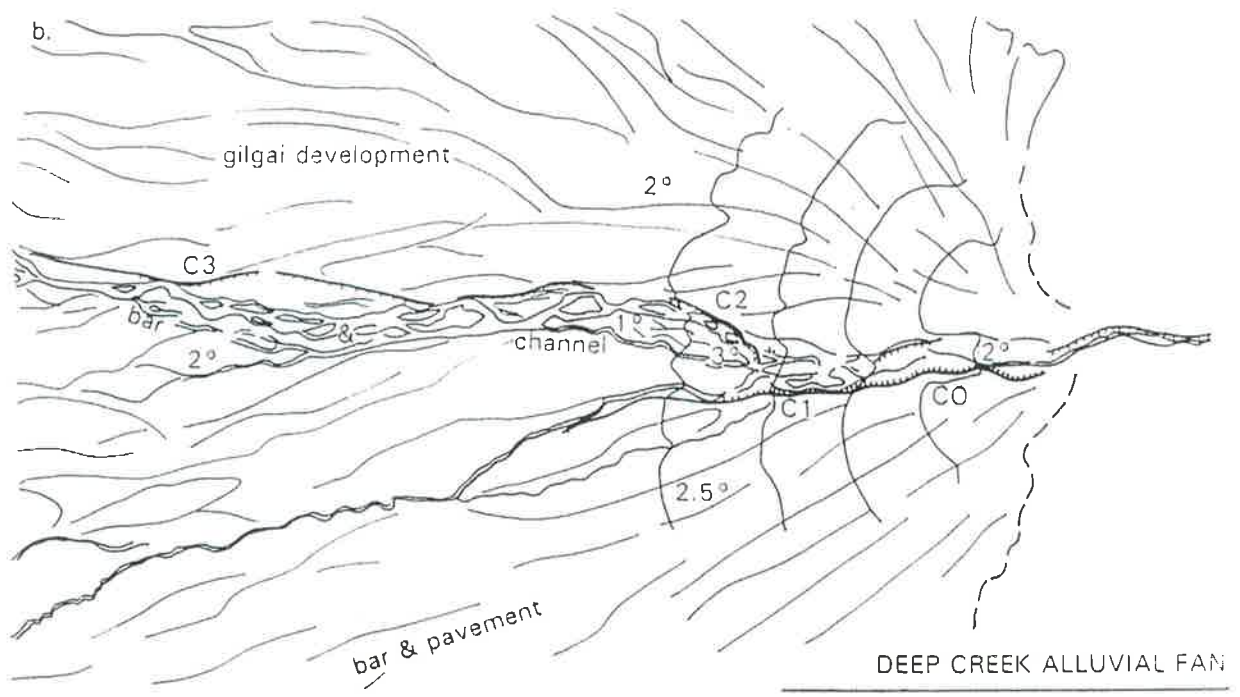
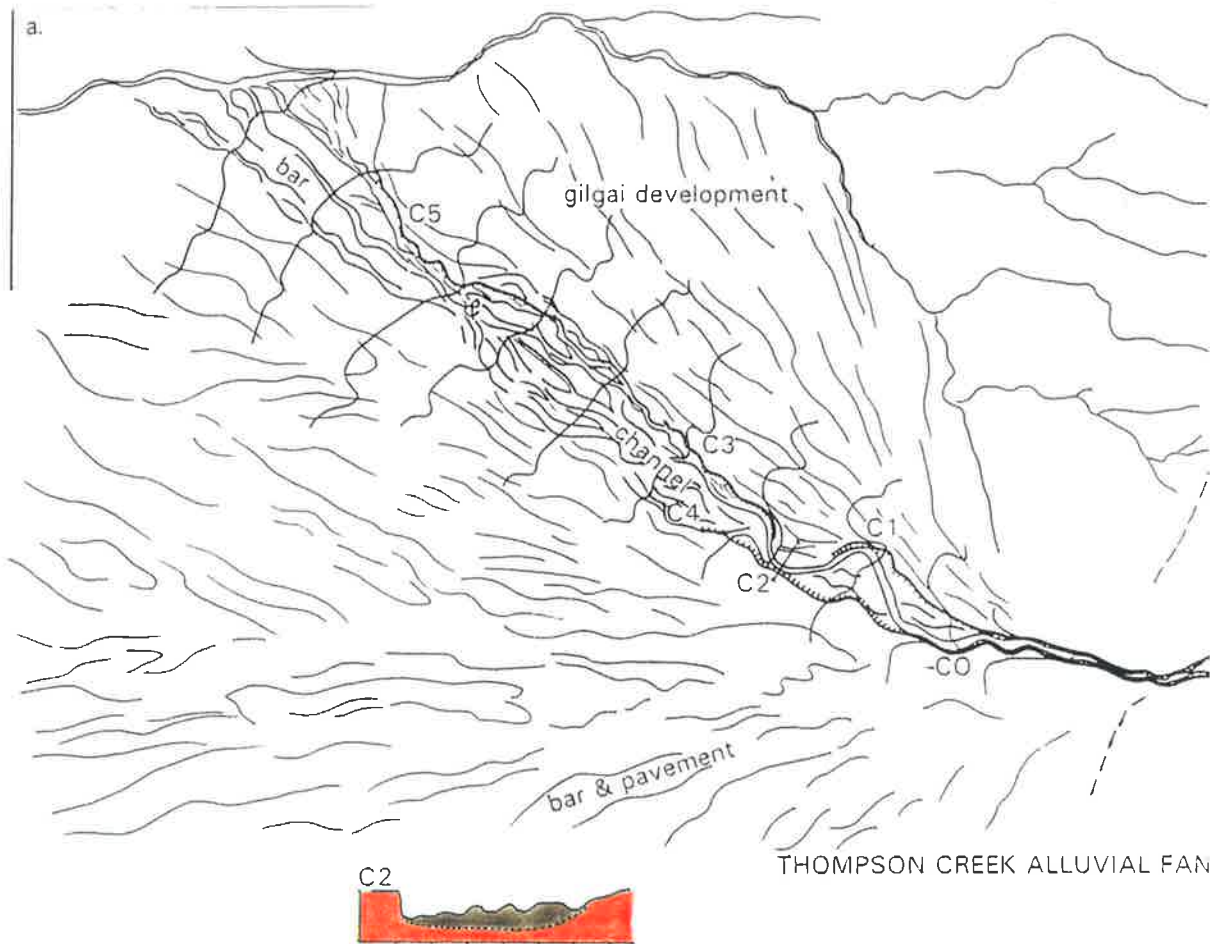


Figure 4.20

Bar and pavement topography of Dry South Creek Alluvial Fan.



## Figure 4.21

Diagrammatic cross sections, based on field sketches, show stratigraphic relationship of younger (brown) over older (yellowish-red) alluvial deposits in the main channels of Dry South, Wilkatana North, Depot and Deep creeks (see also C2 *in* Figure 4.19a).

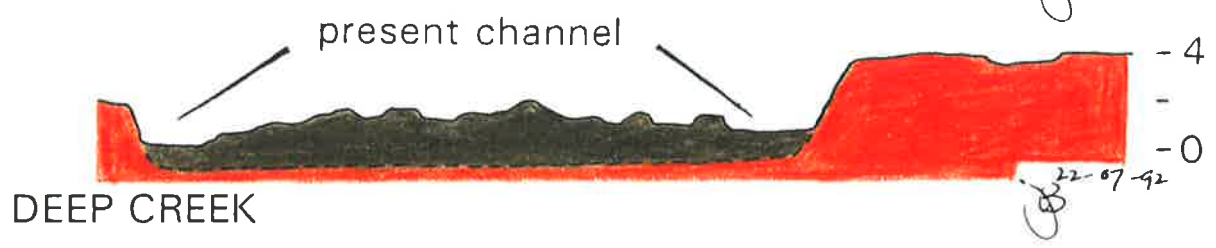
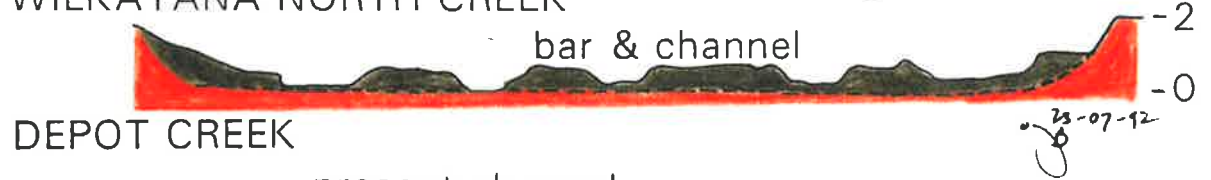
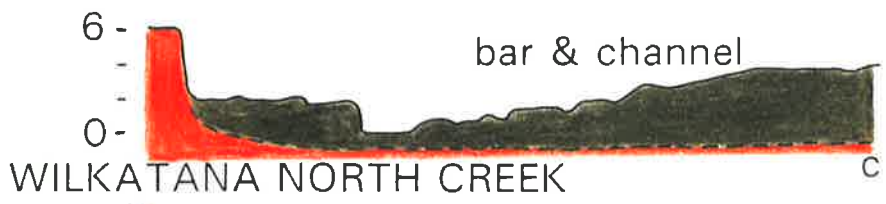
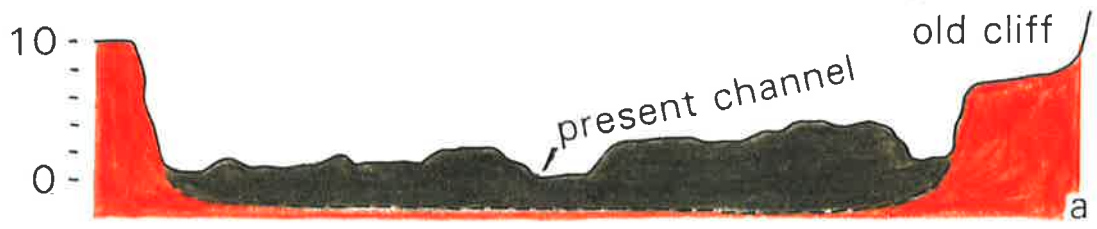
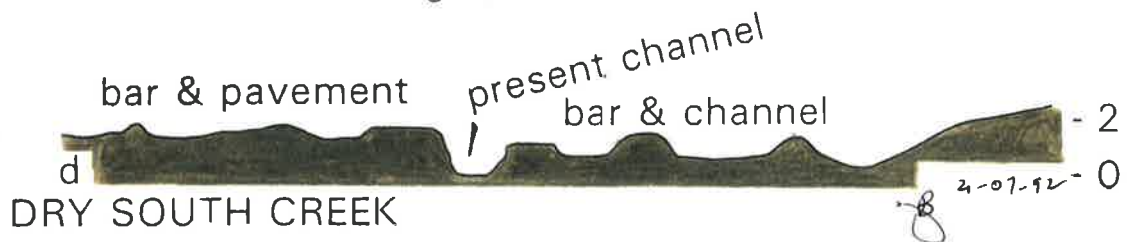
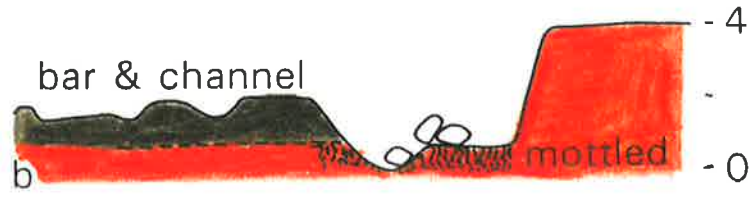
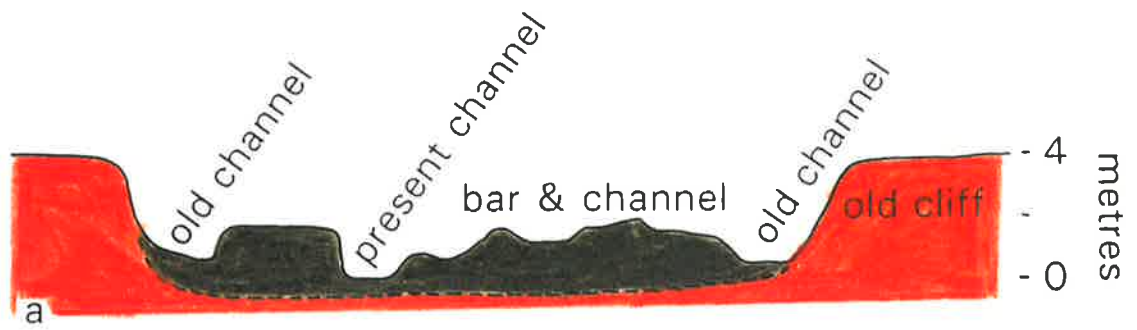


Figure 4.22

Younger (brown) over older (yellowish-red) alluvial deposits

(a) Thompson Creek erodes both younger and older alluvial deposits as it scours at the base of 4m cliff wall of the fanhead trench (see line of section and C2 *in* Figure 4.19a).

(b) Cut and fill feature is emphasised by the different coloured alluvial deposits in Wilkatana North Creek.

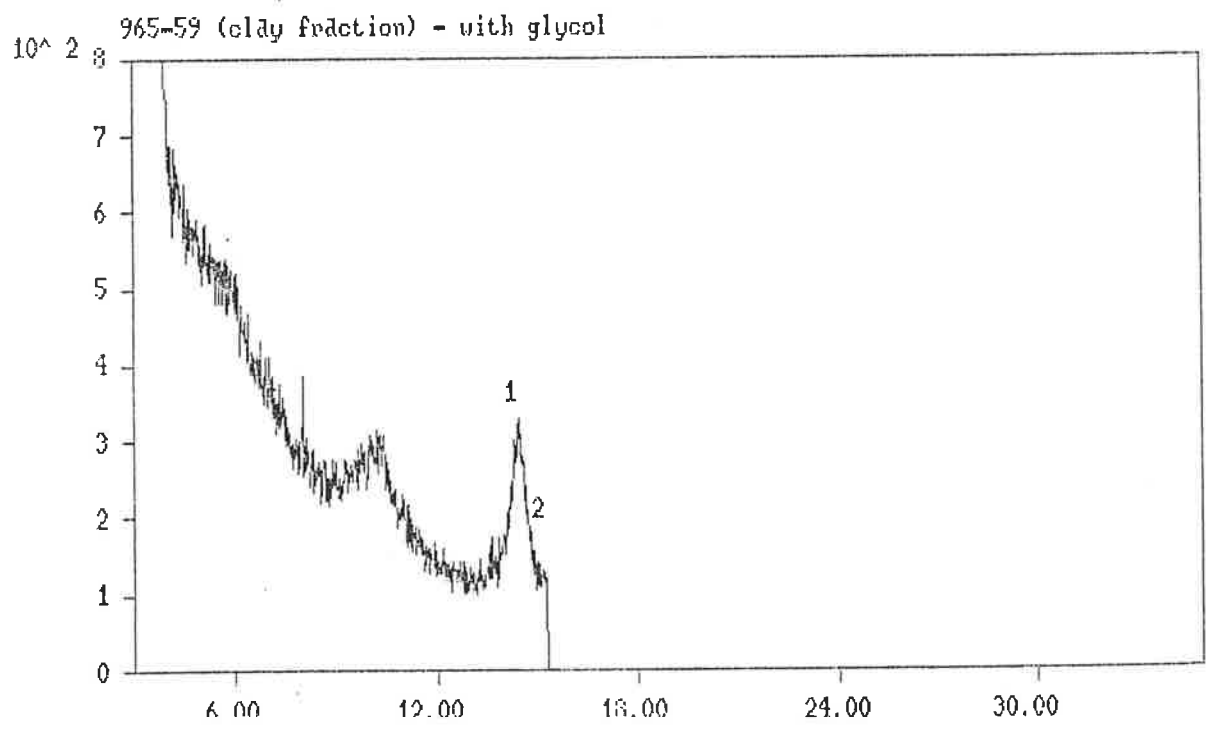
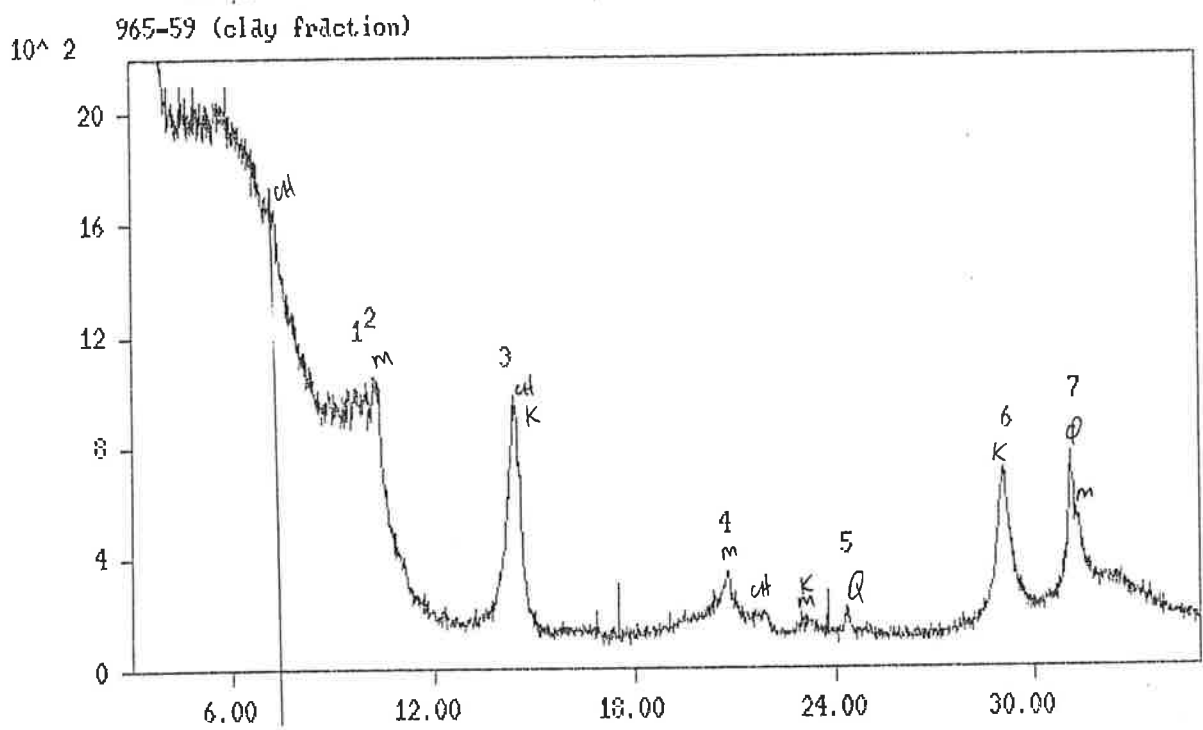
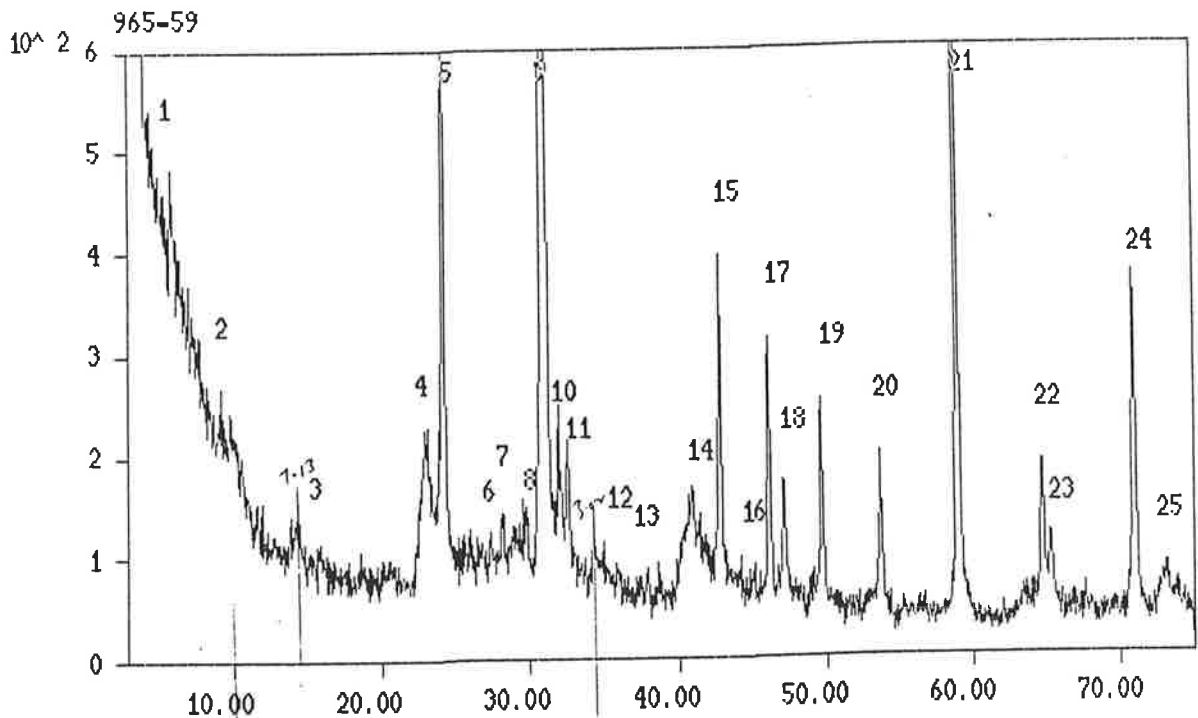


## Figure 4.23

Example of X-Ray Diffraction analyses of bulk, clay fraction and clay fraction with ethylene glycol added:

(a) Depot Creek soil sample 965-59, taken from the upper alluvial fan surface affected by gilgai development. The convexity in the graph at the lower end of the bulk sample trace and the occurrence of chlorite and kaolinite suggest the presence of smectite, or swelling clay. The clay fraction trace confirmed this. Ethylene glycol was added to the clay fraction sample to elucidate further the presence of smectite. See Figure 4.17b for site location and Appendix VI for all data.



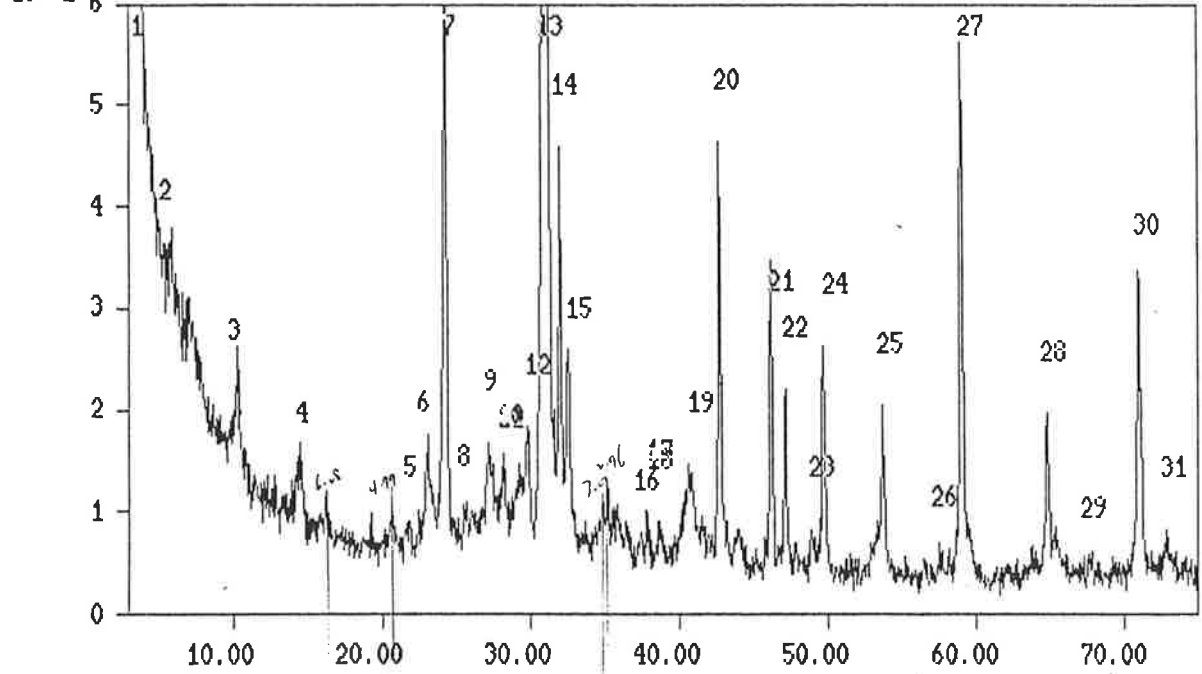


## Figure 4.23

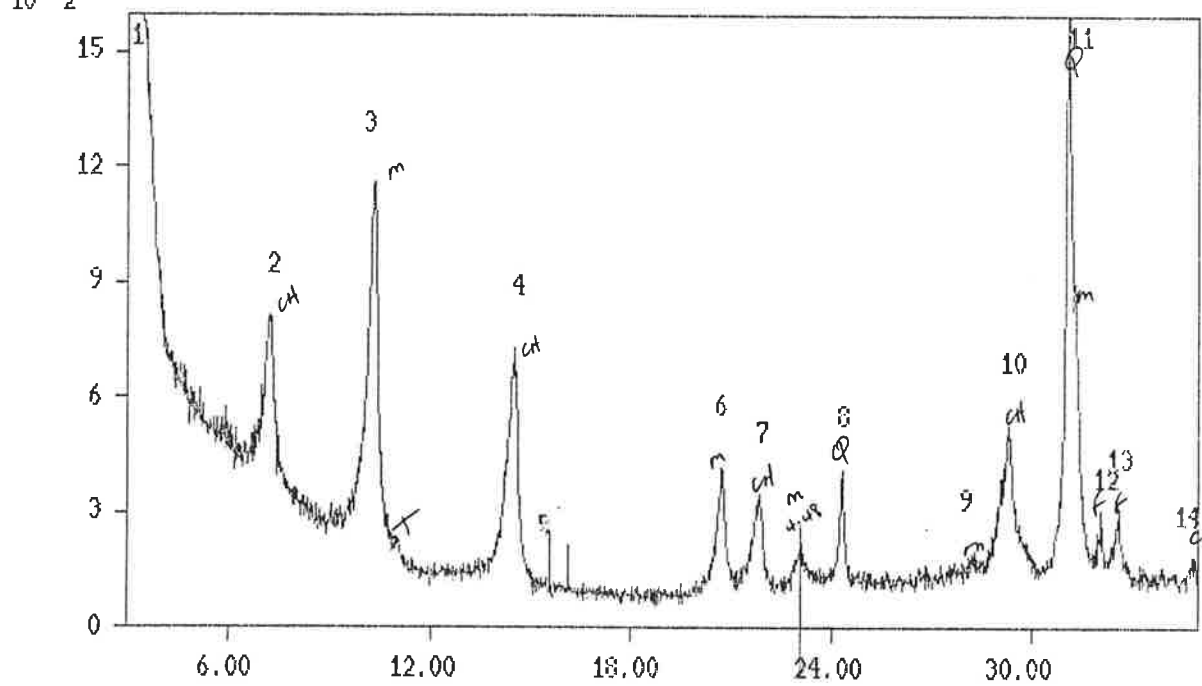
Example of X-Ray Diffraction analyses of bulk, clay fraction and clay fraction with ethylene glycol samples:

(b) Dry South Creek soil sample 965-56, was taken from the bar and pavement surface of the alluvial fan. The bulk sample and clay fraction traces are smoothly curved. Chlorite is present, but not kaolinite. Smectite is not present. See Figure 4.17b for site location and Appendix VI for all data.

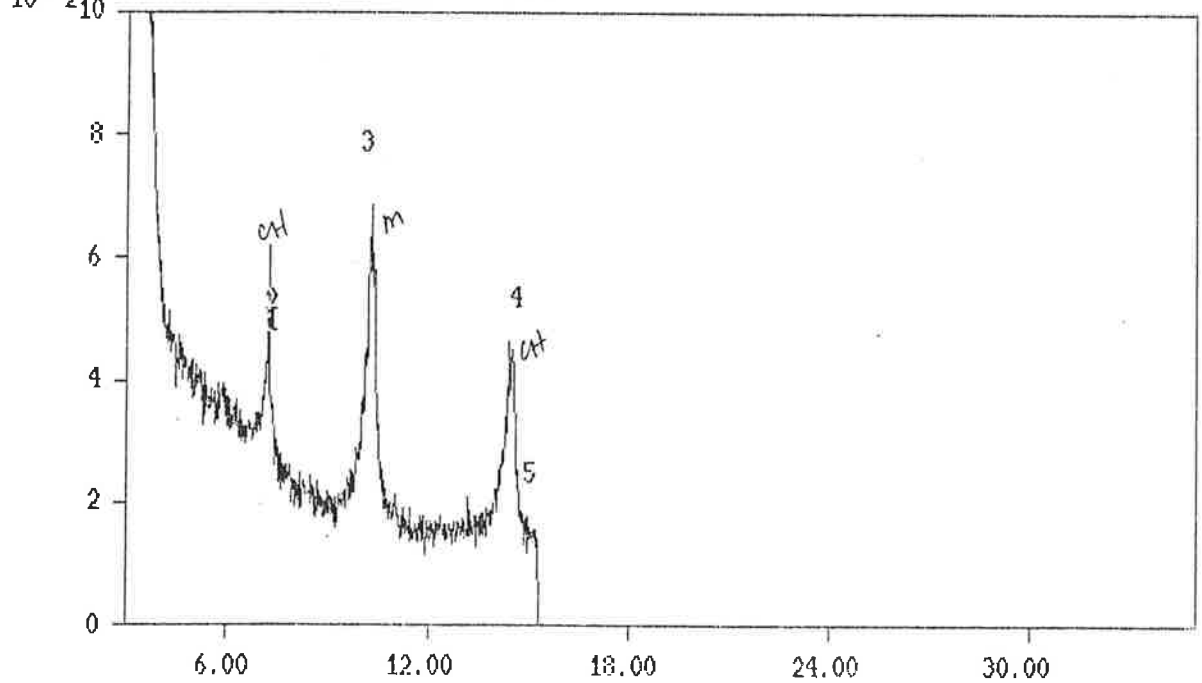
965-56



965-56 (clay fraction)



965-56 (clay fraction) - with glycol



#### Figure 4.24

The resolution of the nominally 3.55Å peak into two peaks, for example, on the clay fraction trace for the Deep Creek soil sample 965.52, is diagnostic of the presence of both chlorite and kaolinite (see Table 4.7). Chlorite indicates that swelling clay (smectite) may be present. See Figure 4.17b for site location and Appendix VI for all data.

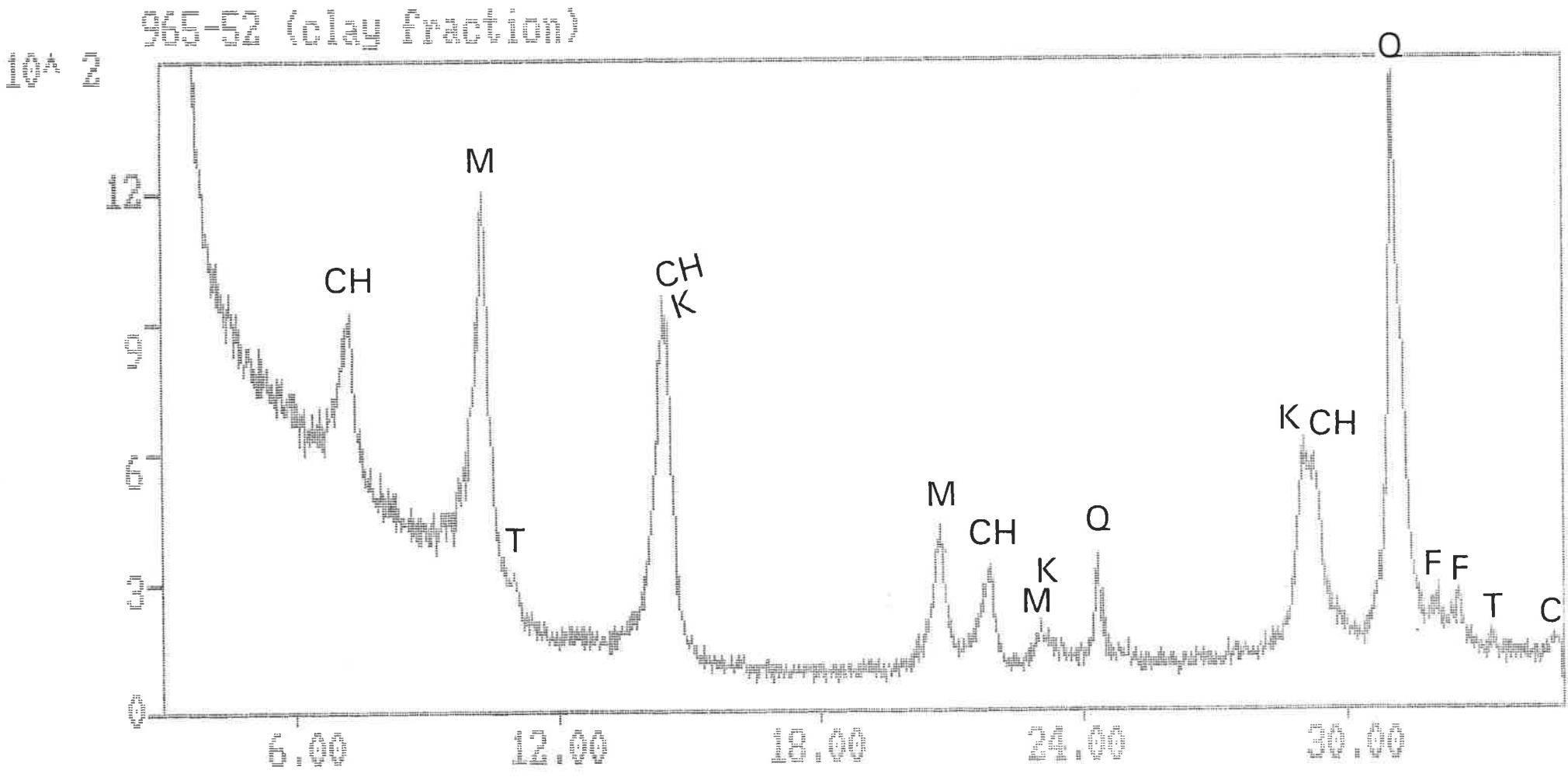


Figure 4.25

Drainage basins of the major alluvial fans: Wyacca-Emeroo region.

Source: 1:50 000 Topographic Series, map sheets 6433-1 *Wilkatana*, 6433-2 *Port Augusta*,  
Department of Environment and Natural Resources, South Australia.

**DRAINAGE BASINS: MAJOR ALLUVIAL FANS**  
**WYACCA-EMEREO REGION**

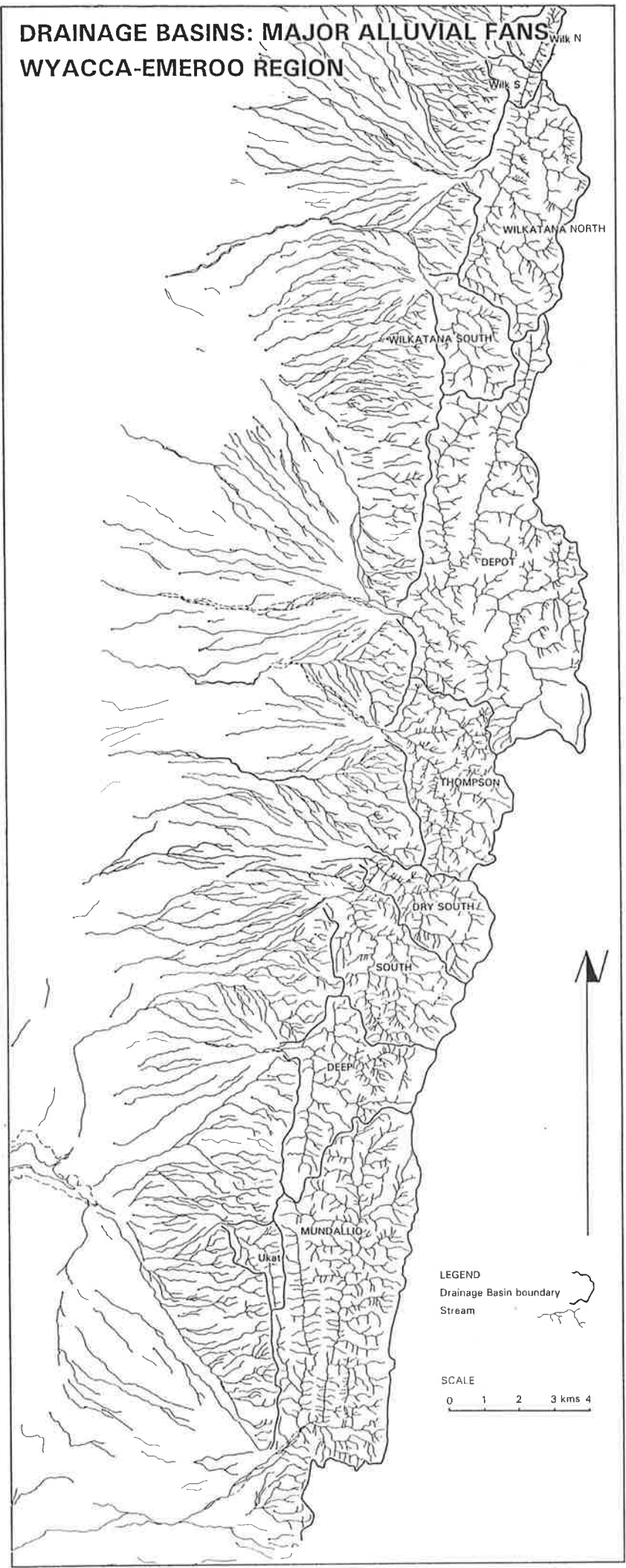


Figure 4.26

Deep Creek drainage basin

(a) Geology (Dalgarno *et al.*, 1968).

LEGEND

1. A.B.C. Range Quartzite
2. Willochra Formation, upper unit (sandstone/siltstone)
3. Willochra Formation, upper unit (calcareous siltstone)
4. Tapley Hill Formation (calcareous siltstone)
5. Appila Tillite
6. Unnamed (dolomitic shale)
7. Skillogalee Dolomite
8. Rhynie Sandstone/Emeroo Quartzite.

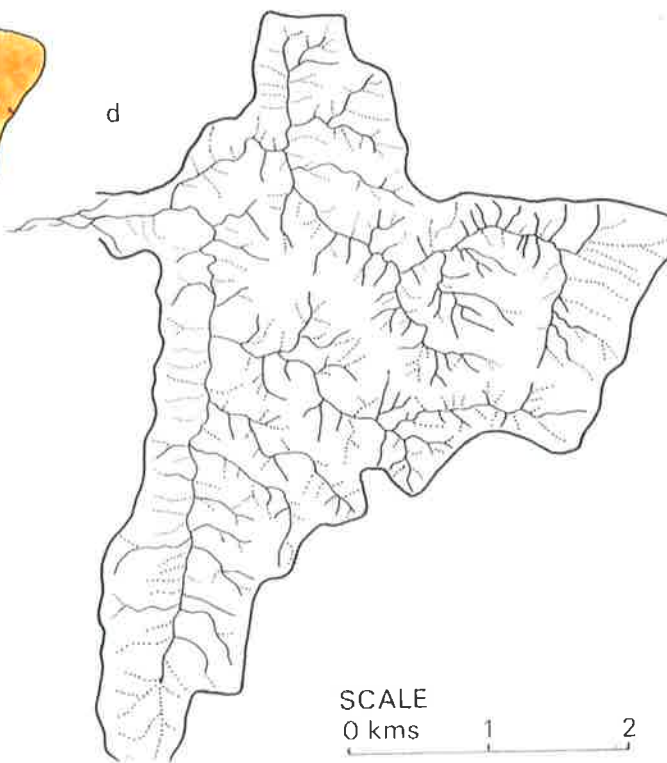
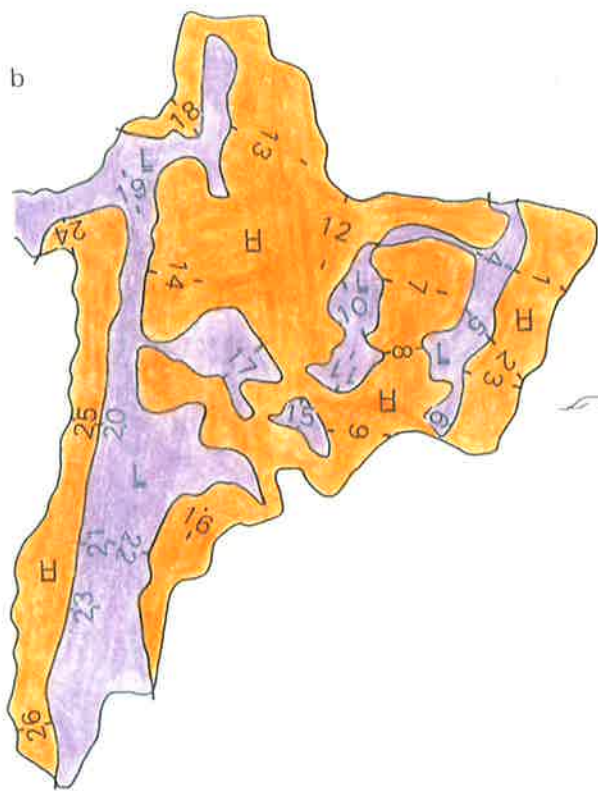
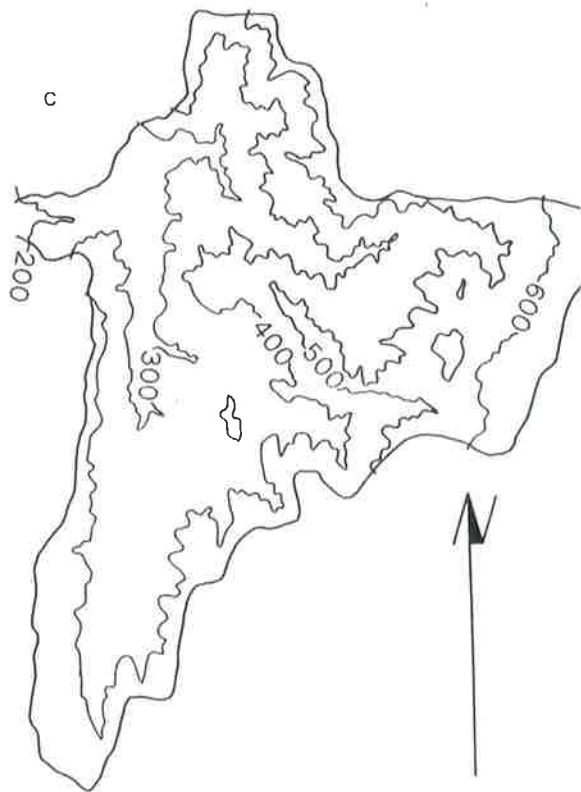
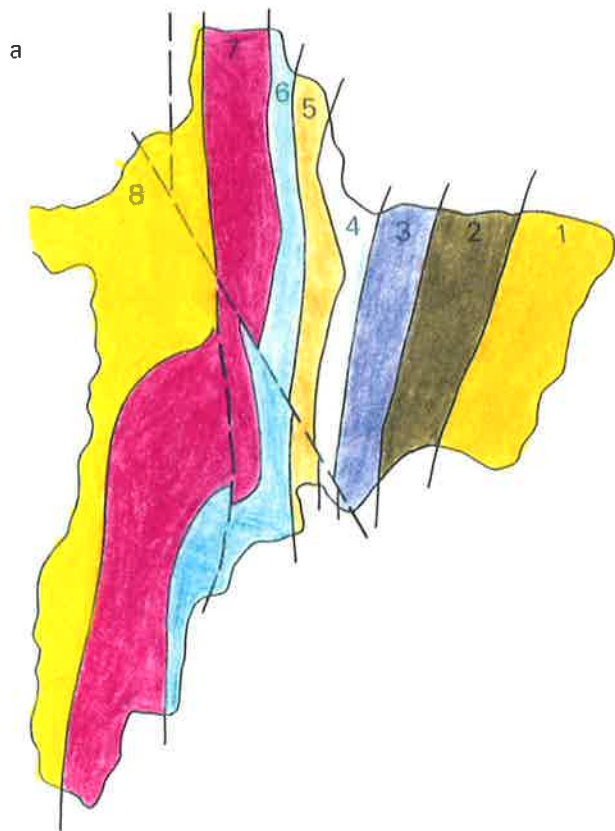
(b) Percentage slope (after Strahler, 1952) is related to rock type shown in (a). H valley-side slopes vary from 0.27-0.68, L valley-side slopes vary 0.08-0.24. See Table 4.9 for measurements of the 26 valley-side slope segments marked on this map.

(c) Catchment zoned according to height above present sea level. On the eastern perimeter some 5% of the catchment is higher than 600 metres, 49% of the basin area occurs between between 600 and 400 metres, the remainder (46%) lies between 400 metres and 200 metres above present sea level at which point Deep Creek emerges from the upland.

Source: 1:50 000 Topographic Series, map sheet 6433-2 *Port Augusta*, Department of Environment and Natural Resources, South Australia.

(d) Drainage Network: 'blue-line' network (continuous stream lines) includes perennial and intermittent streams with well-defined permanent channels, in the judgement of the mapping authority, whereas contour crenulations indicate all sites where channel flow has occurred (dotted stream lines) (after Kennedy, 1978).





SCALE  
0 kms 1 2

Figure 4.27

Sediment is readily available in the Deep Creek catchment, for example:

(a) in minor alluvial terraces

(b) dammed behind bedrock bars

(c) talus cones.

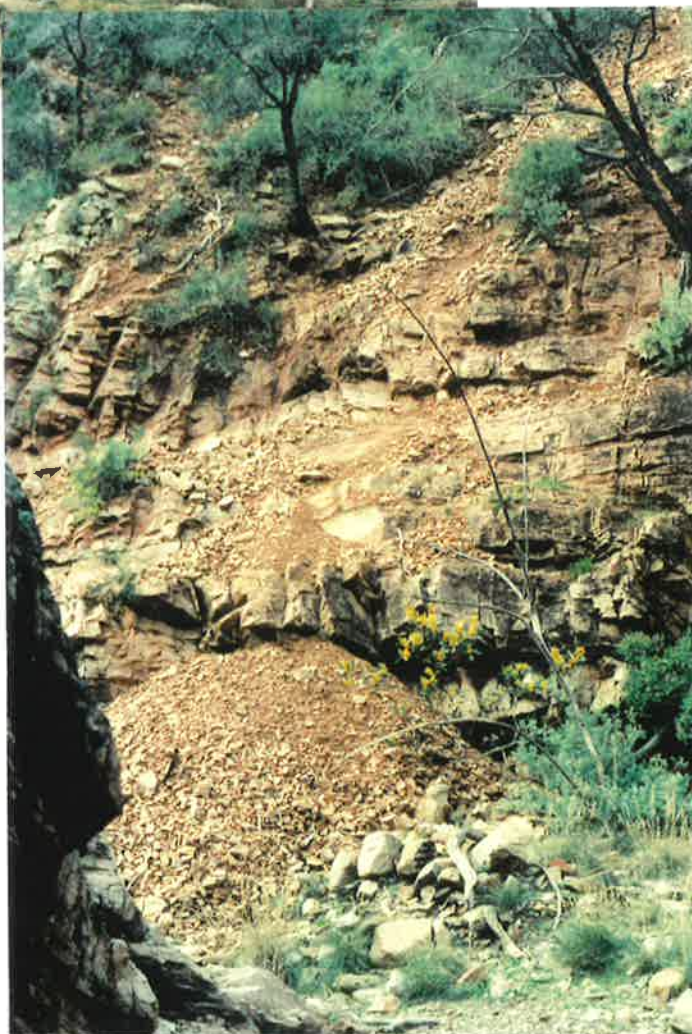
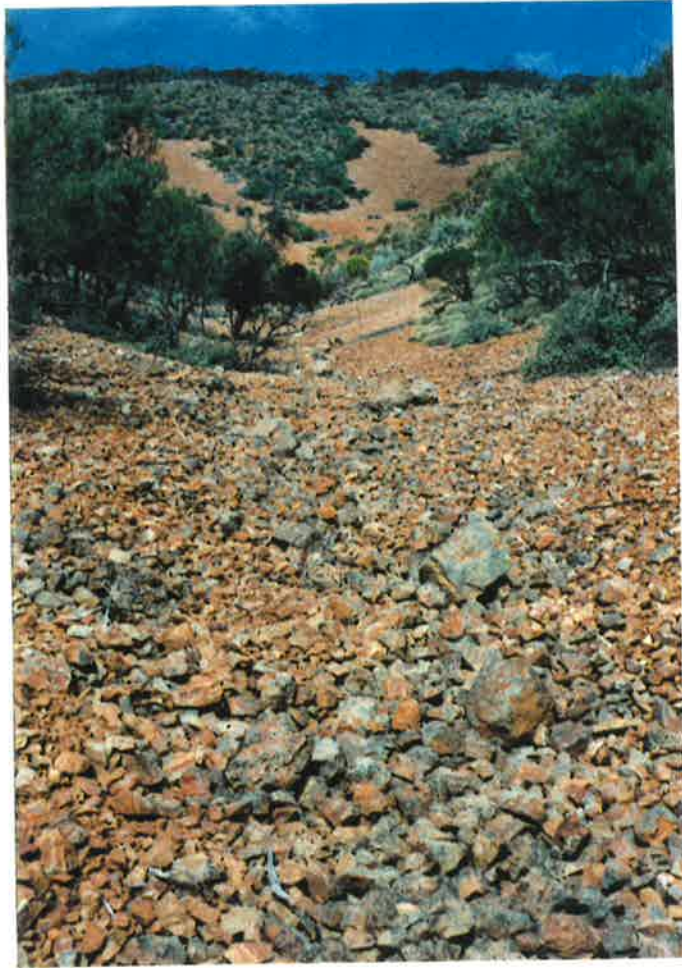


Figure 4.28

Rock screes on quartzitic upland slopes south of Wilkatana North Creek gorge. Blocky detritus, typically 15-25cm in diameter, rests on the slopes and sides of channels. Lichens grow on the exposed surfaces of larger rock fragments, 45-100cm, which lie in the bottom of channels and lower areas of the scree slopes.

Figure 4.29

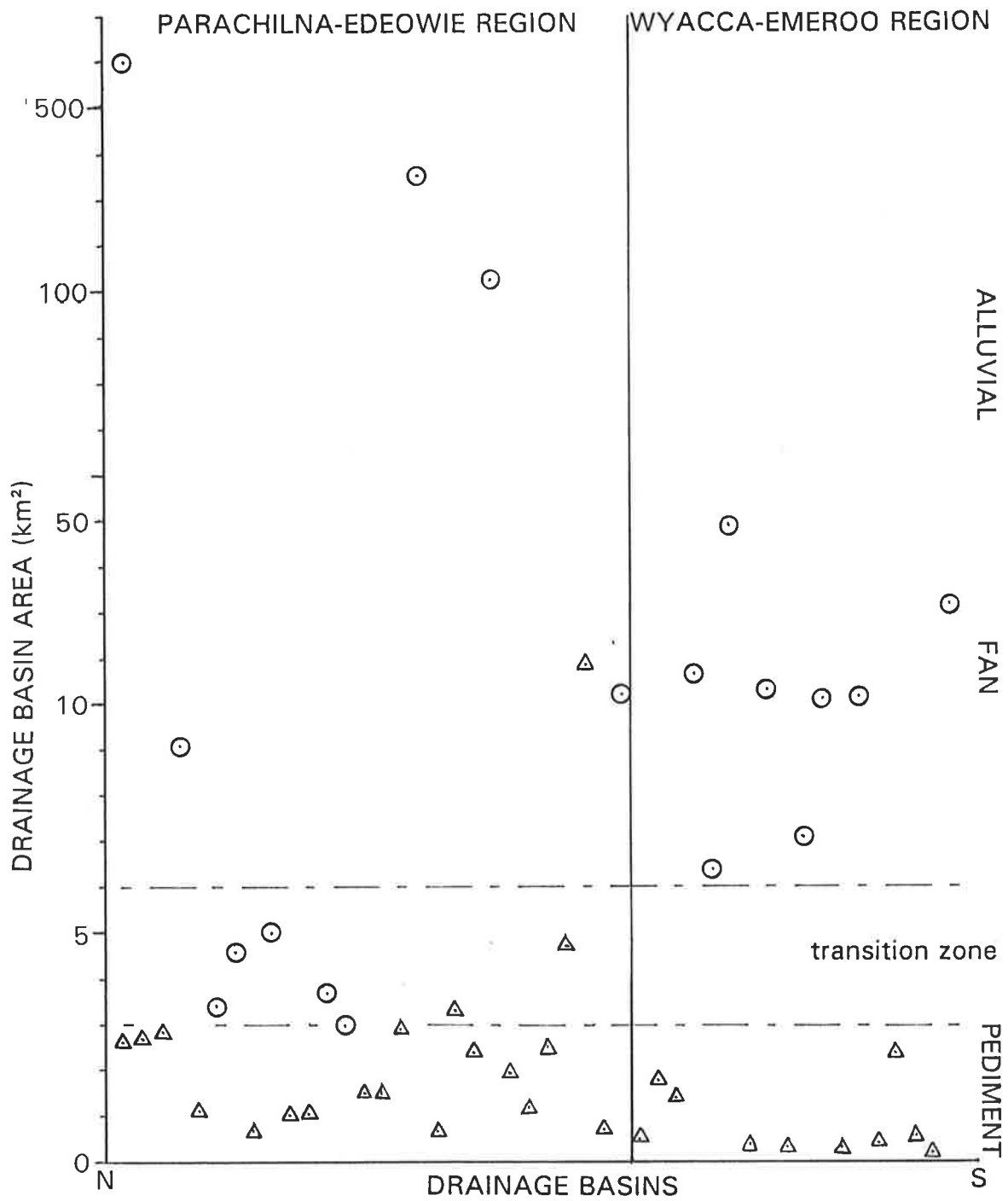
Minor alluvial fan deposited on the pediment surface in the scarp foot immediately south of South Creek. The stream has eroded a shallow channel (centre and left) in the alluvial fan sediments.



## Figure 5.1

Graph illustrates that catchments are critical to understanding the distribution of pediments and alluvial fans in the study area.

Drainage basins confined to the western rampart of the Flinders Ranges are characterised by outcrops of resistant strata which, on weathering, produce coarse detritus. These catchments are less than 3 square kilometres in area and are associated with pediments (see Chapter Three). On the other hand, major alluvial fans are related to drainage basins that are more than 6 square kilometres in area and are dominated by argillite (see Chapter Four). The piedmont landforms which occur in the 'transition zone', i.e. drainage basins larger than  $3\text{km}^2$  and smaller than  $6\text{km}^2$ , are associated with riverine outwash plains, where the catchment is eroded in resistant strata, and minor alluvial fans, where the catchment includes argillite. The riverine outwash plain associated with Edeowie Creek is exceptional (see Chapters Three & Five for description and discussion).

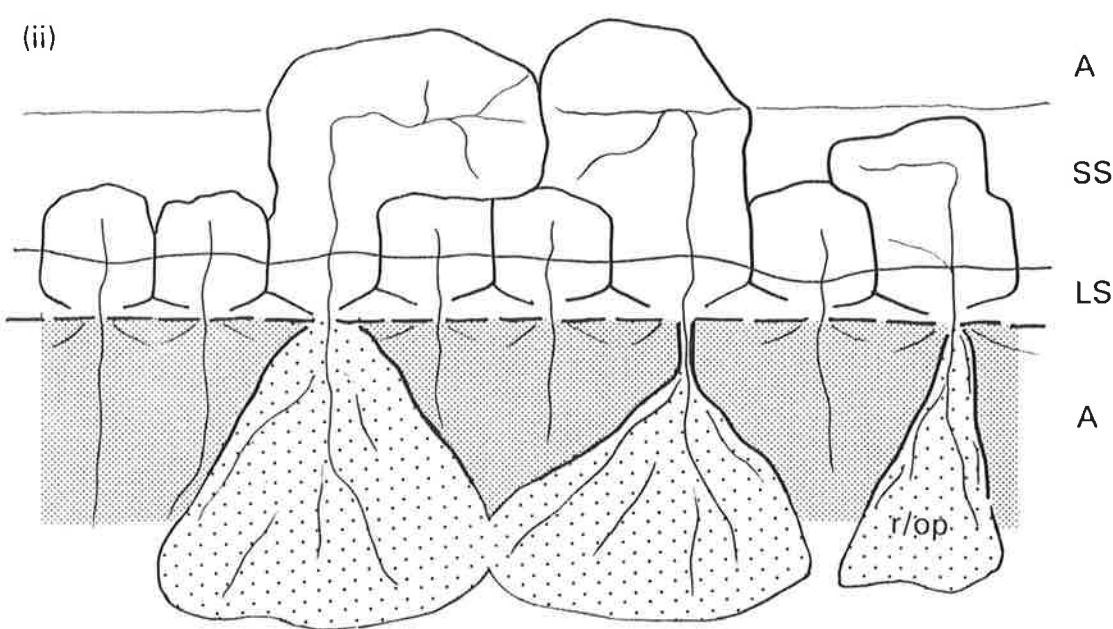
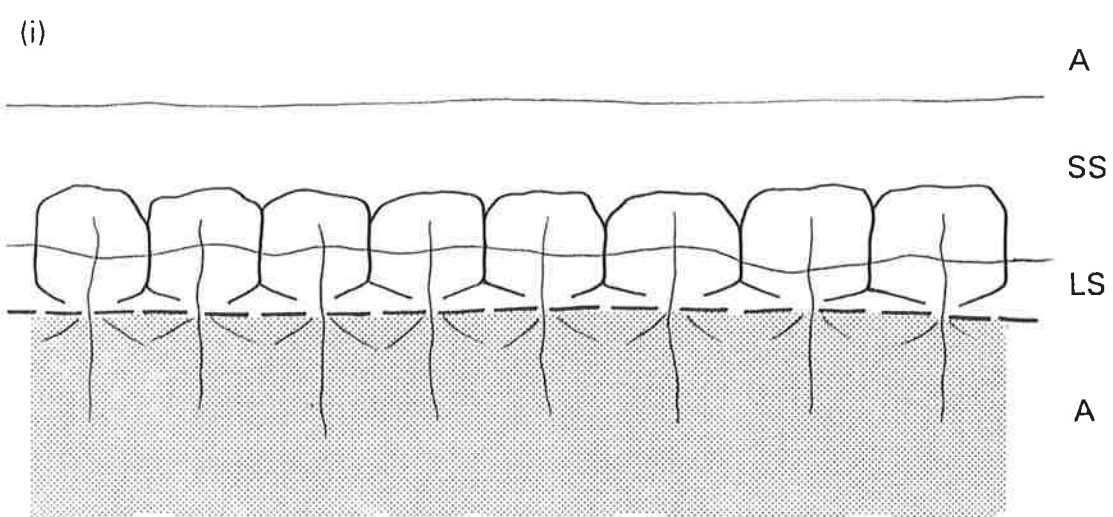


- △ quartzite sandstone/limestone
- plus shale siltstone

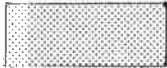


Figure 5.2

Diagram of evolutionary sequence suggested for the development of pediments and alluvial fans.





LEGEND

- |   |          |   |                        |
|---|----------|---|------------------------|
|  | pediment |  | alluvial fan           |
| A = argillite   |          |  | riverine outwash plain |
| SS = sandstone  |          |   |                        |
| LS = limestone  |          |   |                        |

EVOLUTIONARY SEQUENCE PEDIMENT TO ALLUVIAL FAN

Figure 5.3

Pediment replaced by distal, lateral and headward growth of alluvial fan

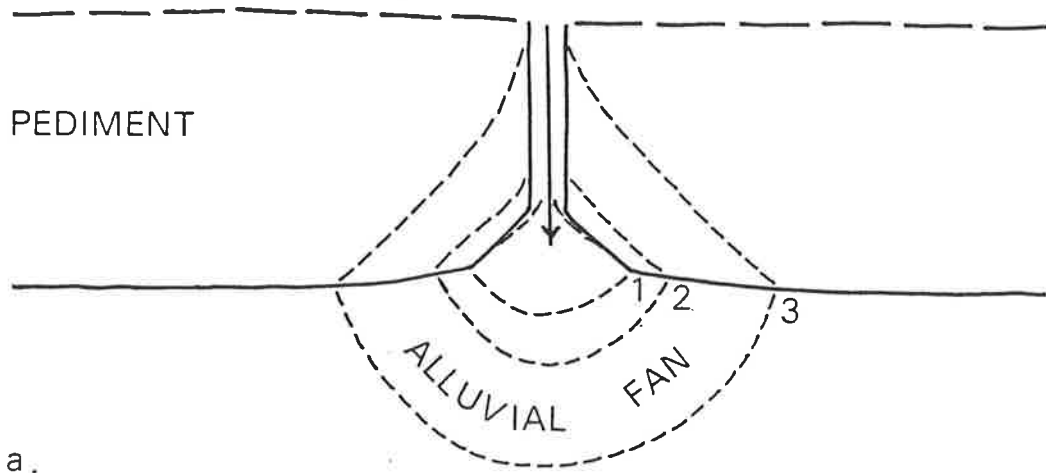
(a) in plan view

(b) in cross section

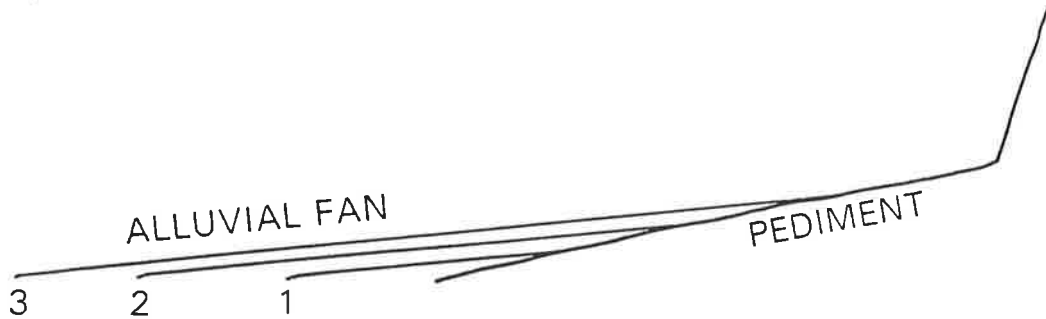
(c) calculation, and its geometrical expression, for the Parachilna-Edeowie region, where pediments typically slope  $3^\circ$  and alluvial fans  $0.33^\circ$

(d) calculation, and its geometrical expression, for Wyacca-Emeroo region, where pediments typically slope  $4^\circ$  and alluvial fans  $2^\circ$ .

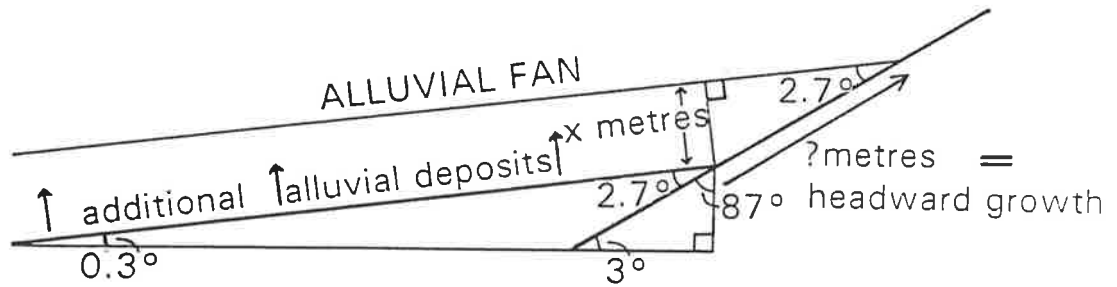
# ALLUVIAL FAN REGRESSION / HEADWARD GROWTH



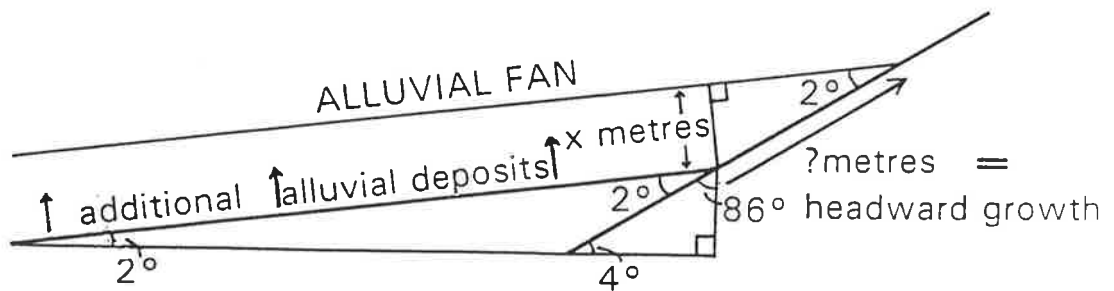
a.



b.



c. PARACHILNA-EDEOWIE REGION



d. WYACCA-EMEROO REGION

#### Figure 5.4

Vertical air photographs of the braided channels of Brachina Creek and Brachina Overflow. Scale approximately 1:40 000. Minimal changes to the pattern of bars and channels have occurred between 1958 and 1992. The most obvious changes are in size of the occasional tree growing in the beds of the streams.

(Aerial Photography, Survey 277/9466, 1958, & Survey 4245/116, 1990, Department of Environment and Natural Resources, South Australia).



Figure 5.5 (MAP POCKET)

Morphology and geology maps of Aliena Washout and environs

Source: Aerial Photography, Survey 4236, 1990, Department of Environment and Natural Resources, South Australia; Dalgarno & Johnson, 1966.

## Figure 5.6

- (a) A rock pediment, or rock fan, forms part of the upper slopes of Aliena Washout.
- (b) The fissile and brittle nature of the bedrock exposed in the rock pediment surface of Aliena Washout.

## Figure 5.7

Gullying, some 5 metres deep, by Wobma Creek and its tributaries in the western footslopes of Aliena Washout, in part follows the straight line of a former roadway. Alluvial fan deposits exposed in the walls of the Creek include about 3 metres of silty sand sheets, thin (2cm) mudflows and occasional lenses of pebbles over a layer of cobbles, at least 2 metres thick.





Figure 5.8

Remnants of rock pediment associated with Pettana Creek. Pettana Creek is a strike stream draining a catchment located at the northern end of Wyacca Range. Covered pediments (P) slope gently ( $3^\circ$ ) away from the uplands on either side of the valley. Several rock pediment remnants (rP) occur near the axis of the valley. Further north the covered pediment surface merges with alluvial fan deposits (F).

(Drawn from Aerial Photography, Survey 2696/047, 1981, Department of Environment and Natural Resources, South Australia).

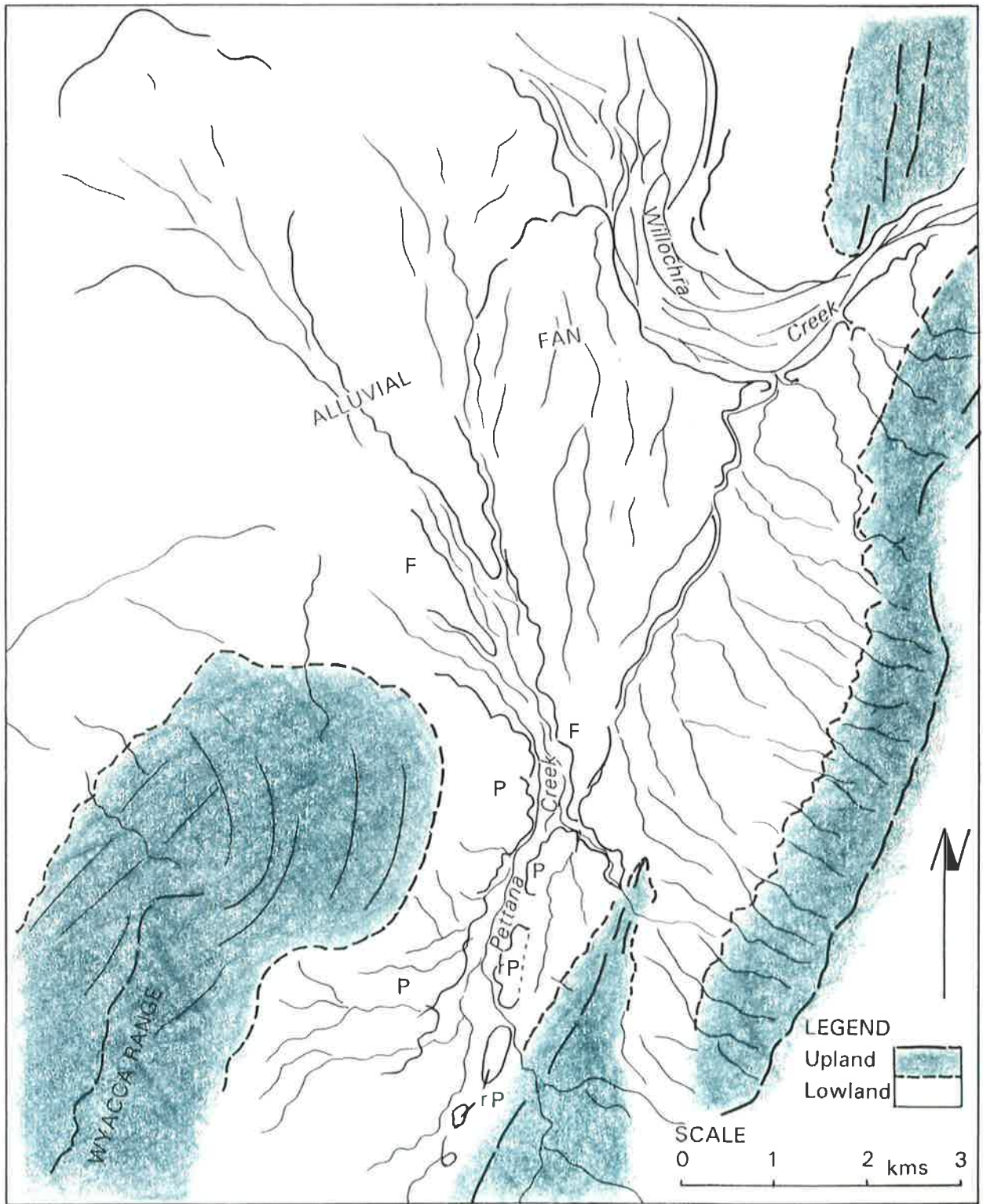


Figure AI.1

(a) Satellite image centred on the Parachilna Gorge, Parachilna-Edeowie region (see also Figure 4.7). Colour banding indicates the lithology of the folded sequence of the upland, e.g. green (visible red) for Brachina Formation, minimal red areas indicate sparse vegetation, west-facing slopes are in shadow, and light blue (visible blue and green) shows the pattern of streams and tracks. Within the piedmont, the Parachilna Alluvial Fan is readily distinguished from the covered pediment slopes south of the gorge mouth, but comparable with the minor alluvial fan associated with Five Mile Creek. Note the effects of fencing and watering points on the Parachilna Alluvial Fan surface.

BAND	COLOUR GUN	DATA LIMITS	STRETCH
WITHIN HISTOGRAM			
1 Visible Blue	Blue	40-126	Gaussian Equalise
3 Visible Red	Green	10- 90	Gaussian Equalise
7 mid I/Red	Red	2-105	Gaussian Equalise

(b) Image centred south of the mouth of Parachilna Gorge. Colour variations for the pediment surface and the minor alluvial fan associated with Five Mile Creek, noted in Figure AI.1a, enhanced with by applying different band ratios.

BAND	COLOUR GUN	DATA LIMITS	STRETCH
WITHIN HISTOGRAM			
<u>3 Visible Red</u> 1 Visible Blue	Blue	0.24-1.07	Histogram Equalise
<u>7 mid I/Red</u> 1 Visible Blue	Green	0.15-1.11	Histogram Equalise
<u>7 mid I/Red</u> 4 near I/Red	Red	0.48-1.18	Histogram Equalise

Source: Landsat 5 Thematic Mapper imagery using the ERMAPPER software package on SUN SPARC, Station 2.



Figure AI.2

(a) Satellite imagery centred on Wilkatana North and South alluvial fans in the Wyacca-Emeroo region. Colours are similar to those of Figure AI.1a, but a greater proportion of the alluvial fans have a sparsely vegetated, stony surface with few active channels (mustard yellow), compared with the lower, more active parts of the fans (purple/light blue). Narrow fringing pediment remnants lie at the foot of the Wyacca Range with a thin alluvial cover, mostly sandstone from the scarp behind (mustard yellow and mid-green). Dark and red/brown areas, in the upland, interfan areas, and secondary fans on the distal slopes of the major fans, indicate the wetter conditions in this more southerly region. Swamps and salinas occur within the Torrens Plain dunefield.

BAND	COLOUR GUN	DATA LIMITS	STRETCH
WITHIN HISTOGRAM			
1 Visible Blue	Blue	38-107	Gaussian Equalise
3 Visible Red	Green	9- 81	Gaussian Equalise
7 mid I/Red	Red	1- 74	Gaussian Equalise

(b) Image enhanced with different band ratios. In particular active (upper surface) and inactive areas (bar, pavement and channel surface) of the alluvial fan surfaces are defined.

BAND	COLOUR GUN	DATA LIMITS	STRETCH
WITHIN HISTOGRAM			
<u>3 Visible Red</u> 1 Visible Blue	Blue	0.11-1.17	Histogram Equalise
<u>7 mid I/Red</u> 1 Visible Blue	Green	0.01-1.38	Histogram Equalise
<u>7 mid I/Red</u> 4 near I/Red	Red	0.02-2.16	Histogram Equalise

Source: Landsat 5 Thematic Mapper imagery using the ERMAPPER software package on SUN SPARC, Station 2.

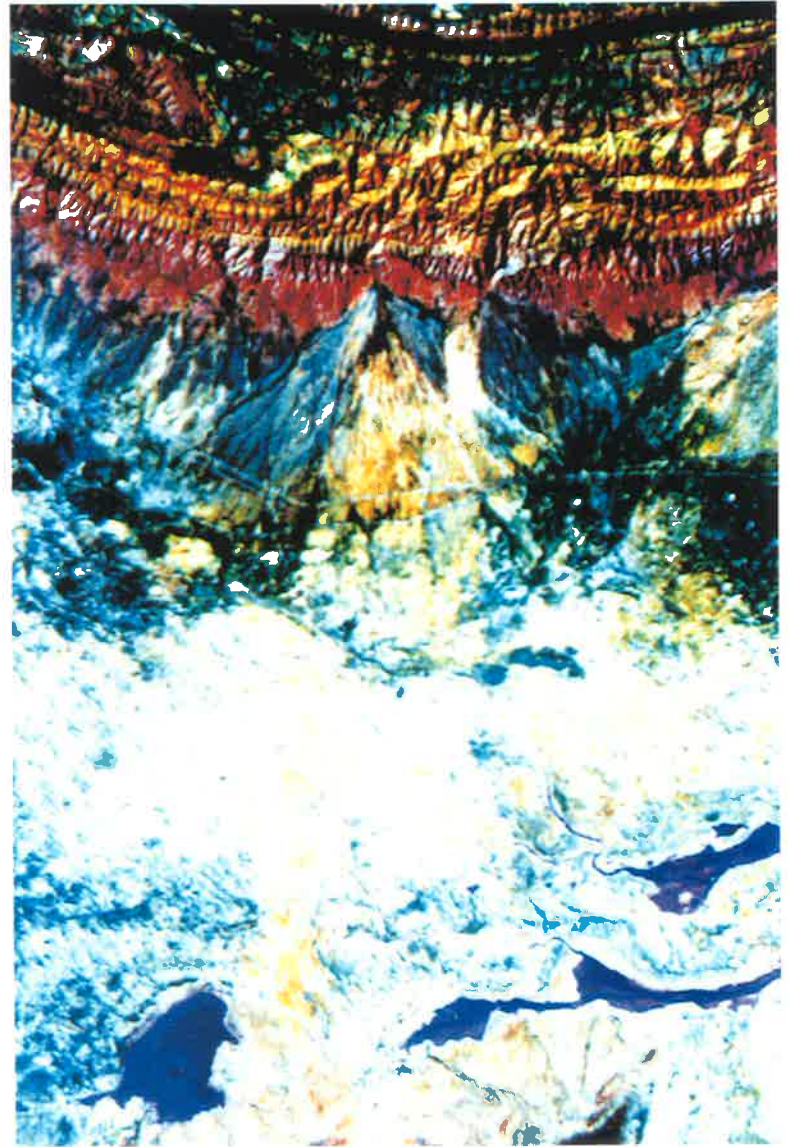
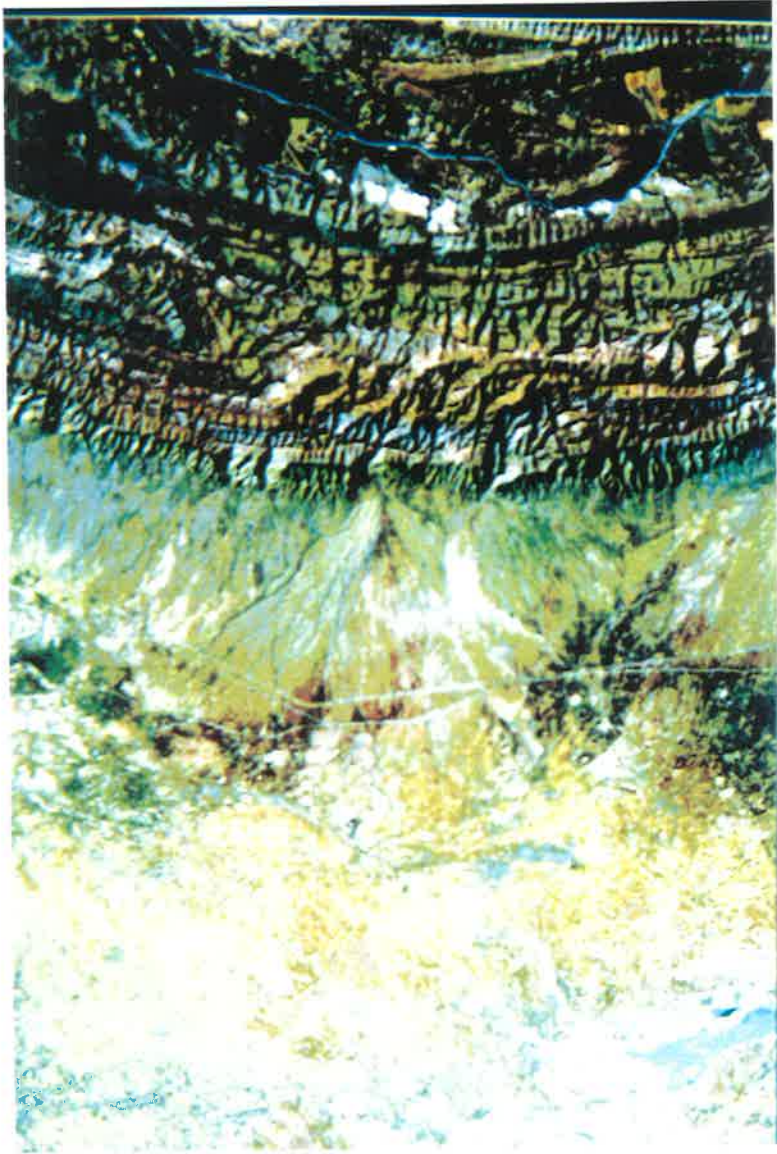


Figure AI.3 (MAP POCKET)

Generalised contours of the Parachilna-Edeowie region (after Pannekoek, 1970).

Source: Source: 1:50 000 Topographic Series, map sheets 6535-1 *Parachilna*, 6535-2 *Edeowie*, 6635-3 *Oraparinna*, 6635-4 *Blinman*, Department of Environment and Natural Resources, South Australia.

Figure AI.4 (MAP POCKET)

Generalised contours of the Wyacca-Emeroo region (after Pannekoek, 1970).

Source: 1:50 000 Topographic Series, map sheets 6433-1 *Wilkatana*, 6433-2 *Port Augusta*, Department of Environment and Natural Resources, South Australia.



Figure AI.5

- (a) Between Bundulla and Walkandi creeks numerous short streams are incised in the main pediment surface at the foot of the escarpment.
  
- (b) Fewer streams dissect the distal slopes of Hayward Pediment.



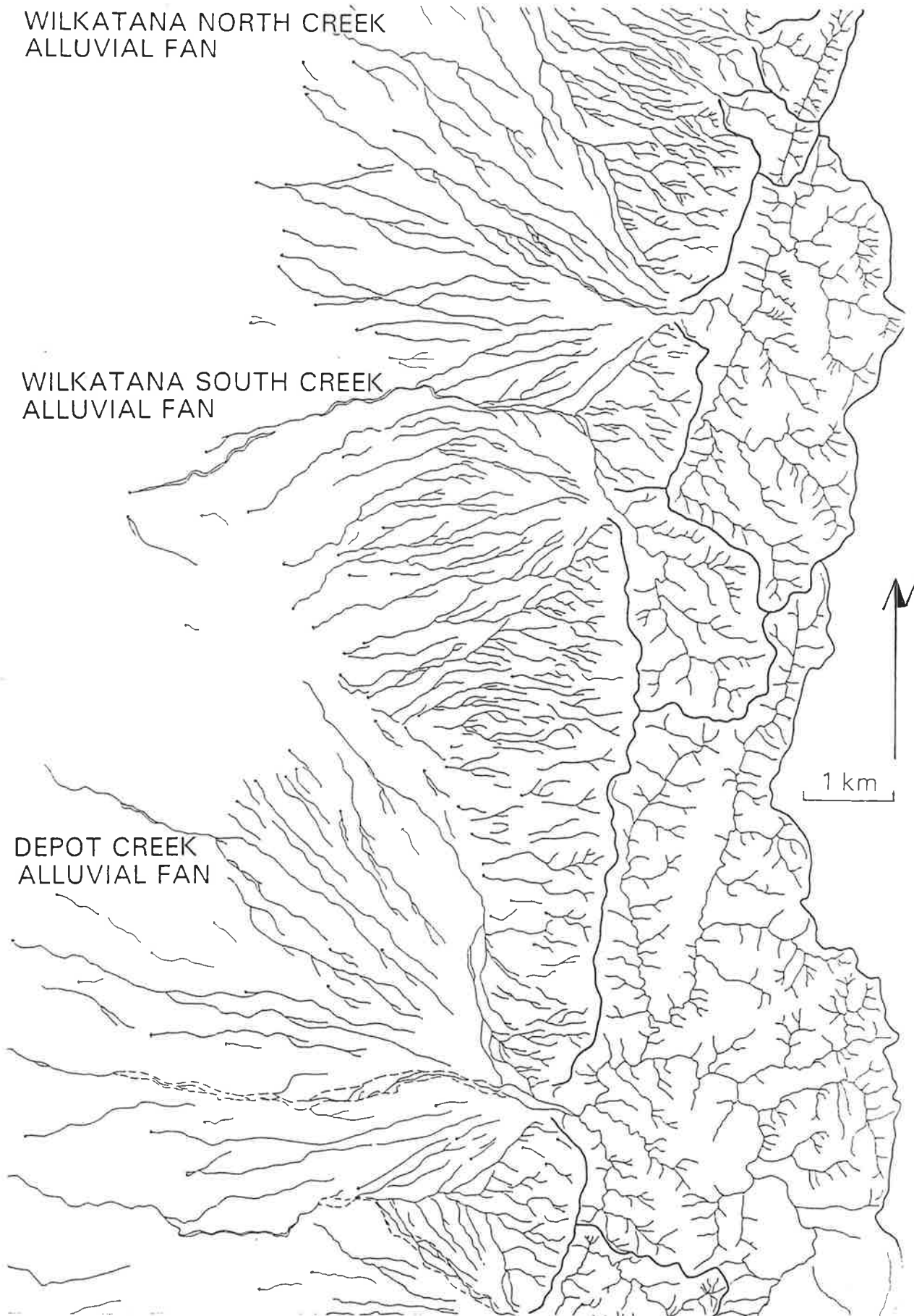
Figure AI.5

- (c) Flows of water and sediment are channelled over the entire surface of alluvial fans.

WILKATANA NORTH CREEK  
ALLUVIAL FAN

WILKATANA SOUTH CREEK  
ALLUVIAL FAN

DEPOT CREEK  
ALLUVIAL FAN



## Figure AI.6

Location map of drainage texture curve sampling strips: Parachilna-Edeowie region.

Source: 1:50 000 Topographic Series, map sheets 6535-1 *Parachilna*, 6535-2 *Edeowie*, 6635-3 *Oraparinna*, 6635-4 *Blinman*, Department of Environment and Natural Resources, South Australia.

Texture curve data were produced for a number of alluvial fans and pediments in the western piedmont of the Flinders Ranges, adapting the method described by Doehring (1970). For the available map scale of 1:50 000, sampling strips were obtained by drawing two parallel lines 2cm apart, across at least 10 contour lines and approximately normal to the trend of the contour lines. Where possible the margins of a landform were not included. Uphill kinks in a contour line, but not broad gentle bends, were counted as contour crenulations (Table AI.1). The count is subjective but recounts made months apart returned surprisingly consistent results. The number of fluvial channels, expressed as contour crenulations are regressed on a number of contour lines. The least squares regression lines thus calculated are called texture curves (Table AI.2).

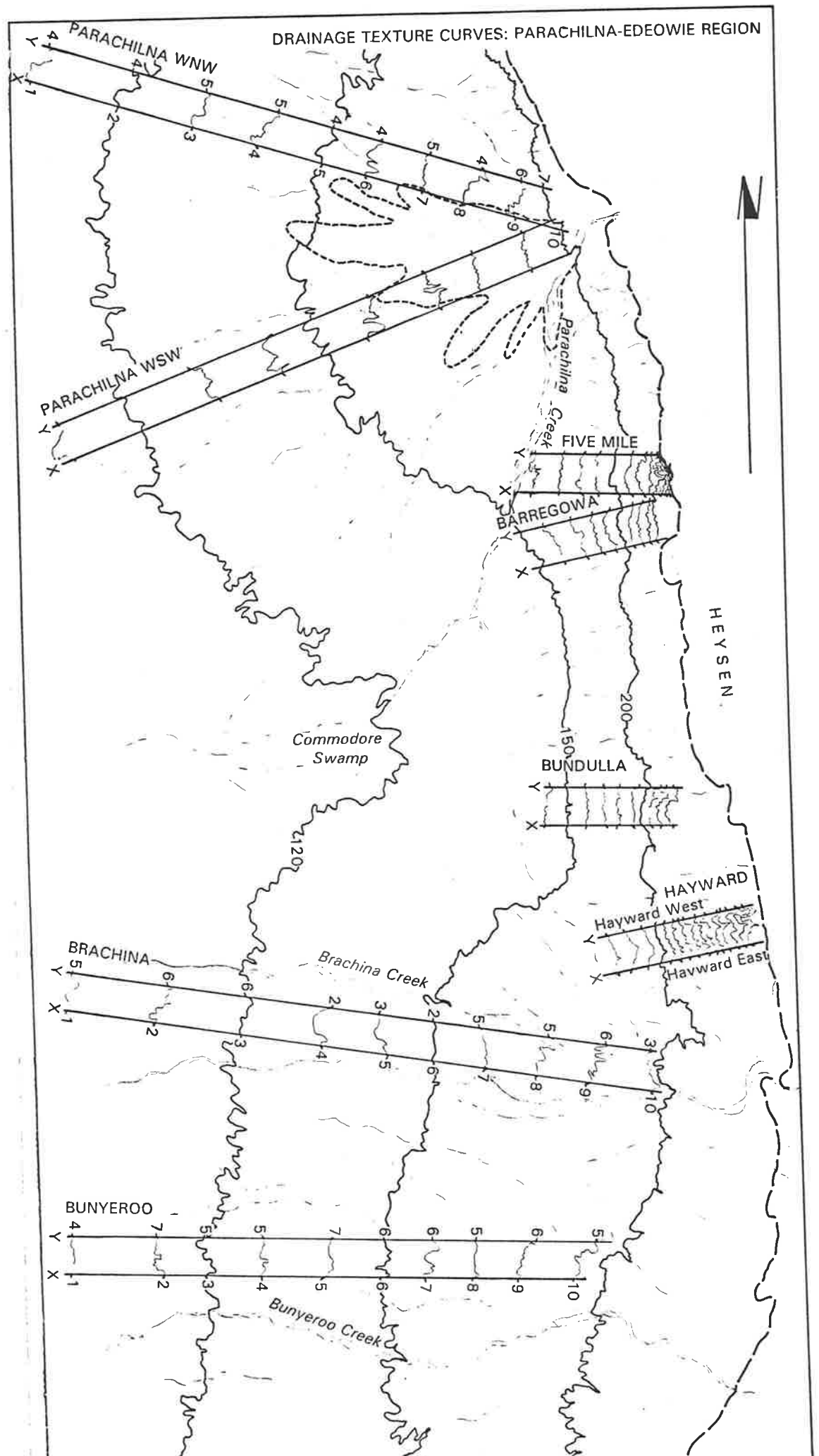


Figure AI.7

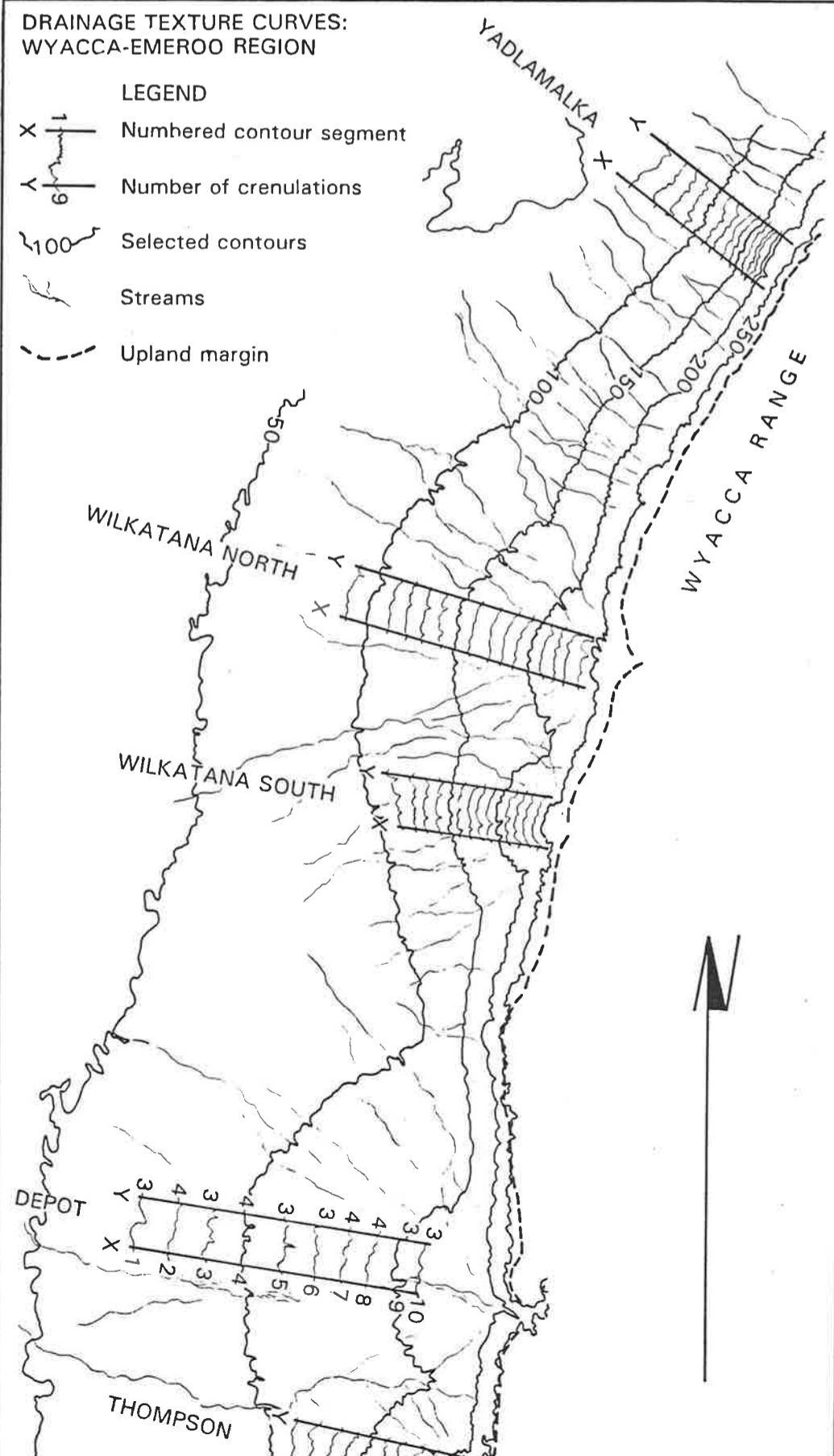
Location map of drainage texture curve sampling strips: Wyacca-Emeroo region.

Source: 1:50 000 Topographic Series, map sheets 6433-1 *Wilkatana*, 6433-2 *Port Augusta*, Department of Environment and Natural Resources, South Australia.

DRAINAGE TEXTURE CURVES:  
WYACCA-EMEROO REGION

LEGEND

- X | 1 | Numbered contour segment
- < | 9 | Number of crenulations
- 100 | Selected contours
- Streams
- - - Upland margin





### Figure AI.8

Texture curves for pediments from the western piedmont of the Flinders Ranges (after Doehring, 1970). Texture curves for Parachilna WSW (2) and Five Mile (3) are comparable with those of pediments and are included in this graph, although they are regarded as alluvial fans. Those for Hayward (6) and Aliena East (13) are included for the landforms are known to be pediments, although their texture curves do not fit (see text for further explanation). See also Tables AI.1 & AI.2 for data set.

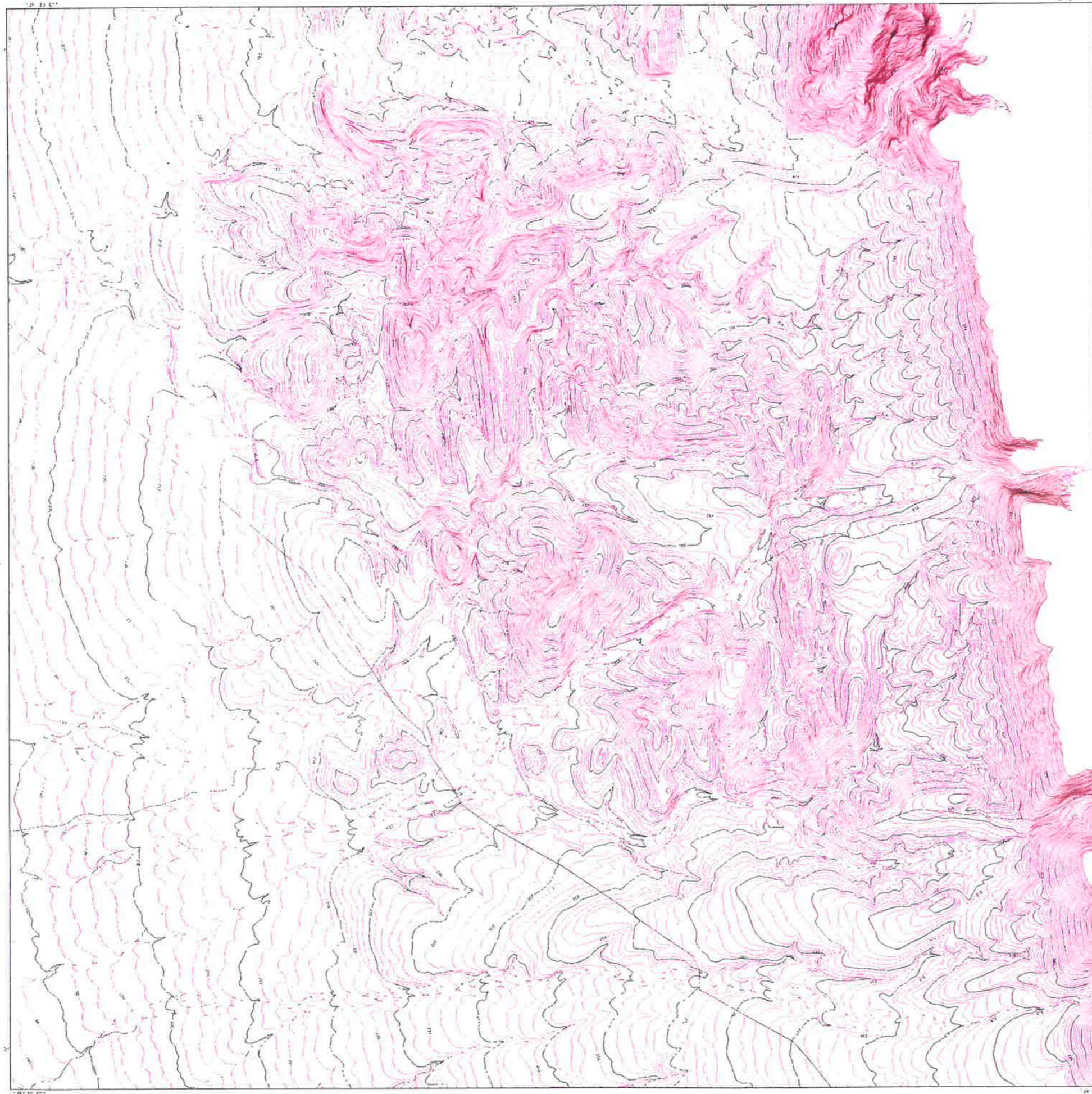
### Figure AI.9

Texture curves calculated for alluvial fans from the western piedmont of the Flinders Ranges (after Doehring, 1970). Texture curves for Hayward (6) and Aliena East (13) are similar to those of alluvial fans and are included in this graph, although they are regarded as pediments. See also Tables AI.1 & AI.2 for data set.



The ..... metre FORM LINES depicted on this map do not conform to standard VERTICAL mapping accuracy performance criteria. Their use should be strictly limited to this specific project.

PEN TABLE .UNC  
PARAMETER FILE .A1.PLT  
DGNAPP FILE .JUELL.DGN



DATE PLOTTED 20/7/93 10:45:10  
SEQUENCES IN FILE 999 SEQUENCES PLOTTED 059  
JOB NAME DGN -> DIG  
MAP NUMBER PROJECT  
ORIGINATOR AERIAL DATA SERVICES  
PHOTOGRAPHY - SURVEY 0 DATE 0/0/0  
ENVIRONMENT & LAND MANAGEMENT, RESOURCE INFORMATION GROUP  
282, Richmond Road, NETLEY, S.A. 5035, Ph 228 4822

SCALE 1:5000  
CONTOUR INTERVAL 2 METRES  
HORIZONTAL DATUM - ANG  
VERTICAL DATUM - AHD

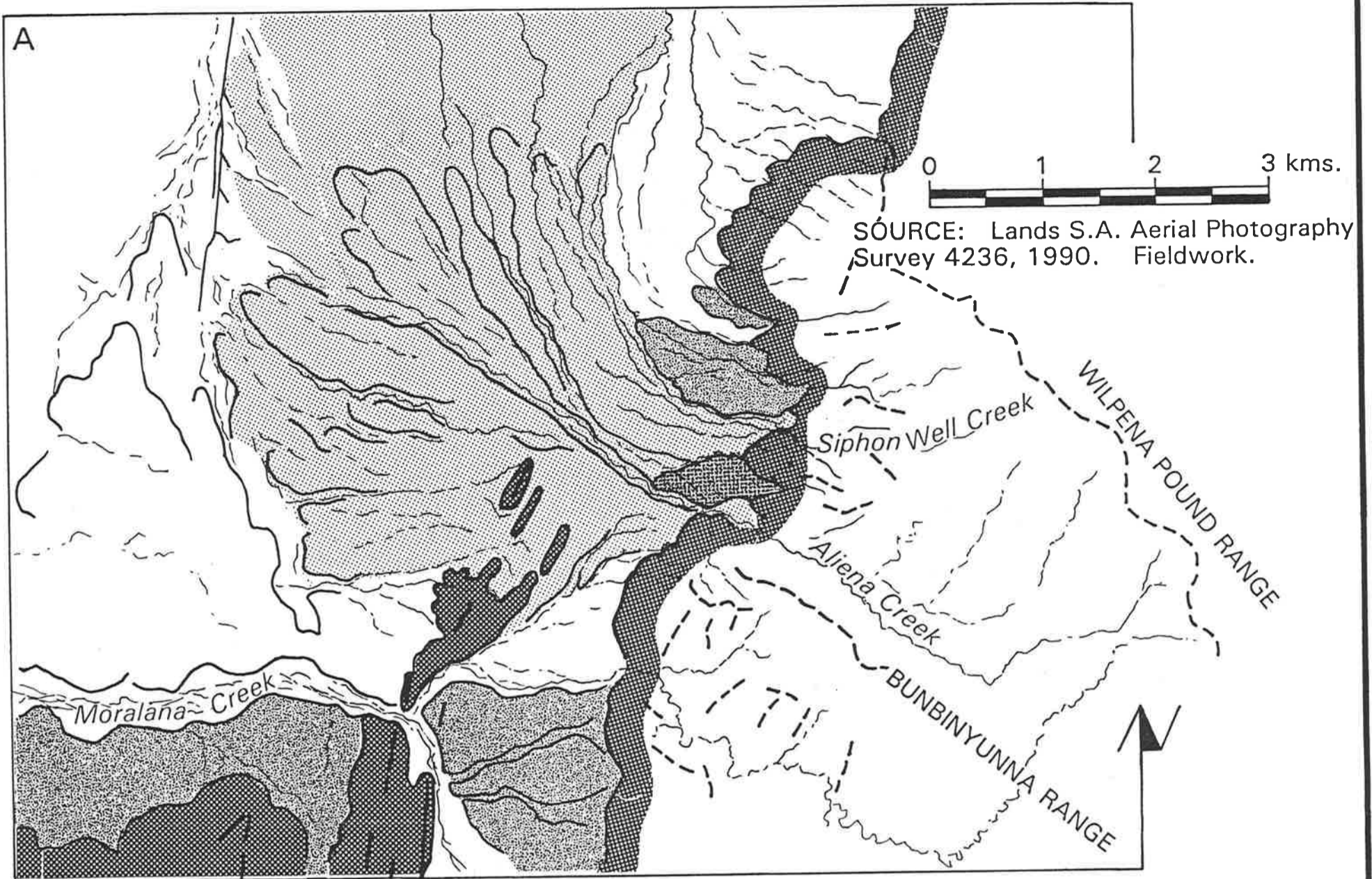
CRAPARINNA

(C) Copyright 1993  
This map is a reproduction of the original map. Permission is granted to reproduce all or part of any form and by any means, subject to the condition that the original map and photographs must be obtained from the Dept of Environment & Land Management.

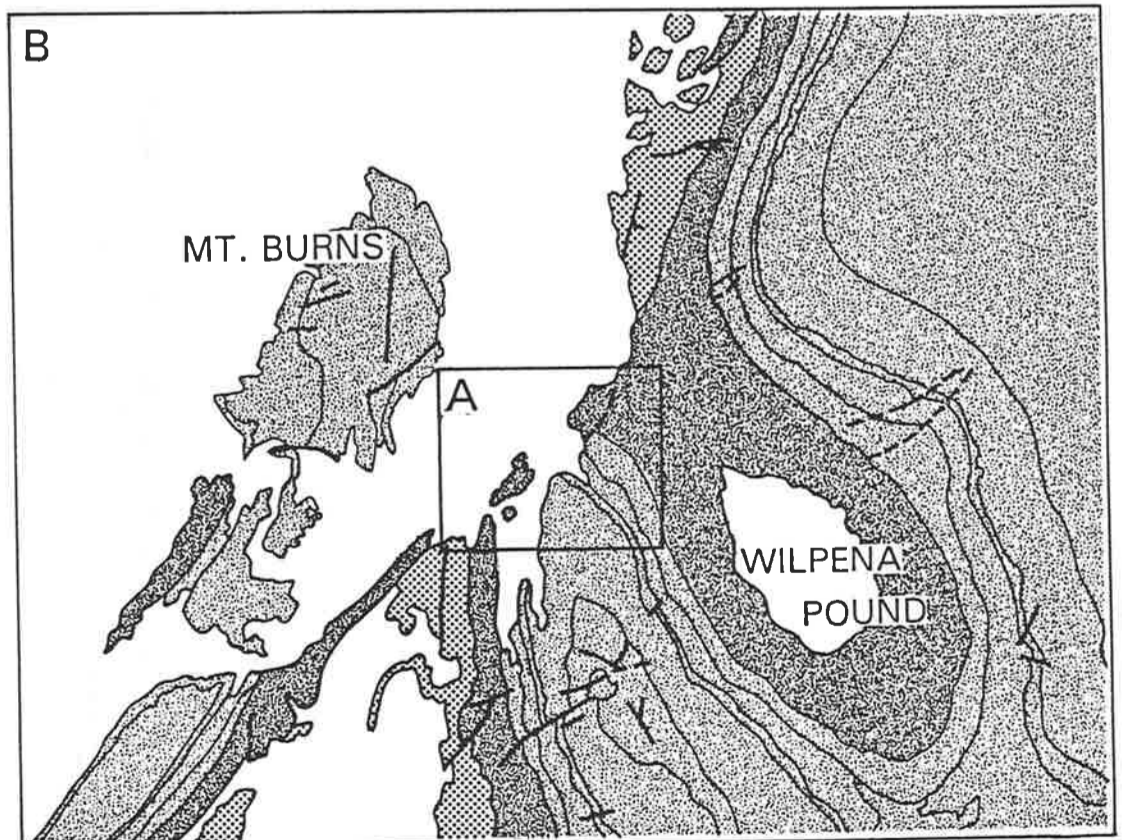
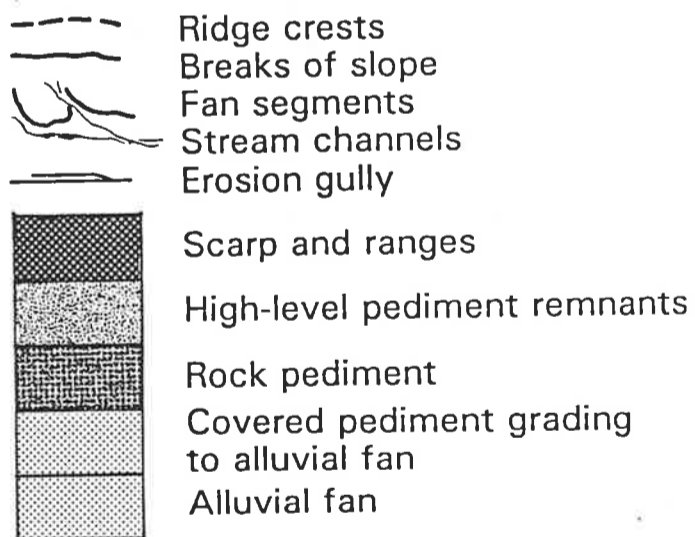
Figure 3.17

Bundulla-Walkandi high pediment remnants in the piedmont of the Heysen Range. Special Project Map, 2 metre form lines (vertical accuracy +/-2 to 3 metres), using data base for 1:50 000 Topographic Series, map sheet 6635-3 *Oraparinna* (Resource Information Group, Department of Environment and Natural Resources, South Australia).

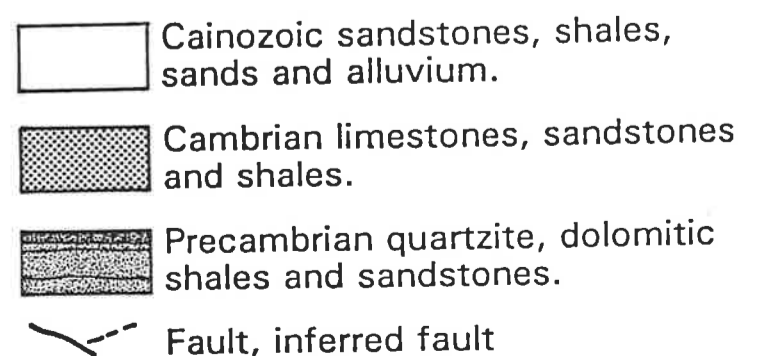
# MORPHOLOGY: ALIENA WASHOUT FLINDERS RANGES, SOUTH AUSTRALIA



## LEGEND



## LEGEND



# SIMPLIFIED GEOLOGY: ALIENA WASHOUT

## SCALE



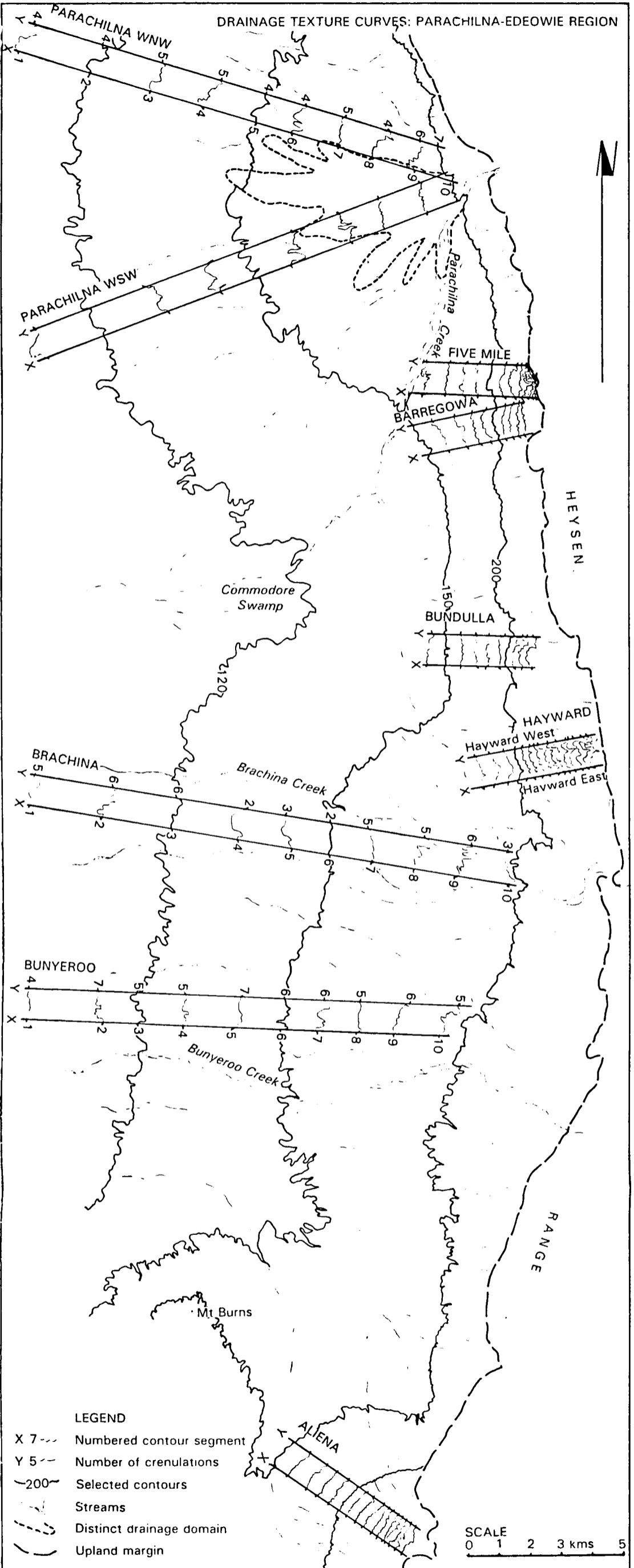
SOURCE: 1:250,000 Geological Series, map sheet Parachilna.

Figure 5.5

Morphology and geology maps of Aliena Washout and environs.

Source: Aerial Photograpy, Survey 4236, 1990, Department of Environment and Natural Resources, South Australia; Dalgarno & Johnson, 1966.

DRAINAGE TEXTURE CURVES: PARACHILNA-EDEOWIE REGION



DRAINAGE TEXTURE CURVES:  
WYACCA-EMEROO REGION

LEGEND

- X ——— Numbered contour segment
- ← ——— Number of crenulations
- 100 ——— Selected contours
- Streams
- - - - Upland margin

