



THE FORMATION OF AROMATIC HYDROCARBONS
AT HIGH TEMPERATURES.

A THESIS
PRESENTED FOR THE DEGREE OF
DOCTOR OF PHILOSOPHY
IN THE
ORGANIC CHEMISTRY DEPARTMENT
OF THE
UNIVERSITY OF ADELAIDE

by
Ronald W.L. Kimber B.Sc.

1959

ACKNOWLEDGMENTS.

I should like to express my appreciation and thanks to Professor G.M. Badger, to whom this work owes its inception, for his constant supervision and advice.

My thanks are also due to Dr. A.J.L. Beckwith and Mr. T.M. Spotswood for helpful discussions, and to other members of the staff for their interest and suggestions.

I also wish to thank Mr. A.G. Moritz for the infrared spectra determinations.

This work has been carried out during the tenure of a grant from the Damon Runyon Memorial Fund for Cancer Research Inc. to whom I am most grateful.

Microanalyses were carried out by the C.S.I.R.O. Microanalytical Laboratory, Melbourne.

STATEMENT

The study of "The Formation of Aromatic Hydrocarbons at High Temperatures", as a whole, is being carried out by several workers in the Organic Chemistry Department of the University of Adelaide; however, this thesis contains no material previously submitted for a degree in any University, either by myself, or by any other person, except where due reference is made.

Ronald W.L. Kimber.

1959.

PUBLICATIONS

Most of the work in this thesis has been published in the following papers:

1. The Formation of Aromatic Hydrocarbons at High Temperatures. Part I. Introduction. J. Chem. Soc., 1958, 2449.
2. The Formation of Aromatic Hydrocarbons at High Temperatures. Part II. An Examination of "Schroeter Tar". J. Chem. Soc., 1958, 2453.
3. The Formation of Aromatic Hydrocarbons at High Temperatures. Part III. The Pyrolysis of 1-4'-Phenylbutylnaphthalene. J. Chem. Soc., 1958, 2455.
4. The Formation of Aromatic Hydrocarbons at High Temperatures. Part VI. The Pyrolysis of Tetralin. J. Chem. Soc., in the press.
5. The Formation of Aromatic Hydrocarbons at High Temperatures. Part VII. The Pyrolysis of Indene. J. Chem. Soc., in the press.

CONTENTS

	Page.
<u>CHAPTER I. INTRODUCTION</u>	
General discussion	1.
Interpretation of results	7.
The formation of 3:4-benzopyrene at high temperatures	8.
Experimental	15.
<u>CHAPTER II. AN EXAMINATION OF "SCHROETER TAR".</u>	
Discussion	29.
Experimental	39.
<u>CHAPTER III. THE SYNTHESIS AND PYROLYSIS OF 1-4'-PHENYLBUTYLNAPHTHALENE AND RELATED COMPOUNDS.</u>	
The pyrolysis of 1-4'-phenylbutylnaphthalene	55.
The pyrolysis of a partially dehydrogenated 1-4'-phenylbutyldecalin and 1-4'- <u>cyclo-</u> hexylbutyldecalin	64.
The attempted synthesis of 5-4'-phenylbutyl- tetralin	66.
Experimental	71.

CHAPTER IV. THE PYROLYSIS OF TETRALIN
AND INDENE.

Tetralin	100.
Indene	111.
Experimental	124.
REFERENCES	152.
SUMMARY	159.

CHAPTER I



INTRODUCTION

The aim of the work described in this thesis was to investigate the mode of formation of aromatic hydrocarbons at high temperatures by pyrolysis of simpler hydrocarbons. It was hoped that a greater understanding of the complex reactions which takes place during tar formation would be gained from this work.

In particular, the mechanism of the formation of the carcinogenic hydrocarbon 3:4-benzopyrene, at high temperatures, has been examined.

General Discussion

It has been known for some years, from studies of the composition of coal tar formed in gas works' retorts and coke ovens, that various pyrolytic processes occur during the formation of the tar, which are dependant to a large extent on the temperature at which the tar is formed.

For example, low temperature tars (i.e. 425-550°) and "Primary" tar (tar which is first formed in the retort at low temperatures) consist mainly of paraffin

hydrocarbons, cycloparaffins, olefins, and phenols. At higher temperatures (600-800^o) these compounds are dehydrogenated, rearranged, and condensed to give a "Secondary" tar containing a greater amount of aromatic polycyclic hydrocarbons. Evidence of this has been given by various workers. Mantel and Hansen¹ have shown that diphenylmethane, diphenyl and ethylene, and 1:8-dimethylnaphthalene, all of which are present in "Primary" retort tar, when pyrolysed under similar conditions in the laboratory give fluorene, phenanthrene and acenaphthene (reactions 1, 2, and 3), all of which have been isolated from "Secondary" (i.e. high temperature) retort tars.

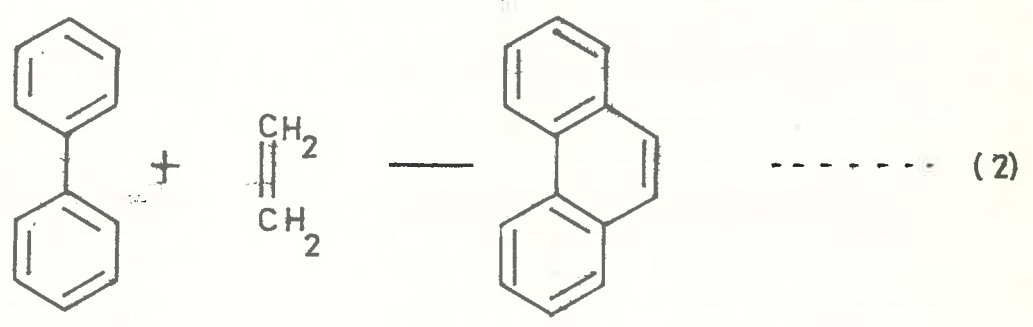
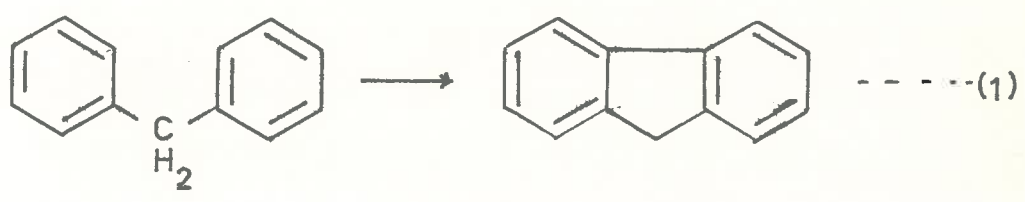

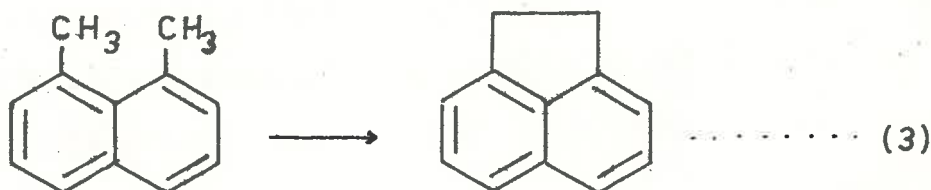

Several workers have suggested that the formation of polycyclic compounds involves the initial breakdown of complex molecules to more simple ones. Groll² assumes that the breakdown continues right down to acetylene before resynthesis commences. He suggests that the primary intermediate from which all the higher hydrocarbons are eventually formed is the diradical of acetylene. On the other hand, Weizmann et al.³ assume that butadiene (or derivatives of it) is the fundamental unit. Their suggestion is that the resynthesis follows almost entirely a Diels-Alder type addition and is based on the results of various workers^{4,5,6} (e.g. Hague and Wheeler have shown evidence of the formation of butadiene and butylene from the pyrolysis of ethylene at low temperatures, while at higher temperatures reasonable yields of benzene and naphthalene were obtained. - reaction 4).

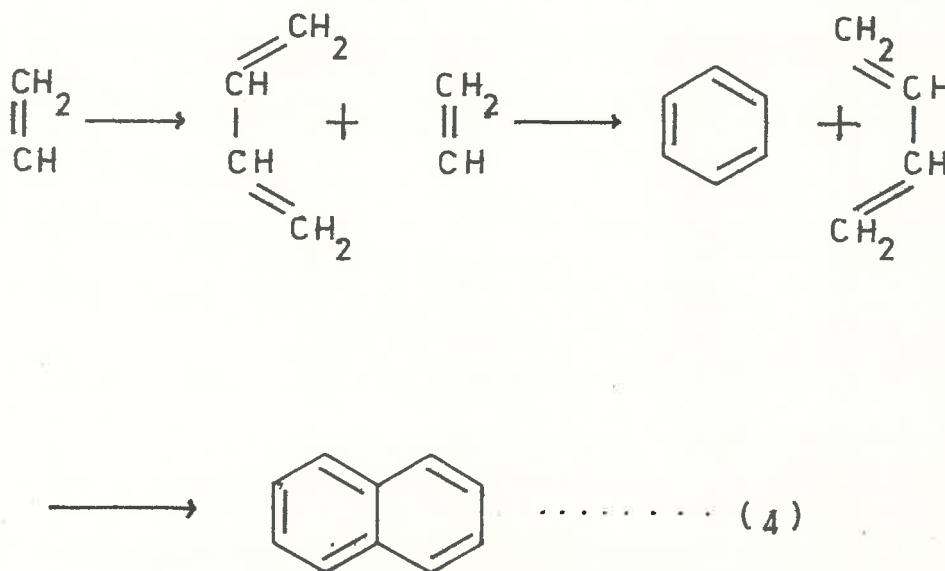

Weizmann extends this to explain the presence of phenanthrene, anthracene, 1:2-benzanthracene, and triphenylene by Diels-Alder addition of butadiene to naphthalene and phenanthrene, in his pyrolysis of a hydrocarbon oil. At first glance this mechanism seems very reasonable. Closer examination, however, shows it to be relatively unlikely. As Diels-Alder addition to the very reactive 9:10 bond of phenanthrene would be expected to occur very readily, the yield of triphenylene should be quite large. Not only is the yield in this case small, but also in the pyrolysis of butylbenzene,

which gives a large yield of phenanthrene, very little triphenylene⁷ is obtained. Furthermore, Weizmann also suggests that pyrene is formed from tetramerisation of butadiene, or dimerisation of styrene (reaction 5).

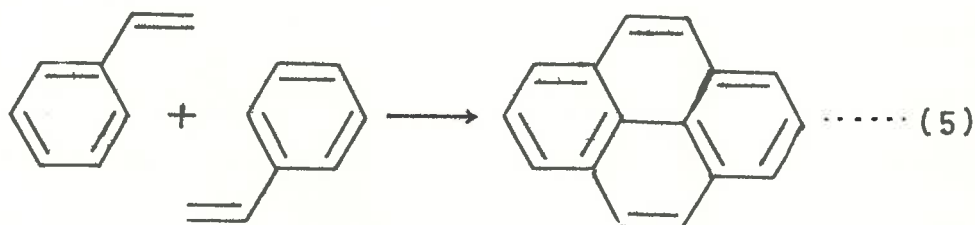

This has been shown to be most unlikely by Badger and Buttery⁸, who have pyrolysed styrene and obtained only a very small amount of pyrene.

Only in pyrolyses where butadiene can easily be formed, (e.g. the pyrolysis of 1-phenylbuta-1:3-diene⁹) is much triphenylene found. Even here the yield is not high, and the suggestion is that triphenylene is formed by free radical attack of a butadienyl radical (formed by fission of the carbon-carbon bond between the ring and the butadienyl side-chain) on the 9-position of phenanthrene, followed by cyclisation, rather than by a Diels-Alder mechanism.

Steiner¹⁰ says the condensation of naphthalene and

butadiene gives a small yield of phenanthrene. One would then expect to obtain large yields of naphthalene compared with phenanthrene. However, the pyrolysis of propylbenzene⁷ and ethylbenzene⁷ give greater yields of phenanthrene.

It would seem, therefore, that even when butadiene can be readily formed from carbon-carbon fission or by dehydrogenation (e.g. from butane) Weizmann's proposed mechanism seems most unlikely. Where the formation of butadiene does not involve the breaking of a benzene ring (as it is very stable to pyrolysis¹¹) a Diels-Alder type addition could play some part. In this regard the pyrolysis of butadiene by Murphy and Duggan¹² gives only a small yield of styrene.

Quite apart from these considerations, the results as judged from the pyrolysis of complex hydrocarbon oils must surely be open to question. Much interaction will undoubtedly occur not only among the products of cracking, but also of the original components.

The addition of ethylene (or acetylene diradicals) to hydrocarbons to form higher aromatics also seems improbable (e.g. chrysene, or 1:2-benzanthracene and ethylene to give 3:4-benzopyrene) from evidence gained from the pyrolysis of tetralin and of indene (Chapter IV).

Interpretation of Results

Care must be taken when evaluating results obtained from pyrolyses in order to arrive at the most likely mechanisms. The following points should be especially remembered:

(1) When considering the yield of a certain product as a guide to a mechanism, it is necessary to take into account;

(a) the ease of thermal breakdown of the substance pyrolysed compared with that of the particular product in question;

and, (b) the stability of a particular compound of the pyrolysate to further breakdown, or its tendency to react with other molecules; e.g. the absence of phenylbutadiene⁹, butylbenzene, and tetralin from most high temperature pyrolyses does not mean that these molecules take no part as intermediates in the synthesis of higher hydrocarbons, due to their ease of dehydrogenation, cyclisation, etc.

(11) Mechanisms which are the most likely at room temperature, and in low temperature reactions, need not

necessarily apply at high temperatures. At these temperatures, the molecules are in a highly excited state and the usually greater reactivities of some positions in a molecule are likely to be less apparent. It should be noted too, that steric factors will probably hold greater sway than electrical effects at these elevated temperatures.

The Formation of 3:4-Benzopyrene at High Temperatures

The carcinogenic hydrocarbon 3:4-benzopyrene was isolated from coal tar in 1933 by Cook et al.¹³ Immediately, this was considered to be the cause of certain "industrial" cancers. In recent years, however, 3:4-benzopyrene and other polycyclic hydrocarbons have been identified in domestic soot¹⁴, in the soot from a smoked meat factory¹⁵, in atmospheric dust¹⁶, in processed rubber¹⁷, in carbon blacks¹⁸, in exhaust gases of petrol and diesel engines¹⁹, in coal gas²⁰, in human hair wax²¹, in snuff²², in tobacco²³, and in cigarette and tobacco smoke²⁴. This widespread occurrence in everyday environment has obvious implications in connection with the incidence of cancer among the general population, and it seems important to determine the origin and mode

of formation of such carcinogenic hydrocarbons.

The carcinogenic hydrocarbons in the human environment appear to be formed mainly at high temperatures. Low temperature tars have been found to be only slightly carcinogenic, whereas high temperature tars, produced from the same coal, are far more active²⁵. Similarly certain petroleums²⁵, and oil²⁶ have only become carcinogenic after pyrolysis. The pyrolysis of cholesterol²⁷, skin²⁵, yeast²⁵, isoprene^{25,28}, acetylene²⁵, dicetyl²⁹ and of aliphatic hydrocarbons³⁰ from tobacco all give tars which are carcinogenic, or from which have been isolated numerous polycyclic aromatic hydrocarbons.

The formation of aromatic hydrocarbons from aliphatic or simpler aromatic compounds, at high temperatures has not been extensively studied. The evidence that is available, however, suggests that the most important reactions may involve:

- (i) Cracking, with the formation of free radicals which then undergo termination reactions with themselves or propagation reactions with neutral molecules;
- (ii) Dehydrogenation; and
- (iii) Cyclodehydrogenation.

A series of such reactions is probably involved in the formation of molecules such as 3:4-benzopyrene, and a feasible route (reactions I - VII) has been proposed as a working hypothesis.

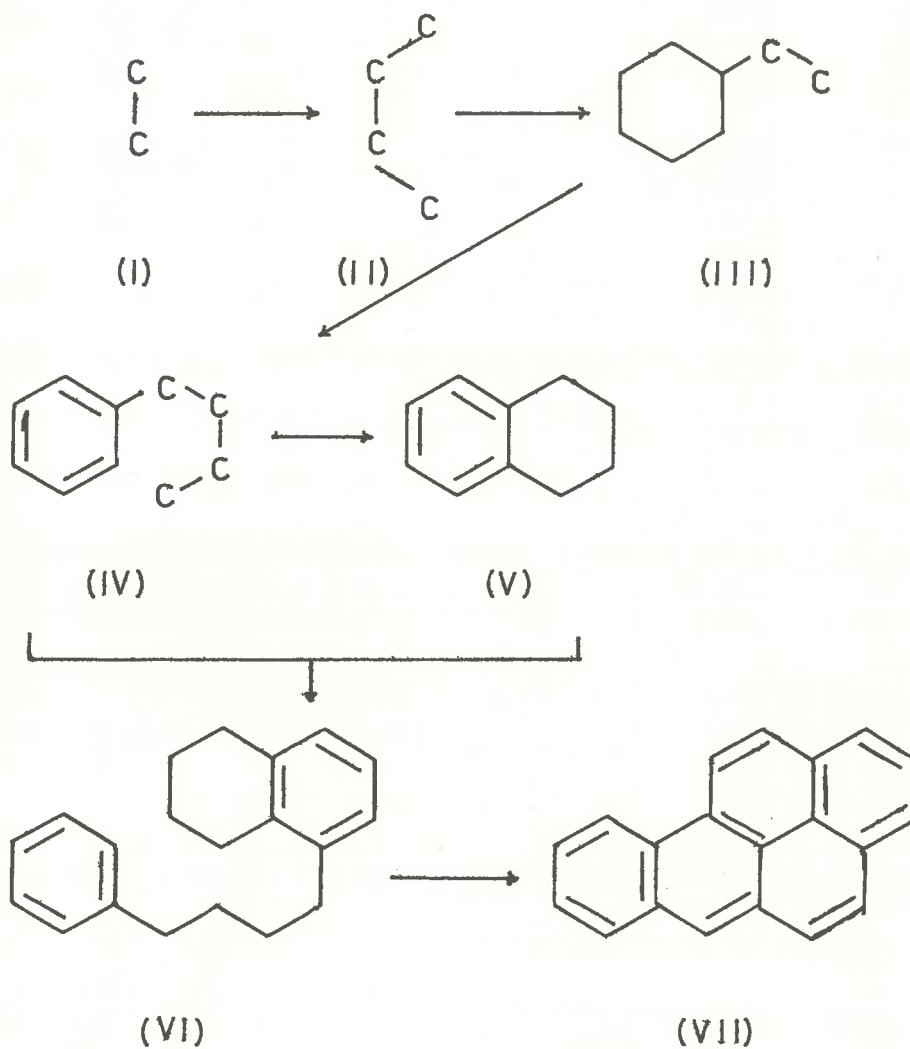

This mechanism presupposes that the benzopyrene will be formed by pyrolysis of any of the intermediate compounds. Pyrolysis of representatives of these intermediates has in every instance produced a tar in which 3:4-benzopyrene could be detected; viz. acetylene³¹, styrene⁸, ethylbenzene⁷, 1-phenylbuta-1:3-diene⁹, butylbenzene⁷, tetralin (Chapter IV), and 1-4'-phenylbutylnaphthalene (Chapter III).

The degree of hydrogenation of these intermediates would be expected to alter the yield of a given product, and also in some instances, the nature of the products formed by pyrolysis of a compound and its analogous hydrogenated compound. This is borne out by experiment (e.g. phenylbutadiene⁹ gives a large yield of naphthalene, while butylbenzene⁷ gives less naphthalene, but a much wider range of alkylbenzenes.) The reactions (6) and (7) also occur.

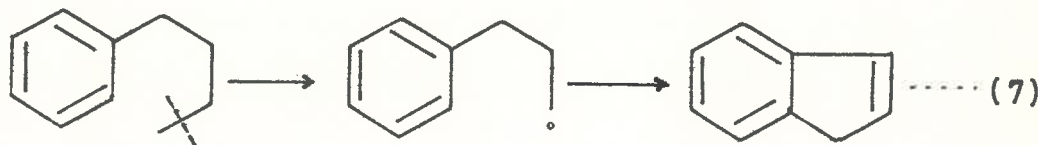
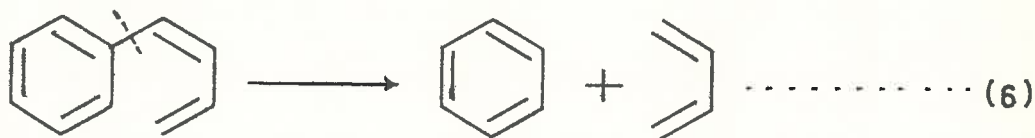

Generally it may be said that where polycyclic compounds are formed merely by cyclisation of the intermediates as such, then the degree of hydrogenation may not be important; but if cracking occurs prior to cyclisation, intermediates with varying degrees of hydrogenation will give rise to different products from cracking, and hence different cyclisation products.

The available evidence, small though it is, does support the view that benzopyrene is formed from simpler units by a stepwise synthesis. The pyrolysis of acetylene (I) is known to give a number of aromatic hydrocarbons³² and has been shown recently to contain 3:4-benzopyrene³¹. Acetylene and small amounts of vinylacetylene have been detected in tobacco smoke³³. The pyrolysis of ethylene also gives butadiene (see General Discussion). Butadiene is said to undergo reaction with itself to give vinylcyclohexene³⁴, and the pyrolysis of butadiene gives some styrene, ethylbenzene, and naphthalene, together with a small amount of tetralin¹². A clue to the nature of the final steps of the synthesis is provided by the reaction of aluminium chloride on tetralin³⁵. The complex tar so formed, becomes carcinogenic when heated³⁶, and has now been shown

to contain a relatively large amount of 3:4-benzopyrene (see Chapter II). 6-4'-Phenylbutyltetralin is known to be a major constituent of the tar³⁵, and it has been suggested that some 5-4'-phenylbutyltetralin may also be present which could readily give 3:4-benzopyrene by cyclodehydrogenation³⁷.

While this mechanism was considered useful as a working hypothesis, it was not suggested that this would be the only mechanism operating. Other routes could involve the reaction of a C₂ unit (e.g. ethylene) and chrysene or 1:2-benzanthracene; pyrene and a C₄ unit; various arrangements of two C₆ - C₄ units with initial attack at different positions; etc. Evidence does suggest, however, that ethylene and chrysene, and ethylene and 1:2-benzanthracene are not important reactions (Chapter IV); nor can a reaction between a C₄ unit and pyrene be of general importance as such a reaction would give rise to 1:2-benzopyrene. This is rarely found in pyrolysis reactions, and then only in small yield. 3:4-Benzopyrene could also be formed by breakdown of larger molecules (e.g. dicetyl²⁹) or from two C₁₀ hydrocarbons, such as n-decane³⁸, by cyclodehydrogenation.

Recent work suggests that styrene may not play a

very important part in the proposed stepwise formation of 3:4-benzopyrene, as it has been shown to be relatively stable to pyrolysis; i.e. at 550° the reported³⁹ recovery of styrene is 99%; at 625°, 95.5%⁴⁰; while at 710° approximately 20% is recovered⁸.

It must be emphasised that generally it cannot be stated that the pyrolysis of a compound invariably proceeds through initial cracking to a fundamental unit, followed by resynthesis. In fact, this would appear to be the exception rather than the rule (except perhaps for aliphatic compounds). The degree and the nature of the cracking will vary from one compound to another. It would appear generally, therefore, that cracking, dehydrogenations, cyclodehydrogenations, etc. all proceed together. The extent to which cracking occurs before resynthesis will depend largely on the stability of the radicals so formed, and on the available reactive species with which they can react. L.S

The experimental section of this chapter describes some of the general methods and techniques used in this work.

EXPERIMENTAL.

The Furnace (Fig. 1.1).- This consisted of a silica tube (3 ft. x 1 in. i.d.) wound along its length with 25 s.w.g. nichrome wire having a total resistance of 90 ohms. A calibrated chromel-alumel thermocouple was inserted through a hole bored near the centre of the tube. The tube was mounted along the centre of a pressed asbestos-board box (3 x 1 x 1 ft.) filled with "vermiculite". The material to be pyrolysed was led through a second silica tube (3 ft. 6 in. x $\frac{1}{4}$ in. i.d.) which just fitted into the heated tube. The furnace was inclined at an angle of 10° to the horizontal to facilitate collection of the products. The material to be pyrolysed was led into the furnace using the device shown in Fig. 1.1. The arrangement of the tar collection apparatus is also shown in this diagram.

Chromatography.- (i) Gas-liquid partition chromatography. The low boiling fractions of the earlier pyrolyses were examined on the machine built in this laboratory⁴¹. However, a Griffin and George Vapour Phase Chromatograph (Mk. II), adapted to collect fractions⁴², was used in the later work.

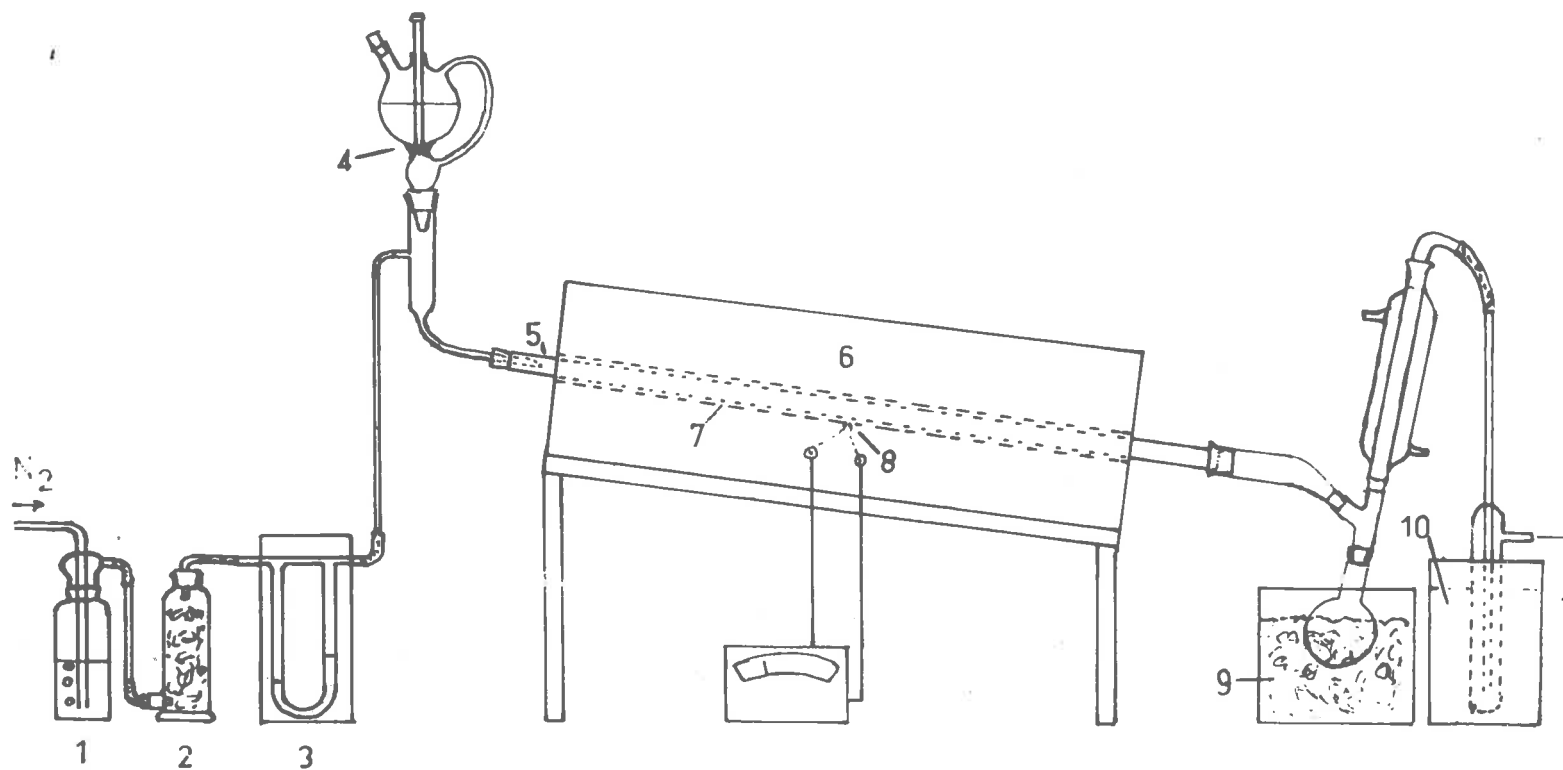

PYROLYSIS APPARATUS.

- 1. H_2SO_4
- 2. $CaCl_2$
- 3. Flow-metre.

- 4. Needle valve
- 5. Silica tube
- 6. Furnace
- 7. Heating tube
- 8. Thermocouple
- 9. Ice bath

- 10. Dry-ice trap

Fig. 1.1.

(ii) On alumina. B.D.H. alumina activated at 200° was generally used, however, in the last pyrolysis, viz. indene, Spence alumina, which is more active, was used. Hexane and/or benzene were generally used as solvents and/or elutants. The benzene used was thiophen-free while the hexane had been fractionally distilled.

(iii) Paper chromatography. The partially acetylated paper required was made by the method of Spotswood^{43,44}. (This technique was only fully developed very recently and was available only for the examination of the products from the tetralin and indene pyrolyses).

(iv) Chromatography on cellulose acetate columns. Whatman's Standard cellulose powder was acetylated by stirring with benzene, acetic anhydride, and sulphuric acid, also by the method of Spotswood⁴⁴. (This technique was developed in time only for use in the indene pyrolysis).

Identification of Products.- Generally the following sequence of operations has been found best when attempting to analyse a complex tar. (It is shown schematically in Fig. 1.2).

The substance was pyrolysed and the products

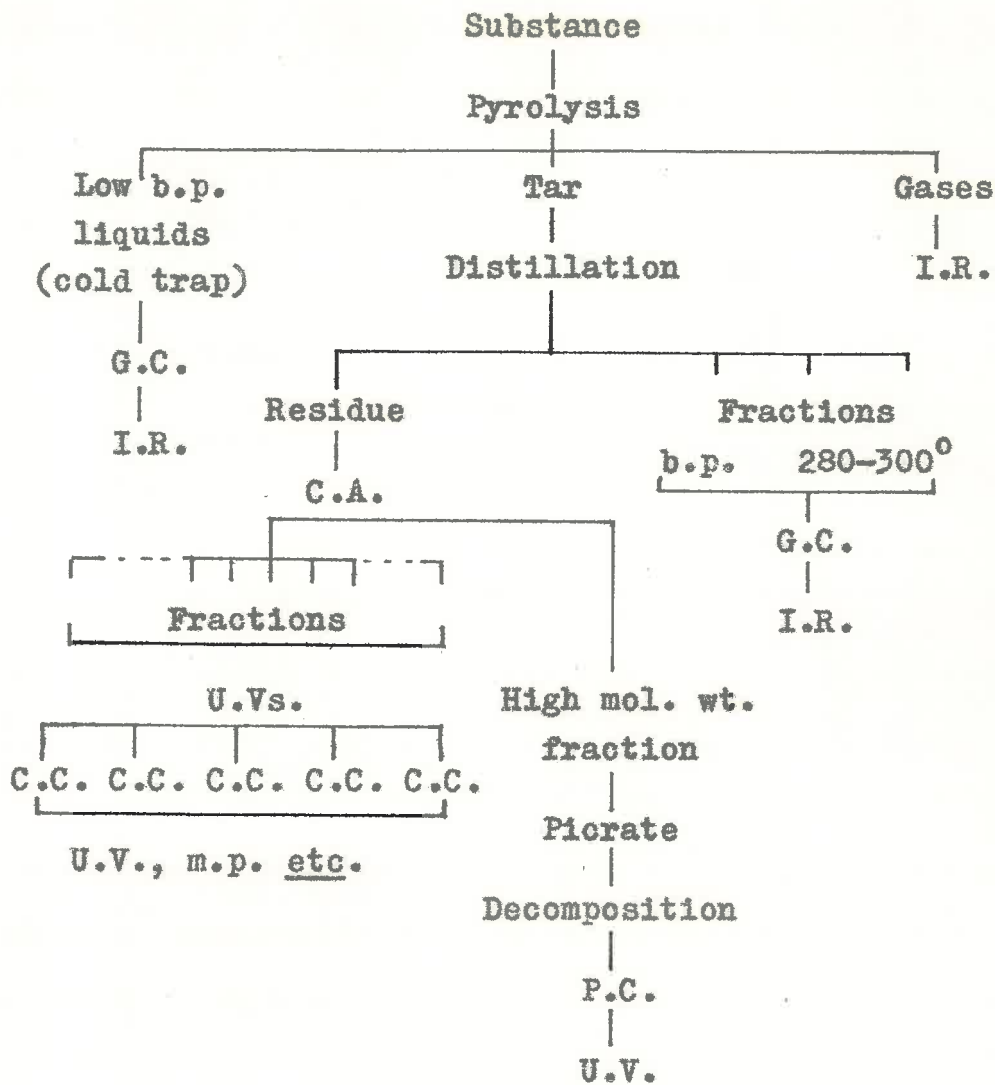

I.R. = Infrared spectra; U.V. = Ultraviolet spectra;
G.C. = Gas-liquid chromatography; C.A. = Column
alumina chromatography; C.C. = Cellulose acetate
chromatography; P.C. = Acetylated paper chromatography.

Fig. 1.2.

collected in the manner shown in Fig. 1.1. Samples of the exit gases were examined by infrared analysis. Some of the low boiling products which were not collected with the main bulk of the tar, were condensed in a dry-ice/ethanol trap. Gas-liquid chromatography of this material enabled provisional identification from retention times. This was confirmed by collection of the fractions and infrared spectroscopy. The main bulk of the tar was distilled and divided into two or three fractions up to b.p. 280-300^o, the components of which were identified by gas-liquid chromatography and infrared spectroscopy. The residue was chromatographed on alumina and eluted with mixtures of hexane and benzene (from pure hexane to pure benzene). Ultraviolet spectra of the fractions enabled many to be combined to give between 5 and 10 main fractions (e.g. phenanthrene fraction, 1:2-benzanthracene fraction, chrysene fraction, 3:4-benzopyrene fraction, etc.). These were in turn chromatographed (as a whole, or in part) on columns of cellulose acetate, and the products identified by their ultraviolet spectrum or melting point. The yields were calculated from the weights of these fractions or from their ultraviolet spectra. The very high molecular weight compounds,

which remained on the alumina column, were stripped off with ether, picrates made, and after decomposing with ammonium hydroxide, paper chromatographed.

Occasionally the chromatography on cellulose acetate needed to be followed by paper chromatography to effect a better separation. When a large amount of any one compound was present it was usually most effective to recrystallise this separately and to add the mother liquors to the rest of the fraction for examination as described above.

Ultraviolet Spectra.- These were usually determined in 95% ethanol, using, for the work in Chapters II and III a Hilger Uvispek Spectrophotometer, and for the work in Chapter IV an Optica CF₄ Spectrophotometer recording instrument, and compared with published curves.

Infrared Spectra.- These were determined with a Grubb-Parsons double-beam instrument. Liquid samples were examined as such, and solids as solutions in carbon tetrachloride. The spectra were compared with published curves, or curves obtained from authentic specimens.

Fluorescence Spectra.- The following apparatus (Fig. 1.3, 1.4, and 1.5), although inexpensive, was found

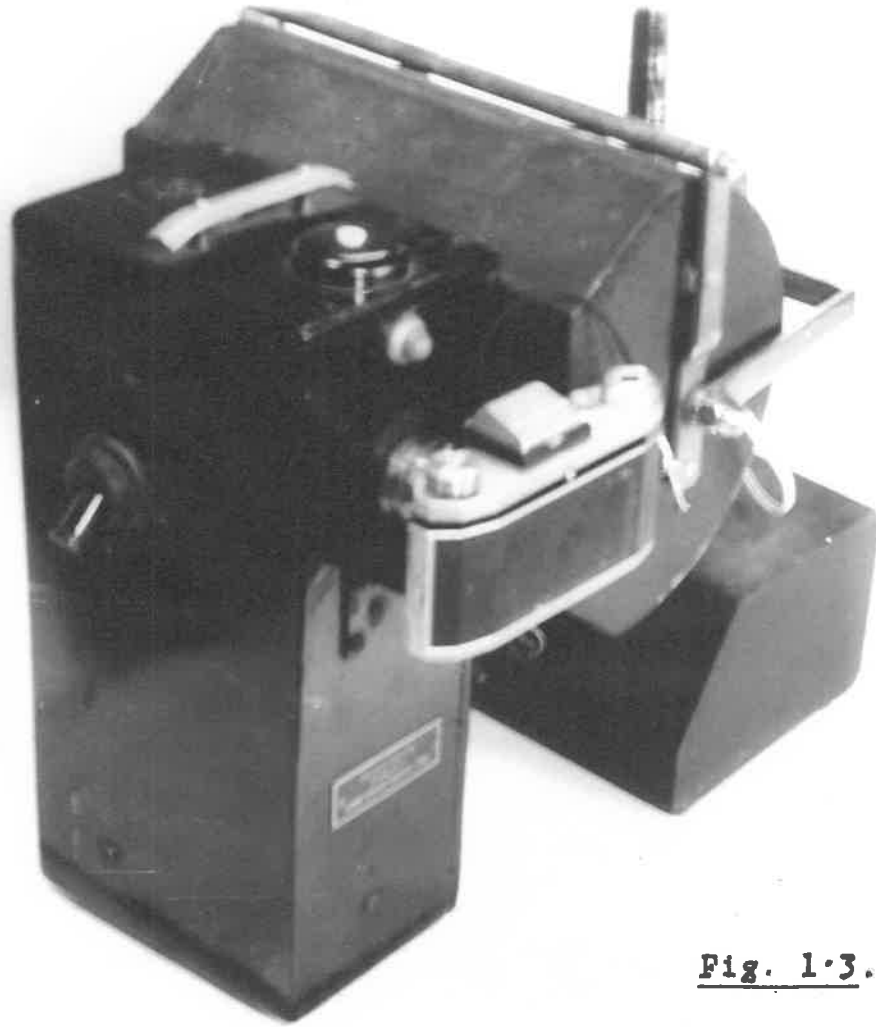
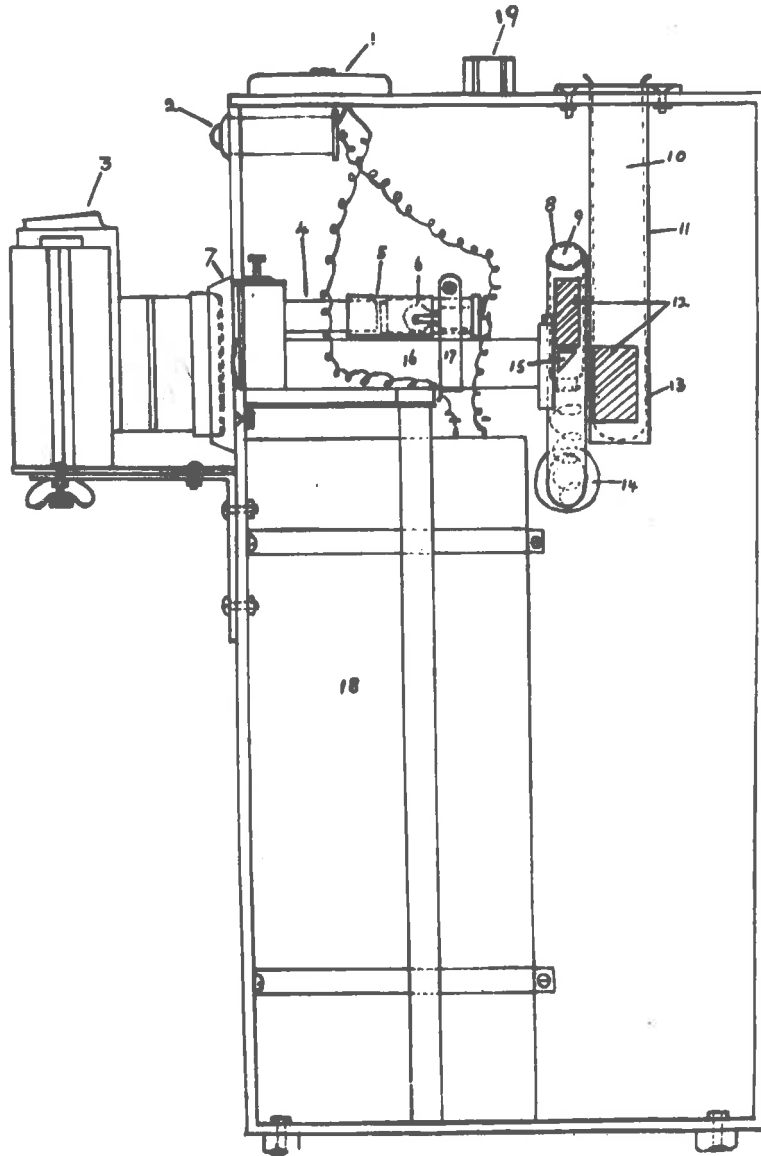

Fig. 1.3.



FLUORESCENT SPECTROPHOTOMETER.

INSIDE SIDE VIEW

- | | | |
|--------------------|-------------------------|------------------|
| 1. Press Button | 8. Standard Tube Holder | 15. Prism |
| 2. Indicator Light | 9. Standard Tube | 16. Spectrometer |
| 3. Camera | 10. Unknown Tube | 17. Clamp |
| 4. Scale Tube | 11. Unknown Tube Holder | 18. Battery |
| 5. Rubber Sleeve | 12. Windows | 19. Handle |
| 6. Scale Lamp | 13. Aluminium Foil | |
| 7. Rubber Seal | 14. Rubber Grommet | |

Fig. 14.

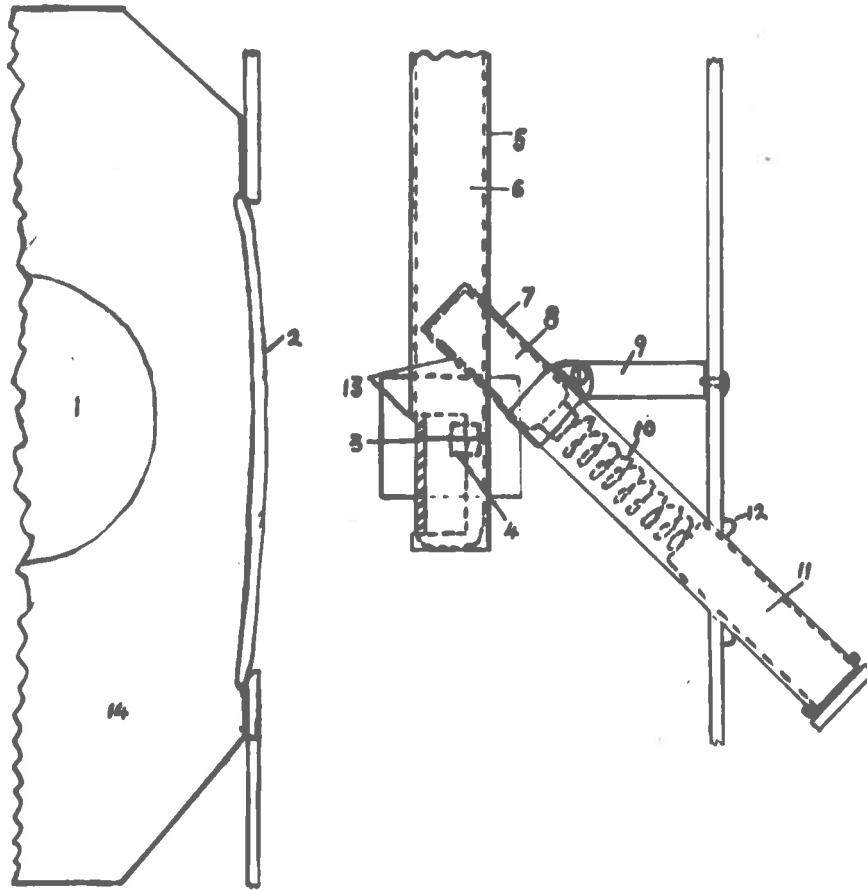

END VIEW SECTION

- | | |
|-------------------------|----------------------------|
| 1. Ultraviolet Lamp | 8. Standard Tube |
| 2. Wood's Glass Filter | 9. Clamp |
| 3. Slit | 10. Spring |
| 4. Prism | 11. Standard Removing Plug |
| 5. Unknown Tube Holder | 12. Rubber Grommet |
| 6. Unknown Tube | 13. Windows |
| 7. Standard Tube Holder | 14. U.V. Lamp Holder |

FIG. 1-5.

to be very convenient and efficient.

A direct vision, prism, hand spectroscope, calibrated from 400-700 μ in 10 μ divisions was used. A model, having a prism fitted to cover half of the slit was used, so that unknown and standard solutions could be examined simultaneously (Fig. 1.4). Provision was made, by a push-button switch, for the scale to be illuminated momentarily by light from a bezzle lamp attached to the scale tube by a rubber tube. The light was diffused by frosted glass plates contained in this tube.

A camera ("Praktica" Fx2, 35 mm. with a Meyer Optik Gorlitz 2.9 lens of 50 mm. focal length), fitted with a 2 diopetre supplementary lens was mounted directly in front of the eyepiece, but outside the light-proof box which housed most of the apparatus. A rubber seal provided a light-proof connection between the camera lens and the inside of the box. The excitation radiation was provided by an enclosed 125 watt mercury lamp fitted to the outside of the box (Fig. 1.5). The Wood's glass bulb restricts the radiation to mainly the 3650 \AA ⁰ mercury line. The visible light still transmitted was almost completely removed by a further Wood's glass filter, which was used as a window to the optical box.

The instrument was calibrated against mercury, neon, hydrogen, and sodium lines. In the 400 μ region the expected accuracy is within 1 μ , and in the 500 μ region within 5 μ . Standards for comparing known spectra with unknown ones were contained in screw-capped glass phials of 4 c.c. capacity, which were supported in a metal tube inclined at 45° and directly over the comparison prism of the spectrometer. The tube had a window in the upper end in order to allow the incident light to reach the solution and the emitted rays to reach the slit. The standards contained the amount of fluorescent substance which would give approximately the brightest spectrum; e.g. 3:4-benzopyrene, 5×10^{-4} mole/l.; anthracene, 10^{-3} mole/l., and 1:2-benzanthracene 5×10^{-4} mole/l.

The unknown was contained in a pyrex test tube supported in another metal tube with a window cut so that the incident light, emitted at right angles, passed directly through the slit. Aluminium foil was used as reflectors behind both standard and unknown solutions, to increase the intensity of radiation.

The solvent used was usually benzene, but unknowns were always examined in the same solvent as the standard materials. With solutions of the above concentration,

TABLE 1.1. MAXIMA (m μ) OF FLUORESCENCE BANDS OF
3:4-BENZOPYRENE.

Weigert ^a (acetone)	Chalmers ^b (alcohol)	Schoental ^c (light petroleum)	Cardon ^d (benzene)	Present Work. (benzene)
-	394	-	-	398 weak, B*
404	404.5	403	-	404 strong, N.
410	410	408	410	409 weak, N.
417	417	415	413	417 weak, N.
427	429	427	-	427 strong, B.
-	434	431	432	433 strong, B.
-	-	437	-	437 v. weak, N.
455	456	454	455	456 strong, B.
485	-	-	-	485 weak, B.

* B = Broad band; N = Narrow band.

^a Weigert and Mottram, Nature, 1940, 145, 895.

^b Chalmers, Biochem. J., 1938, 32, 271.

^c Schoental and Scott, J. Chem. Soc., 1949, 1683.

^d Cardon, Alvord, Rand, and Hitchcock, Brit. J. Cancer, 1956, 10, 485.

TABLE 1.2.

MAXIMA (m μ) OF FLUORESCENCE BANDS
OF PERYLENE.

Radulescu ^a (benzene)	Radulescu ^a (heptane)	Schoental ^b (light petroleum)	Present Work. (benzene)
446	440	438	445 B
475	465	465	475 B
505	498	497	502 B
537.5	535	-	536 B

^a Radulescu and Dragulescu, Bul. Soc. chim. Romania,
1935, 17, 9, 26, 35.

^b Schoental and Scott, J. Chem. Soc. 1949, 1683.

a spectrometer slit-width of 0.01 in., and an exposure of 1 min. at $f_{2.9}$, with Kodak Tri-X or Ilford HPS film was usually satisfactory. The scale was illuminated for approximately 0.5 sec.

With this apparatus, 3:4-benzopyrene (5×10^{-4} mole/l. in benzene) gave a fluorescence spectrum showing considerable fine structure. The positions of the maxima of the fluorescence bands are given in Table 1.1, which records the values obtained by previous workers. With weaker or impure solutions only the strong bands were normally detected.

Perylene showed maxima as recorded in Table 1.2.

CHAPTER II

AN EXAMINATION OF "SCHROETER TAR"

When tetralin is treated with aluminium chloride at low temperature, a complex mixture ("Schroeter tar") is obtained³⁵. Some of the distillation fractions have been found to be carcinogenic^{36a}. Hieger^{36b} showed that the fluorescence spectrum of the distilled tar was similar to that of other carcinogenic tars obtained from gasworks, and the pyrolysis of acetylene, yeast, muscle, hair, etc., and the presence of 3:4-benzopyrene has been presumed for many years. Schroeter's analysis of the tar showed that the mixture contained octahydroanthracene, octahydrophenanthrene, 6-4'-phenylbutyltetralin (I) and 2:6'-ditetrayl.³⁵ Cook and Hewett³⁷ have suggested that it may also contain some 5-4'-phenylbutyltetralin (II), which could conceivably give the carcinogenic hydrocarbon 3:4-benzopyrene (IV) by cyclodehydrogenation.

The distillation fractions of "Schroeter Tar" have now been examined for 3:4-benzopyrene. Several of the crude fractions gave diffuse fluorescence spectra corresponding to the fluorescence spectrum of this

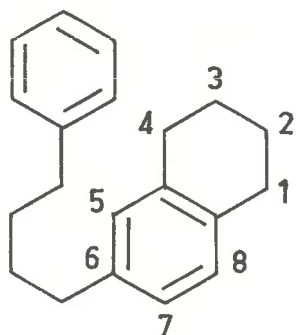

(I)

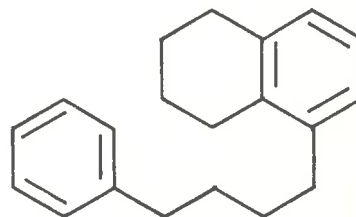

(II)

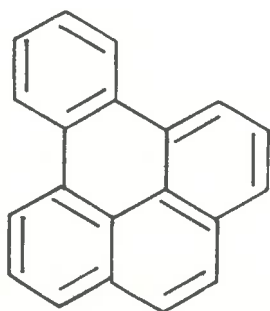

(III)

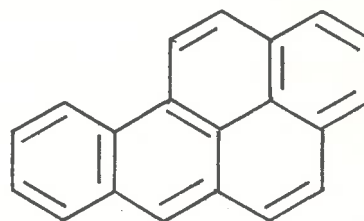

(IV)

hydrocarbon. Chromatography on alumina gave 3:4-benzopyrene from two fractions. The 6-4'-phenylbutyltetralin fraction, b.p. 230-240°/15 mm., was found to contain a small amount of the benzopyrene, but the higher fraction, b.p. 205-240°/0.5 mm., which approximately corresponds to the fraction which Kennaway^{36a} showed to be the most carcinogenic, has been found to contain as much as 4%

3:4-benzopyrene. A small amount of perylene was also found, but no conclusive evidence of 1:2-benzopyrene (III), despite the fact that this might be expected following cyclodehydrogenation of 6-4'-phenylbutyltetralin (I). Another hydrocarbon, which was not identified, was isolated from the highest fraction b.p. 245-300⁰/1 mm.

An attempt was made to detect 5-4'-phenylbutyltetralin (II) in "Schroeter Tar", but without success. Careful fractionation of the fraction b.p. 230-240⁰/15 mm., using a spinning band column gave 6-4'-phenylbutyltetralin (I) and 2:6'-ditetralyl in agreement with Schroeter³⁵; but the 5-isomer, if present, could not be separated. Gas-liquid chromatography also afforded no separation of isomers. Oxidation of a portion of the same fraction with potassium permanganate, esterification of the resulting acid with diazomethane, followed by chromatography, gave 1:2:4-tricarbomethoxybenzene as the only product, and no 1:2:3-tricarbomethoxybenzene (which would be formed by the oxidation of II.) could be detected.

These experiments do not eliminate the possibility that a small amount of 5-4'-phenylbutyltetralin (II) may be present. If it is present, it would be expected to cyclodehydrogenate to 3:4-benzopyrene under pyrolytic

conditions, and it was thought that it may be easier to detect this transformation. The fraction b.p. 230-240°/15 mm. from which essentially all the 3:4-benzopyrene had been removed, was accordingly pyrolysed at 360° and 600°. At the lower temperature only a trace of 3:4-benzopyrene was detected. Pyrolysis at 600° gave a complex tar containing a considerable amount of low boiling products. Analysis by distillation, gas-liquid chromatography, and chromatography on alumina enabled positive identification of naphthalene, 2-methylnaphthalene, and 2-ethylnaphthalene. Compounds with gas-liquid chromatographic retention times corresponding to toluene, ethylbenzene, styrene, propylbenzene, and other unidentified simple products were also observed. A compound having a phenanthrene-type ultra-violet absorption spectrum was isolated and 2:2'-dinaphthyl was also found in reasonable yield. 3:4-Benzopyrene was again present in only trace amounts; but perylene was isolated in 0.125% yield.

This work has therefore failed to show the presence of 5-4'-phenylbutyltetralin (II). Nevertheless, this does seem to be the most reasonable intermediate for the formation of the 3:4-benzopyrene in "Schroeter Tar". The explanation may be that the 5-4'-phenylbutyltetralin

is formed, and is so readily converted into 3:4-benzopyrene that the intermediate cannot be isolated.

It remained to be determined whether the proposed cyclodehydrogenation is brought about by the catalytic action of the aluminium chloride, or occurs during the distillation in the subsequent working up of the product. Undistilled "Schroeter Tar" was therefore examined. Cold sulphuric acid extraction of the undistilled tar, followed by chromatography on alumina of the benzene extract, gave a yellow hydrocarbon, apparently 1":2":3":4":5':6':7':8'-octahydro-8:9-benzonaphtho-(2':3'-3:4)pyrene (VII), but no 3:4-benzopyrene. The melting point and fluorescence spectrum of the octahydrobenzonaphthopyrene agree with the literature⁴⁵. There is a slight difference in the ultraviolet absorption spectrum (Fig. 2·1), and the spectrum of the compound isolated here, more closely resembles that of 3:4-benzopyrene, with a bathochromic shift of approximately 15 m μ , than previously reported. Dehydrogenation with palladium-charcoal gave 3:4-benzopyrene (VIII) whose melting point, fluorescence, and ultraviolet spectra (Fig. 2·2) was in agreement with the literature⁴⁵.

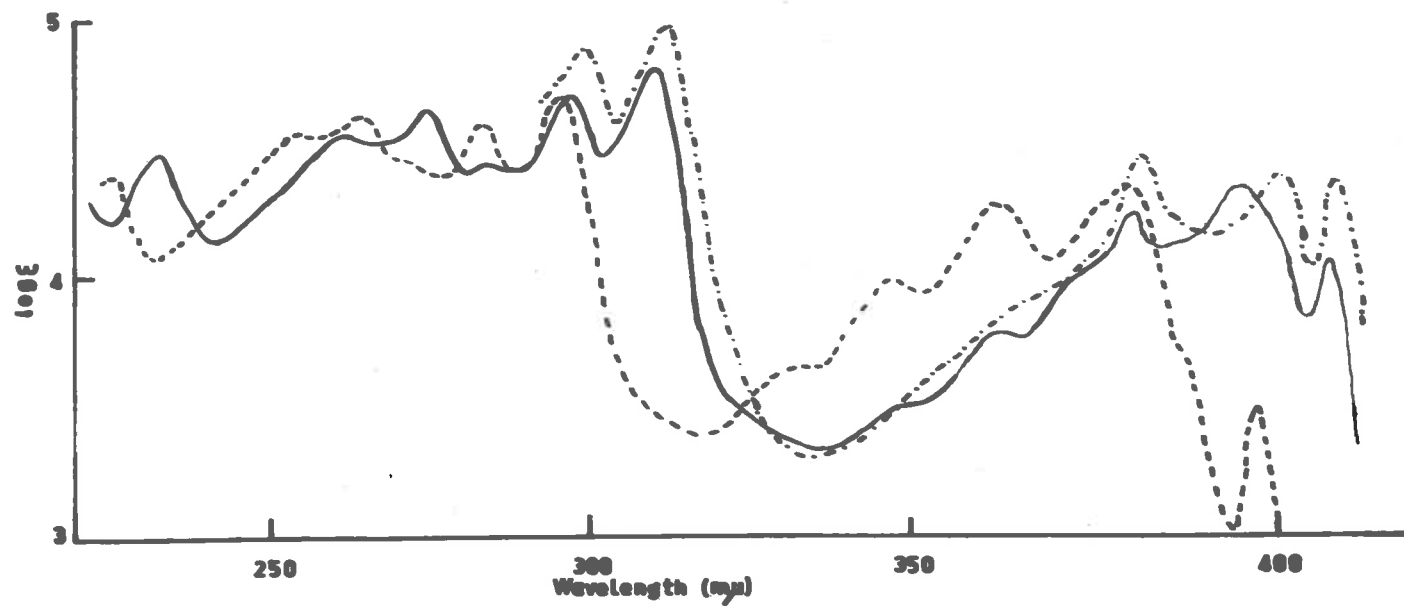

Fig. 2-1. 1^o:2^o:3^o:4^o:5^o:6^o:7^o:8^o-Octahydro-8:9-benzonaphtho-(2':3'-3:4)pyrene(?)
 (This work: —), and Grove (· · · ·); 3:4-benzopyrene (---).

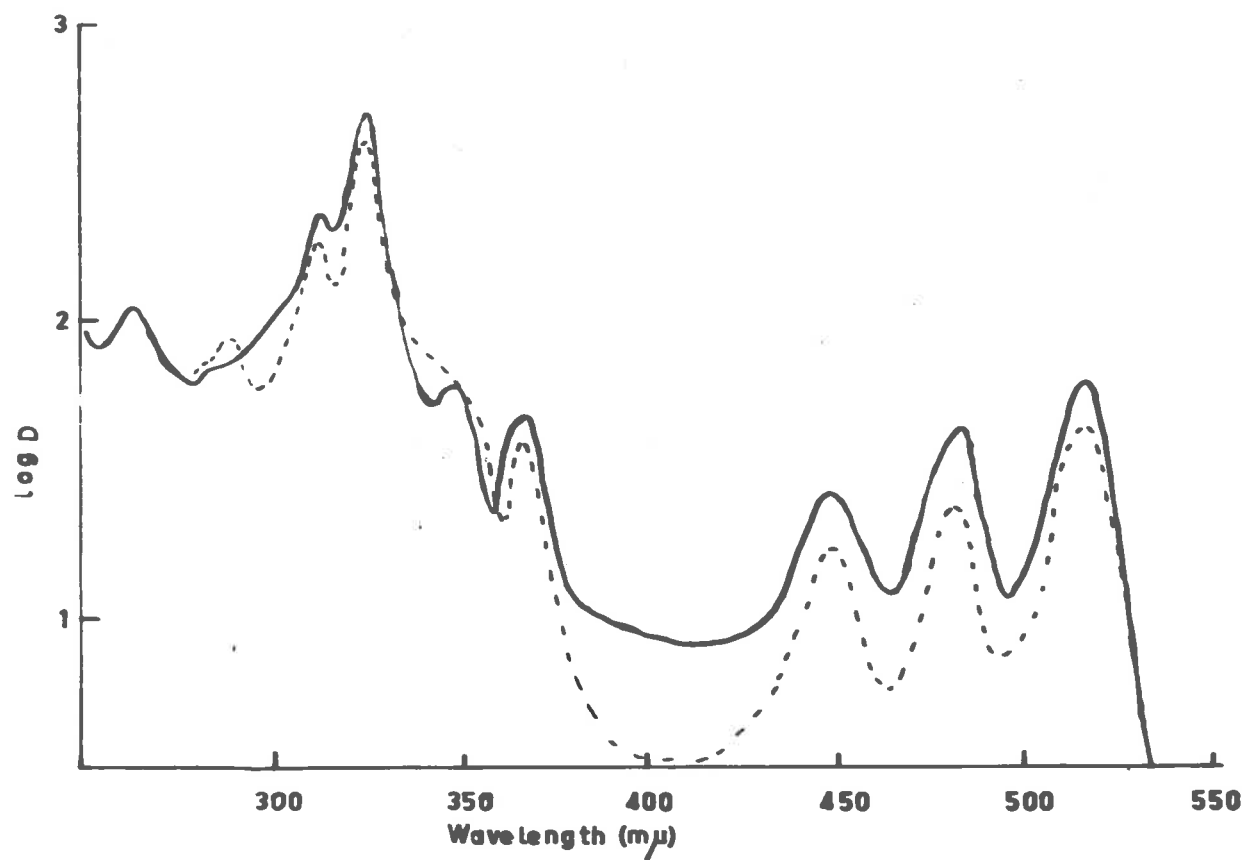
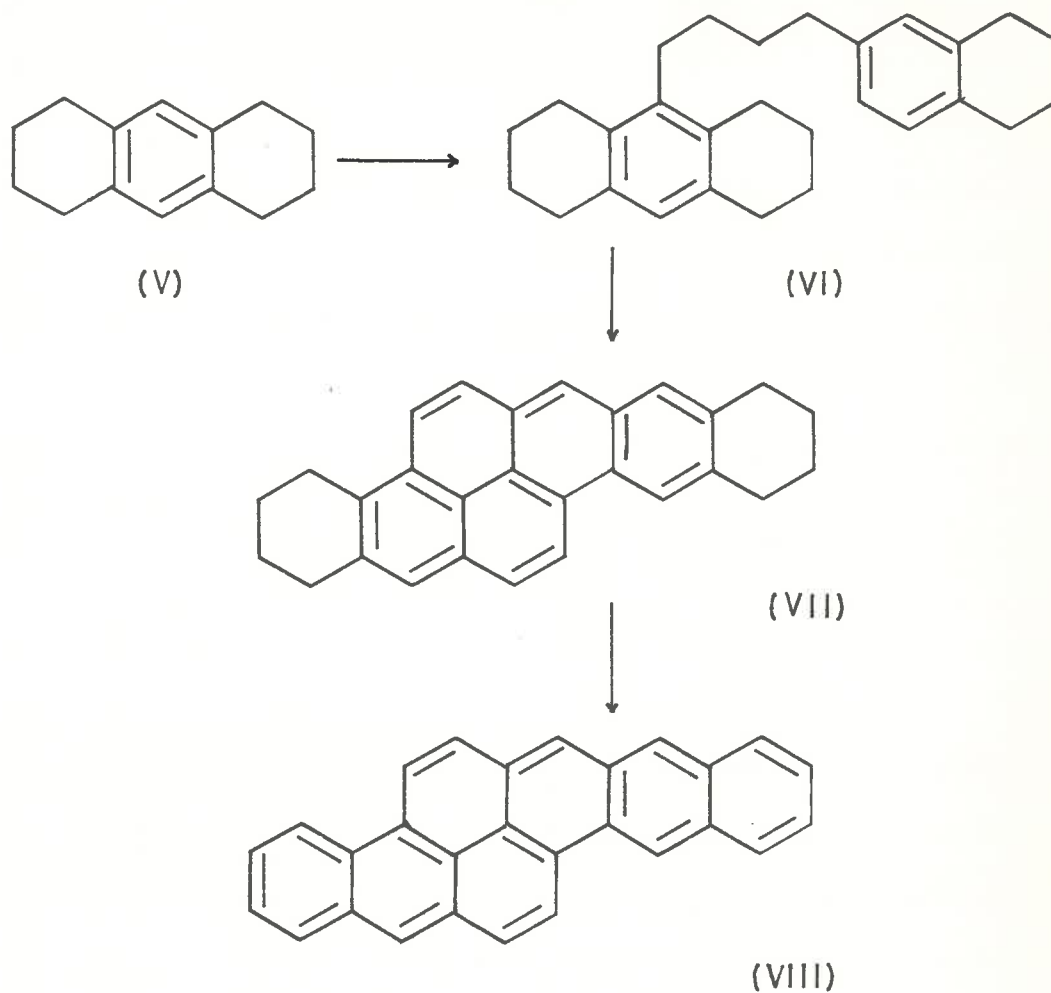

Fig. 2·2. 3:4-Benzo-8:9-(2':3'-naphtho)pyrene (This work: —);
(Grove: - - - -).



Grove⁴⁵ gives evidence that the octahydrobenzo-naphthopyrene is the unidentified yellow compound found by Schroeter³⁵ from the action of aluminium chloride on octahydroanthracene (V). In the present work this

compound could then be formed by the same mechanism (V, VI, VII) suggested by Grove. (cf. the proposed tetralin to 3:4-benzopyrene mechanism).

The material not extracted with sulphuric acid (see fraction B2 Fig. 2·3) was distilled, but only small amounts of 3:4-benzopyrene and perylene were detected after chromatography on alumina. Similarly, distillation of the early liquid fractions following chromatography of the sulphuric acid-soluble material (fraction B4 Fig. 2·3) gave very little 3:4-benzopyrene.

It seems likely, therefore, that the 3:4-benzopyrene in "Schroeter Tar" is not formed by the action of aluminium chloride, but is formed by the heat of distillation. It can also be said that the sulphuric acid used here for extraction, in some way rearranges or otherwise interferes with the precursor, and prevents the formation of 3:4-benzopyrene even on heating. This was supported by repeating the analysis on a smaller scale and by chromatographing the tar on alumina instead of extracting with sulphuric acid. As anticipated, distillation of the appropriate fractions gave 3:4-benzopyrene, so confirming the above conclusions.

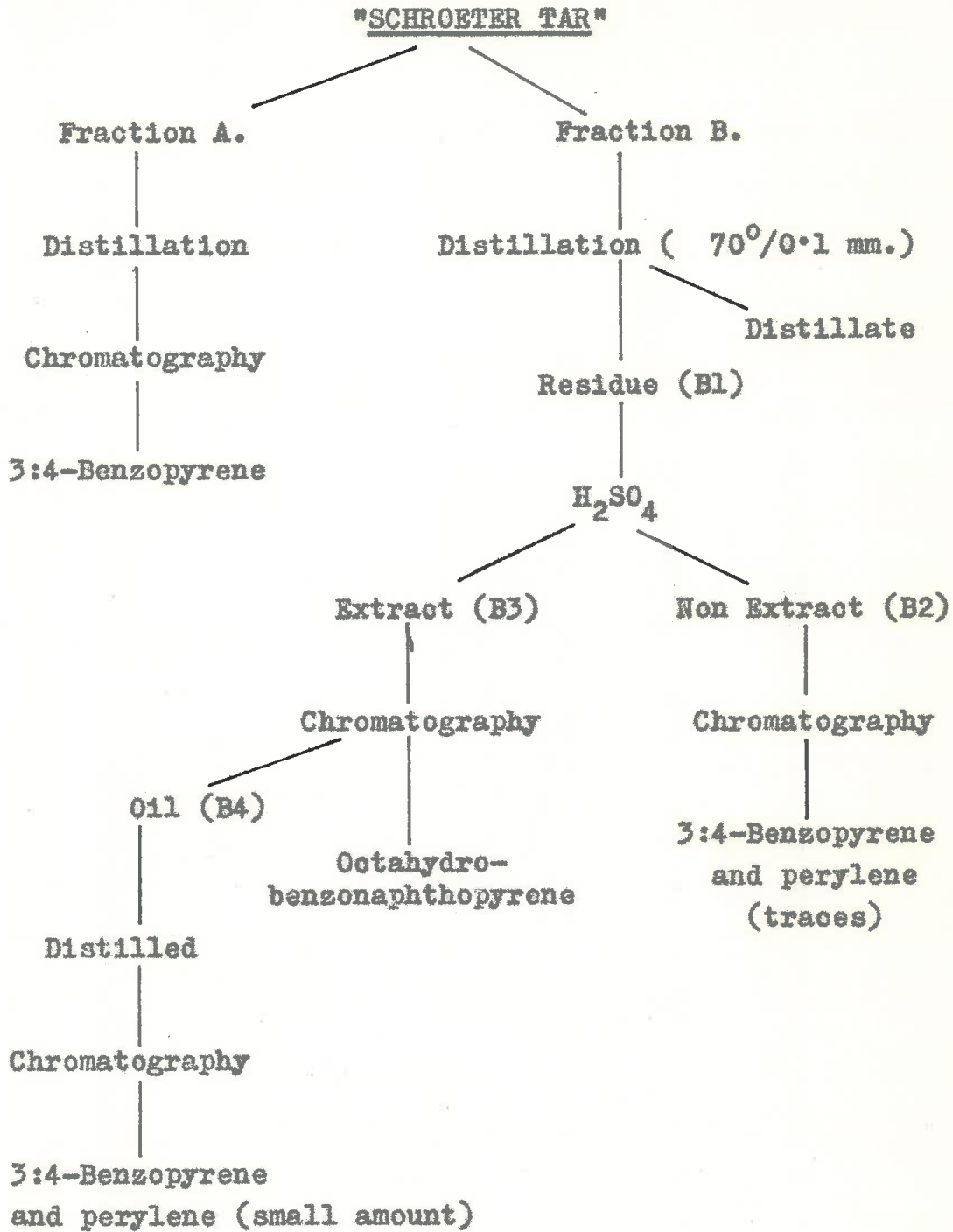

Fig. 2.3.

EXPERIMENTAL.

"Schroeter Tar".-- Tetralin (2.5 kg.) and aluminium chloride (50 g.) were stirred for 10 hr. at 50-70°. After pouring onto ice the tar produced was collected and distilled. On removal of the lower boiling fractions containing benzene, tetralin, octahydroanthracene and octahydrophenanthrene³⁵ the following fractions were distilled: (i) b.p. 230-240°/15 mm. (280 g.); (ii) b.p. 205-240°/0.5 mm. (75 g.); and (iii) b.p. 245-300°/1 mm. (71 g.). All fractions having b.p. greater than 120°/15 mm. showed fluorescence bands corresponding to 3:4-benzopyrene.

Analysis of Fraction (i).-- The crude tar (63 g.) from this fraction was chromatographed in hexane on alumina (40 x 5 cm.). Elution with hexane (1 l.) brought through the bulk of the tar, mainly consisting of 6-4'-phenylbutyltetralin, which showed only a very faint fluorescence spectrum of 3:4-benzopyrene. However, further elution with benzene-hexane (1:2), gave eight fractions (each of 70 c.c.) having fluorescence ranging from blue-violet in the early fractions, to green-blue, and then back to blue-violet in the later fractions.

Fractions 1, 2, 6, 7 and 8 showed strong fluorescence bands of 3:4-benzopyrene, and fractions 3, 4, and 5 somewhat weaker bands owing to quenching, together with three other bands which were identical with those of perylene. Removal of the solvent gave crude 3:4-benzopyrene (60 mg.). Recrystallisation from ethanol gave the substantially pure product as yellow needles, m.p. 174-176°, not depressed by admixture with an authentic sample (lit.⁴⁶ 176-177°). Its ultraviolet absorption spectrum (in ethanol) gave the following maxima (μ) and $\log \epsilon$ values (in parenthesis), in good agreement with the literature^{46,47} 226 (4.40); 255 (4.58); 265 (4.65); 274 (4.44); 284 (4.62); 296 (4.73); 331 (3.65); 347 (4.04); 364 (4.30); 384 (4.37); 404 (3.50). A maximum at 434 μ (2.78) was identical with that of perylene (lit.⁴⁸ 434 μ). From the absorption spectrum this seems to be present in less than 1%.

Analysis of Fraction (11).- The tar (55 g.) was chromatographed in hexane on alumina (35 x 5 cm.). Elution with hexane (2 l.) brought through the main product as a pale yellow oil with an intense violet fluorescence. Further elution with benzene-hexane (1:2) brought through a very broad yellow band which was

practically non fluorescent on the column, but which gave a green-yellow fluorescence in solution. Eight fractions (each of 175 c.c.) were collected and removal of the solvent gave yellow crystals of crude 3:4-benzopyrene (2.1 g.). Fractions 2 - 5, which contained most of the material, were combined and recrystallised from ethanol. A further three recrystallisations gave the substantially pure product m.p. 174-175^o, not depressed by admixture with an authentic sample. (Found: C, 95.0; H, 5.0. C₂₀H₁₂ requires C, 95.2; H, 4.8%). The trinitrobenzene complex had m.p. 223-224^o (lit. 226-227^o corr.). (Found: C, 67.15; H, 3.2. C₂₆H₁₅N₃O₆ requires C, 67.1; H, 3.2%). Absorption spectroscopy showed perylene to be present to the extent of less than 1%.

Analysis of Fraction (iii).- This fraction (71 g.) was chromatographed as above. The fractions which were eluted with benzene-hexane (1:2) (1.5 l.) were combined, the solvent removed, and the residue extracted in benzene with cold sulphuric acid⁴⁹. The acid extract was poured onto ice and extracted with benzene in a continuous liquid extractor for 12 hr. After washing with sodium bicarbonate solution, then water, and finally drying, the benzene was evaporated. Chromatography on alumina,

and elution with benzene-hexane (1:2) gave several orange fractions which were evaporated. The residues were recrystallised from ethanol to give orange-brown prisms m.p. 255-257°. Its ultraviolet absorption spectrum had maxima at 220, 246, 255, 269, 297, 310, 323, 354, 374, 396, 422, 448, and 456 (infl.) μ m. (Fig. 2.4)

Attempted Isolation of 5:4'-Phenylbutyltetralin from "Schroeter Tar".- (1) By fractionation. An attempt was made to fractionate the crude tar (70 g., b.p. 230-240°/15 mm.) using a spinning band column. By plotting both boiling point and refractive indices of 2 c.c. fractions against the amount distilled, the distillate could be divided into three fractions: (a) the forerun (6 c.c.) b.p. 230-235°/15 mm.; (b) the main fraction (36 c.c.) (which had both a slowly rising boiling point, i.e. 136-140°/15 mm., and refractive index, η_D^{17} 1.5670-1.5720); and (c) a compound (24 c.c.) which solidified as colourless plates and identified by its m.p. 54-54.5° (Schroeter gives m.p. 53-54°) as 2:6'-di-tetralyl. Fraction (b) which still exhibited a pale violet fluorescence in visible light, and which was intensely violet in ultraviolet light, showed identical infrared spectra throughout the fraction.

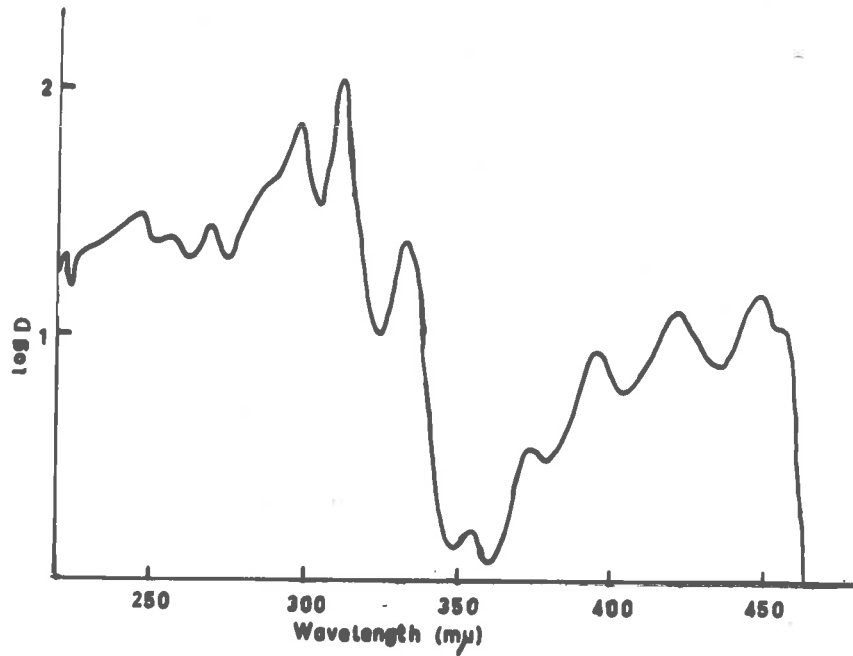

Fig. 2.4. Unknown from fraction (111).

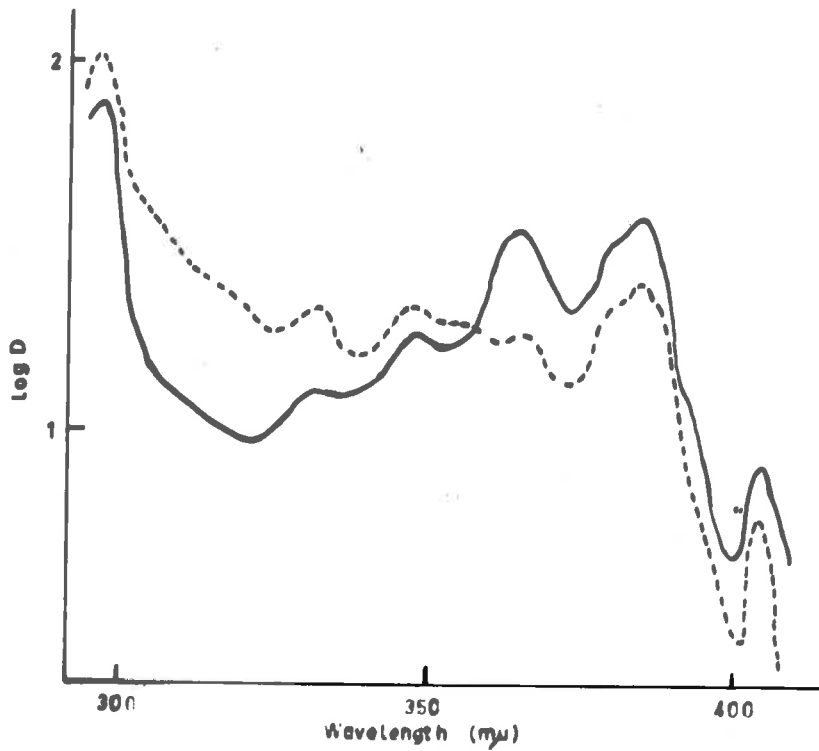

Fig. 2.2. 3:4-Benzopyrene (authentic: —);
(This work: - - -).

(ii) By gas-liquid chromatography. Gas-liquid chromatography, using both the instrument built in this laboratory⁴¹ and a Griffin Vapour Phase Refractometer, of the fraction b.p. 230-240^o/15 mm., failed to separate the two isomers of phenylbutyltetralin.

(iii) By oxidation. Oxidations with (a) potassium permanganate, and (b) chromium trioxide and acetic acid, were carried out on the redistilled tar, b.p. 230-240^o/15 mm. (13 g. and 5.2 g. respectively) by the method of Schroeter³⁵, except that with (a) after acidification with sulphuric acid the mixture was extracted with ether, the ethereal solution dried, and then treated with diazomethane. However, the product was 1:2:4-tricarbo-methoxybenzene and no 1:2:3-tricarbomethoxybenzene expected from oxidation of the α -isomer, could be detected in the resulting oily product.

With oxidation by method (b) no separation of 2:4-dinitrophenylhydrazones of the ketone(s) formed could be effected by chromatography in chloroform on kieselguhr and bentonite (1:4).

Pyrolysis Reactions.- (i) Distillation. The fraction (b) from the spinning band distillation (27 g.), which showed strong but diffuse fluorescence bands of

3:4-benzopyrene (Plate 2·1a) was chromatographed on alumina (40 x 5 cm.). Elution with hexane (800 c.c.) brought through the bulk of the material as a non-fluorescent (in visible light) colourless oil. Further elution with benzene-hexane (1:2) (8 fractions of 70 c.c.) gave 3:4-benzopyrene in the last three fractions, identified by its fluorescence (Plate 2·1b) and absorption spectra (Fig. 2·5) (maxima at 404, 384, 365, 347, and 332 m μ .). The calculated amount present from the absorption curve was less than 0.5 mg.

(ii) At 360°. Fraction (1) (2 g.) b.p. 230-240°/15 mm., from which the 3:4-benzopyrene had been removed by chromatography was refluxed for 1 hr. Chromatography of the product on alumina gave small amounts (ca. 0·5 mg.) of 3:4-benzopyrene and perylene, as estimated from the ultraviolet absorption spectrum. Three maxima (at 331, 316, and 299 m μ) suggested the presence of a small amount of 1:2-benzopyrene also.

(iii) At 600°. Fraction (1) from which the benzopyrene had been removed (20 g.) was vapourised at the rate of 1 drop/15 sec. and passed with nitrogen (1 c.c./sec.) through a silica tube (36 x 1 in.) packed with porcelain chips ($\frac{3}{8}$ - $\frac{1}{4}$ in.) heated to 600°.

Distillation of the resulting reddish-brown tar (15 g.) gave 8 fractions and a residue as follows:- F1, b.p. 80° (0.25 g.); F2, b.p. 80-120° (0.5 g.); F3, b.p. 80-110°/21 mm. (3 g.); F4, b.p. 110-120°/21 mm. (2.5 g.); F5, b.p. 120-140°/21 mm. (0.5 g.); F6, b.p. 100-150°/1.2 mm. (3 g.); F7, b.p. 150-180°/1.2 mm. (2 g.); F8, b.p. 180-220°/1.2 mm. (1 g.); and the residue (2 g.).

Gas phase chromatography* of fractions F1 and F2 gave peaks with retention times corresponding to toluene (0.1 g.), ethylbenzene (0.3 g.), styrene or o-xylene (0.25 g.), and n-propylbenzene (0.1 g.) (Table 2.1). (The amounts were calculated from the areas under the peaks). The third compound was found to decolourise bromine water.

Similarly, gas phase chromatography of fraction F3 gave four peaks, the last two of which corresponded to naphthalene and 2-methylnaphthalene. (Table 2.2). Collection of the fractions confirmed the presence of naphthalene (1.62 g.), m.p. and mixed m.p. 79-80°, and 2-methylnaphthalene (0.54 g.); its infrared spectrum showed maxima at 5.18, 5.38, 5.53, 5.66, 5.91, 6.08, 6.23, 6.98, 7.12, 7.28, 7.36, 7.55, 7.89, 8.10, 8.32, 8.53,

* The instrument built in this laboratory used here.

TABLE 2-1

FRACTION F1 & 2.

Column: Apiezon M on 100-150 mesh Celite;

Temperature 115⁰; Inlet pressure 760 mm.;

Outlet pressure 760 mm.; N₂ flow rate, 2.5 l./hr.

<u>UNKNOWN</u>			<u>STANDARD</u>		
Peak.	RT	RTR	Inference	RT	RTR
1	6 mm.	1	Toluene	6.3 mm.	1
2	11 "	1.8	Ethylbenzene	11.4 "	1.8
3	14 "	2.7	o-Xylene or styrene	16.4 "	2.6
4	22.5 "		Propylbenzene(?)		

TABLE 2-2

FRACTION F 3.

Column: Apiezon L on 40-80 mesh Celite;

Temperature 192⁰; Inlet pressure 423 mm.;

Outlet pressure 5 mm.; N₂ flow rate, 1.1 l./hr.

<u>UNKNOWN</u>			<u>STANDARD</u>		
Peak.	RT	RTR	Inference	RT	RTR
1	3.4	.5	Unknown -X		
2	5.3	.77	Unknown -Y		
3	6.75	1	Naphthalene	6.8	1
4	10.9	1.6	2 Me-naphthalene	11.0	1.6
5	12 (infl.)		1 Me-naphthalene(?)	12.1	

RT = Retention time. RTR = Retention time ratio.

8.67, 8.76, 8.89, 9.64, 10.44, and 14.34 μ essentially in agreement with the literature⁵⁰. It also showed maxima at 5.90, 6.85, 7.22, 7.42 (infl.), and 9.28 μ probably indicative of 1-methylnaphthalene. This is supported by the presence of a shoulder on the main peak of the chromatography curve as expected for a mixture of methylnaphthalenes. The unidentified compounds, unknown -X (0.54 g.) and unknown -Y (0.27 g.) were collected. Infrared analysis of unknown -X suggested a mixture of two trisubstituted benzene compounds containing some methyl substitution. This was indicated by six absorption maxima at 5.09, 5.19, 5.25, 5.33, 5.42 and 6.02 μ from combination tone vibrations, and by a peak at 3.54 μ denoting methyl absorption in the C - H stretching region. There was insufficient of unknown -Y for identification.

Fractions F4-5 showed the presence of naphthalene (0.62 g.), methylnaphthalenes (1.25 g.), and 2-ethylnaphthalene (0.9 g.). The latter was collected, and showed maxima in the infrared at 5.20, 5.42, 5.61, 5.85, 6.10, 6.23, 7.88, 8.30, 8.55, 8.67, 8.76, 8.89, 9.37 (infl.), 9.47, 9.81, 10.28 (infl.), 10.39, 10.56, 11.26, 11.73, 12.24, 12.79, and 13.11 μ in agreement with the literature⁵⁰. In the region 6.5 - 8 μ the maxima

corresponded with those of 1-ethylnaphthalene. A fourth gas phase chromatography fraction (0.07 g.) could not be identified.

Fraction F6 was chromatographed on alumina (3 x 15 cm.) in hexane. Elution with this solvent gave five fractions (each of 60 c.c.) all of which gave on evaporation of the solvent a white solid. Recrystallisation from ethanol gave fine colourless prisms m.p. 150-157⁰. Its ultra-violet absorption spectrum (Maxima at 250, 252, 276, 288, 300, 323, 340, and 358 m μ) suggested a phenanthrene derivative (Fig. 2.6), but it was not identified.

Chromatography of fractions F7-8 on alumina and elution with hexane and benzene-hexane (1:2), gave 2:2'-dinaphthyl (1 g.), (identified by m.p., mixed m.p., and ultraviolet spectrum). Trace amounts of 3:4-benzopyrene and perylene were indicated by fluorescence spectroscopy.

The residue was chromatographed on alumina in benzene to remove black intractable materials. The resulting eluant was treated with cold sulphuric acid⁴⁹ giving an extracted portion, F11, and a non-extracted portion, F12. Evaporation of the solvent from F11, followed by chromatography on alumina, gave perylene (20 mg.) shown by absorption spectroscopy (maxima at 245,

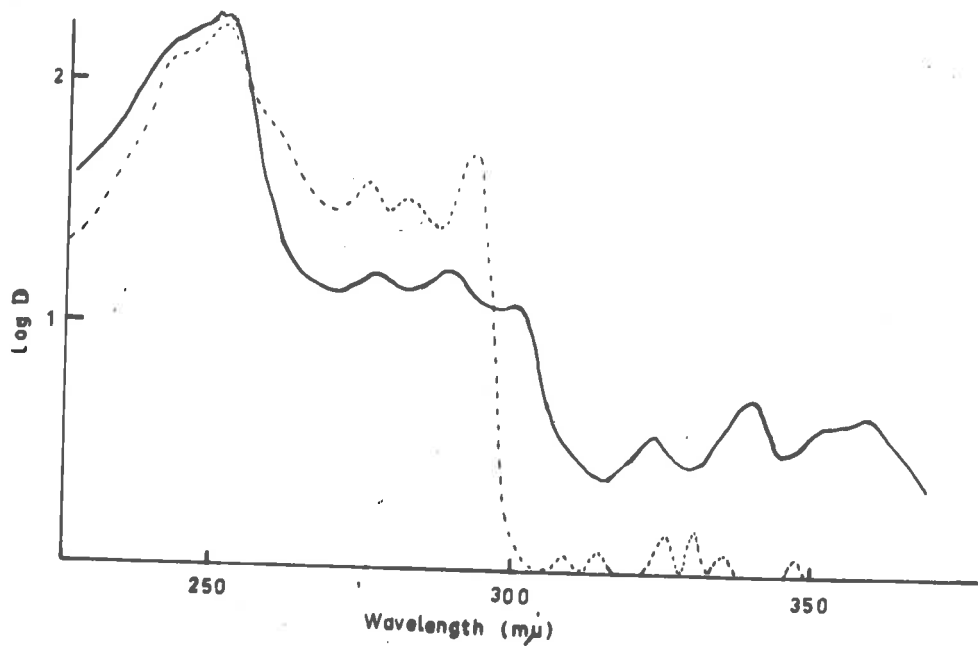

Fig. 2.6. Unknown compound from fraction F6 (—);
Phenanthrene (- - -)

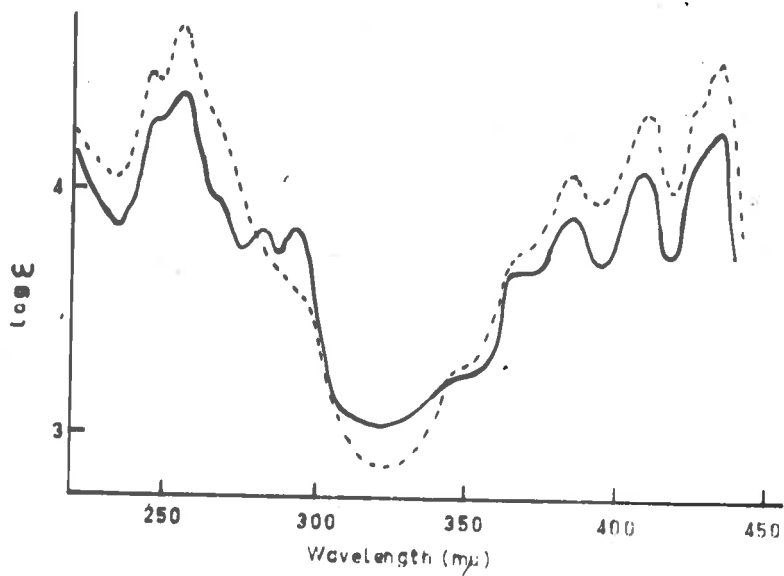

Fig. 2.7. Perylene from fraction F11 (—);
authentic (- - -)

252, 386, 408, 426 (infl.) and 435 μ). (Fig. 2.7). Its fluorescence spectrum also showed the presence of a small amount (1 mg.) of 3:4-benzopyrene. Similar treatment of F12 gave 2:2'-dinaphthyl (1 g.). Recrystallisation twice from ethanol gave the pure product m.p. 182-184° (lit.⁵¹ 186° corr.) and showed maxima (μ) and log values (in parenthesis) at 231 (4.12), 254 (4.94), and 304 (4.25). (Found: C, 94.5; H, 5.5. Calc. for C₂₀H14: C, 94.5; H, 5.6%).

Analysis of Undistilled "Schroeter Tar".- "Schroeter Tar" prepared from tetralin (2 kg.) and aluminium chloride (40 g.) was divided into two equal portions. Portion A was distilled as above. Chromatography on alumina of the appropriate fractions gave 3:4-benzopyrene (0.65 g.).

The tetralin and benzene were removed from portion B by distillation up to a temperature not greater than 70°/0.1 mm. The residue (300 g.), in an equal amount of benzene, was cooled to 0° and vigorously stirred while sulphuric acid (200 c.c.) was added at such a rate that the temperature did not rise above 5°. Stirring was continued for 15 min. and the acid layer removed. The extraction was repeated with 150, 100 and 50 c.c. lots of acid. The combined extracts were added with stirring

to ice (1 kg.), extracted with four lots of benzene and the combined benzene extracts washed with water, sodium bicarbonate and water respectively, then finally dried over calcium chloride. The benzene was removed and the residual tar (17 g.) chromatographed in hexane on alumina (20 x 3 cm.).

Elution with hexane brought through most of the product, and removal of the solvent gave a viscous oil B4 (Fig. 2.3). Further elution with benzene-hexane (1:2) gave a yellow compound (0.3 g.). Recrystallisation three times from cyclohexane gave 1ⁿ:2ⁿ:3ⁿ:4ⁿ:5^r:6^r:7^r:8^r-octahydro-8:9-benzonaphtho-(2^r:3^r-3:4) pyrene (?) as bright yellow plates m.p. 309-311^o (silicone bath) (lit.⁴⁵ 320^o). (Found: C, 92.8; H, 6.8. Calc. for C₂₈H₂₄: C, 93.3; H, 6.7%). Its fluorescence spectrum (Plate 2.1c) had maxima at 420, 445, 475, and 499 in agreement with the literature⁴⁵. The ultraviolet absorption spectrum (in cyclohexane) showed maxima (mμ) and log ε values (in parenthesis) at; 233 (4.49), 262 (4.56), 275 (4.66), 297 (4.72), 311 (4.84), 350 (3.69), 366 (3.80), 374 (4.25), 420 (4.36), 416 (4.06) in agreement with the literature⁴⁵, except the maximum at 420 mμ. (Fig. 2.1).

The octahydrobenzonaphthopyrene (58 mg.) was dehydrogenated by refluxing it in *p*-cymene (10 c.c.) with 10% palladium-charcoal (50 mg.) for 6 hr. The red residue remaining after removal of the solvent was chromatographed on alumina in benzene. Recrystallisation from benzene gave 3:4-benzo-8:9-(2':3'-naphtho)pyrene as scarlet plates m.p. 334-337° (lit.⁴⁵ 338-339°). Its ultraviolet absorption spectrum and its fluorescence spectrum with maxima at 262, 311, 324, 348, 366, 448, 482 and 515 m μ (Fig. 2.2) and 528, 565 and 612 m μ (Plate 2.1d) respectively, were in agreement with the literature⁴⁵.

The material B2 (Fig. 2.3) not extracted by the sulphuric acid, was washed with sodium bicarbonate, water, dried, and distilled. The material b.p. 210°/0.9 mm. was removed, and the residue chromatographed on alumina. Some fractions showed the fluorescence bands of 3:4-benzopyrene and perylene. This was confirmed by ultraviolet absorption spectroscopy, and by their R_f values from chromatography on acetylated paper. It was estimated that only a small amount of each was present.

Distillation, chromatography and spectral analysis in a similar manner of the fractions b.p. 260-320°/19 mm. of the oil B4 (Fig. 2.1) also gave only a few mg. of 3:4-benzopyrene and perylene.

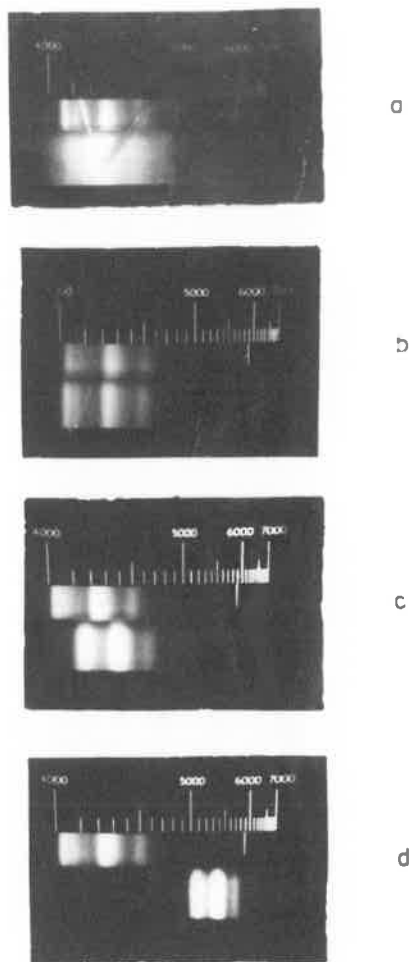

Plate 2.1. (a) Crude 3:4-benzopyrene fraction; (b) purified 3:4-benzopyrene; (c) 1^w:2^w:3^w:4^w:5^l:6^l:7^l:8^l-octahydro-8:9-benzonaphtho-(2^l:3^l-3:4)pyrene(?); (d) 3:4-benzo-8:9-(2^l:3^l-naphtho)pyrene. (The upper spectra are all 3:4-benzopyrene).

CHAPTER III

THE SYNTHESIS AND PYROLYSIS OF 1-4'-PHENYLBUTYLNAPHTHALENE
AND RELATED COMPOUNDS.

PART I.

The Pyrolysis of 1-4'-Phenylbutylnaphthalene.

5-4'-Phenylbutylnaphthalene (I) can be considered as a possible intermediate for the formation, at high temperatures, of 3:4-benzopyrene (see Chapters I and II). This could involve two mechanisms:-

- (1) A primary cyclisation followed by dehydrogenation of the tetralin ring and the butyl linkage.
- (2) Dehydrogenation of either the tetralin ring, or the butyl linkage, or both, to give 1-4'-phenylbuta-1:3-dienylnaphthalene (II), or 1-4'-phenylbuta-1:3-dienylnaphthalene (III), followed by cyclisation.

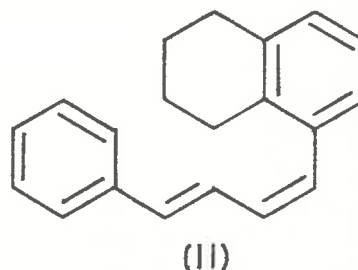
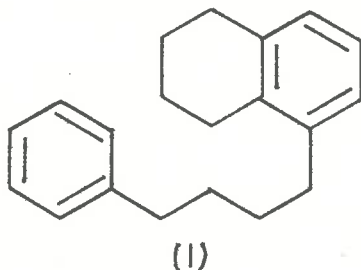

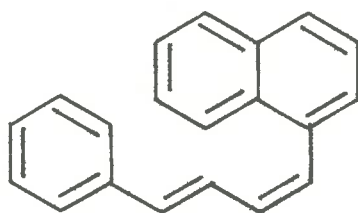

(III)

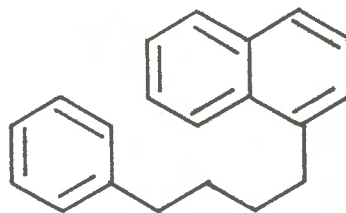

(IV a)

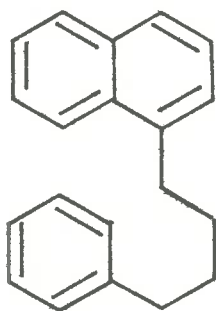

(IV b)

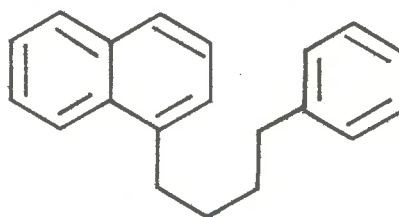

(IV c)

Cyclodehydrogenation clearly can take place in several ways, i.e. in the sense (IVa) to give 3:4-benzopyrene, in the sense (IVb) to give 1:1'-dinaphthyl or perylene, or in the sense (IVc) to give 1-phenylphenanthrene.

1-4'-Phenylbutylnaphthalene has now been synthesised and pyrolysed under varying conditions. All of the above cyclodehydrogenation products have been identified in the tars formed. Cyclodehydrogenation could conceivably occur so as to give compounds containing five membered

rings. However, none of these were found. When heated at 360° , 1-4'-phenylbutylnaphthalene was recovered essentially unchanged; however, ultraviolet and fluorescence spectra indicated that small amounts of 3:4-benzopyrene and perylene were present. On heating at 360° with palladium-charcoal as a catalyst the phenylbutylnaphthalene gave a 63% yield of 1-phenylphenanthrene. Fluorescence spectra indicated the presence of only very small amounts of 3:4-benzopyrene and perylene. Similar results were found using activated charcoal itself except that the yield of 1-phenylphenanthrene (8%) was much lower, and the yield of perylene (0.3%) greatly increased. No 3:4-benzopyrene could be detected. However, refluxing phenylbutylnaphthalene at 360° with palladium-asbestos gave no 1-phenylphenanthrene, but did give a small amount of benzopyrene and perylene and another compound with a chrysene type ultraviolet absorption spectrum. If this were 6:7-dihydro-3:4-benzopyrene it would be expected to have a spectrum similar to 5-ethylchrysene. Although the main maximum (268 m μ) was the same as for 5-ethylchrysene the very impure nature of the isolated product precluded any definite identification.

The observation that using palladium-charcoal or

charcoal itself as a catalyst a far greater yield is obtained of 1-phenylphenanthrene than the other cyclo-dehydrogenation products (at 360⁰) requires some comment. The catalyst may be expected to increase the yields of each possible cyclodehydrogenation product. If the dehydrogenation is a radical reaction (which is a reasonable assumption at these temperatures), then the most reactive positions will be those adjacent to the aromatic rings⁵²; viz. those shown by an asterisk in (V), (VI), and (VII). Cyclisation is then more likely to occur in (VI) and (VII) as these involve an active position. It would also be expected that cyclisation to a naphthalene nucleus (as with VII) would occur far more readily than to a benzene nucleus (as with VI)⁵³. On this reasoning alone, then, the yields should be in the order (VII)>>(VI) >(V).

Other factors are undoubtedly involved, including the fact that the cyclisation of one ring only is required in the formation of 1-phenylphenanthrene. However, this satisfactorily explains the yields with charcoal as catalyst, and to a lesser extent with palladium-charcoal. As the yields of perylene and 3:4-benzopyrene when palladium-asbestos was used were of the same order as those obtained by the pyrolysis at 360⁰ without any catalyst,

palladium-asbestos appears to be ineffective as a catalyst. The larger surface area of the charcoal may be involved in an explanation of this anomaly.

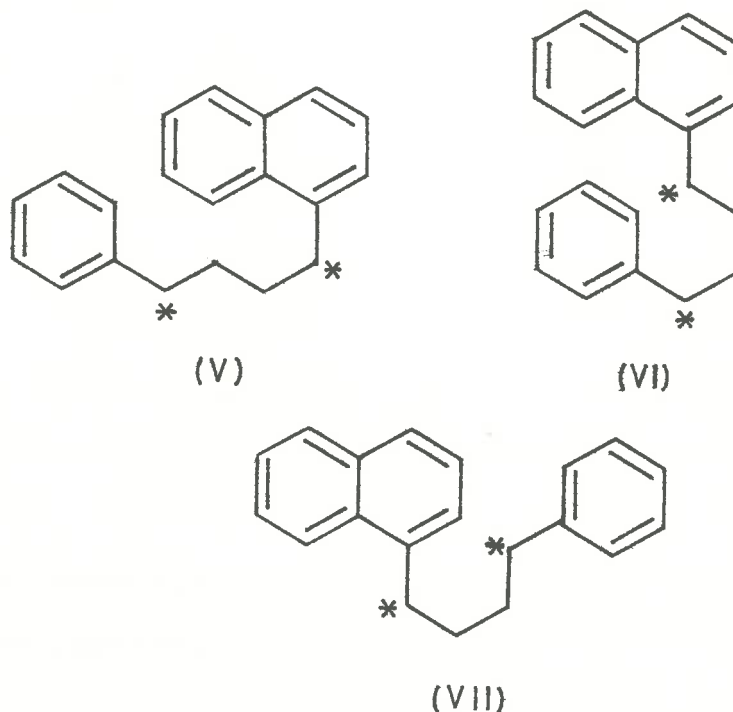

Pyrolysis of the phenylbutylnaphthalene at 600° was carried out by passing the liquid through a silica tube packed with porcelain chips heated in the electric furnace described in Chapter I. Low boiling substances produced by cracking (toluene, naphthalene, and 1-methylnaphthalene) were removed by distillation from the resulting tar. The residue was submitted to chromatography on alumina and the

various fractions analysed using ultraviolet and fluorescence spectra. These techniques showed the presence of 1:1'-dinaphthyl, pyrene, perylene and 3:4-benzopyrene in small yield. The mechanism of the formation of these compounds, except that of pyrene, which is obviously formed by secondary reactions involving the substances produced by cracking (e.g. styrene), have been discussed above.

The tar formed at 700° was shown, in the same way, to contain similar products, but with a much larger yield (40%) of naphthalene due to the greater amount of cracking at the higher temperature. However, at 500° using an unpacked pyrex tube unchanged starting material was mostly recovered. A comparison of the products obtained and their yields, in these pyrolyses, is given in Table 3-1.

For the synthesis of 1-4'-phenylbutylnaphthalene, ethyl β -benzoylpropionate was esterified with ethanol and sulphuric acid, and then reduced with "copper chromite" and hydrogen to ethyl-4-phenylbutyrate*. Further reduction

* Adkins, Wojcik, and Covert⁵⁴ describe this reduction as proceeding right through to the alcohol; however, with the apparatus used (maximum pressure obtainable was 2500 lbs./sq.in.) only the carbonyl function was reduced.

TABLE 3.1

PYROLYSIS PRODUCTS OF
1-4'-PHENYLBUTYLNAPHTHALENE.

Product	Yield %						
	360	360 (C)	360 (Pd/C)	360 (Pd/Asb)	500 (Un- pack- ed)	600	700
Recovered	75	50	sa	50	70	-	-
Toluene, etc.	-	sa	sa	25	-	25	10
Naphthalene	-	5	-	-	-	2	40
1 Me-Naphthalene	-	sa(?)	-	-	-	27%	(?)
Dinaphthyl	-	-	-	-	-	0.4%	(?)
1-Phenyl- phenanthrene	-	7.5	63	-	-	-	-
Pyrene	-	-	-	-	-	0.2	-
Perylene	0.05	0.3	sa	0.04	-	0.06	(?)
3:4-Benzopyrene	0.05	-	sa(?)	0.08	(?)	0.2	0.1
F.S. 412, 438, 465.	-	-	-	sa	sa	sa	0.02
Unidentified	sa	sa	sa	12.5	sa	20	20

F.S. = Fluorescence Spectrum;

sa = small amount.

with lithium aluminium hydride gave 4-phenylbutan-1-ol in good yield. This was converted to the bromide (VIII) with phosphorus pentabromide or with phosphorous tribromide. The tertiary alcohol (IX) was formed from the reaction of the Grignard complex, or lithio-derivative, of the bromide, and 1-tetralone. Dehydration of the alcohol, which occurred very readily, could conceivably give either a compound with an endocyclic (X), or exocyclic (XIV) double bond. Ozonisation of the product, and examination of the neutral fraction (presumably XII) by infrared spectroscopy showed two carbonyl bands. After treatment with acidified 2:4-dinitrophenylhydrazine no carbonyl bands could be detected. However, regeneration of the carbonyl compounds with pyruvic acid gave a compound which contained only one (aldehydic) carbonyl group. Evidently the action of the acidified 2:4-dinitrophenylhydrazine on (XII) resulted in intramolecular dehydration to the dinitrophenylhydrazone of the indene aldehyde (XII). A similar intramolecular dehydration to indene-2-aldehyde has been reported by Braun and Zobel⁵⁵.

This evidence indicates that the unsaturated compound is the dihydronaphthalene derivative (X). Dehydrogenation of this compound with palladium-charcoal in p-cymene gave the desired phenylbutylnaphthalene (XI).

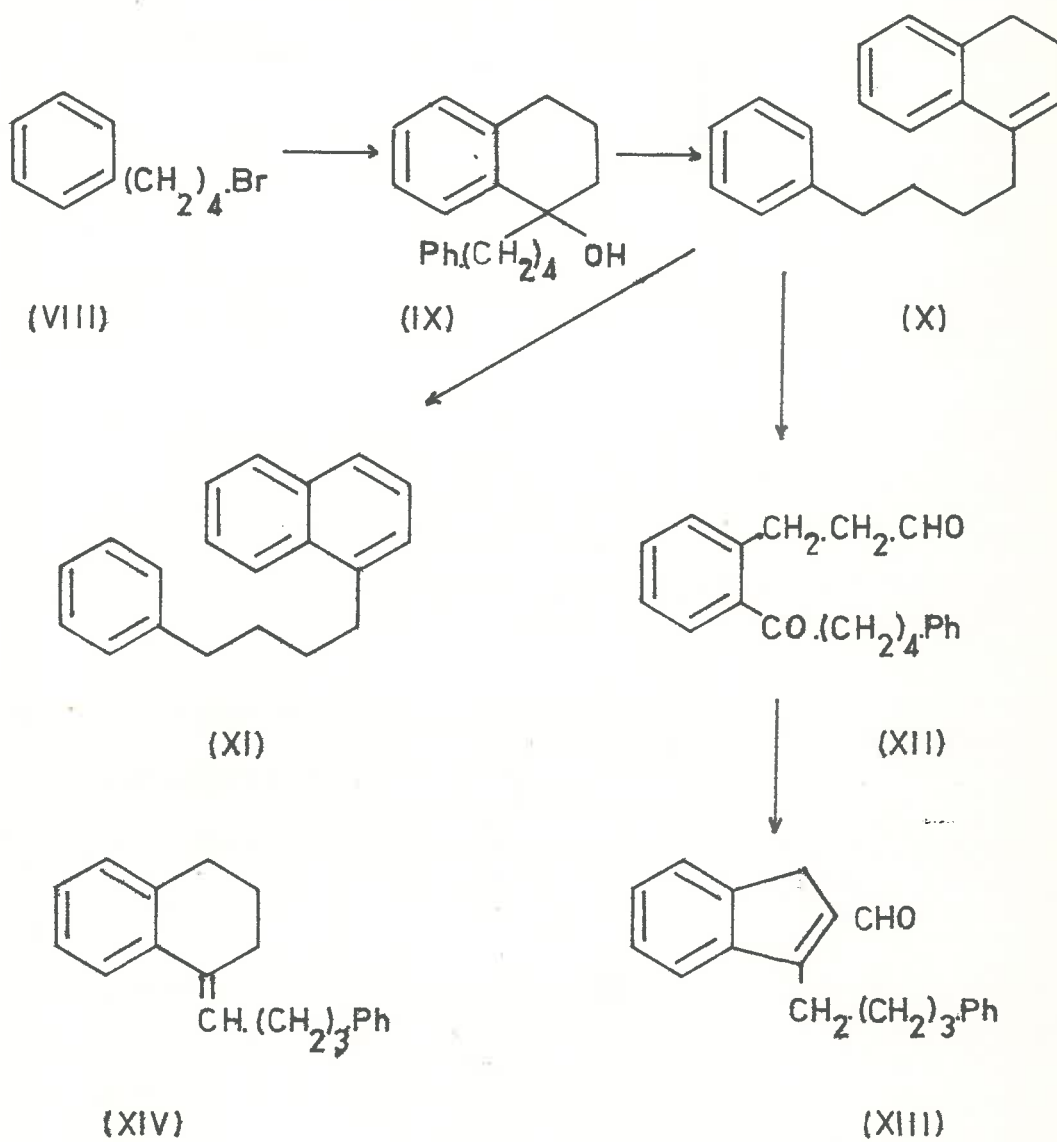

PART II.

The Pyrolysis of a Partially Dehydrogenated
1-4'-Phenylbutyldecalin* and 1-4'-Cyclohexylbutyldecalin.

As the proposed intermediate for the formation of 3:4-benzopyrene in "Schroeter Tar", i.e. 5-4'-phenylbutyl-tetralin, contains a saturated ring adjacent to the benzene ring when the molecule is arranged so that cyclo-dehydrogenation would result in the formation of 3:4-benzopyrene, it was thought desirable to examine compounds with this ring hydrogenated.

A partially dehydrogenated 1-4'-phenylbutyldecalin* and 1-4'-cyclohexylbutyldecalin have therefore been synthesised and some pyrolysis experiments carried out. Pyrolysis of the former at 600° gave, besides some low boiling products, chrysene, and a small amount of 3:4-benzopyrene and perylene. No benzopyrene could be detected in the tar produced by pyrolysis at 360°. However, at 360° with palladium-charcoal as catalyst, pyrolysis gave naphthalene, 1-4'-phenylbutylnaphthalene, 1-phenylphenanthrene and traces of perylene and 3:4-benzopyrene.

* Actually a mixture with 1-4'-phenylbut-1-enyldecalin.

Unchanged starting material was recovered almost entirely from the pyrolysis of 1-4'-cyclohexylbutyldecalin at 360°.

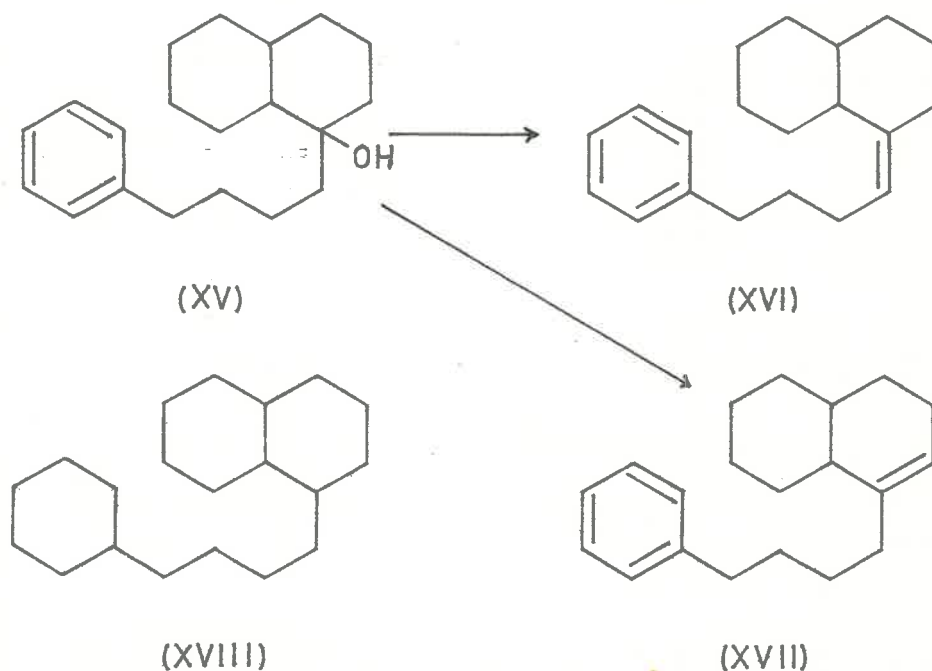

For the synthesis of (XVI) and (XVII) the lithio-derivative of phenylbutylbromide was added to 1-decalone to give the tertiary alcohol (XV). Dehydration gave a mixture of (XVI) and (XVII) (shown by ozonisation). High pressure hydrogenation of 1-4'-phenylbutylnaphthalene with Raney nickel catalyst gave 1-4'-cyclohexylbutyldecalin (XVIII).

PART III.

The Attempted Synthesis of 5-4'-Phenylbutyltetralin.

In view of the proposed formation of 3:4-benzopyrene from 5-4'-phenylbutyltetralin (XXIV) in "Schroeter Tar", it was considered important to try to obtain some of this hydrocarbon itself, for pyrolysis.

Many attempts to synthesis it were carried out. The scheme (XIX - XXIV) was tried exhaustively.

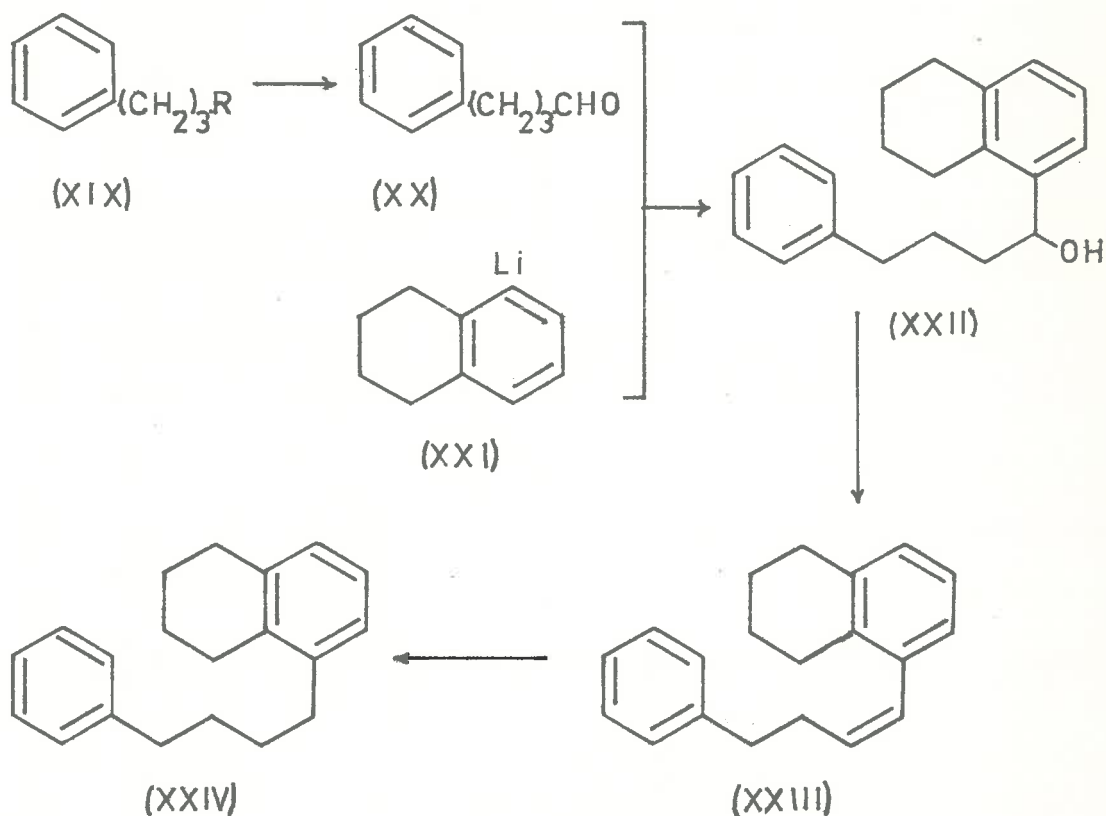

Phenylbutyraldehyde is quite unstable and soon polymerises in air, in contact with alkali, on heating in the presence of oxygen, etc., and is difficult to prepare and handle. Various oxidative and reductive methods were tried for its preparation. Oxidation of (XIX) (where R = CH₂OH) with sodium dichromate, chromium trioxide and pyridine⁵⁶, and dinitrogen tetroxide⁵⁷, all gave poor yields, while dehydrogenation over copper⁵⁸ at 220° gave after purification through the bisulphite compound a 40-50% yield (the best method). Where R = CH₂ Br nitration with silver nitrite⁵⁹ followed by reduction of the sodium salt gave very little aldehyde. Where R = COCl Rosenmund reduction with or without poisoning, and also reduction with lithium-tri-t-butoxyaluminium hydride⁶⁰ gave poor yields.

Analyses of the compounds (XXII), (XXIII) and (XXIV) were very poor. Dehydration of the secondary alcohol did not remove all the oxygen. A mixture of the required compound with polymers formed by the action of excess lithium on the aldehyde seems probable, and the method was eventually abandoned.

The scheme (XXV - XXVII) was also tried. However, satisfactory yields of the starting material (XXV) could not be obtained. Hence this approach was also abandoned.

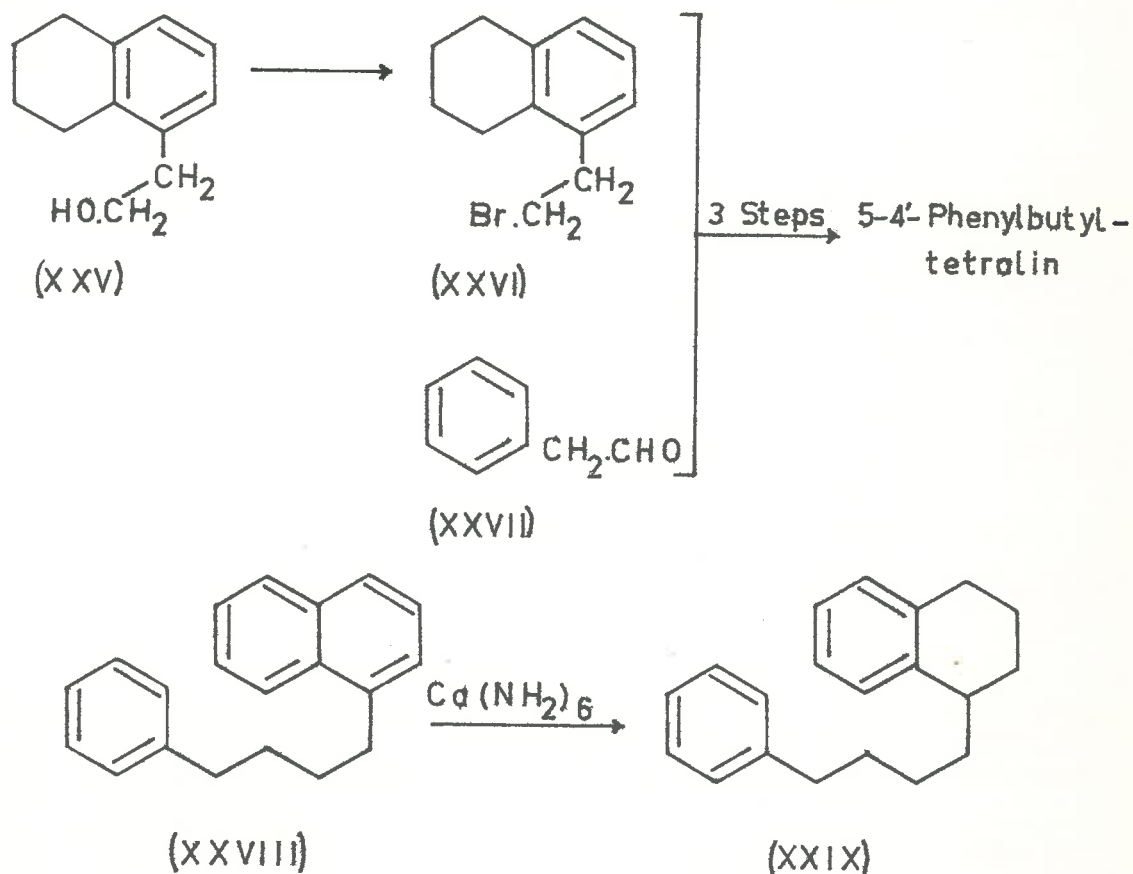

Boer and Duinker⁶¹ have described the selective reduction of alkylnaphthalenes to alkyltetralins with calcium hexamine to give 3% reduction in the substituted ring and 97% in the non-substituted. However, reduction of 1-4'-phenylbutylnaphthalene (XXVIII) in this way gave 1-4'-phenylbutyltetralin (XXIX).

Finally attempts were made to effect the condensation of the two parts of the molecule using 5-cyanotetralin (XXXI) and phenylpropylbromide (XXX) via the Grignard complex or via the lithium alkyl to give the ketone (XXXII). However, both gave unidentifiable products. Similarly condensation of 5-bromotetralin (XXXIV) and phenylbutyryl chloride (XXXIII) via the Grignard and cadmium complexes also gave the ketone (XXXII).

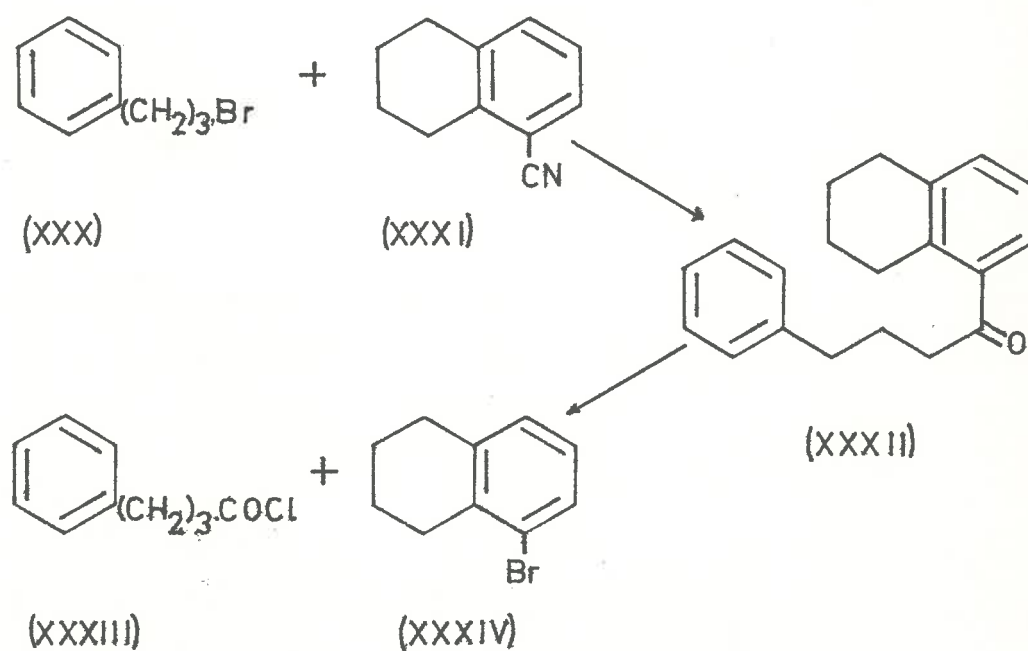

In this case a small amount of ketonic material was obtained, which however, showed four bands in the carbonyl region in the infrared, indicating a mixture.

As 3:4-benzopyrene is formed in "Schroeter Tar" only after distillation (see Chapter II) it seems possible, in this case, that some cyclodehydrogenation has occurred during distillation of the product to give e.g. compounds (XXXV) and (XXXVI).

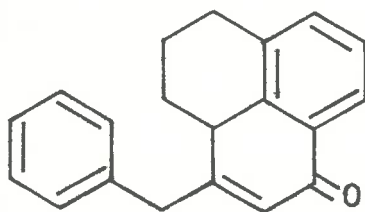

(XXXV)

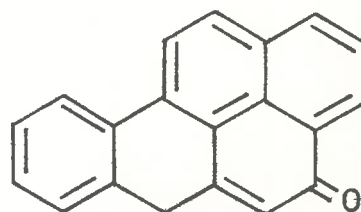

(XXXVI)

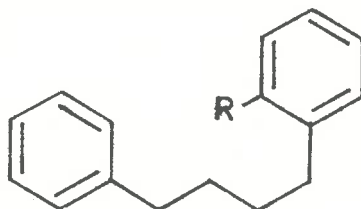

(XXXVII)

Another possible method of synthesis involving an ortho-substituted diphenylbutane intermediate (XXXVII) was considered. However, it did not seem promising, and was not attempted.

EXPERIMENTAL.

4-Phenylbutan-1-ol.- Ethyl 4-phenylbutyrate (100 g.) obtained from the reduction with hydrogen and copper chromite of ethyl 3-benzoylpropionate⁶², in ether (100 c.c.) was added dropwise to a suspension of lithium aluminium hydride (30 g.) in ether (500 c.c.). The reaction mixture was refluxed for 1 hr. and then carefully decomposed with water and dilute sulphuric acid. The ethereal extract was dried, evaporated, and the alcohol distilled as a colourless oil, (73 g., 96%), b.p. 124-127°/9 mm. (Lit.⁶³ 140°/17 mm.) η_D^{24} 1.5188. The phenylurethane had m.p. 51-52° (Lit.⁶⁴ 51-52°).

4-Phenylbutyl Bromide.- Method (1) 4-Phenylbutan-1-ol (50 g.) was added dropwise to phosphorus pentabromide (120 g.). After standing at room temperature for ½ hr. the reaction mixture was heated on a water-bath for 1 hr. It was poured onto ice, the oil washed with water, sodium bicarbonate solution, and water, and then finally dried over anhydrous calcium sulphate. Removal of the ether and distillation of the residue gave 4-phenylbutyl bromide (51.5 g., 76%), b.p. 132°/12 mm., (Lit.⁶³ 132°/12 mm.), $\frac{19}{D}$ 1.5408.

Method (ii) The alcohol (50 g.) was added slowly, with stirring to a slight excess of phosphorus tribromide (120 g.) contained in a three-necked flask fitted with a mercury-sealed stirrer, dropping funnel, and drying tube. After the addition was complete, the reaction mixture was heated, with stirring, on the water-bath for 1-2 hr. The crude material was worked up as in method (i) to give the bromide (49 g., 72%).

1-Hydroxy-1-4'-phenylbutyltetralin.- Method (i)

1-Tetralone (21 g.) was added dropwise to the Grignard reagent prepared from 4-phenylbutyl bromide (30 g.) and magnesium (4 g.) in ether (45 c.c.). After refluxing for ½ hr. the complex was decomposed by pouring onto ice (70 g.) and 10% hydrochloric acid (100 c.c.). The ethereal solution was thoroughly washed with water, dried, and the ether removed. Distillation of the residue gave three fractions; (a) b.p. 80-100°/30 mm. (10 g.) η_D^{25} 1.5040; (b) b.p. 120-140°/30 mm. (12 g.); and (c) b.p. 170-172°/0.1 mm. (15 g., 37%). Fraction (a) was carefully fractionated in a Griffin and Tatlock semi-micro distillation apparatus. Infrared spectroscopy and the refractive index of the constant boiling main part of the distillate showed this to be n-butylbenzene.

Fraction (b) was mainly 1-tetralone, while fraction (c) on redistillation gave 1-hydroxy-1-4'-phenylbutyltetralin, b.p. 170-172°/0.1 mm., n_D^{17} 1.5760, (Found: O, 5.5; C₂₀H₂₄O requires O, 5.7%).

Method (11) 20 Drops of a solution of the bromide (35 g.) in ether (50 c.c.), was added to a nitrogen flushed flask containing lithium wire (3.5 g.) in ether (75 c.c.). When a slight milkiness of the solution developed, showing the reaction had commenced, the reaction mixture was cooled to -10° in a dry-ice/ethanol bath. The remainder of the bromide solution was added, with stirring, over ½ hr. maintaining the internal temperature at -10°. The stirring was continued for a further 2 hr. allowing the temperature to rise to 10° over this period. (c.f. butyllithium⁶⁵). To this solution was added dropwise tetralone (24 g.) in ether (25 c.c.) maintaining the temperature between 10-20°. After refluxing for ½ hr. and filtering the product through glass wool, it was worked up as in method (1). Distillation gave 1-hydroxy-1-4'-phenylbutyltetralin (27 g., 57%), together with the same fore-runs as in the first method.

Attempts to make a p-nitrobenzoate, 3:5-dinitrobenzoate, and a p-bromophenacyl ester failed.

3:4-Dihydro-1-4'-phenylbutylnaphthalene.- The above alcohol (8 g.) in ethanol (100 c.c.) and sulphuric acid (1 c.c.) was refluxed for 1 hr. and the reaction mixture poured into a large volume of cold water. The oil which separated, was removed, dried, and distilled to give an almost quantitative yield of 3:4-dihydro-1-4'-phenylbutylnaphthalene, b.p. 174-176°/0.1 mm., η_D^{23} 1.5809, (Found: C, 91.6; H, 8.6. $C_{20}H_{22}$ requires C, 91.6; H, 8.4%). The oil exhibited a blue-violet fluorescence in ultraviolet light.

Determination of the Position of the Double Bond.- Ozonisation of the dehydrated alcohol (2 g.) in ethyl acetate (15 c.c.) and after the addition of ethanol (20 c.c.), decomposition of the ozonide with 10% palladium/charcoal and hydrogen gave a viscous residue on removal of the solvent. Treatment with sodium bicarbonate removed a small amount of acid formed. Infrared absorption spectroscopy of the unextracted position showed two bands in the carbonyl region (5.80 and 5.93), one corresponding to a aldehydic and the other to a ketonic group. The 2:4-dinitrophenylhydrazone, considered as being 3-4'-phenylbutylindene-2-aldehyde dinitrophenylhydrazone crystallised from chloroform as fine red prisms, m.p. 210-211° (Found: C, 68.4; H, 5.3; N, 12.4; O, 14.2;

$C_{26}H_{23}N_4O_4$ requires C, 68.6; H, 5.1; N, 12.3; O, 14.05%.

Infrared absorption spectroscopy showed no carbonyl groups present in the 2:4-dinitrophenylhydrazone.

However, on regenerating some of the carbonyl compound by heating the derivative with pyruvic acid at 100° for 7-8 hr.⁶⁶ only the aldehydic band (5.84μ) was shown.

1-4'-Phenylbutylnaphthalene.- The above hydrocarbon (14 g.), 10% palladium/charcoal (4.25 g.) and p-cymene (70 c.c.) were heated under reflux in an atmosphere of nitrogen for 5 hr. The initial heating was carefully controlled as the early part of the reaction was very vigorous due to the elimination of hydrogen. The liquid was filtered off, and the catalyst thoroughly washed with boiling benzene. The solvents were removed by distillation, and the dehydrogenated product distilled under vacuum. Redistillation gave 1-4'-phenylbutylnaphthalene (12.5 g.), as a viscous oil, b.p. $164-6^{\circ}/0.3$ mm., and $345-350^{\circ}/760$ mm., η_D^{22} 1.5990 (Found: C, 92.0; H, 8.0. $C_{20}H_{20}$ requires C, 92.3; H, 7.7%). The absorption spectrum in cyclohexane showed maxima ($\log \epsilon$ in parenthesis) at: 226 (4.75); 240 (3.32) infl.; 264 (3.56) infl.; 273 (3.78); 283 (3.81); and 290 (3.52). (See Fig. 3-1). The phenylbutylnaphthalene exhibited a pale blue

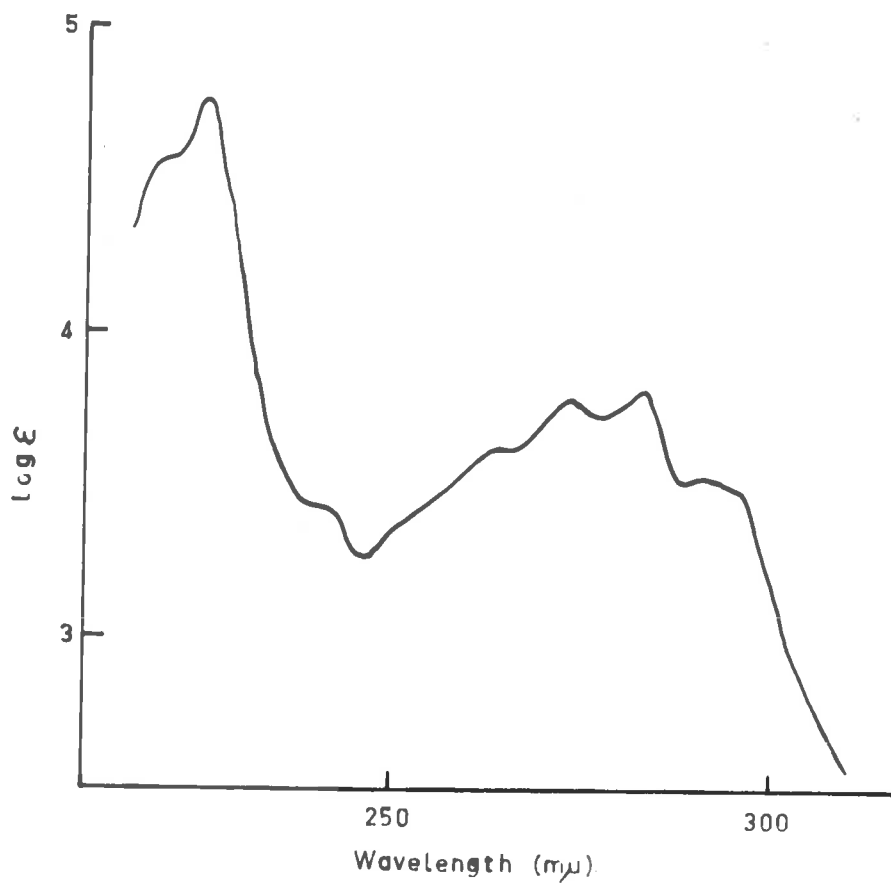

Fig. 3*1. 1-4'-Phenylbutylnaphthalene.

fluorescence in ultraviolet light.

Pyrolysis of 1-4'-Phenylbutylnaphthalene.--

(i) At 360°. Phenylbutylnaphthalene (2 g.) was refluxed for 20 hr. during which the colour of the liquid changed from pale yellow to reddish-green. The product which exhibited a deep green-yellow fluorescence was chromatographed on activated alumina (20 x 2½ cm.). Elution with hexane brought through unchanged phenylbutylnaphthalene (1.5 g.). Further elution with benzene-hexane (1:1) yielded fractions containing a very small amount of yellow crystalline material. Fluorescence spectra taken of these fractions showed five bands identical with those of an authentic specimen of 3:4-benzopyrene and four corresponding to those of perylene (Plate 3.1a). The fractions combined were extracted with cold concentrated sulphuric acid²⁶ and after further chromatography, gave a very impure sample of 3:4-benzopyrene (less than 1 mg.). Its absorption spectrum showed maxima at 365, 384, and 405 mμ only (Fig. 3.3). Literature values in this region are 364, 384, and 404 mμ.

(ii) At 360° with palladium-charcoal. Phenylbutylnaphthalene (2 g.) and 5% palladium-charcoal (0.5 g.) were heated under reflux for 5 hr. After 2 hr. the

temperature of the refluxing vapour had decreased to 200° apparently due to the presence of low boiling products formed by cracking. However, after a further 2 hr. the temperature had returned to 360°. The reaction mixture was filtered from the catalyst, which was washed well with boiling benzene. After removal of the solvent, chromatography on activated alumina (20 x 2½ cm.) was carried out in hexane. Elution with hexane gave fractions which on removal of the solvent gave a white solid (1.25 g.). This was identified as 1-phenylphenanthrene, prisms, m.p. 78-79° (lit.⁶⁷ 78-79°) (Found: C, 94.6; H, 5.75. Calc. for C₂₀H₁₄: C, 94.5; H, 5.5%). The picrate had m.p. 117-118° (lit.⁶⁷ 117-118°). (Found: N, 8.8. Calc. for C₂₀H₁₄C₆H₃N₃O₇: N, 8.7%). The ultraviolet absorption curve (Fig. 3-2) is of the type expected. Further elution of the column with benzene-hexane (1:2) gave seven fractions, each of 70 c.c., two of which showed faint 3:4-benzopyrene bands in its fluorescence spectrum (Plate 3-1b). However, after cold sulphuric acid extraction, the fractions did not give any maxima of 3:4-benzopyrene on submission to ultraviolet absorption spectroscopy. Quite strong fluorescence bands corresponding to those of perylene suggested that

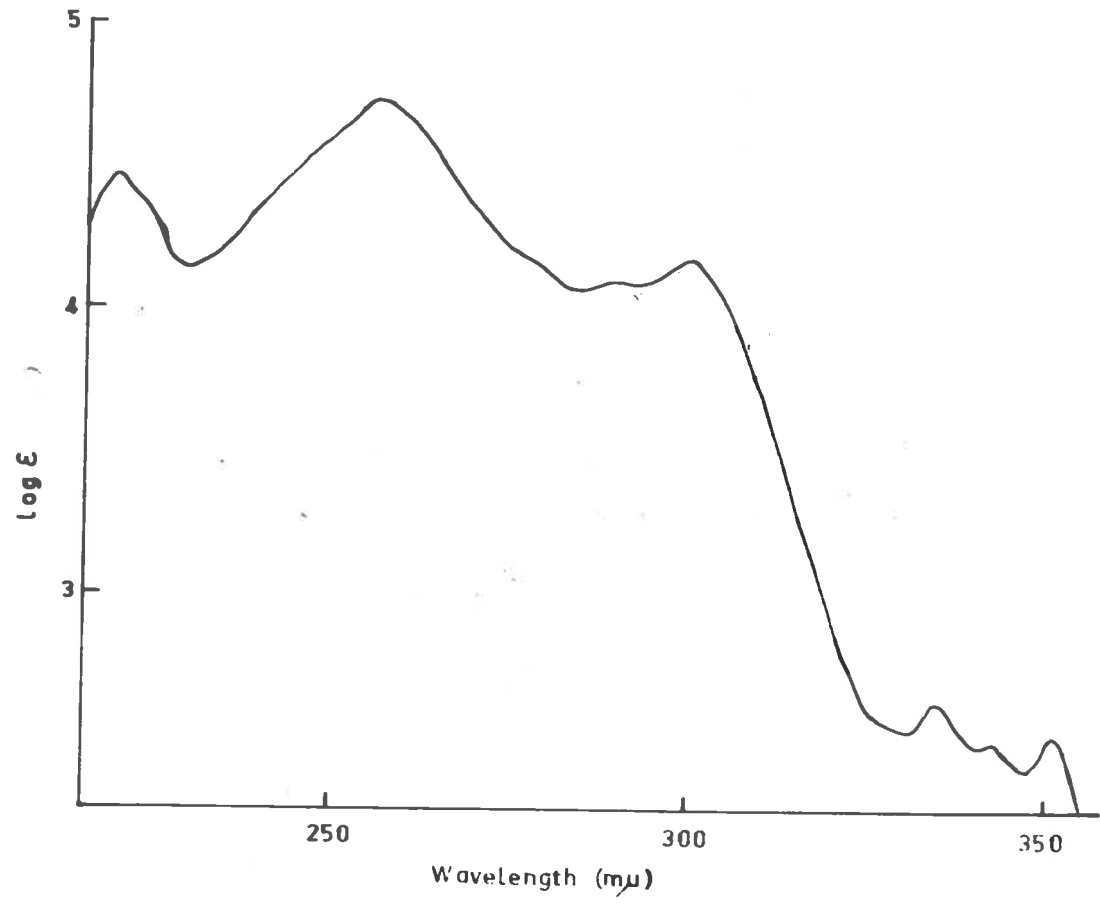

Fig. 3·2. 1-Phenylphenanthrene.

a small amount of this was present (Plate 3-1b).

(iii) At 360° with palladium-asbestos. Method (ii) was repeated using 5% palladium-asbestos catalyst. After removal of the low boiling products (0.5 c.c.) by distillation, the residue was chromatographed on alumina. Elution with hexane brought through mainly recovered starting material. However, the later fractions contained, on removal of the solvent, small amounts of a white solid, which had fluorescence spectral bands (in benzene) at 415, 440, and 475 μ , and had a chrysene type ultraviolet absorption spectrum. Elution with benzene-hexane (1:2) gave an impure mixture of 3:4-benzopyrene and perylene identified by their ultraviolet absorption maxima at 364, 384, and 406 and 434 μ (Fig. 3-4) respectively, and by their fluorescence spectra. About 1 mg. of each was present. (Estimated from the absorption spectrum).

(iv) At 360° with activated charcoal. Repetition of method (ii) using only activated charcoal as catalyst gave naphthalene (100 mg.), identified by m.p. and mixed m.p. Chromatography of the residue and elution with hexane gave on removal of the solvent 1-phenylphenanthrene

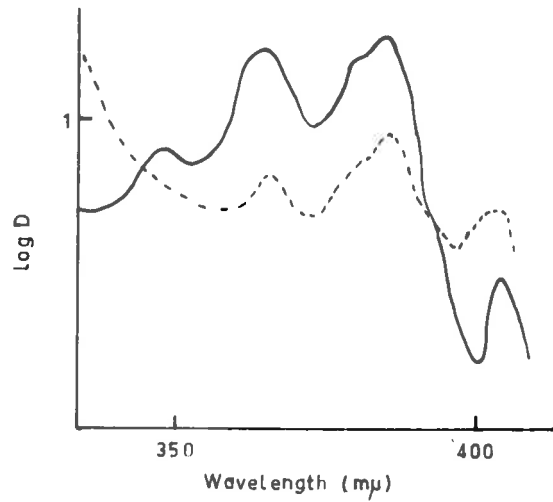

Fig. 3.3. 3:4-Benzopyrene from pyrolysis of 1-4'-phenylbutylnaphthalene at 360° (---). (Authentic: —).

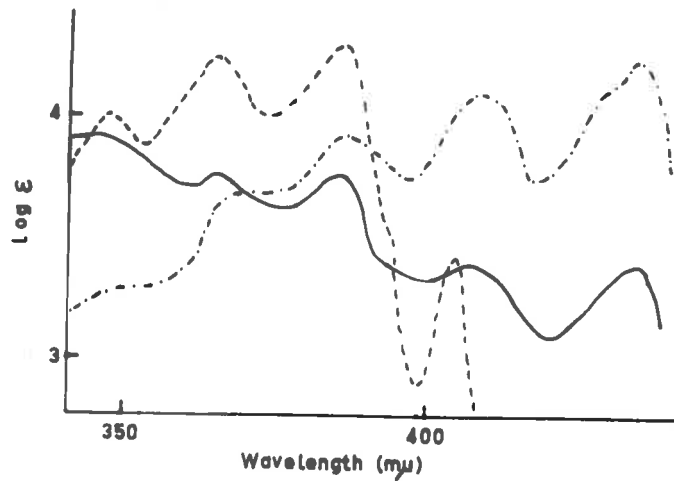

Fig. 3.4. 3:4-Benzopyrene from pyrolysis at 360° with palladium/asbestos (—). Authentic 3:4-benzopyrene (---), and perylene (— · — ·).

(150 mg.), m.p. 78-79°, mixed m.p. with sample obtained from (ii), 78-79°. Elution with benzene-hexane (1:2) brought through an intensely blue band which on removal of the solvent, yielded perylene (6 mg.), m.p. 265° (lit.⁴⁶ 265). This was confirmed by its fluorescence spectrum (Plate 3·1c).

(v) At 600°. The phenylbutylnaphthalene (5 g.) was vapourised at the rate of 1 drop every 15 secs. and passed with nitrogen (1 c.c./sec.) through a silica tube (36 x 1 in.) packed with porcelain chips ($\frac{3}{8}$ - $\frac{1}{4}$ in.) heated to 600° in a special electrically heated furnace (see Chapter I). The resulting red non-viscous tar, which contained some crystalline material, was distilled to remove the low boiling products; to give fractions (a) and (b). Fraction (a) (1.25 g.), b.p. 110-120°, was shown by infrared spectroscopy and refractive index, to be mainly toluene. The colourless solid, which crystallised from fraction (b), b.p. 90-120°/28 mm., was sublimed from the rest of the fraction, and on recrystallisation from ethanol, gave naphthalene (0.1 g.), m.p. 80°, which was not depressed on admixture with an authentic sample. After redistillation, the yellow liquid, forming the remainder of the fraction, was

identified by its infrared and ultraviolet spectra as 1-methylnaphthalene (1.3 g.). The picrate had m.p. 140-142^o, and mixed m.p. 140-142^o.

The residue (1.5 g.) after distillation, was dissolved in a minimal amount of a mixture of benzene and hexane and chromatographed on a column of activated alumina (20 x 2½ cm.). Elution with hexane brought down a blue fluorescent band in five fractions (70 c.c. each). Further elution with benzene-hexane (1:1) gave two more fractions from an orange fluorescent band, and then elution with pure benzene eluted a yellow fluorescent band in two more fractions. Examination of the fluorescence spectra of the nine fractions showed diffuse bands in the 3:4-benzopyrene region (400-450 mμ) in fractions 3 to 6. Rechromatography of these fractions (3-6) combined, followed by extraction with cold sulphuric acid⁴⁹, of the fractions shown by their fluorescence spectra to contain probably 3:4-benzopyrene, and further chromatography of this extract gave a pale yellow solution on elution with benzene-hexane (1:2). This solution fluoresced blue, both in visible and ultraviolet light. Examination of the fluorescence spectrum showed three bands at high wavelength (445, 475 and 502 mμ) as well as

those of 3:4-benzopyrene (Plate 3·1d). A reasonable separation of the 3:4-benzopyrene from the contaminant was effected by chromatography on alumina (30 x 5 cm.) and elution, under vacuum, with hexane. Elution with 6-8 litres of hexane brought through a pale violet fluorescent first fraction, which was followed, on elution with 5 litres more of hexane, by a blue fluorescent band. Finally, the remainder of the fluorescent (violet) material on the column came through with another 4 litres of hexane. On removal of the solvent, and after yet another chromatographic run on each of the latter two fractions, small amounts of crystalline material were isolated. The first fraction showed four maxima of 3:4-benzopyrene and three maxima of perylene on ultraviolet spectroscopy. (Fig. 3·5). (The maxima of perylene were at 386, 408, 434 μ). The estimated amount of perylene present from the absorption curve was 3 mg. Confirmation of this was given by comparison of the fluorescence spectrum with that of a sample of authentic perylene (Plate 3·1e). The ultraviolet absorption spectrum of the second yellow crystalline fraction (10 mg.) was identical with that recorded for 3:4-benzopyrene^{46,47}. (Fig. 3·6). It had m.p. 170-172^o, mixed

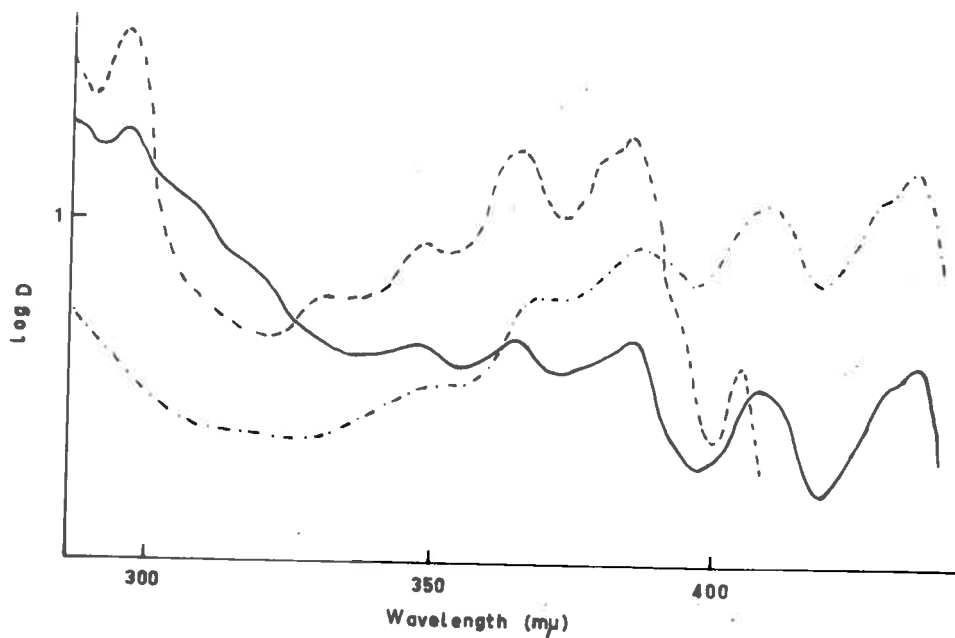

Fig. 3.2. 3:4-Benzopyrene and perylene from pyrolysis at 600° (—). Authentic 3:4-benzopyrene (---) and perylene (---).

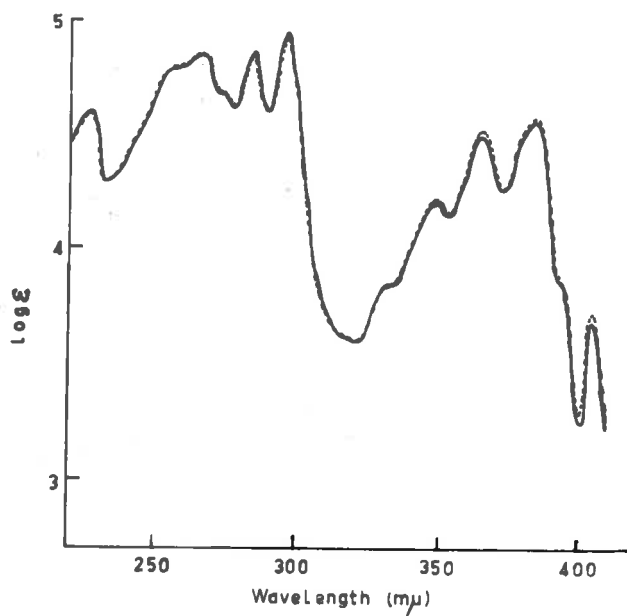

Fig. 3.6. 3:4-Benzopyrene from pyrolysis at 600° (—). Authentic (---).

m.p. 171-174^o, (lit. 176-177^{o46}). The picrate which could not be obtained in a pure state, had m.p. greater than 180^o (lit. 198^{o46}).

Fractions 1 and 2 of the original chromatogram were combined and rechromatographed with hexane as elutant. The first fractions gave, on removal of the solvent, a yellow liquid from which crystallised a white solid. This was washed free of oily material with cold ethanol, and recrystallisation from ethanol gave white prisms of 1:1'-dinaphthyl (20 mg.), m.p. 143-146^o, mixed m.p. 145-147^o. The ultraviolet absorption spectrum had maxima at (authentic in parenthesis) 221 (220), 283 (283), and 293 (294 ~~mμ~~)⁶⁸. Further elution of the chromatogram with benzene-hexane (1:2) gave a pale blue fluorescent solution, which on fluorescence spectrophotographic examination, showed very faint diffuse bands similar to those of pyrene. The ultraviolet absorption spectrum showed maxima at (authentic values in parenthesis), 240 (241), 259 (261), 272 (272), 304 (305), 319 (318), 335 (334 ~~mμ~~) corresponding to those of pyrene⁴⁶. The estimated amount of pyrene was less than 10 mg. Examination of the fractions 7-9 of the original chromatogram gave no further identifiable products.

(vi) At 700°. The phenylbutyl naphthalene was pyrolysed in the same manner as at 600°, and the resulting tar chromatographed on alumina. Elution with benzene-hexane (1:3), benzene-hexane (1:1), and finally with pure benzene gave 12, 8, and 10 fractions (each of 70 c.c.) respectively. Fluorescence spectral examination of these fractions showed no distinctive bands in fractions 1-13, however, fractions 14-24 showed bands in the 3:4-benzopyrene region. The remaining fractions showed bands of higher wavelength.

Removal of the solvent from fractions 1 and 2 gave a yellow solid, which after two recrystallisations from ethanol, was identified as naphthalene (2 g.). It had m.p. 80°, not depressed by admixture with an authentic sample. Cold sulphuric acid extraction of fractions 14-24, followed by chromatography on alumina of the main blue-violet band, gave a yellow solid (5 g.), whose ultraviolet absorption maxima corresponded with those of 3:4-benzopyrene (Fig. 3.7). However, this could not be obtained sufficiently pure to take an accurate melting point. Small amounts of perylene were probably present. This was shown by faint characteristic bands in fluorescence spectral photographs.

Fractions 25-30 were combined, and rechromatographed

on alumina. Elution with benzene-hexane (1:2) eluted blue-violet, blue, and finally yellow bands from the column. The fluorescence spectra showed that fractions 1-3 contained small amounts of 3:4-benzopyrene, while fractions 4-6 showed bands at 412, 438, and 465 μ , (Plate 3.1f), and the remaining fractions showed very intense bands at 470, 500, and 540 μ (plate 3.1g). Ultraviolet absorption spectroscopy of the second fraction still showed six 3:4-benzopyrene maxima, together with a further six (222, 242, 250, 274 (infl.) 310 and 326 μ) maxima of an unidentified compound or compounds (Fig. 3.8). The third fraction was too impure for any identification of the compound to be made.

(vii) At 500°. The phenylbutylnaphthalene (5 g.) was passed through an empty pyrex tube, heated to 500° in the special electrically heated furnace, as in the previous runs at 600° and 700°. Chromatography on alumina (30 x 4 cm.) of the resulting tar, and elution with cyclohexane, gave mainly starting material (refractive index and ultraviolet spectra). Fluorescence spectra of the subsequent fractions, eluted with benzene-cyclohexane (1:2), failed to indicate the presence of any 3:4-benzopyrene.

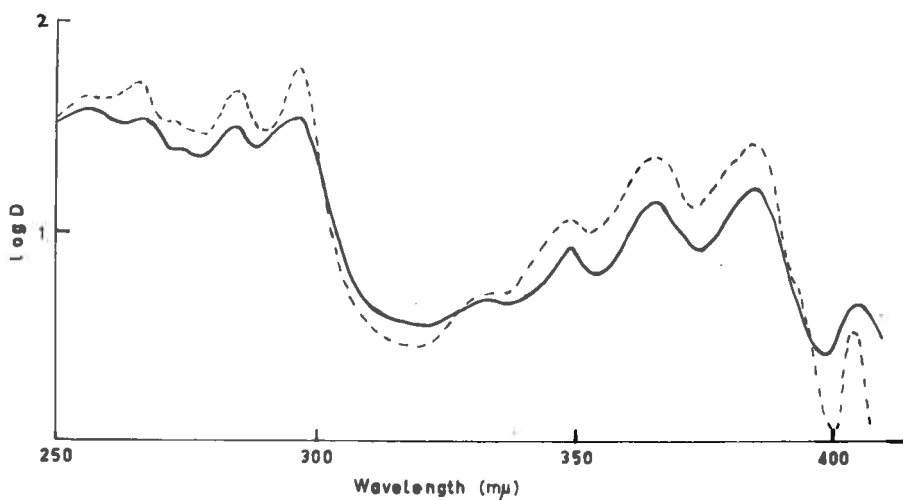

Fig. 3-7. 3:4-Benzopyrene from pyrolysis at 700° (—).
Authentic (- - -).

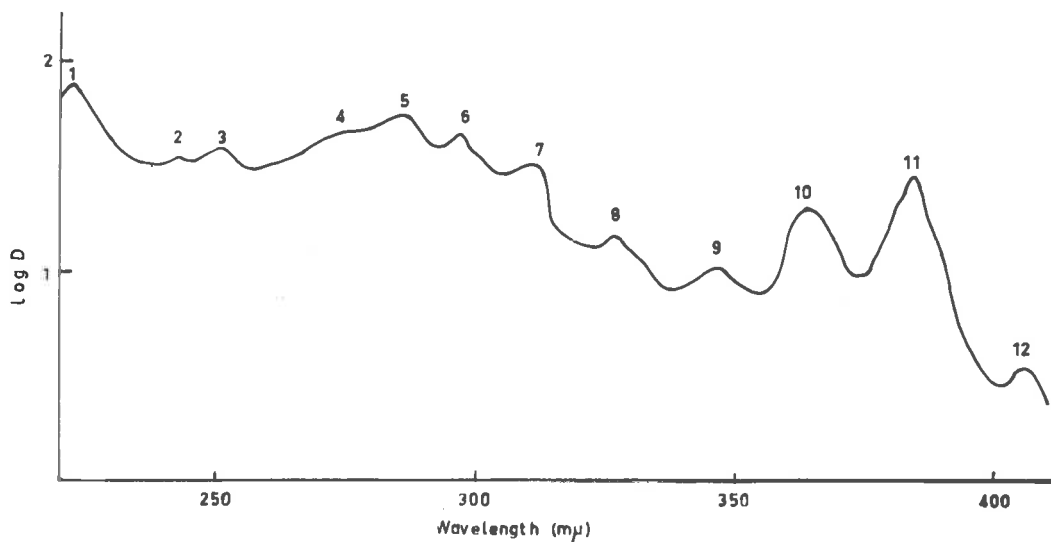

Fig. 3-8. 3:4-Benzopyrene from pyrolysis at 700° (peaks 5, 6, 9, 10, 11, and 12). Unknown (peaks 1, 2, 3, 4, 7, 8).

1-Hydroxy-1-4'-phenylbutyldecalin.- 4-Phenylbutyl bromide (20 g.) in ether (30 c.c.) was added to lithium wire (2 g.) in ether (50 c.c.) by the method described for 1-hydroxy-1-4'-phenylbutyl-naphthalene. 1-Decalone⁶⁹ (14 g.) in ether (20 c.c.) was added dropwise to the resulting lithio compound. After working up as usual, distillation gave three fractions: (a) b.p. 68-104°/12 mm. (3 g.); (b) b.p. 104-130°/12 mm. (2 g.) and (c) b.p. 179-185°/0.7 mm. (17 g., 63.5%). Redistillation of fraction (c) gave 1-hydroxy-1-4'-phenylbutyldecalin as a viscous colourless oil, b.p. 186-188°/1 mm.

η_{D}^{16} 1.5383 (Found: C, 84.2; H, 10.5; O, 5.8. $\text{C}_{20}\text{H}_{30}\text{O}$ requires C, 83.9; H, 10.5; O, 5.6%). Fraction (a) on redistillation was identified as largely n-butylbenzene while (b) was mainly recovered starting material.

Dehydration of 1-hydroxy-1-4'-phenylbutyldecalin.-

The above alcohol (17 g.) was dehydrated by refluxing in ethanol (75 c.c.) and concentrated sulphuric acid (3 c.c.) for 1½ hr. The reaction mixture was poured into water (800 c.c.), extracted twice with ether, dried, the solvent removed, and distilled. Redistillation gave a colourless non-viscous oil (14 g., 88%) b.p. 168-170°/0.8 mm.,

η_{D}^{12} 1.5400 (Found: C, 89.3; H, 10.5. $\text{C}_{20}\text{H}_{28}$ requires

C, 89.6; H, 10.4%); $\lambda_{\text{max.}}$ (log ϵ) in ethanol 222 infl. (3.25), 227 (3.55), 248 infl. (2.32), 252 (2.38), 258 infl. (2.30, 261 (2.38), 269 (2.38).

Position of unsaturation.- The above unsaturated compound was ozonised and worked up as for the corresponding dihydrophenylbutylnaphthalene. The resulting neutral fraction gave a 2:4-dinitrophenylhydrazone of indefinite m.p. The mixture could not be separated by chromatography on a bentonite-Kieselguhr column.

Pyrolysis of the above mixture.- (1) At 360° with palladium-charcoal. The above mixture of unsaturated compounds (2 g.) was refluxed with 10% palladium-charcoal for 5 hr. in an atmosphere of nitrogen. During this time, the reaction mixture developed a green-yellow fluorescence. The product was filtered from the catalyst, which was washed well with boiling benzene. On removal of the solvent the residue was chromatographed on alumina (20 x 3 cm.). Elution with hexane (4 fractions of 60 c.c.) brought through a violet fluorescent band. The first of these fractions contained most of the product (1.5 g.). Distillation of this fraction gave a trace of naphthalene m.p. 80°, and an oil b.p. 182-186°/0.5 mm.

which was identified by its absorption spectrum (maxima at 226, 262, 272, 283, and 294 μ) and refractive index (n_D^{18} 1.5973) as 1-4'-phenylbutylnaphthalene.

The residue remaining after distillation (100 mg.), partially solidified. It was identified by absorption and fluorescence spectroscopy, as essentially 1-phenylphenanthrene (absorption maxima at 258, 290, 302, 334, 342 and 350 μ).

Further elution of the column with benzene-hexane (1:2) brought through a blue band. Removal of the solvent, and examination of the very small amount of residue by fluorescence spectroscopy, showed faint bands of perylene and 3:4-benzopyrene. However, the presence of impurities was shown by the diffuse nature of the bands and the presence of other bands (Plate 3-1h). This was supported by absorption spectroscopy which showed maxima at 364, and 384 μ identified with 3:4-benzopyrene, and at 407 and 434 μ identified with perylene. The estimated amount of these present, derived from the absorption curve, was less than 1 mg.

(11) At 600°. The mixture (5 g.) was passed with nitrogen (1 c.c./sec.), at the rate of 1 drop every 15 secs., through a silica tube packed with porcelain chips

($\frac{3}{8}$ - $\frac{1}{4}$ in.) heated at 600° . Distillation of the non-viscous reddish tar obtained, gave several low boiling fractions (total, 2.3 g.), up to b.p. $115^{\circ}/15$ mm. and a residue (1 g.). Gas-liquid chromatography of the low boiling fractions gave retention times corresponding to benzene, toluene, ethylbenzene, styrene, butylbenzene (?), naphthalene and 1- and 2-methylnaphthalene.

The residue was chromatographed on alumina (25 x 3 cm.). Elution with hexane brought through chrysene m.p. $250-252^{\circ}$ (lit.⁴⁶ $255-256$ corr.). Its absorption spectrum was essentially in agreement with the literature⁴⁶. (Fig. 3-9). The trinitrobenzene complex had m.p. $192-194^{\circ}$ (lit.⁷⁰ $192-194$). Further elution of the column with benzene-hexane (1:2) gave some fractions which had diffuse 3:4-benzopyrene type fluorescence spectra. Treatment of the residues after removal of the solvent with cold sulphuric acid⁴⁹ followed by further chromatography of the extract gave 3:4-benzopyrene, identified by its ultraviolet absorption maxima at 254, 266, 284, 296, 331, 347, 364, 384 and 404 (Fig. 3-10), and a very weak band of perylene at 434 m μ .

(iii) At 360° . No benzopyrene could be detected in the product after refluxing the mixture (2 g.) under

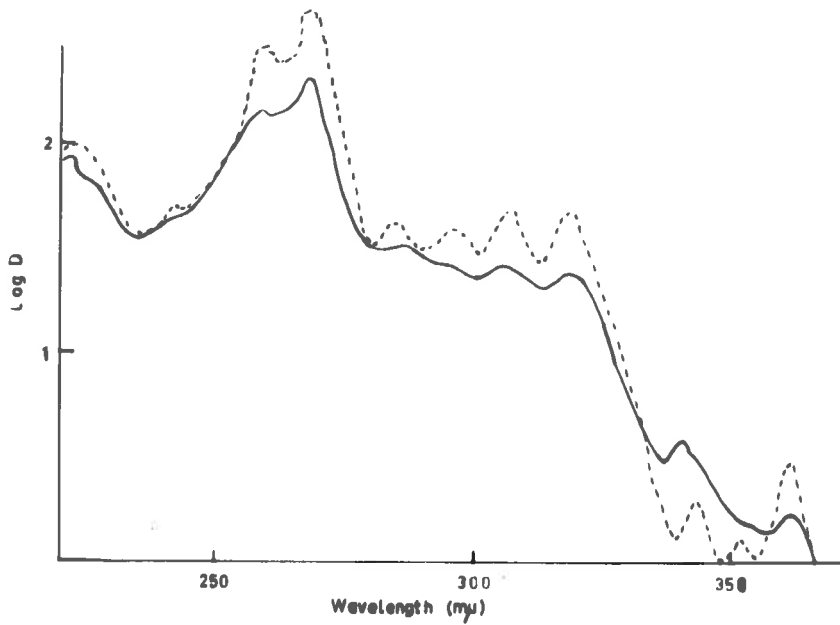

Fig. 3.9. Chrysene (This work: —). (Authentic: - - -).

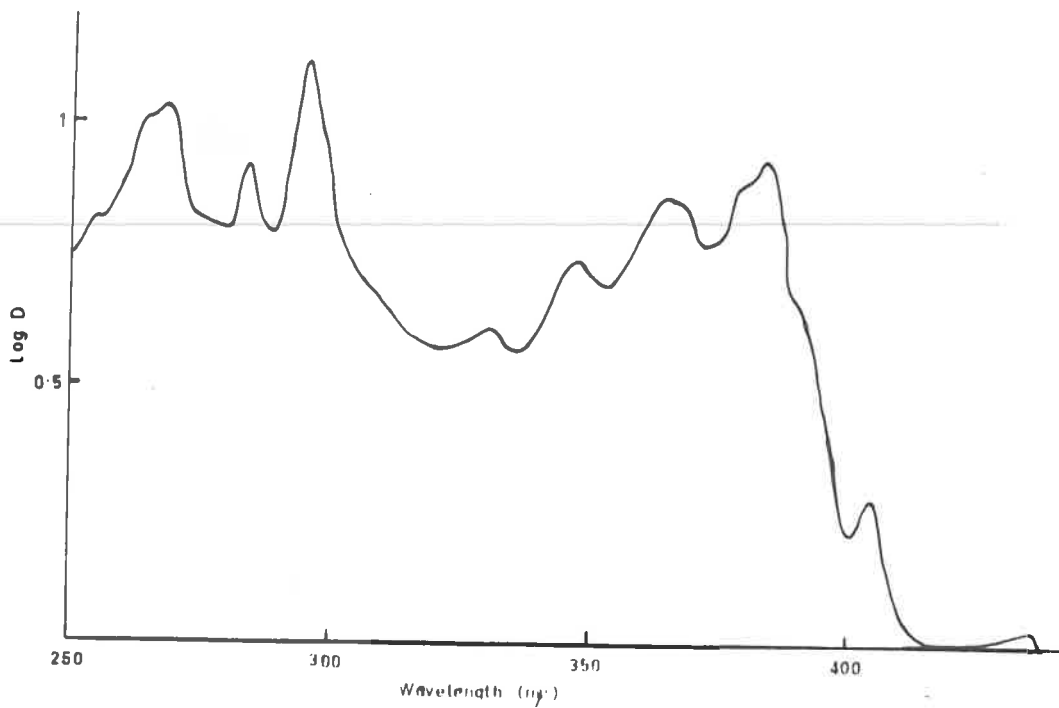

Fig. 3.10. 3:4-Benzopyrene from pyrolysis & mixture of partially dehydrogenated 1-4'-phenylbutylacalins. (Impure).

nitrogen for 20 hr.

1-4'-Cyclohexylbutyldecalin.- 1-4'-Phenylbutyl-tetralin (10 g.) in a mixture of tetralin (20 c.c.) and cyclohexane (200 c.c.) was hydrogenated in a bomb (1.5 l.), using W7 Raney-nickel (2.5 g.) as a catalyst. An initial hydrogen pressure of 110 atmospheres was used and the temperature raised to 200° in 1½ hr. This was maintained for a further 15 min., and the bomb allowed to cool. The reaction mixture was filtered from the catalyst, the catalyst washed with boiling ethanol, and the combined solutions distilled in vacuo to remove the solvents. Distillation of the residue gave 1-4'-cyclohexylbutyl-decalin (8 g., 78%) as a colourless oil b.p. 142-144°/0.05 mm., η_D^{12} 1.4983 (Found: C, 87.1; H, 12.7. C₂₀H₂₆ requires C, 87.0; H, 13.0%). The pure material had a pale blue fluorescence in ultraviolet light.

Pyrolysis of 1-4'-Cyclohexylbutyldecalin.- The cyclohexylbutyldecalin (1 g.) was refluxed for 7 hr. However, no identifiable material was recovered other than the starting material, which constituted almost the entire product.

Attempted Synthesis of 5-4'-Phenylbutyltetralin.-

Method (i) To the 5-lithiotetralin, in an atmosphere of nitrogen, prepared from 5-iodotetralin (10 g.) by the method for the preparation of phenyllithium⁶⁵, phenylbutyraldehyde (6 g.) was added dropwise with stirring. The product was worked up in the usual way, and distilled to give fraction (a) (1.5 g.) b.p. 96-97⁰/20 mm.; fraction (b) (2 g.) b.p. 153-155⁰/20 mm. and fraction (c) (4 g.) b.p. 196-200⁰/0.5 mm. A residue (1.5 g.) remained. Fraction (a) was identified as tetralin and fraction (b) as mainly iodotetralin. Fraction (c) was twice redistilled to give 4'-hydroxy-5-4'-phenylbutyltetralin (?), b.p. 189-190⁰/0.08 mm., η_D^{22} 1.5744 (Found: C, 86.2; H, 8.7; O, 5.6. $C_{20}H_{24}O$ requires C, 85.7; H, 8.6; O, 5.7%). However, vigorous dehydration in ethanol with sulphuric acid, followed by hydrogenation using Raney-nickel as catalyst gave a compound containing approximately 1% oxygen.

Method (ii) (a) Preparation. A current of dry ammonia gas (5 l./hr.) was passed for 4 hr. into a stirred suspension of ground calcium (4 g.) in a solution of 1-4'-phenylbutylnaphthalene (6 g.) in ether (75 c.c.) cooled in ice. The ethereal solution was filtered off and the

filter cake decomposed with water and hydrochloric acid. This was extracted with ether and the combined ethereal solutions dried over calcium chloride. The ether was removed and the residue distilled to give fractions (a) b.p. 167-175⁰/0.1 mm; and fraction (b) b.p. 175-177⁰/0.1 mm. Redistillation of (a) gave 1-4'-phenylbutyl-tetralin (2.5 g.) b.p. 178-180⁰/1 mm., η_D^{22} 1.5760 (Found: C, 90.9; H, 8.7. C₂₀H₂₄ requires C, 90.9; H, 9.1%). Analysis of fraction (b) showed incomplete reduction.

(b) Proof of structure. The reduced product above (2.5 g.) in water (100 c.c.) was heated with vigorous stirring on a water-bath and potassium permanganate (25 g.) added over 4 hr. When the oxidation was complete, the manganese dioxide was filtered off, the filtrate acidified with sulphuric acid, and extracted with ether in a continuous liquid extractor for 12 hr. Evaporation of the ether gave a white solid (0.5 g.). Esterification with diazomethane, followed by gas-liquid chromatography of the product, and comparison of retention times with authentic samples showed it to be essentially dimethyl-phthalate.

Method (iii) 5:5'-Ditetralyl-cadmium in benzene (20 c.c.) was prepared from magnesium (0.6 g.), 5-bromo-tetralin (5 g.) and cadmium chloride (2.5 g.), by the

method of Cason⁷¹. To this solution (cooled to 10°), was added, during three minutes, a benzene solution (5 c.c.) of phenylbutyryl chloride (4.3 g.), the temperature being kept below 40°. The mixture was stirred at 25-35° for 2 hr. and then poured onto ice and sulphuric acid, washed with sodium bicarbonate solution, brine, and finally dried and distilled. A product (4.5 g.) b.p. 210-260°/1 mm. was obtained. The first part (0.5 g.) of which formed a 2:4-dinitrophenylhydrazone derivative. Its infrared spectrum showed bands in the carbonyl region at 5.59, 5.68, 5.75, 5.85 and 5.93 μ . The remainder of the distillate showed bands at 5.50, 5.59, 5.68, 5.85, and 5.93 μ .

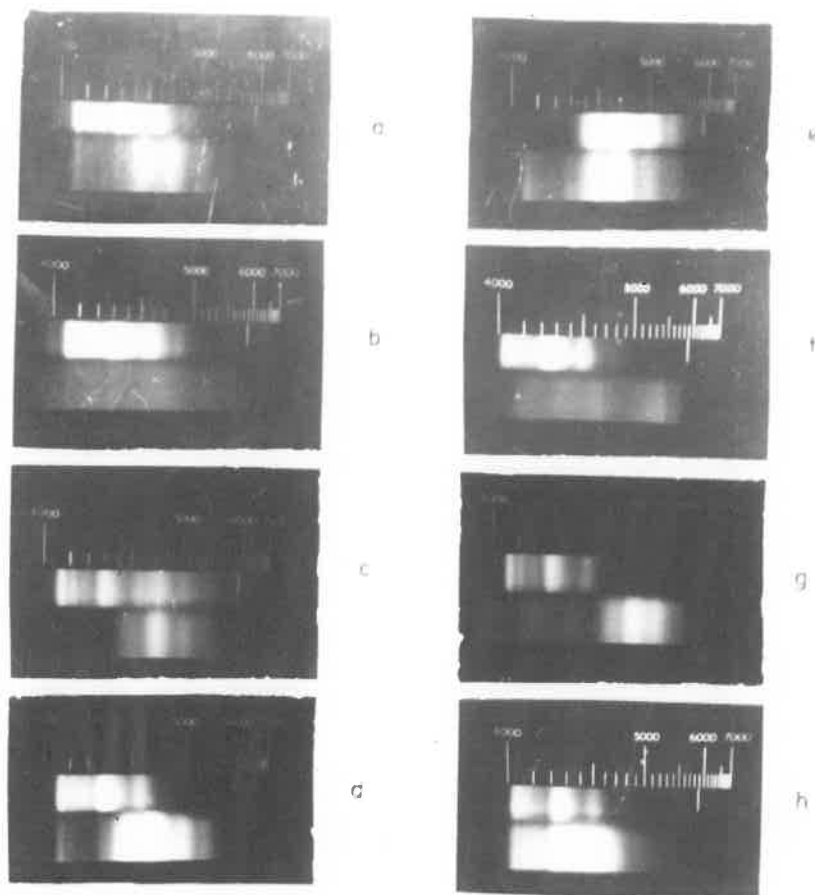

Plate 3-1. (a) 3:4-benzopyrene and perylene from pyrolysis at 360°; (b) 3:4-benzopyrene(?) from pyrolysis with Pd/C; (c) perylene from pyrolysis with charcoal; (d) & (e) perylene and 3:4-benzopyrene from pyrolysis at 600°; (f) unknown compound; (g) unknown compound; (h) 3:4-benzopyrene from pyrolysis at 600° of 1-4'-phenylbutyl-decalin. (For a, b, d, f, g, & h, the upper spectra are 3:4-benzopyrene; for c, a mixture of 3:4-benzopyrene and perylene; and for e, perylene).

CHAPTER IV

THE PYROLYSIS OF TETRALIN AND INDENE.

Tetralin

Tetralin is a possible intermediate in the formation of 3:4-benzopyrene at high temperatures, and the pyrolysis of this compound is therefore of interest (see Chapter I). Graebe showed that the pyrolysis of tetralin by passing it through a red hot tube gave naphthalene⁷². Benzene and homologues of benzene were reported following pyrolysis between 580-650^{73,74}; however, it has also been reported that at 700° naphthalene alone is formed⁷⁴. When superheated, tetralin is said to give chrysene⁷⁵. A complete analysis of the products formed by pyrolysing tetralin at 700° has been undertaken.

The pyrolysis was carried out by passing tetralin vapour, with nitrogen, through a silica tube filled with porcelain chips. It gave some gaseous products, among which methane and ethylene were identified. The semi-solid tar also obtained (in 72.5% yield), was collected and analysed by chromatography on alumina, gas-liquid partition chromatography, chromatography on acetylated paper⁴³, and by spectroscopy. The compounds detected,



TABLE 4.1.

PYROLYSIS PRODUCTS OF TETRALIN.

Product	Yield (g. & %) of tar ^a	How Identified ^b
Methane	? -	I.R.
Ethylene	? -	I.R.
Benzene	1.6, (2.28%)	R.T., I.R.
Toluene	0.6, (0.86%)	R.T., I.R.
Ethylbenzene	0.24, (0.34%)	R.T., I.R.
Styrene & <i>o</i> -xylene	0.6, (0.86%)	R.T., I.R.
Indene	2.6, (3.72%)	R.T., I.R.
Tetralin	1.0, (1.43%)	R.T., I.R.
Naphthalene	52.0, (74.4%)	mixed m.p.
1-, & 2-Me-naphthalene(?)	0.1, (0.14%)	R.T., I.R.
Diphenyl(?)	0.015, (0.02%)	R.T.
Unknown -X	0.015, (0.02%)	
2-Phenylnaphthalene	0.095, (0.14%)	R _f , U.V.
Phenanthrene	0.11, (0.16%)	U.V.
Anthracene	0.2, (0.29%)	U.V., F.S.
1:1'-Dinaphthyl(?)	0.07, (0.1%)	U.V.
1:2'-Dinaphthyl	0.40, (0.57%)	U.V.
2:2'-Dinaphthyl	0.93, (1.33%)	U.V., mixed m.p.

(Cont. on next page.)

TABLE 4-1. (Cont.)

Product	Yield (g. & %) of tar ^a	How Identified ^b
1:2-Benzofluorene	0.03, (0.04%)	U.V.
Fluoranthene	0.03, (0.04%)	U.V.
3:4-Benzophenanthrene	0.56, (0.79%)	R _T , U.V.
1:2-Benzanthracene	1.82, (2.60%)	U.V., F.S.
Pyrene	0.01, (0.01%)	R _T , U.V., F.S.
Chrysene	2.4, (3.43%)	U.V., mixed m.p. & analysis.
Perylene	0.18, (0.25%)	U.V., F.S.
11:12-Benzofluoranthene	0.19, (0.27%)	R _T , U.V.
3:4-Benzopyrene	0.12, (0.17%)	R _T , U.V., F.S.
Losses & unidentified	<u>6</u> (9%)	
	72.5g. (100%)	

a. i.e. weight obtained from 100 g. of tetralin.

b. R.T. = Retention time.

U.V. = Ultraviolet spectra.

I.R. = Infrared spectra.

F.S. = Fluorescence spectra.

their yields, and the manner in which they were identified are given in Table 4.1.

As expected, naphthalene is the major product, being formed by dehydrogenation of tetralin. It has been postulated (Chapter I) that tetralin, together with a $C_6 - C_4$ compound would give a C_{20} intermediate which by cyclodehydrogenation could give 3:4-benzopyrene. It may be noted that no $C_6 - C_4$ compounds have been found, but this does not exclude this as an intermediate in the formation of 3:4-benzopyrene in this tar as it would probably react to give further products. (In this connection it may be noted that no butylbenzene⁷ or 1-phenylbuta-1:3-diene⁹ remained unchanged after pyrolysis at 700°).

Bond dissociation energies of the carbon-carbon single bonds in the hydrogenated ring of tetralin will be similar (i.e. approximately 80 kcal./mole) and hence scissions will be expected to occur equally readily to give rise to the following primary radicals: (1) $C_6H_5^\bullet$, (2) $C_6H_5 \cdot CH_2^\bullet$, (3) $C_6H_5 \cdot CH_2CH_2^\bullet$, (4) $C_6H_5 \cdot CH_2CH_2CH_2^\bullet$, (5) $C_6H_5 \cdot CH_2CH_2CH_2CH_2^\bullet$, (6) $CH_3 \cdot C_6H_4 \cdot CH_2^\bullet$, (7) $CH_3CH_2 \cdot C_6H_4 \cdot CH_2^\bullet$, (8) $CH_3CH_2 \cdot C_6H_4 \cdot CH_2CH_2^\bullet$, and (9) $CH_3CH_2CH_2 \cdot C_6H_4 \cdot CH_2^\bullet$, together with their counterparts with the electrons localised on alternative carbon atoms.

Reaction of radicals (1), (2), (3), and (6) with hydrogen accounts for the presence of benzene, toluene, ethylbenzene, and *o*-xylene, while styrene is readily obtained by dehydrogenation of ethylbenzene. The absence of the corresponding products from the other radicals suggest that they readily cyclise, or that further scission of carbon-carbon bonds occur to give shorter chain products together with methane or ethylene. Indene would be formed by cyclisation of radicals (4) or (7). However, the pyrolysis of propyl benzene gives very little indene⁷.

2-Phenylnaphthalene could be formed by phenyl radical attack on naphthalene or by dimerisation of styrene as suggested by Badger and BATTERY⁸. A direct radical attack on naphthalene would be expected to give 1-phenylnaphthalene as the major product, but this could not be detected. However, this compound has a very unspecific ultraviolet absorption spectrum, and although somewhat similar curves were found, no definite conclusions could be drawn. Fluoranthene is known to be formed by cyclodehydrogenation of 1-phenylnaphthalene⁷⁷. This probably accounts for the small yield of fluoranthene found in the tar.

The phenanthrene could have been formed either from diphenyl and ethylene or from two benzyl radicals

indicated by reaction (1). The latter could also give rise to anthracene as indicated by reaction (2).

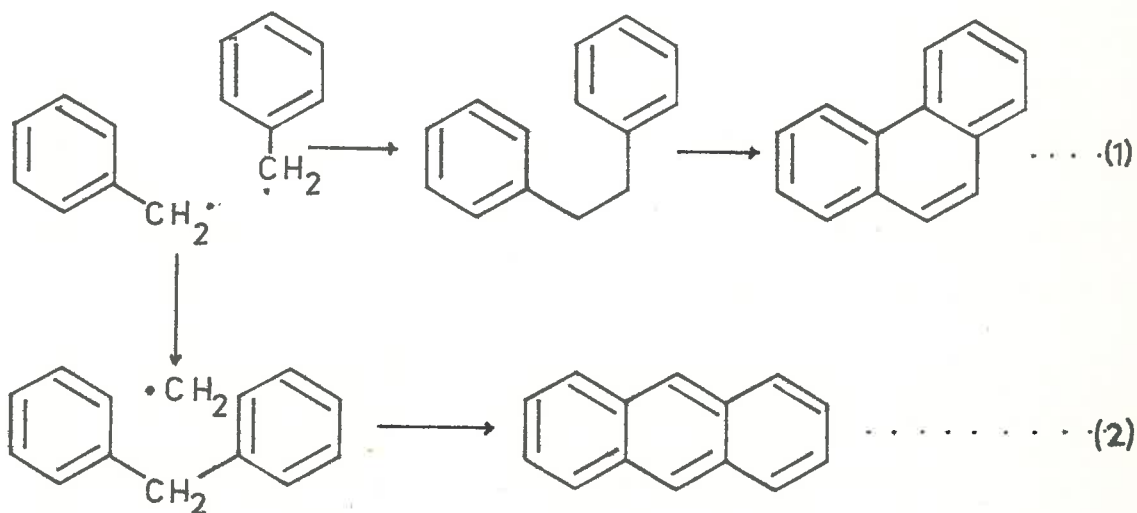

The stability of benzyl radicals⁷⁸ suggests that reactions involving it as an intermediate could be expected.

Dimerisation of naphthalene, or of tetralin followed by dehydrogenation, would give the dinaphthyls. At high temperatures steric factors will have more influence than electrical effects. This together with the fact that both 1:1'- and 1:2'-dinaphthyl can cyclise to give other compounds is perhaps the reason for the larger yield of 2:2'-dinaphthyl.

1:2-Benzofluorene could be formed by benzyl radical attack on naphthalene followed by ring closure as

indicated by reaction (3), or in a similar manner as proposed from indene (see below).

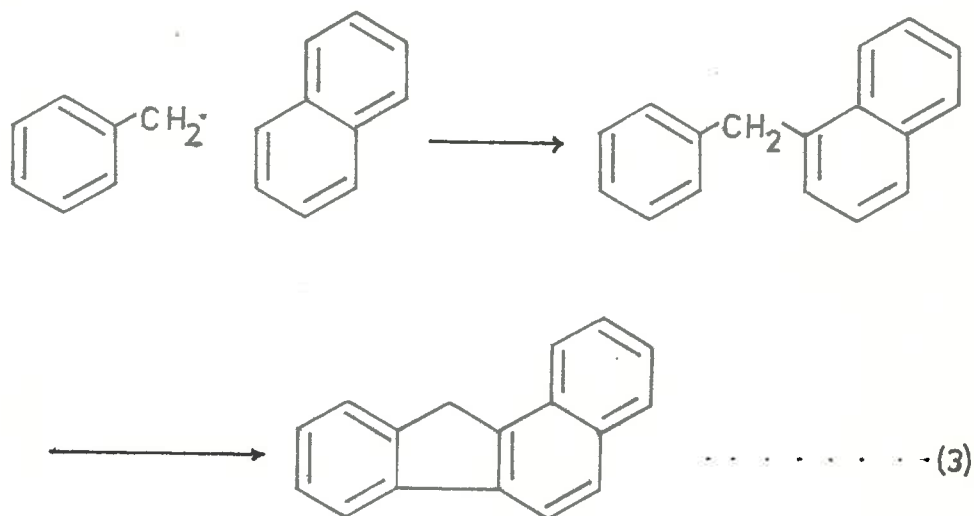

The pyrolysis of indene has been reported to give large quantities of chrysene⁷⁹. The chrysene detected, could be formed in this way. A reinvestigation of the pyrolysis of indene, at 700° (see below), has shown also, the presence of 1:2-benzanthracene and 3:4-benzophenanthrene, and it seems more likely, taking into consideration the larger relative yield of chrysene compared with 1:2-benzanthracene and 3:4-benzophenanthrene, that from tetralin, its formation would involve the radicals, $\text{C}_6\text{H}_5\text{-CH}_2\text{CH}_2\text{CH}_2^\cdot$, and $\text{CH}_3\text{CH}_2\text{-C}_6\text{H}_4\text{-CH}_2^\cdot$, before cyclisation

to indene has occurred. Combination of these radicals can occur in the ways (I - IV). Therefore chrysene, 1:2-benzanthracene, 3:4-benzophenanthrene, and triphenylene could all conceivably be formed.

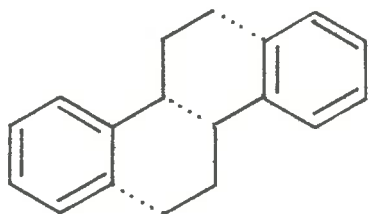

(I a)

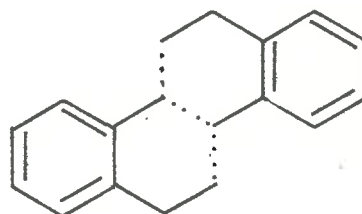

(I b)

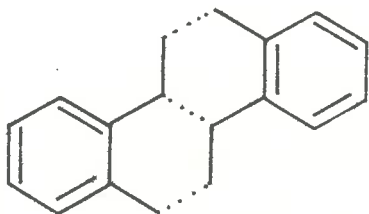

(I c)

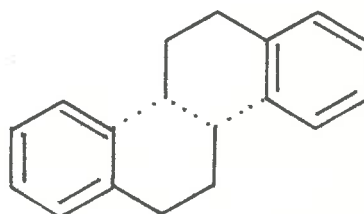

(I d)

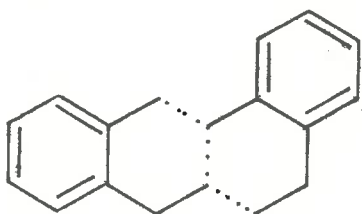

(II a)

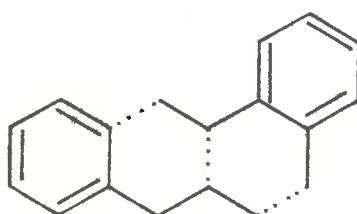

(II b)

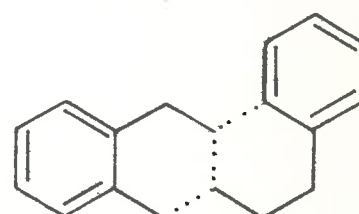

(II c)

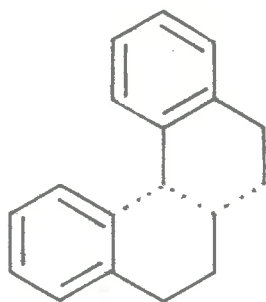

(III)

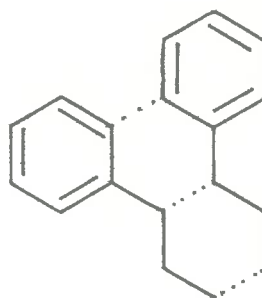

(IV)

However, no triphenylene has been found. Various factors may be involved in an explanation of this apparent anomaly. Firstly, benzyl radicals are known to be relatively stable⁷⁸. One can imagine that when arranged in the sense (Ib and IIa) the reaction could involve two substituted benzyl radicals reacting to give a disubstituted dibenzyl which could then cyclodehydrogenate to give chrysene and 1:2-benzanthracene respectively. Similarly, when arranged in the sense (Ic, IIb, IIc, and III) the reaction could involve a substituted benzyl and another radical.

The remaining arrangements all involve two units with three-carbon side-chains. Secondly, therefore, one can imagine that these longer side-chains will move around more rapidly under pyrolysis conditions than their

heavier parent rings. Hence one can reasonably suppose that ω, ω' side-chain attack is less likely to occur as often as ω side-chain attack on a more slowly moving parent ring. Nevertheless, it seems likely that ω, ω' attack is the most reasonable mechanism for the formation of triphenylene as (i) dinuclea attack will be retarded due to steric factors, and (ii) α, α' attack to give o-terphenyl as intermediate would certainly cyclise to give triphenylene. One would then expect to find very little triphenylene. The ratio of 4:3:1 of the yields of chrysene : 1:2-benzanthracene : 3:4-benzophenanthrene is as expected from the above, provided each possible combination has approximately equal possibility of occurring.

The very small amount of pyrene present may be formed from phenanthrene and ethylene, or possibly from two molecules of styrene. Pyrolysis of 1:1'-dinaphthyl with palladium-charcoal, is known to give perylene⁸⁰ and this is probably the intermediate in its formation here.

11:12-Benzofluoranthene is probably formed from 1:2'-dinaphthyl by cyclodehydrogenation as shown by reaction (4).

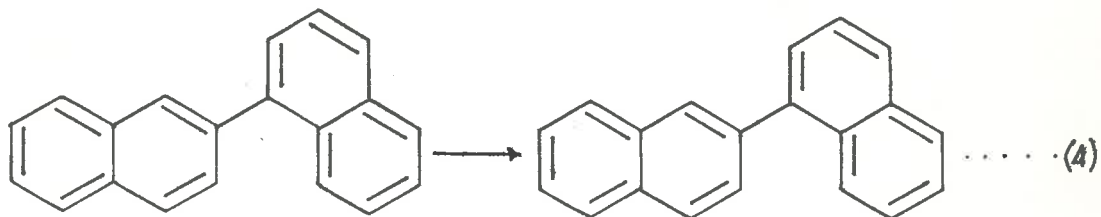

3:4-Benzopyrene may be formed from the proposed intermediate (V); however, considering the relatively

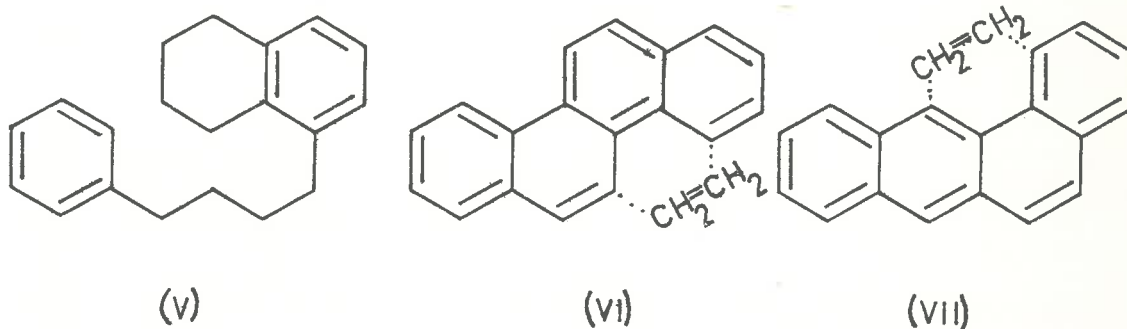

large yields of chrysene and 1:2-benzanthracene, it may be more reasonable to suppose that the benzopyrene is formed from ethylene and these compounds as indicated by (VI) and (VII). Evidence from the indene work, however, indicates that the latter are not likely mechanisms (see below).

Indene

The pyrolysis of indene by passing it through a red hot tube in the hands of Spilker⁷⁹, gave chrysene (15%) with indene (75%) recovered. A thorough analysis with more modern techniques was considered advisable, especially in view of the possibility of the formation of 1:2-benzanthracene and 3:4-benzophenanthrene from indene at high temperatures.

The pyrolysis was carried out in the same way as for tetralin. The gaseous products were found to contain, as usual, methane and ethylene. The solid tar also obtained (in 51.6% yield), was collected and analysed by chromatography on alumina, gas-liquid partition chromatography, chromatography on cellulose acetate⁴⁴ and on acetylated paper, and by spectroscopy. The compounds obtained and their yields, together with the manner in which they were identified are given in Table 4.2.

Chrysene was the major product, but was present in smaller quantity than expected from the literature⁷⁹.

Taking account of the bond orders of the carbon-carbon bonds in indene⁸¹, approximate values for their bond dissociation energies can be obtained (VIII).

TABLE 4.2.

PYROLYSIS OF PRODUCTS OF INDENE.

Product	Yield (g. & %) of tar ^a	How Identified ^b
Methane	? -	I.R.
Ethylene	? -	I.R.
Benzene	2.6, (5.4%)	R.T., I.R.
Toluene	0.4, (0.83%)	R.T., I.R.
Styrene(?)	0.05, (0.1%)	R.T.
Unknown -X	1.1, (2.3%)	
Indene	3.12, (6.5%)	R.T., I.R.
Naphthalene	2.9, (4.6%)	R.T., mixed m.p.
Fluorene	0.01, (0.02%)	U.V.
Phenanthrene	0.18, (0.38%)	U.V., mixed m.p.
Anthracene	0.10, (0.20%)	U.V., F.S.
3:4-Benzophenanthrene	1.1, (2.3%)	R _F , U.V., mixed m.p.
Unknown -Y	0.25, (0.52%)	
Pyrene	0.05, (0.10%)	R _F , U.V., F.S.
Fluoranthene	0.13, (0.27%)	U.V., F.S.
1:2-Benzofluorene	2.1, (4.4%)	U.V.
2:3-Benzofluorene	2.15, (4.5%)	R _F , U.V., mixed m.p.
3:4-Benzofluorene	0.5, (1.0%)	U.V.

(Cont.) on next page.)

TABLE 4*2. (Cont.)

Product	Yield (g. & %) of tar ^a	How Identified ^b
1':2':3':4'-Tetrahydro-3:4-benzopyrene(?)	0.22, (0.46%)	U.V.
1:2-Benzanthracene	2.2, (4.6%)	R _F , U.V., F.S., mixed m.p.
Alkylchrysene	0.5, (1.1%)	U.V.
Chrysene	15.2, (31.7%)	R _F , U.V., mixed m.p.
3:4-Benzofluoranthene	0.004, (0.008%)	R _F , U.V., F.S.
10;11-Benzofluoranthene	0.005, (0.01%)	U.V.
11:12-Benzofluoranthene	trace	R _F , U.V., F.S.
3:4-Benzopyrene	0.001, (0.002%)	R _F , U.V., F.S.
Very high b.p. tar	7.5, (16%)	
Loses & unidentified	5.6, (11%)	
	<u>48 g. (100%)</u>	

a. i.e. weight obtained from 93 g. of indene.

b. R.T. = Retention time.

U.V. = Ultraviolet spectra.

I.R. = Infrared spectra.

F.S. = Fluorescence spectra.

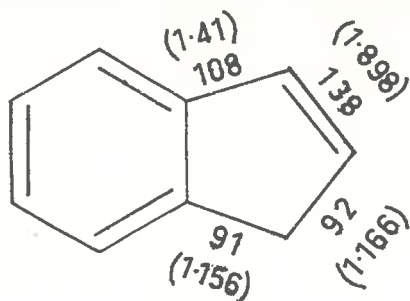

(VIII)

It would seem then that the carbon-carbon double bond has a bond dissociation energy of ca. 138 kcal./mole, and the carbon-carbon single bond linking this conjugated double bond to the benzene ring, a bond dissociation energy of ca. 108 kcal./mole. The remaining two carbon-carbon bonds in the five membered ring will have dissociation energies of approximately 90 kcal./mole. Ring fission would then be expected to give rise to the primary free radicals (IX), (X), and (XI).

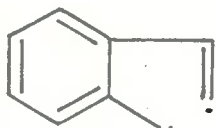

(IX)

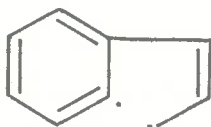

(X)

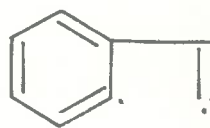

(XI)

It seems unlikely that these diradicals will be stable for any length of time. One could imagine that in the case of (IX), the diradical would react very quickly with

hydrogen radicals to give the relatively stable benzyl radical (XII). In the case of the diradicals (X) and (XI), one or other part could undergo termination reactions with hydrogen radicals to give the more stable mono-radicals (XIII) and (XIV).

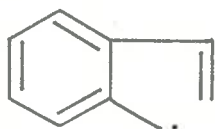

(XII)

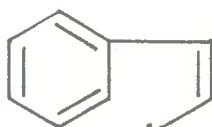

(XIII)

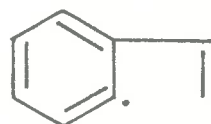

(XIV)

Chrysene, 1:2-benzanthracene, and 3:4-benzophenanthrene could be expected to be formed from radicals (XII), and (XIII), by arrangement in the ways (XV), (XVI), and (XVII). The rate of addition of free radicals to unhindered double bonds is far greater than the rate of hydrogen abstraction from single bonds⁸².

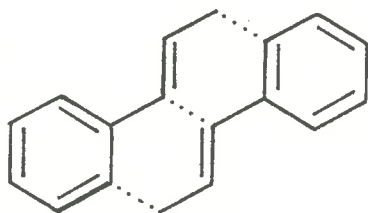

(XV a)

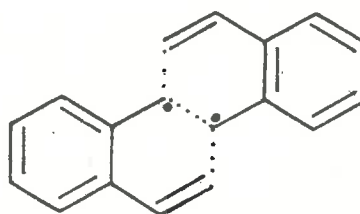

(XV b)

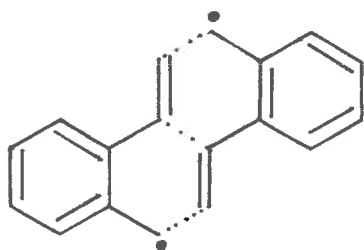

(XVc)

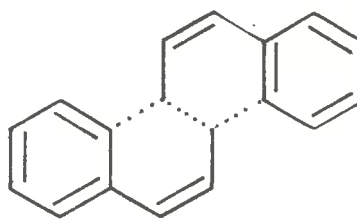

(XVd)

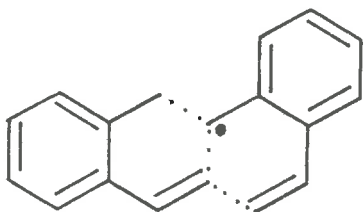

(XVIa)

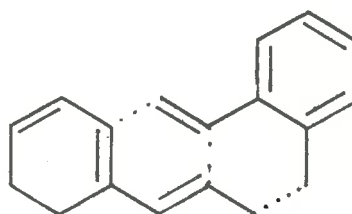

(XVI b)

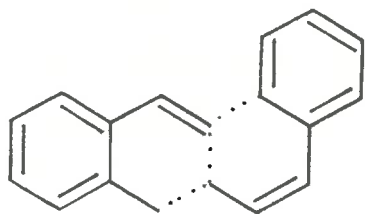

(XVI c)

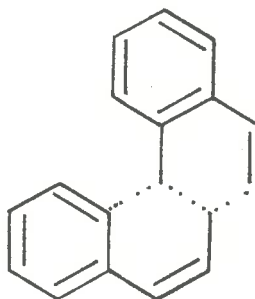

(XVII)

Styrene is particularly reactive and the arrangements (XVb), (XVc), (XVIa), (XVIb), (XVIc) and (XVII) all involve this type of free radical attack. Of these (XVb) and (XVc) both involve two benzyl-type radical to double

bond attacks, while (XVIa) involves one. The others either do not involve benzyl-type radicals or double bonds or both, and hence would not be expected to play as important a part in the formation of these compounds. Taking these effects into consideration, one would then expect the ratio of chrysene to 1:2-benzanthracene to be approximately 4:1 (i.e. as there are four benzyl radical-double bond attacks for the formation of chrysene, and one for the formation of 1:2-benzanthracene).

The mechanism for their formation, in the absence of the double bond, as proposed for the tetralin pyrolysis, supported the 4:3:1 ratio of the yields obtained of chrysene, 1:2-benzanthracene, and 3:4-benzophenanthrene. The presence of the radical-double bond attack would be expected to increase the yields of all of these compounds, and also taking into consideration the above special effects, the yields of chrysene would be expected to be increased the greatest amount. Experimentally the ratio of chrysene:1:2-benzanthracene : 3:4-benzophenanthrene was found to be 13:2:1.

Radicals (XII) and (XIV), and (XIII) and (XVI) may also be arranged in various ways in order to form 1:2-, 2:3-, and 3:4-benzofluorene, (XVIII), (XIX), and (XX).

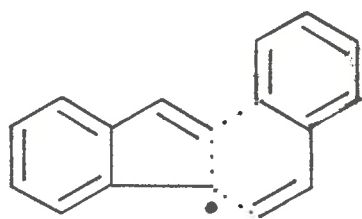

(XVIII a)

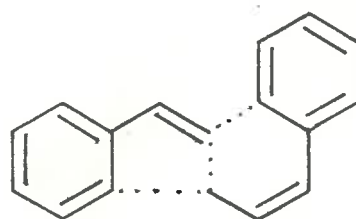

(XVIII b)

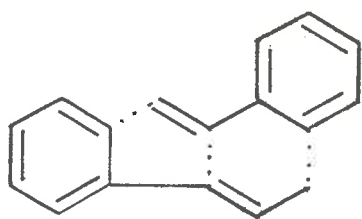

(XVIII c)

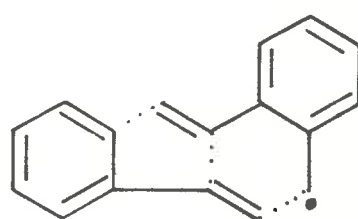

(XVIII d)

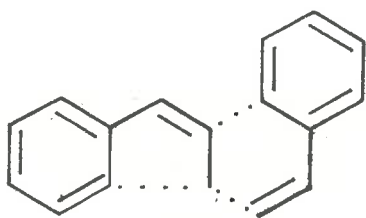

(XVIII e)

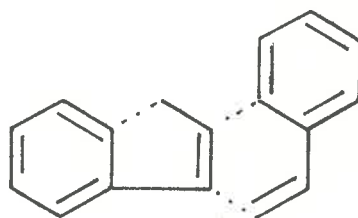

(XVIII f)

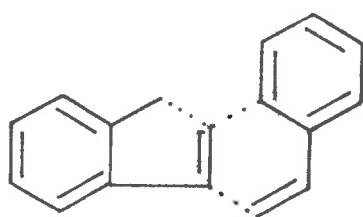

(XVIII g)

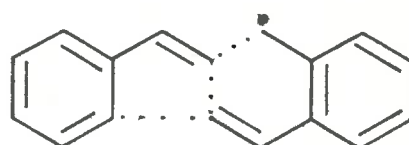

(XIX a)

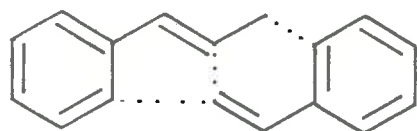

(XIX b)

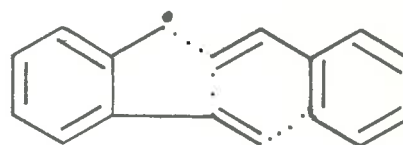

(XIX c)

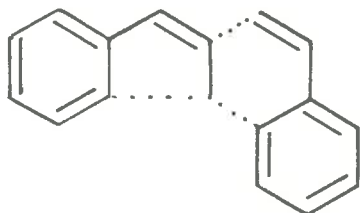

(XX d)

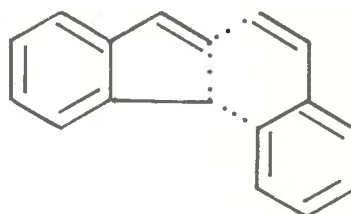

(XX b)

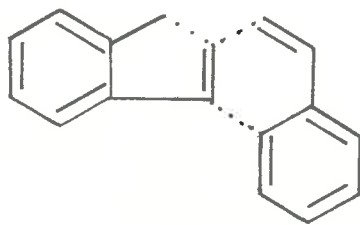

(XX c)

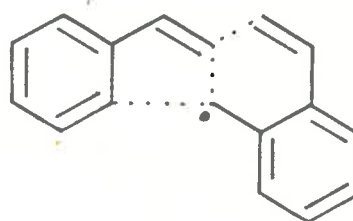

(XX d)

However, of these only those arranged in the sense (XVIIIa), (XVIII d), (XIXa), (XIXc), and (XXd) involve the most reactive benzyl radical-double bond attack. One can then imagine that the ratios of the yields may be of the order of 2:2:1. In fact, experimentally it is 4:4:1. This is not inconsistent with the theoretical

considerations, especially as there are doubtless other factors involved, and also the ultraviolet spectrum of 3:4-benzofluorene is not very easy to detect in mixtures with the other benzofluorenes.

The reaction of the styryl radical (XIV) with hydrogen would account for the small amount of styrene obtained. Secondary fission of this radical, involving the breaking of the carbon-carbon bond linking the ethylenic group to the benzene ring, would account for the benzene and some of the ethylene. (The pyrolysis of styrene⁸ at 710° gives benzene in 6.4% yield). The toluene is also probably obtained through a secondary fission of the radical (XII), followed by reaction with hydrogen. Reaction between the benzyl radicals formed and benzene, would explain the presence of fluorene, and that between two benzyl radicals would account for the presence of the phenanthrene and anthracene (see above).

The fluoranthene may be formed from two C₆ - C₂ units, or from a C₆ - C₃ and a C₆ - C₁ unit, and probably goes through 1-phenylnaphthalene⁷⁷ as an intermediate (Reaction 1).

The very small amount of pyrene present could be formed in numerous ways (e.g. from styrene, m-xylene⁸³, etc.), but there is no evidence to support any particular

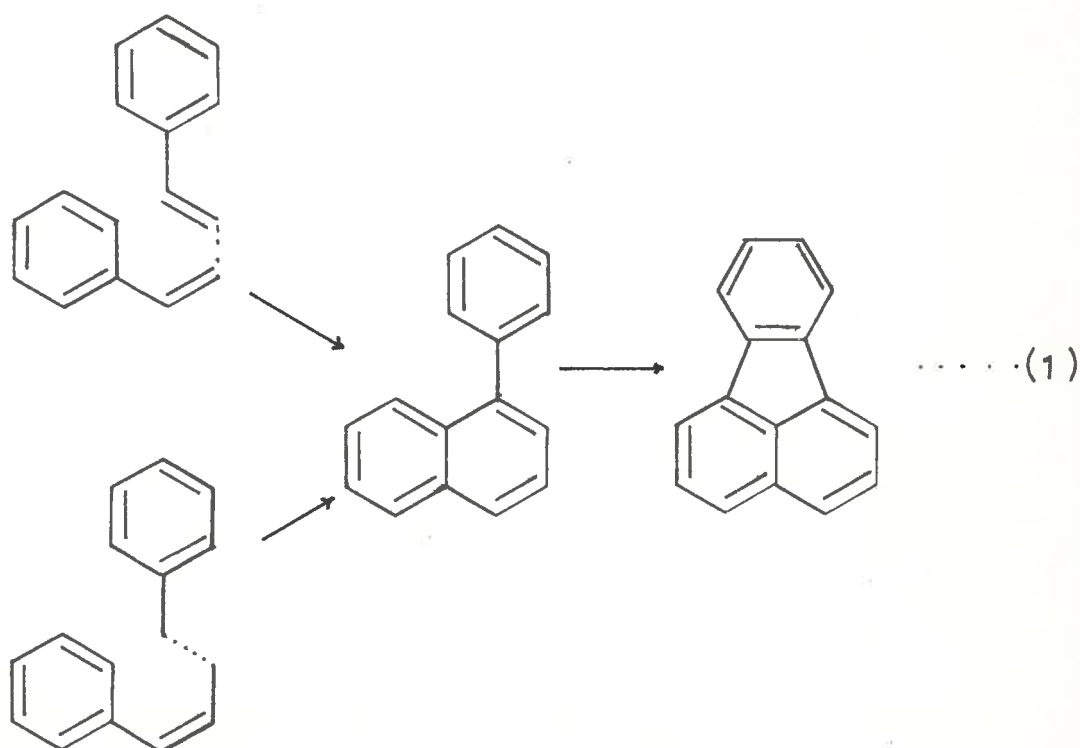

mechanism. The formation of naphthalene can only be explained if chain lengthening occurs, e.g. the attack of ethylene on the styryl radical (XIV), or even from a $C_6 - C_3$ unit and methane. The presence of a $C_6 - C_4$ hydrocarbon can then easily explain the presence of the very small amounts of 3:4-, 10:11-, and 11:12-benzofluoranthene and 3:4-benzopyrene by arrangement of two units as in (XXI), (XXII), (XXIII), and (XXIV).

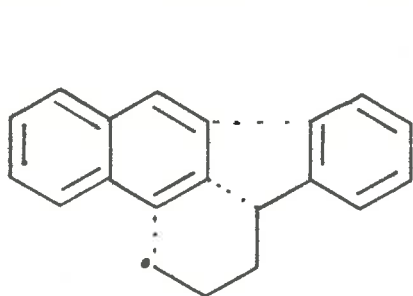

(XXI)

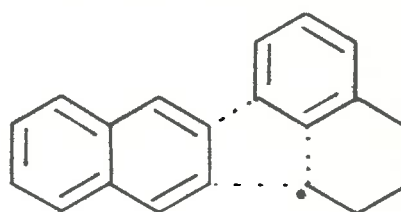

(XXII)

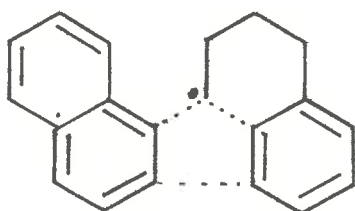

(XXIII)

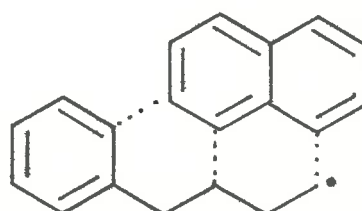

(XXIV)

It can be reasonably concluded, also, from this work that 3:4-benzopyrene is not formed in pyrolyses, at this temperature, from chrysene and a C_2 hydrocarbon (e.g. ethylene), or from 1:2-benzanthracene and a C_2 hydrocarbon. These hydrocarbons are all present in considerable amount, and should give a relatively large yield of 3:4-benzopyrene if it was formed to any significant extent by these mechanisms.

This indene-tar contained an unusually large amount of very high boiling material (16%), which could not be

identified. Indene is known to undergo ready polymerisation on heating⁸⁴, and this probably accounts for a large proportion of the unidentified material.

EXPERIMENTAL.

Tetralin.-- Technical tetralin (B.D.H.) was sulphonated and purified by the method of Schroeter⁸⁵. The pure tetralin b.p. 100-101°/25 mm., η_D^{14} 1.5453 (lit. η_D^{20} 1.5451)⁸⁶, was shown to contain no naphthalene by gas-liquid chromatography.

Pyrolysis of Tetralin at 700°.-- Tetralin (100 g.) was passed at the rate of 6 drops/min. with nitrogen (1 c.c./sec.) through a silica tube (36 x 1 in.) packed with porcelain chips ($\frac{1}{8}$ - $\frac{1}{4}$ in.) heated to 700° in the furnace previously described (see Chapter I). The semi-solid tar (70 g.) resulting, was collected and the gaseous products also formed, having first been passed through a trap cooled in a dry-ice/ethanol mixture were found to decolourise bromine water, and neutral and alkaline permanganate. Samples of the gaseous products were examined in the infrared spectrometer.

Analysis Techniques.-- (1) Gas-liquid partition chromatography. The distillation fractions with b.p. up to 160°/0.3 mm. were examined by gas-liquid chromatography, using a Griffin and George vapour phase chromatographic apparatus (Mk.II) modified to collect

samples⁴². The column was packed with Apiezon-L supported on Celite (40-80 mesh, B.S.S.; 1:4, w/w). Varying conditions of temperature, pressure, and nitrogen flow rate were used to suit the various fractions. The compounds were collected and identified by infrared spectroscopy and the percentage composition determined from the areas under the peaks.

(ii) Chromatography on acetylated paper. All the fractions collected from chromatography on alumina were chromatographed on acetylated paper⁴³ using, ethanol-toluene-water (17:4:1) as developing solvent. The fractions containing essentially the same compounds, shown by the positions of their spots under ultraviolet light, were combined and rechromatographed on paper, using larger amounts of material. After development with methanol-ether-water (4:4:1), or with ethanol-toluene-water (17:4:1) followed by thorough drying in an oven, the fluorescent spots were cut out, extracted with 95% ethanol, and ultraviolet spectra taken using an Optica CF₄ Spectrophotometer recording instrument. The position of non-fluorescent materials on the paper was found by contact printing their position on Ilford Reflex Document paper No. 50, using an ultraviolet light source emitting

90% of the 2537A⁰ mercury line. The amounts present were determined from their ultraviolet spectra by comparison with optical densities of authentic spectra of known concentration. Sometimes, spots required rechromatographing on paper once or twice in order to purify the compound.

Details of Chromatography.- The pyrolysis tube and porcelain chips were washed with chloroform and the residue (0.5 g.), after removal of the solvent, added to the main bulk of the tar and the whole distilled to give (a) b.p. 40-80⁰/14 mm. (0.8 g.); (b) b.p. 90-95⁰/14 mm. (56 g.); and (c) the residue (9 g.). Fractions (a) and (b) were submitted to gas-liquid chromatography (see above). Fraction (a) was found to contain toluene, ethylbenzene, styrene, *o*-xylene and indene; and fraction (b) indene, tetralin and naphthalene. The essentially crystalline residue was washed with cold benzene and the pale yellow crystalline material (2 g.) remaining, extracted in a hot Soxhlet apparatus with hexane. Chromatography on alumina of the extracted product, followed by paper chromatography on acetylated paper showed it to be practically pure chrysene (see below).

The benzene washings were evaporated to give a dark

residue (7 g.), which was taken up in a minimum quantity of benzene-hexane (1:1) and chromatographed on alumina. Elution with hexane gave fractions (70 c.c. each) 1 - 16, with benzene-hexane (1:4) fractions 17 - 23, with benzene-hexane (1:2) fractions 24 - 31, with benzene-hexane (1:1) fractions 32 - 37, with benzene-hexane (2:1) fractions 38 - 41, with benzene fractions 42 - 45, and with benzene-chloroform (1:1) fractions 46 - 49). Fractions 1 - 21, which were oily, were combined and distilled to give fractions (d) b.p. 95-210°/19 mm. (0.5 g.); (e) b.p. 155-160°/0.3 mm. (0.2 g.); and (f) a residue (1.2 g.). Gas-liquid chromatography of fraction (d) showed the presence of naphthalene, 1- and 2-methylnaphthalene(?), diphenyl(?) and unknown -X.

Paper chromatography and ultraviolet spectroscopy was used to show that fraction (e) contained a mixture of anthracene, phenanthrene, fluoranthene, pyrene and 2-phenylnaphthalene. The residue (f) was chromatographed on alumina and elution with light petroleum, hexane, and benzene-hexane (1:4) gave 20 fractions (70 c.c. each), the composition of which were determined by paper chromatography and ultraviolet spectroscopy. This technique showed the presence of 1:1'-, 1:2'-, and 2:2'-dinaphthyl, 2-phenylnaphthalene, 1:2-benzofluorene,

1:2-benzanthracene, and 3:4-benzophenanthrene. Fractions 22 - 49 of the original chromatogram were further analysed by paper chromatography and were found to contain perylene, chrysene, 11:12-benzofluoranthene and 3:4-benzopyrene.

Details of Identification.- Methane and ethylene.

The gaseous products from the furnace were collected in a gas cell for infrared analysis. Methane was identified by its spectrum⁵⁰ in the 7.5-8.5 μ region (maxima at 7.61, 7.73, 7.77, 7.81, 7.85, 7.90, 7.94, 7.98, 8.05, 8.11, 8.17, 8.22, and 8.31 μ), and ethylene by its spectrum⁵⁰ in the 9.0-11.5 μ region (maxima at 9.33, 9.44, 9.53, 9.63, 9.72, 9.79, 9.83, 9.91, 10.01, 10.11, 10.20, 10.30, 10.51, 10.75, 10.83, 10.92, 11.00, 11.07, 11.16, 11.24, and 11.35 μ).

Benzene. The benzene (1.6 g.) was found in the dry-ice/ethanol trap together with a small amount of toluene (0.4 g.). Separation by gas-liquid chromatography gave pure benzene, shown by its infrared spectrum⁵⁰ (maxima at 2.40, 3.23, 5.05, 5.47, 6.65, 6.71, 7.18, 9.51, 9.62, 9.75, 12.82, 14.55, and 14.90 μ).

Toluene. This was identified by its infrared

spectrum⁵⁰ in the 2-8 μ region (maxima at 2.16, 2.31, 2.35, 2.47, 2.60, 2.74, 3.29, 3.31, 3.42, 3.48, 3.67, 3.90, 4.17, 4.45, 4.64, 5.04, 5.11, 5.14, 5.34, 5.38, 5.50, 5.55, 5.76, 6.85, and 7.29 μ).

Ethylbenzene. This also was identified by its infrared spectrum; with maxima at 2.30, 2.70, 3.25, 3.32, 3.35, 3.41, 3.60, 3.78, 4.10, 4.30, 5.10, 5.31, 5.50, 5.71, 6.08, 6.85, 7.22, 7.48, 8.46, 8.62, 9.01, 9.20, 9.40, 9.70, and 11.03 μ , in agreement with the literature⁵⁰.

Styrene and o-xylene. A mixture isolated by gas-liquid chromatography was shown to contain both styrene and o-xylene. Styrene was identified by its infrared maxima at 2.12, 2.25, 2.41, 2.70, 3.26, 3.30, 3.61, 5.10, 5.29, 5.45, 5.70, 5.89, 6.10, 6.70, 6.88, 7.05, 7.20, 7.47, 7.57, 7.75, 8.30, 8.46, 8.65, 9.05, 9.25, and 11.00 μ , in agreement with the literature⁵⁰, and o-xylene by five maxima at 3.40 (infl.), 4.08, 4.27, 8.91, and 9.50 μ . This fraction decolourised bromine water.

Indene. This was identified by its maxima at 2.15, 2.32, 2.39, 2.52, 3.00, 3.26, 3.42, 3.58, 3.71, 3.82, 4.07, 4.86, 5.12, 5.20, 5.27, 5.36, 5.44, 5.54, 5.74,

5.90, 6.00, 6.86, 7.17, 7.35, 7.49, 7.61, 7.77, 8.57, 8.66, 8.90, 9.38, 10.59, 10.81, and 10.93 μ , in agreement with those obtained on an authentic specimen.

Tetralin. Recovered by gas-liquid chromatography of fraction (b) this was identified by its retention time and by its infrared spectrum.

Naphthalene. Obtained from fractions (b) and (d) this had m.p. and mixed m.p. 79-80°.

Methylnaphthalenes(?). Gas-liquid chromatography of fraction (d) gave a peak with a shoulder similar to that given by a mixture of authentic 1- and 2-methylnaphthalene, and with the same retention times.

Diphenyl(?). A further small peak obtained by gas-liquid chromatography of fraction (d) had the same retention time as an authentic specimen of diphenyl.

2-Phenylnaphthalene. This was identified by its ultraviolet absorption spectrum of extracts of spots obtained in paper chromatograms of fractions (e) and (f). It had maxima at 250 and 287 $m\mu$. The literature⁸⁷ gives maxima at 251 and 288 $m\mu$.

Anthracene. Fraction (e) was recrystallised from

petroleum ether, and after sublimation, the product had an ultraviolet absorption spectrum having maxima at 252, 323, 339, 357, and 375 $m\mu$ with inflexions at 246, 352, and 371 $m\mu$ indicative of anthracene⁴⁶. This was confirmed by its fluorescence spectrum (Plate 4·1a). A broad diffuse band in the 430 to 470 $m\mu$ region was caused by impurities.

Phenanthrene. Paper chromatography of the mother liquor of recrystallised fraction (e) (above) gave several spots. The ultraviolet absorption spectrum of the ethanol extract of one spot had maxima at 246 (infl.), 251, 274, 282, and 293 $m\mu$ indicative of phenanthrene⁴⁶.

Fluoranthene and pyrene. The extract of another spot had maxima at 233 (infl.), 236, 253 (infl.), 262, 272, 277, 282, 288, 309, 323, 342, and 360 $m\mu$ characteristic of fluoranthene⁴⁶. Maxima at 242, 319, and 335 $m\mu$ suggested the presence of some pyrene. This was confirmed by its fluorescence spectrum.

1:1'-Dinaphthyl(?) and 1:2'-dinaphthyl. Paper chromatography of the fractions resulting from the chromatography of fraction (f) on alumina, gave several violet-blue spots of high R_f . One such spot when

extracted with ethanol had an ultraviolet absorption spectrum with maxima at 219 and 283, with inflexions at 225 and 273 μ identical with 1:2'-dinaphthyl⁶⁸.

However, another spot differed slightly, with maxima at 221, 272, and 283 with an inflexion at 292 μ . This spectrum suggested a mixture of 1:1'-dinaphthyl and 1:2'-dinaphthyl by comparison with the literature⁶⁸. (Fig. 4.1)

2:2'-Dinaphthyl. This was isolated mainly from the original chromatogram on alumina. Recrystallisation from benzene-hexane (1:4) gave colourless plates m.p. 184-185^o, mixed m.p. 184-186^o and infrared and ultraviolet absorption spectra identical with those for an authentic sample.

3:4-Benzophenanthrene. Chromatography on alumina of fraction (f) gave by elution with light petroleum several oily fractions which gave a broad intense blue spot on acetylated paper. Ultraviolet absorption spectroscopy showed numerous maxima which could not be identified with any one compound. However, micro-distillation of the oil b.p. 150-155^o/0.05 mm., gave a semi-solid product which formed a picrate. Recrystallisation three times gave orange-red plates m.p. 118-121^o. After breaking down the complex with dilute

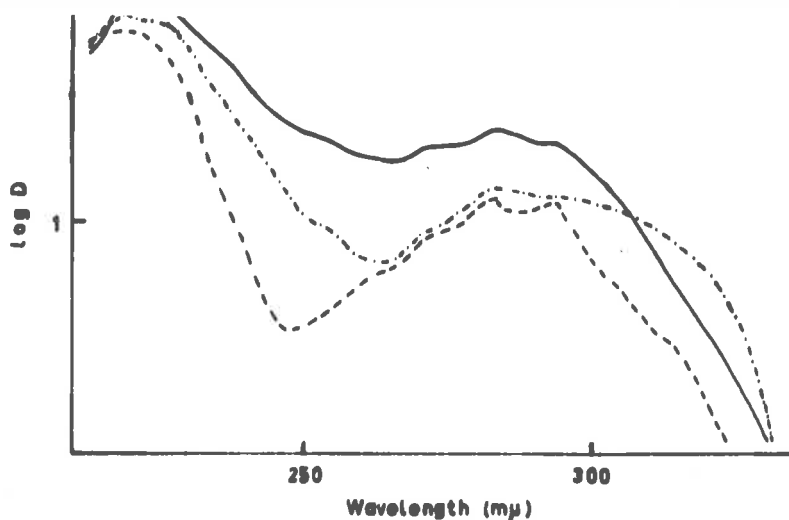

Fig. 4.1. Mixture of 1:1'- and 1:2'-dinaphthyl from tetralin pyrolysis (—); Authentic 1:1'-dinaphthyl (---), and 1:2'-dinaphthyl (-·-·).

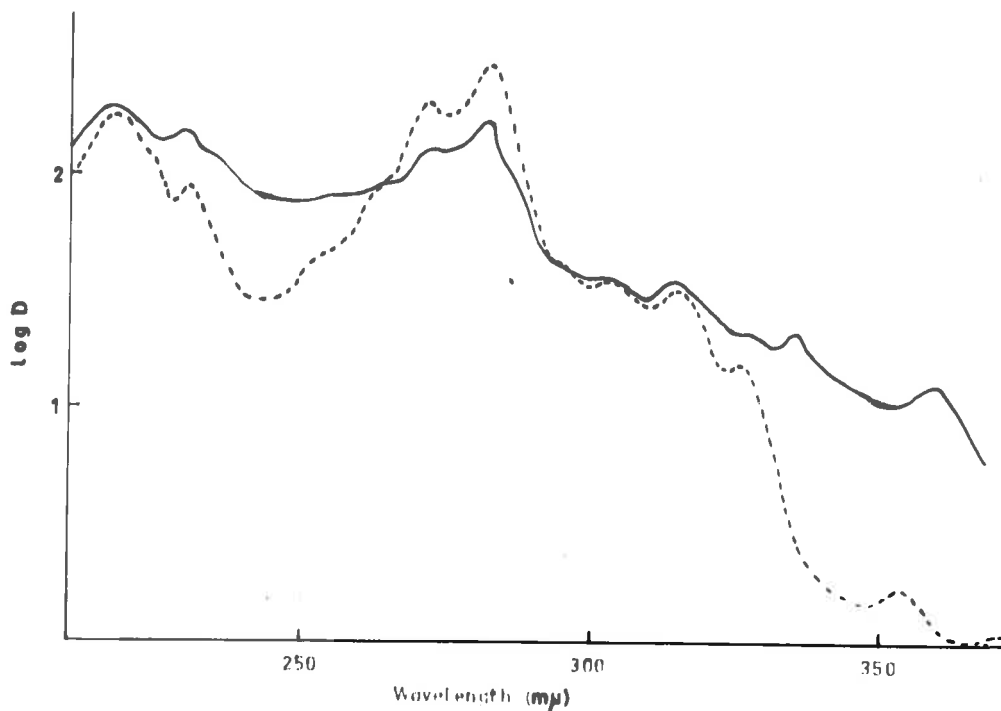

Fig. 4.2. 3:4-Benzophenanthrene from pyrolysis of tetralin (—). Authentic (---).

ammonium hydroxide and extraction with ether, the product was again paper chromatographed. The ultraviolet absorption spectrum of the violet-blue spot had maxima at 218, 230, 272, 282, 304 (infl.), 315, and 326 (infl.) μ indicative of 3:4-benzophenanthrene⁴⁶. (Fig. 4-2).

1:2-Benzanthracene. Isolated by chromatography on acetylated paper of fraction (f), this was identified by its absorption maxima at 222, 228, 254, 258, 263, 278, 288, 300, 314, 325, 340, 359, 373, and 384 μ and by its fluorescence spectrum with bands at 408, 435, and 464 μ both in agreement with the literature⁴⁶. (Plate 4-1b).

Chrysene. Recrystallisation of the crude product from benzene gave pure chrysene m.p. and mixed m.p. 251-252°. (Found: C, 94.9; H, 5.3. Calc. for $C_{18}H_{12}$: C, 94.7; H, 5.3%). This was confirmed by ultraviolet absorption spectroscopy with maxima at ($\log \epsilon$ in parenthesis) 220 (4.45), 241 (4.25), 259 (4.80), 268 (5.10), 283 (4.10), 295 (4.07), 307 (4.11), 320 (4.10), 343 (2.80), and 361 μ (2.80).

Perylene. This was identified by its maxima at 245, 252, 385, 408, 426 (infl.), and 435 μ in the ultraviolet and by its fluorescence spectrum (Plate 4-1c), with

bands at 445, 475, and 502 μ , both in agreement with the literature⁴⁶.

11:12-Benzofluoranthene. This compound had a slightly higher R_f than 3:4-benzopyrene on acetylated paper. Ultraviolet absorption spectroscopy of an extract had maxima at 220, 236, 246 (infl.), 268, 283, 296, 308, 360, 378, and 401 μ in good agreement with the literature⁴⁶. (Fig. 4-3).

3:4-Benzopyrene. Identified by its absorption maxima at 226, 255, 266, 274, 284, 296, 330, 364, 384, and 404 μ (lit.⁸⁶), this was confirmed by its characteristic fluorescence spectrum with bands at 398, 404, 409, 417, 427, 456, and 485. (Plate 4-1d).

Pyrolysis of Indene at 700°.- Indene (93 g.) η_D^{14} 1.5676, which contained no impurities (as shown by gas-liquid chromatography) was pyrolysed at 700° under similar conditions as for tetralin. (Some blocking of the silica tube occurred near the outlet end, and it was found necessary to heat frequently the portion protruding from the furnace with a Bunsen burner). The solid yellow-brown tar (44 g.) resulting was collected, and another quantity (1 g.) was obtained by washing the

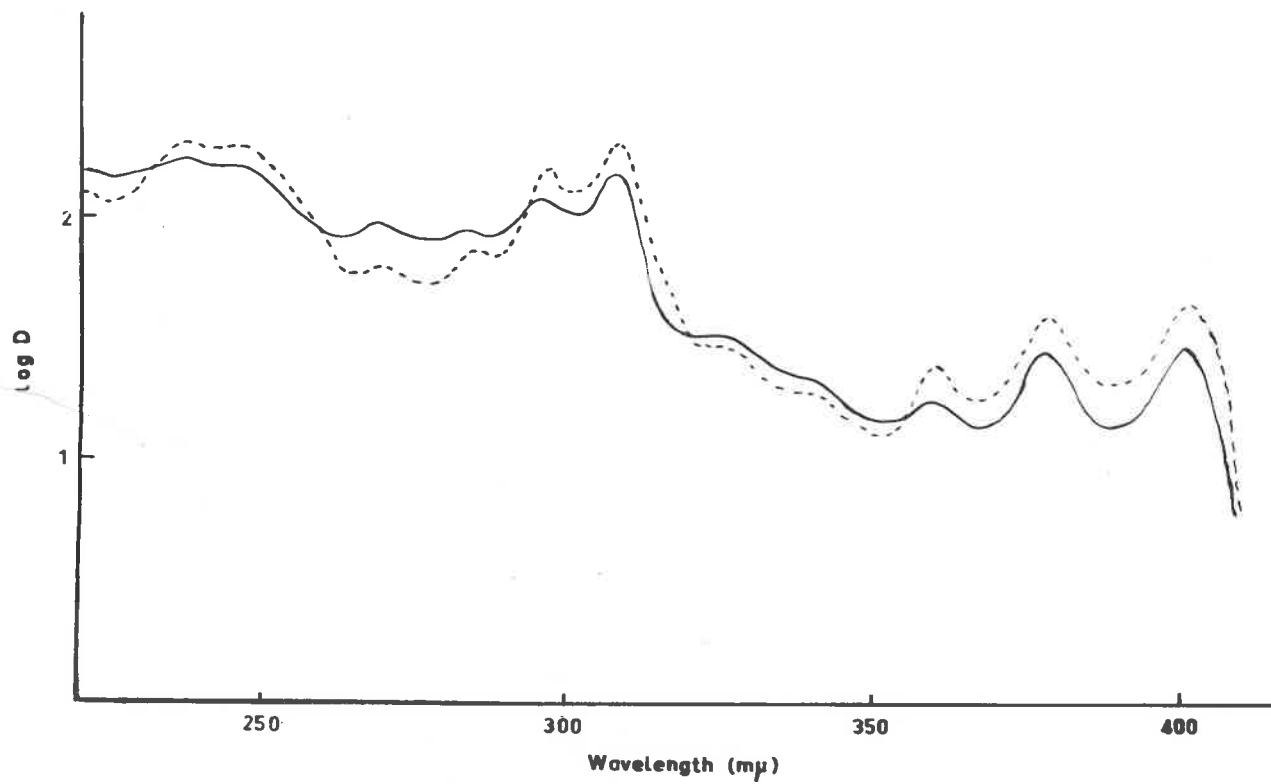

Fig. 4-3. 11:12-Benzofluoranthene from pyrolysis of tetralin
(—). Authentic (---).

pyrolysis tube with boiling chloroform and evaporating the solvent. A further trap, cooled in a dry-ice/ethanol mixture condensed lower boiling products (3 g.) (fraction a). The exit gases decolourised bromine water and permanganate solutions. Samples of the gases were examined by infrared spectroscopy.

Distillation of the tar (bath temperature up to $220^{\circ}/50$ mm.) removed the low boiling products and gave residue (b). Redistillation gave the following fractions: (c) b.p. $90^{\circ}/25$ mm. (3 g.); and (d) b.p. $95-105^{\circ}/30$ mm. (4 g.).

Analysis Techniques.- These were similar to those used for the analysis of the tetralin tar. Separation of the low boiling products was carried out by gas-liquid chromatography, which were then identified from their infrared spectra. However, fractions of higher molecular weight, after a preliminary separation on alumina, were chromatographed on a cellulose acetate column⁴⁴ (45 x 3 cm.). Portions of the fractions (10-200 mg.) from alumina chromatography were chromatographed in ethanol-benzene-water (17:4:1) and eluted with the same solvent. (Where chrysene was predominant in a fraction, its low solubility precluded larger amounts than 10-20 mg. being

used). The resulting fractions, after removal of the solvent, were weighed, and identified by their ultraviolet absorption spectra, and where practicable, by their melting points. These were confirmed in several cases by their fluorescence spectra. The percentage compositions were determined, where possible, gravimetrically, or where products were present in only minute amounts, and in overlapping fractions, (i.e. fractions containing more than one compound) from their ultraviolet spectra.

Examination of Fractions (a), (c), and (d).- These fractions were analysed by gas-liquid chromatography. Fraction (a) contained benzene (2.6 g.) and toluene (0.4 g.); fraction (c) unknown -X (0.6 g.), indene (2.3 g.) and naphthalene (0.1 g.); and fraction (d) unknown -X (0.52 g.), indene (0.81 g.) and naphthalene (2.6 g.). Both fractions (c) and (d) contained a small amount of material which had a retention time corresponding to styrene.

Examination of Residue.- The residue (fraction b) was extracted with benzene-hexane (1:4) in a Soxhlet apparatus. A black tar (0.5 g.) (fraction e) remained. The solvent was removed from the extracted product and a

slurry of the solid material (44.5 g.) in hexane, was placed on top of a large column of alumina (70 x 5 cm.). Development with hexane gave fractions 1 - 14; with benzene-hexane (1:2), fractions 15 - 27; and with benzene, fractions 28 - 31. The column was then stripped of all other material with ether, to give fraction (f) (10.5 g.) and a black tar (2 g.). (The latter was added to fraction e). The following fractions, which showed similar ultraviolet absorption spectra, were combined: i.e. fractions 1 - 5, (0.1 g.); 6 - 11, (0.11 g.); 12 - 14, (0.164 g.); 15 - 18 (1.22 g.); 19 - 21, (3.0 g.); and 22 - 30, (11.08 g.).

Fractions 1 - 5 contained naphthalene, while fractions 6 - 11 contained oily material which could not be identified. Chromatography on a cellulose acetate column of fractions 12 - 14 showed the presence of phenanthrene, anthracene, and fluorene. Similarly phenanthrene, anthracene, 3:4-benzophenanthrene, pyrene(?) and fluoranthene were identified from fractions 15 - 18, and 1:2-, 2:3-, and 3:4-benzofluorene, 1':2':3':4'-tetrahydro-3:4-benzopyrene(?), 3:4-benzophenanthrene, and 1:2-benzanthracene from fractions 19 - 21. Three recrystallisations from benzene of fractions 22 - 30 gave chrysene, while the mother liquors, by chromatography on

cellulose acetate, were found to contain (in the order of elution from the column), 2:3-, and 1:2-benzofluorene, 1:2-benzanthracene, an alkylchrysene, 10:11-, and 11:12-benzofluorene, chrysene, 3:4-benzofluoranthene, and 3:4-benzopyrene.

Fraction (f) was recrystallised four times (from benzene), and the product (3 g.), although still yellow, shown by chromatography on acetylated paper to be almost pure chrysene. The combined mother liquors were chromatographed in benzene on alumina. Elution with benzene-hexane (1:1) gave eleven fractions (each of 70 c.c.), and with benzene, three further fractions (each of 175 c.c.). The column was then stripped with ether to give a further black tar (5 g.) (fraction g). Chromatography of a portion of the first eleven fractions combined, on cellulose acetate showed the presence of 1:2-, and 2:3-benzofluorene, 1:2-benzanthracene, and chrysene. Similarly the latter three fractions were shown to be mainly chrysene, together with a small amount of a compound unknown -Y.

The picrates of fractions (e) and (g) were decomposed with dilute ammonium hydroxide. The process was repeated and the product chromatographed on acetylated paper. However, no further apparently pure products

could be detected by ultraviolet absorption spectroscopy.

Details of Identification.-- Methane and ethylene.

Samples of the exit gases were collected in a gas cell for infrared analysis. Methane was identified by its spectrum⁵⁰ in the 7.8-8.5 μ region (maxima at 7.62, 7.73, 7.77, 7.81, 7.86, 7.90, 8.00, 8.05, 8.10, 8.17, 8.24, and 8.30 μ), and ethylene by its spectrum⁵⁰ in the 10-11.5 μ region (maxima at 10.00, 10.11, 10.21, 10.31, 10.52, 10.75, 10.84, 10.94, 11.00, 11.09, 11.17, and 11.24 μ).

Benzene. Separated from toluene in fraction (a) by gas-liquid chromatography benzene was identified⁵⁰ by its retention time, and by its infrared maxima (examined as vapour) at 2.40, 3.23, 5.06, 5.48, 6.65, 6.71, 7.18, 9.51, 9.63, 9.74, 12.82, 14.55, and 14.90 μ .

Toluene. This was identified⁵⁰ by its retention time and confirmed by its infrared spectrum, which showed (liquid film) maxima at 2.16, 2.31, 2.34, 2.47, 2.61, 2.74, 3.29, 3.31, 3.43, 3.48, 3.67, 3.90, 4.17, 4.46, 4.64, 5.03, 5.11, 5.14, 5.34, 5.39, 5.50, 5.55, 5.76, 6.85, and 7.29 μ .

Styrene(?). A very small peak from gas-liquid chromatography of fraction (c) had a retention time

identical with that obtained for an authentic specimen.

Indene. Recovered in fractions (c) and (d) this was identified by its retention time. The infrared spectrum of a specimen collected was identical with that of authentic indene.

Naphthalene. Isolated from fractions (b), (c), and (d) this had m.p. and mixed m.p. $79.5-80^{\circ}$.

Unknown -X. One peak, with a small shoulder, obtained by gas-liquid chromatography of fractions (c) and (d) had a retention time almost identical with that of n-propylbenzene. However, its infrared spectrum, although showing bands at 4.99 , 5.04 , 5.19 , 5.40 , and 5.49μ , typical of a monosubstituted benzene derivative, could not be identified with any of the obvious monosubstituted benzenes of similar boiling point. A strong band at 4.40μ suggested a disubstituted acetylene derivative.

Phenanthrene. Isolated from fraction (b) this had m.p. $99-100^{\circ}$ and mixed m.p. $99.5-100^{\circ}$. Its identification was confirmed by its ultraviolet absorption spectrum⁴⁶ which had maxima at 221, 245 (infl.), 252, 276, 282, 295, 316, 324, 332, 339, and 346 m μ .

Fluorene. Some of the early fractions from chromatography on cellulose acetate of the phenanthrene fractions also showed maxima at 262 (infl.), 274 (infl.), 290, 294 (infl.), and 301 μ , suggesting the presence of fluorene⁸⁹.

Anthracene. The next fraction from the column, although contaminated with phenanthrene, showed maxima at 252, 340, 353 (infl.), 358, 372 (infl.), and 377 μ indicative of anthracene⁴⁶. This was confirmed by its fluorescence spectrum with bands at 403, 429, and 455 μ , (Plate 4-le) in agreement with the literature⁹⁰.

Fluoranthene. Isolated by chromatography of fractions 15 - 18 on cellulose acetate, this was identified by its ultraviolet absorption spectrum, with maxima at 230 (infl.), 236, 252, 262, 272, 276, 282, 287, 310, 321, 340, and 359 μ , (Fig. 4-4) in good agreement with the literature⁴⁶. This was confirmed by its fluorescence spectrum with diffuse bands at approximately 430-450, 465, 513, and 573 μ (Plate 4-1f).

3:4-Benzophenanthrene.- This was isolated from fractions 15 - 18 and 19 - 21, and had m.p. 66-67.5^o and mixed m.p. 66-67^o. Its ultraviolet absorption spectrum

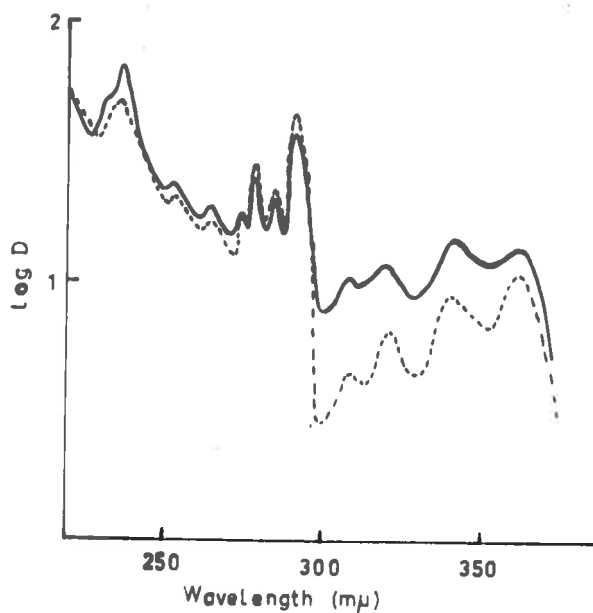

Fig. 4.4. Fluoranthene from indene pyrolysis (—).
Authentic (- - -).

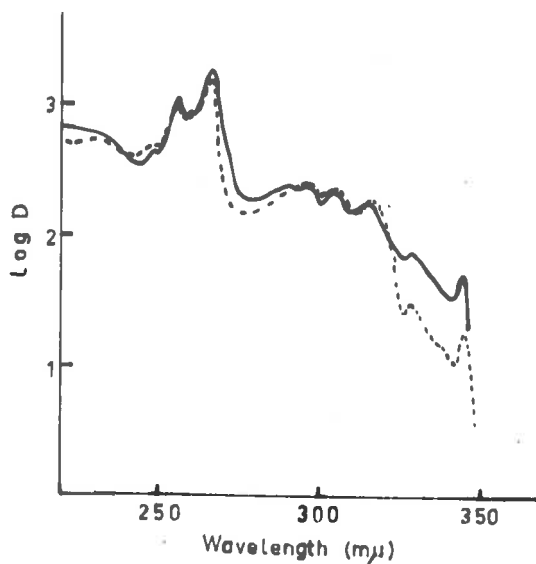

Fig. 4.5. 1:2-Benzofluorene from indene pyrolysis (—).
Authentic (- - -).

had maxima at 217, 227 (infl.), 229, 244 (infl.), 254 (infl.), 263 (infl.), 272, 282, 303, 316, 327, 354, and 372 μ in agreement with the literature⁴⁶.

Pyrene(?). Several of the fractions from chromatography on cellulose acetate of fractions 15 - 18 had absorption maxima at 319 and 335 μ suggesting the presence of pyrene⁴⁶. Its fluorescence spectrum, although diffuse, had the same bands as an authentic specimen (Plate 4*1g).

1:2-Benzofluorene. Some of the early fractions from chromatography of fractions 19 - 21, 22 - 30, and of fraction (f) on cellulose acetate, showed ultraviolet absorption maxima at 245, 254, 258, 263, 288, 294, 302, 315, 328, and 342 μ indicative of 1:2-benzofluorene⁸⁹. (Fig. 4*5).

2:3-Benzofluorene. This was identified from the same fractions by maxima⁶⁸ at 216, 255, 264, 274 (infl.), 285, 292 (infl.), 304, 313 (infl.), 317, 325, 333, and 340 μ . One specimen had m.p. 205-206^o and mixed m.p. 207-208^o. (lit.⁹¹ 208-209^o).

3:4-Benzofluorene. Some of the 1:2-, and 2:3-benzofluorene fractions from chromatography of fractions

19 - 21 on cellulose acetate, also had ultraviolet maxima at 230, 329, and 336 μ (Fig. 4.6), suggesting the presence of 3:4-benzofluorene (lit.⁶⁸ values are 230, 250, 268, 298, 312, 320, 328, and 336 μ).

1':2':3':4'-Tetrahydro-3:4-benzopyrene(?). One fraction of the above chromatogram could not be obtained in a pure state. It had maxima at 245, 266, 279, 303, 316, 330, 345, 358, 364 (infl.), 370, and 377 μ suggesting a substituted pyrene (Fig. 4.7). Literature⁹² values for 1':2':3':4'-tetrahydro-3:4-benzopyrene are 228, 239, 247, 258, 268, 280, 304, 316, 329, 346, 358, 370, and 378 μ .

1:2-Benzanthracene. Found in various fractions, this was identified by its m.p., ultraviolet⁴⁶ and fluorescence spectrum, and by its R_f on cellulose acetate. One specimen, following micro-sublimation onto a microscope cover-slip, had m.p. and mixed m.p. 158-159^o (Leitz hot-stage microscope) and light absorption maxima at 222, 238, 254 (infl.), 257, 268, 278, 288, 301, 314, 325, 340, 359, 374, and 384 μ .

Unknown -Y. An oily fraction (which may have been impure) obtained from chromatography of fraction (f) on

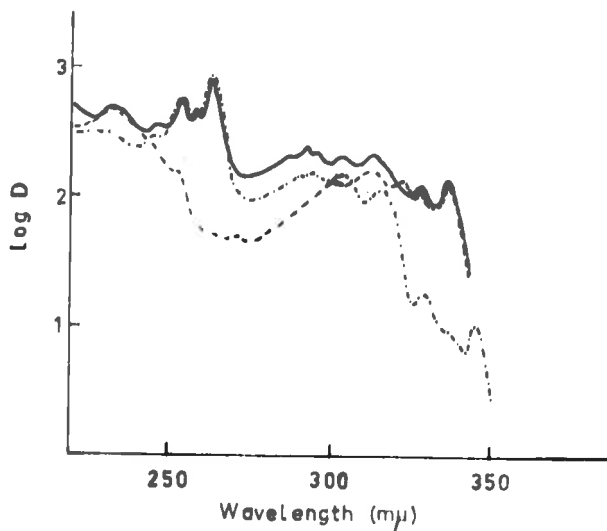

Fig. 4.6. Mixture of 3:4- and 1:2-Benzofluorene from indene pyrolysis (——). Authentic 3:4-benzofluorene (---) and 1:2-benzofluorene (-.-.).

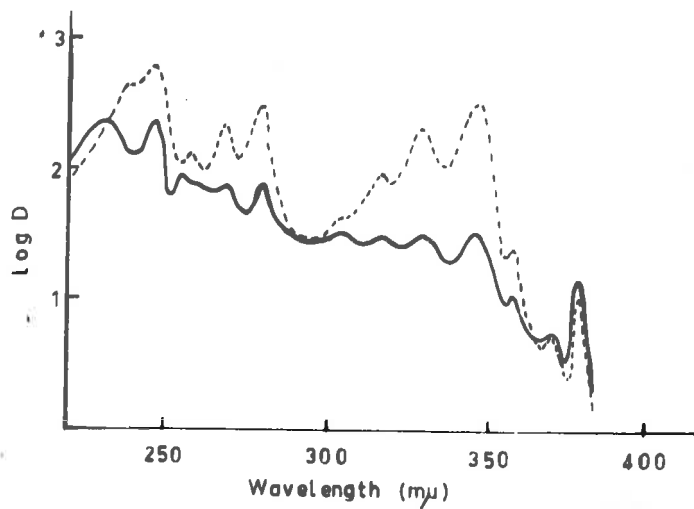

Fig. 4.7. 1':2':3':4'-Tetrahydro-3:4-benzopyrene(?) (——). Authentic (---).

cellulose acetate had a high R_f value. It showed absorption maxima at 247, 266 (infl.), 274, 281, 285, 303, 313, and 340 $m\mu$.

Alkylchrysene. Observed in fractions 22 - 30, its ultraviolet absorption spectrum had maxima at 260, 270, 282, 291, 296, 308, and 320 $m\mu$ suggesting an alkylchrysene.

Chrysene. A specimen was recrystallised twice from benzene. It had m.p. 251-252⁰, not depressed by admixture with an authentic sample. Its light absorption had maxima⁴⁶ at 220, 241, 258, 268, 283, 296, 307, 320, 343, and 361 $m\mu$.

10:11-Benzofluoranthene. A yellow fluorescent band on the cellulose acetate column by chromatography of fractions 22-30, had a R_f value slightly higher than chrysene. Its ultraviolet absorption spectrum had maxima at 292, 306, 317, 333, 364, 375, and 382 $m\mu$ (Fig. 4.8) in substantial agreement with the literature⁴⁶ for 10:11-benzofluoranthene.

11:12-Benzofluoranthene. One of the first of the above fractions containing 10:11-benzofluoranthene also

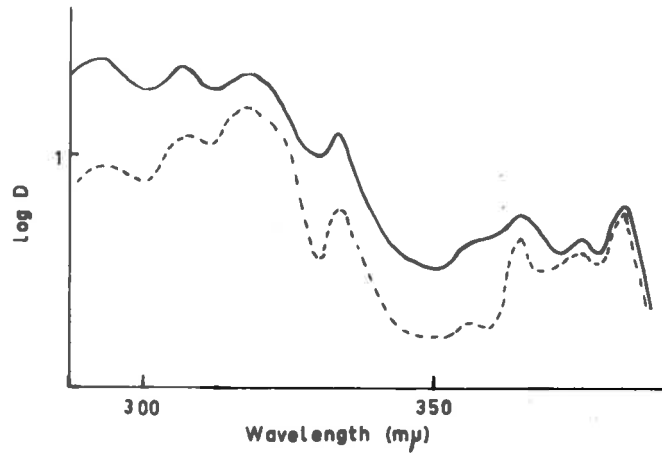

Fig. 4-8. 10:11-Benzofluoranthene from indene pyrolysis (—).
Authentic (- - -).

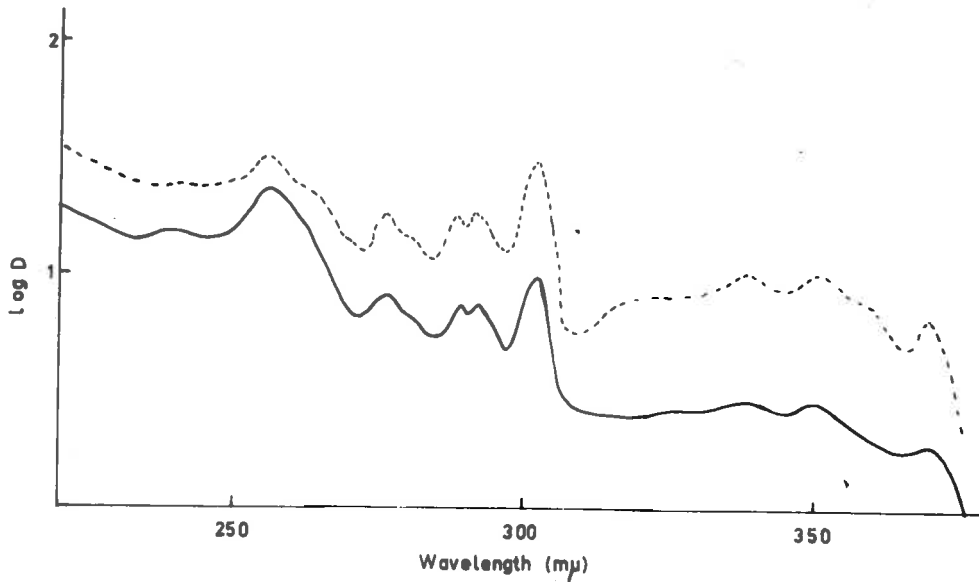

Fig. 4-9. 3:4-Benzofluoranthene from indene pyrolysis (—).
Authentic (- - -).

had maxima at 378 and 401 m μ in agreement with literature values for 11:12-benzofluoranthene in this region⁴⁶.

This was confirmed by its distinctive fluorescence spectrum which had bands at 409, 432, 467, and 500 m μ (Plate 4·lh) identical with those of an authentic specimen.

3:4-Benzofluoranthene. A blue fluorescent compound having a slightly higher R_f on cellulose acetate than 3:4-benzopyrene, had light absorption maxima at 239, 256, 276, 281 (infl.), 289, 292, 302, 338, 350, and 369 m μ indicative of 3:4-benzofluoranthene⁴⁶. (Fig. 4·9). Its R_f and fluorescence spectrum were identical with an authentic specimen.

3:4-Benzopyrene. Identified by its R_f on cellulose acetate, this had light absorption maxima at 226, 256, 265, 273, 284, 297, 331, 364, 381, 384, and 405 m μ in good agreement with the literature⁸⁸. The identification was confirmed by its fluorescence spectrum, with bands at 404, 409, 417, 427, 456, and 485 m μ .

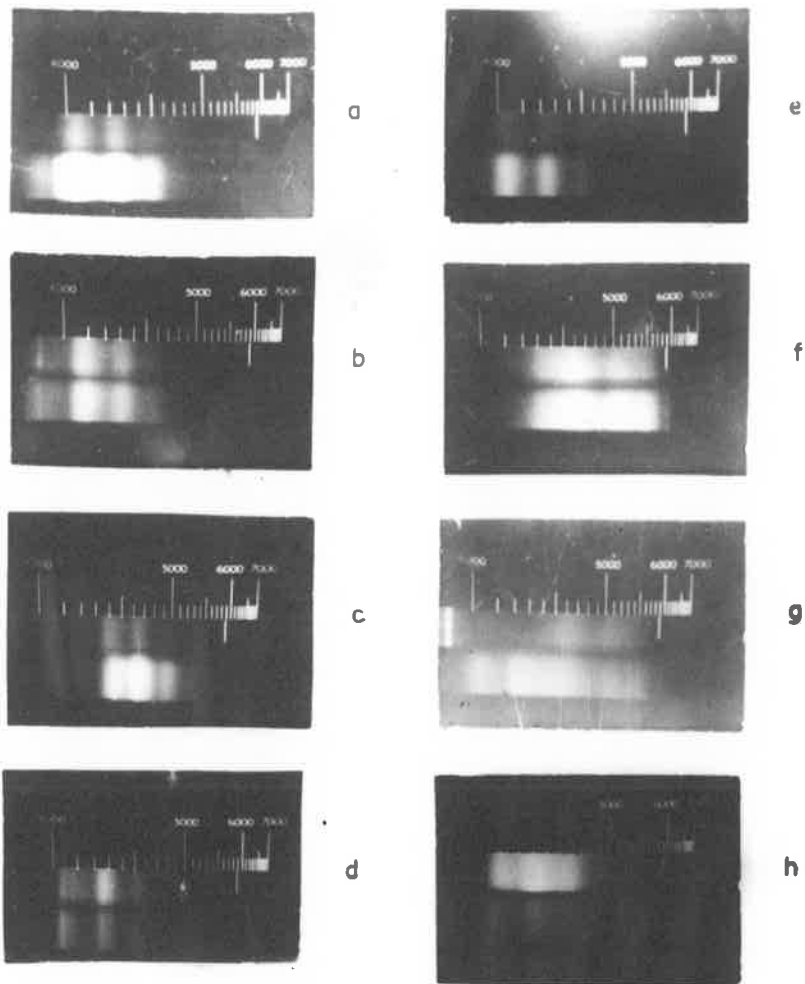

Plate 4.1. (a) Anthracene; (b) 1:2-benzanthracene; (c) perylene; (d) 3:4-benzopyrene from the tetralin pyrolysis; and (e) anthracene; (f) fluoranthene; (g) pyrene; (h) 11:12-benzofluoranthene from the indene pyrolysis (Upper spectra are authentic specimens).

REFERENCES.

1. Mantel and Hansen, Brennstoff Chem., 1954, 138.
2. Groll, Ind. Eng. Chem., 1933, 25, 784.
3. Weizmann, Bergmann, Huggett, Steiner, Sulzbacher,
Parker, Michaelis, Whincup, and Zimkin,
Ind. Eng. Chem., 1951, 43, 2312;
Weizmann, Bergmann, Boyd-Barrett, Steiner,
Sulzbacher, Holker, Mandel, Porges, and Rowley,
Ind. Eng. Chem., 1951, 43, 2318;
Weizmann, Bergmann, Huggett, Steiner, Sulzbacher,
Michaelis, Popper, Whincup, and Zimkin, Ind.
Eng. Chem., 1951, 43, 2322;
Weizmann, Henri, and Bergmann, Ind. Eng. Chem.,
1951, 43, 2325.
4. Hague and Wheeler, J. Chem. Soc., 1929, 378.
5. Wheeler and Wood, J. Chem. Soc., 1930, 1819.
6. Schneider and Frolich, Ind. Eng. Chem., 1931, 23,
1405.
7. Badger and Spotswood, unpublished.
8. Badger and BATTERY, J. Chem. Soc., 1958, 2458.
9. Badger and Spotswood, J. Chem. Soc., 1959, 1635.
10. Steiner, unpublished (see Ref. 3).

11. Zanetti and Egloff, Ind. Eng. Chem., 1917, 9, 350;
(see also Egloff, "Reactions of pure hydrocarbons",
Reinhold, 1937, p. 498).
12. Murphy and Duggan, J. Amer. Chem. Soc., 1949, 49,
3347.
13. Cook, Hewett, and Hieger, J. Chem. Soc., 1933, 395.
14. Goulden and Tipler, Brit. J. Cancer, 1949, 3, 157;
Passey, Brit. Med. J., 1922, 11, 1112.
15. Sulman and Sulman, Cancer Res., 1946, 6, 366;
Beráňková and Sůla, Časopis Lékařů, Českých, 1953,
92, 195; Chem. Abs., 1955, 49, 592.
16. Cooper, Chem. and Ind., 1953, 1364;
Cooper and Lindsey, Chem. and Ind., 1953, 1177;
1260;
Clemo, Chem. and Ind., 1953, 557; 1955, 38;
Waller, Brit. J. Cancer, 1952, 6, 8;
Leiter, Shimkin, and Shear, J. Nat. Cancer Inst.,
1942, 3, 155;
Shore and Katz, Analyt. Chem., 1956, 28, 1399.
17. Falk, Steiner, Goldfein, Breslow, and Hykes, Cancer
Res., 1951, 11, 318.
18. Falk and Steiner, Cancer Res., 1952, 12, 30;
von Haam and Mallette, Arch. Industr. Hyg., 1952,
6, 237.

19. Kotin, Cancer Res., 1956, 16, 375.
20. Gilbert and Lindsey, Chem. and Ind., 1956, 927.
21. Hougen, Chem. and Ind., 1954, 192.
22. Campbell and Lindsey, Chem. and Ind., 1955, 64;
1957, 951.
23. Campbell and Lindsey, Brit. J. Cancer, 1956, 10, 649.
24. Cooper, Lindsey, and Waller, Chem. and Ind., 1953,
1205; 1954, 1418;
Gilbert and Lindsey, Brit. J. Cancer, 1956, 10, 642;
Bonnet and Neukomm, Helv. Chim. Acta., 1956, 39,
1724;
Patton and Touey, Analyt. Chem., 1956, 28, 1685;
Philippe and Hobbs, Analyt. Chem., 1956, 28, 2002;
Gilbert and Lindsey, Brit. J. Cancer, 1956, 10, 646;
25. Kennaway, Brit. Med. J., 1925, 11, 1.
26. Berenblum and Schoental, Brit. J. exp. Path., 1943,
24, 232.
27. Kennaway and Sampson, J. Path. Bact., 1928, 31, 609;
Falk, Goldfein, and Steiner, Cancer Res., 1949, 9,
438.
28. Kennaway, J. Path. Bact., 1924, 27, 233.
29. Lam, Acta Path. Microbiol. Scand., 1956, 39, 198.
30. Lam, Acta Path. Microbiol. Scand., 1955, 37, 421;
1956, 39, 207.

31. Badger and Napier, unpublished.
32. Berthelot, Ann. Chim., 1866, 9, 445;
Zelinsky, Compt. rend., 1923, 177, 882; Ber.,
1924, 57, 264.
33. Fishel and Haskins, Ind. Eng. Chem., 1949, 41, 1374.
34. Beilstein, Suppl. Vol. V, 1930, 63.
35. Schroeter, Ber., 1924, 57, 1990.
36. Kennaway, Biochem. J., 1930, 24, 497;
Hieger, Biochem. J., 1930, 24, 505.
37. Cook and Hewett, J. Chem. Soc., 1933, 398; cf.
Grove, J. Chem. Soc., 1953, 483.
38. Rozenberg, Doklady Akad. Nauk S.S.S.R., 1950, 73,
719; see also, Hansch, Chem. Revs., 1953, 53,
353.
39. Mackinnon and Ritchie, J. Chem. Soc., 1957, 2564.
40. Balandin, Marukyan and Tolstopyatova, J. Appl. Chem.
(U.S.S.R.), 1946, 19, 1079.
41. Badger, Buttery, Kimber, Lewis, Moritz, and Napier,
J. Chem. Soc., 1958, 2449.
42. Napier and Rodda, Chem. and Ind., 1958, 1319.
43. Spotswood, J. Chromatography, 1959, 2, 90.
44. Spotswood, J. Chromatography, 1959, in the press.
45. Grove, J. Chem. Soc., 1953, 483.

46. Clar, "Aromatische Kohlenwasserstoffe", 2nd. edit., Springer, Berlin, 1952.
47. Mayneord and Roe, Proc. Roy. Soc., 1935, A, 152, 323.
48. Clar, Spectrochim. Acta, 1950, 4, 119.
49. Berenblum, Nature, 1945, 156, 601.
50. American Petroleum Institute Research Project 44, Infrared Spectral Data.
51. Braun and Kirschbaum, Ber., 1921, 54, 616.
52. Dannley and Zaremsky, J. Amer. Chem. Soc., 1955, 77, 1588.
53. Levy and Szwarc, J. Amer. Chem. Soc., 1953, 77, 1949.
54. Adkins, Wojcik, and Covert, J. Amer. Chem. Soc., 1933, 55, 1669.
55. Braun and Zobel, Ber., 1923, 56, 2139.
56. Poos, Arth, Beyler, and Sarett, J. Amer. Chem. Soc., 1953, 75, 422.
57. Field and Grundy, J. Chem. Soc., 1955, 1110.
58. Bouveault, Bull. Soc. Chim., 1908, iv, 3, 123.
59. Braun and Kruber, Ber., 1912, 45, 398.
60. Brown and Rao, J. Amer. Chem. Soc., 1958, 80, 5377.
61. Boer and Duinker, Rec. Trav. Chim., 1958, 77, 346.
62. Kindler, Annalen, 1939, 452, 90.
63. Clutterbuck and Cohen, J. Chem. Soc., 1923, 123, 2507.
64. Braun, Ber., 1911, 44, 2867.

65. Organic Reactions, 1954, 8, 285, 286.
66. Gillespie, Jefferies, Macbeth, and Thompson, J. Chem. Soc., 1955, 655.
67. Bachmann and Wilds, J. Amer. Chem. Soc., 1938, 60, 624.
68. Friedel and Orchin, "Ultraviolet Spectra of Aromatic Compounds".
69. Hiickel, Annalen, 1925, 441, 21.
70. Elsevier's Encyclopedia of Organic Chemistry, Series III, 14.
71. Cason, J. Amer. Chem. Soc., 1946, 68, 2078.
72. Graebe, Ber., 1872, 5, 677.
73. Jones, J. Chem. Soc., 1915, 107, 1582.
74. Sundgren, Ann. Combustibles Liquides, 1930, 5, 35.
75. Meyer, Angew. Chem., 1924, 37, 796.
76. Steacie, "Atomic and Free Radical Reactions", Reinhold, New York, 1954;
Braude and Nachod, "Determination of Organic Structures by Physical Methods", Academic press, New York, 1955.
77. Orchin and Reggel, J. Amer. Chem. Soc., 1947, 69, 505.
78. Porter and Wright, Trans. Farad. Soc., 1955, 51, 1469.
79. Spilker, Ber., 1893, 26, 1538.
80. Hansch, Chem. Revs., 1953, 53, 353.

81. Pullman and Berthier, Bull. Soc. Chim., 1948, 15,
551.
82. Walling, "Free Radicals in Solution", Wiley, New
York, 1957.
83. Baker, McOmie and Norman, Chem. and Ind., 1950, 77.
84. Stobbe and Farber, Ber., 1924, 57, 1838; (see also
Egloff, "Reactions of Pure Hydrocarbons",
Reinhold, New York, 1937).
85. Schroeter, Annalen, 1921, 426, 1.
86. Auvers, Ber., 1913, 46, 2988.
87. Fieser and Hershberg, J. Amer. Chem. Soc., 1938,
60, 940.
88. Clar, Ber., 1936, 69, 1671.
89. Mayneord and Roe, Proc. Roy. Soc., London, 1937, A,
158, 634.
90. Millar and Baumann, Cancer Res., 1943, 3, 217.
91. Kruber, Ber., 1937, 70, 1556.
92. Kon and Roe, J. Chem. Soc., 1945, 143.

SUMMARY

Some of the problems associated with the mode of formation of aromatic hydrocarbons at high temperature have been investigated. A feasible route to the formation of 3:4-benzopyrene in tars involving, two, four, six, ten, and twenty carbon units has been taken as a working hypothesis. This mechanism presupposes that 3:4-benzopyrene may be found by pyrolysis of any of these supposed intermediate compounds. The pyrolysis of 1-4'-phenylbutylnaphthalene (and related compounds), tetralin, and indene have been shown to contain 3:4-benzopyrene (together with twenty-five to thirty other compounds in the case of tetralin and indene), and a fraction of "Schroeter Tar", known to be strongly carcinogenic, has now been found to contain some 4% of 3:4-benzopyrene. These experiments, together with other very recent results in this field, have confirmed the suggestion that the most important reactions in pyrolytic synthesis involve cracking (with the formation of free radicals which then undergo further reaction), dehydrogenations, and cyclohydrogenations. However, the suggestion that diene synthesis also plays an important part has been shown to be most unlikely.

Badger, G. M., Buttery, R. G., Kimber, R. W. L., Lewis, G. E., Moritz, A. G., & Napier, I. M. (1958). The formation of aromatic hydrocarbons at high temperatures. Part I. Introduction. *Journal of the Chemical Society*, (0), 2449-2452.

NOTE:

This publication is included in the print copy
of the thesis held in the University of Adelaide Library.

It is also available online to authorised users at:

<https://doi.org/10.1039/JR9580002449>

Badger, G. M., & Kimber, R. W. L. (1958). The formation of aromatic hydrocarbons at high temperatures. Part II. An examination of "Schroeter tar." *Journal of the Chemical Society*, (0), 2453-2454.

NOTE:

This publication is included in the print copy of the thesis held in the University of Adelaide Library.

It is also available online to authorised users at:

<https://doi.org/10.1039/JR9580002453>

Badger, G. M., & Kimber, R. W. L. (1958). The formation of aromatic hydrocarbons at high temperatures. Part III. The pyrolysis of 1-4'-phenylbutylnaphthalene. *Journal of the Chemical Society*, (0), 2455-2458.

NOTE:

This publication is included in the print copy of the thesis held in the University of Adelaide Library.

It is also available online to authorised users at:

<https://doi.org/10.1039/JR9580002455>

Badger, G. M., Jefferies, P. R., & Kimber, R. W. L. (1957). The synthesis of polycyclic aromatic hydrocarbons. Part I. A synthesis of optically active 9 : 10-dihydrodinaphtho(2' : 3'3 : 4)-(2'' : 3'' -5 : 6)phenanthrene, and a new synthesis of pentaphene. *Journal of the Chemical Society*, (0), 1837-1841.

NOTE:

This publication is included in the print copy of the thesis held in the University of Adelaide Library.

It is also available online to authorised users at:

<https://doi.org/10.1039/JR9570001837>