

PUBLICATIONS SUBMITTED FOR THE DEGREE OF

DOCTOR OF SCIENCE

IN THE UNIVERSITY OF ADELAIDE

BY I.S. DE LA LANDE

B.Sc. (Melb, 1945)

M.Sc. (Melb, 1947)

Ph.D. (Melb, 1958)

*accepted for publication*

APRIL 1990

## PREFACE

The thesis is presented in two volumes of publications between 1948 and 1990.

Volume I focuses on the control of vascular sensitivity to catecholamines. It is divided into four sections, namely

- I. Early studies on the human.
- II. Development of the perfused artery of the rabbit ear as a vascular model.
- III. Factors controlling diffusion of catecholamines to receptors in vascular smooth muscle. This is the major study.
- IV. Interactions with other vasoactive substances, in particular acetylcholine, prostaglandins and serotonin.

Volume 2 focuses on tissues other than blood vessels; Section V is the main study.

- V. Noradrenaline disposition in reproductive and connective tissue.
- VI. Methodological and related aspects.
- VII. Aminergic mechanisms in brain, heart and gut.
- VIII. Pharmacology of natural products.

Except in Section II, papers are presented in order of publication. The numbering of the papers is the same as is shown in the complete list of publications at the beginning of Volume I. Three abstracts (numbered 1A, 2A and 3A) are interleaved at appropriate places in Volume I and a fourth (4A) in Volume II, Section 5. They are included because they contain relevant data which have not appeared as a major paper.

The two volumes contain all my major publications, but it is pointed out that those in Section 7 are mainly early publications whose themes are not very relevant to those of the preceding sections. Even more distant is Section VIII.

At the beginning of Volume I, there is a brief overview of the research. The number of the paper to which reference is made is shown in brackets. The overview includes some explanatory figures, taken from from presentations at meetings.

## PUBLICATIONS

(Excluding abstracts and abstract-type proceedings)

1. de la Lande, I.S. The alkaloids of *Cryptocarya pleurosperma*. Aust. J. Exp. Biol. Med. Sci., 26:181, 1948.
2. Shaw, F.H., de la Lande, I.S. The alkaloids of *Strychnos lucida*. Aust. J. Exp. Biol. Med. Sci., 26:199, 1948.
3. de la Lande, I.S., Bentley, G.A. The action of morphine and antagonists of the narcotic action of morphine on acetyl choline synthesis in brain. Aust. J. Exp. Biol. Med. Sci., 33:555, 1955.
5. de la Lande, I.S., Parks, V.J., Sandison, A.G., Skinner, S.L., Whelan, R.F. The peripheral dilator action of reserpine in man. Aust. J. Exp. Biol. Med. Sci., 38:313-320, 1960.
6. de la Lande, I.S., Manson, J., Parks V.J., Sandison, A.G., Skinner, S.L., Whelan, R.F. The local metabolic action of adrenaline on skeletal muscle in man. J. Physiol, 157:177, 1961.
7. Lykke, A.W.J., de la Lande, I.S. Carcinoid syndrome resulting from a malignant argentaffinoma in in Meckel's diverticulum. Med. J. Aust., 1:125, 1961.
8. de la Lande, I.S., Tyler, M.J., Pridmore, B.R. Pharmacology of the heart of *Tiliqua (Trachysaurus) rugosa* (the Sleepy Lizard). Aust. J. Exp. Biol. Med. Sci., 40:129-135, 1962.
9. de la Lande, I.S., Whelan, R.F. Role of lactic acid in the vasodilator action of adrenaline in the human limb. J. Physiol., 162:151-154, 1962.
10. de la Lande, I.S., Porter, R.B., The actions of tacrine and amiphenazole on acetylcholine metabolism in the guinea pig ileum. Aust. J. Exp. Biol. Med. Sci., 41:149-162, 1963.
11. Whelan, R.F., de la Lande, I.S. Action of adrenaline on limb blood vessels. Br. Med. Bull., 125-131, 1963.
12. de la Lande, I.S., Hodge, R.L., Reilly, P.L., Thomas, D.W. Iontophoresis of guanethidine in man. Aust. J. Exp. Biol. Med. Sci., 42:1, 1964.
13. de la Lande, Thomas, D.W., Tyler, M.J. Pharmacological analysis of the venom of the "Bulldog" and *Myrmecia forficata*. In "Recent Advances in the Pharmacology of Toxins." Proceedings of the Second International Pharmacological Meeting, Prague, 20-23 August, 1965. Czechoslovak Medical Press, Praha, 1965.
14. de la Lande, I.S., Rand, M.J. A simple isolated nerve-blood vessel preparation. Aust. J. Exp. Biol. Med. Sci., 44:205, 1965.
15. de la Lande, I.S., Harvey, J.A. A new and sensitive bioassay for catecholamines. J. Pharm. Pharmac. 17:589, 1965.
16. Cooper, C.J., de la Lande, I.S., Tyler, M.J. The catecholamines in the lizard heart. Aust. J. Exp. Biol. Med. Sci., 344:205, 1966.

17. de la Lande, I.S., Cannell V.A., Waterson, J.G. The interaction of serotonin and noradrenaline in the perfused artery.
18. de la Lande, I.S., Glover, W.E., The limit of sensitivity of bio-assay of catecholamines on the perfused arterial segment. *J. Pharm. Pharmac.* 18:324, 1966.
19. de la Lande, I.S., Lewis, J.C. Constituents of the venom of the Australian bull ant, *Myrmecia pyriformis*. *Mem. Inst. Butantan Simp. Internac.*, 33:951-956, 1966.
20. de la Lande, I.S., Glover, W.E., Head, R. The use of the rabbit ear artery in bioassay of catecholamines in urine. *J. Pharm. Pharmac.*, 19:674-681, 1967.
21. de la Lande, I.S., Frewin, D., Waterson, J.G. The influence of sympathetic innervation on vascular sensitivity to noradrenaline. *Br. J. Pharmac. Chemother.*, 31:82-93, 1967.
22. de la Lande, I.S., Waterson, J.G. Vascular effects of thiopentone and methohexitone in the rabbit ear. *J. Oral Ther. Pharmac.*, 462-467, 1967.
23. de la Lande, I.S., Head, R.J. The catecholamines in the central artery of the rabbit ear. *Aust. J. Exp. Biol. Med. Sci.*, 45:707-710, 1967.
24. de la Lande, I.S., Porter, R.B. Factors influencing the action of morphine acetylcholine release in the guinea-pig intestine. *Br. J. Pharmac. Chemother.*, 29:158-167, 1967.
25. de la Lande, I.S., Frewin, D., Waterson, J., Cannell, V. Factors influencing supersensitivity to noradrenaline in the isolated perfused artery; comparative effects of cocaine, denervation and serotonin. *Circ Res*, 21 (Suppl 3):177-181, 1967.
26. de la Lande, I.S., Waterson, J.G. Site of action of cocaine on the perfused artery. *Nature*, 214-313, 1967.
27. Waterson, J.G., de la Lande, I.S. Function of sympathetic nerves in blood vessels. *Ann Aust Coll Dent Surg.*, 1:60-69, 1967.
28. Lewis, J.C., de la Lande, I.S. Pharmacological and enzymic constituents of the venom of an Australian 'Bulldog' ant, *Myrmecia pyriformis*. *Toxicon*, 4:225-234, 1967.
29. de la Lande, I.S., Waterson, J.G. Modification of autofluorescence in the formaldehyde-treated rabbit ear artery by Evans blue. *J. Histochem. Cytochem.*, 16:281, 1968.
30. de la Lande, Waterson, J.G. The action of tyramine on the rabbit ear artery. *Br. J. Pharmac. Chemother.*, 34:8-18, 1968.
31. Lewis, J.C., Day, A.J., de la Lande, I.S. Phospholipase A in the venom of *Myrmecia pyriformis* (an Australian bulldog ant). *Toxicon*, 6:109-112, 1968.
32. de la Lande, I.S., Paton, W.D.M., Waud, B. Output of sympathetic transmitter in the isolated rabbit ear. *Aust. J. Exp. Biol. Med. Sci.*, 46:727-738, 1968.

33. de la Lande, I.S., Waterson, J.G. A comparison of the pharmacology of the isolated rabbit ear and its central artery. *Aust. J. Exp. Biol. Med. Sci.*, 46:739-745, 1968.
34. Slavotinek, A., de la Lande, I.S., Head, R. Medullary thyroid carcinomas with bilateral pheochromocytomas. *Aust. Ann. Med.*, 17:320-326, 1968.
35. Waterson, J.G., Hume, W.R., de la Lande, I.S. The distribution of cholinesterase in the rabbit ear artery. *J. Histochem. Cytochem.*, 18:211-216, 1970.
36. de la Lande, I.S., Hodge, R.L., Lazner, M., Jellett, L.B. Pharmacological implications of the fate of noradrenaline in the artery wall. *Circ. Res.*, 27 (Suppl 2):41-48, 1970.
37. de la Lande, I.S., Hill, B., Jellett, L.B., McNeil, J. The role of monoamine oxidase in the response of the rabbit ear to tyramine. *Br. J. Pharmacol.*, 4):249-256, 1970.
38. de la Lande, I.S., Jellett, L.B. Relationship between the roles of monoamine oxidase and sympathetic nerves in the vasoconstrictor response to norepinephrine. *J. Pharmac. Exp. Ther.*, 180:47-55, 1972.
39. Hume, R., de la Lande, I.S., Waterson, J.G. Effect of acetyl choline on the response of the isolated rabbit ear artery to stimulation of the perivascular sympathetic nerves. *Eur. J. Pharmacol.*, 17:227-233, 1972.
40. de la Lande, I.S., Johnson, S.M. Evidence of inactivation of noradrenaline by extraneuronal monoamine oxidase. *Aust. J. Exp. Biol. Med. Sci.*, 50:119-121, 1972.
41. Fleming, W.W., Westfall, D.P., de la Lande, I.S., Jellett, L.B. Log-normal distribution of equieffective doses of norepinephrine and acetylcholine in several tissues. *J. Pharmac. Exp. Ther.*, 181:339-345, 1972.
42. de la Lande, I.S., Jellett, L.B., Lazner, M.A., Parker, D.A.S., Waterson, J.G. Histochemical analysis of the diffusion of noradrenaline across the artery wall. *Aust. J. Exp. Biol. Med. Sci.*, 52:193-200, 1974.
43. Waterson, J.G., de la Lande, I.S. The influence of replacing sodium by potassium ions on uptake of noradrenaline in the rabbit ear artery. *Aust. J. Exp. Biol. Med. Sci.*, 52:210-205, 1974.
44. de la Lande, I.S., Harvey, J.A., Holt, S. Response of the rabbit coronary arteries to autonomic agents. *Blood Vessels*, 11:319-337, 1974.
45. Lazner, M.A., de la Lande, I.S. Comparative potencies of dopamine and noradrenaline on the rabbit ear artery. *J. Pharm. Pharmacol.*, 26:62, 1974.
46. Wanstall, J.C., de la Lande, I.S. Fractionation of bulldog ant venom. *Toxicon*, 12:649-655, 1974.
47. de la Lande I.S., Hall, R.C., Kennedy, J.A., Higgins, G.D. Prostaglandins, antipyretic analgesics and adrenergic stimuli on the isolated artery. *Eur J Pharmacol* 30:319-327, 1975.
48. de la Lande, I.S. Adrenergic mechanisms in the rabbit ear artery. "Review". *Blood Vessels*, 12:137-160, 1975.
49. Head, R.J., Johnson, S.M., Berry, D., de la Lande, I.S. Denervation and O-methylation of noradrenaline in the rabbit ear artery. *Clin. Exp. Pharmac. Physiol.*, Suppl. 2:39-42, 1975.

50. de la Lande, I.S. The Safety of Marihuana: A Viewpoint. J. Aust. & N.Z. Student Services Assoc., 3:5-11, 1976.
51. Head, R.J., Crabb, G.A., de la Lande, I.S., Frewin, D.B. Semi-automated catecholamine assay. Aust. J. Exp. Biol. Med. Sci., 55:213-23, 1977.
52. Head, R.J., Stitzel, R.M., de la Lande, I.S., Johnson, S.M. Effect of chronic denervation on the activities of monamine oxidase and catechol-O-methyl transferase on the contents of noradrenaline and adenosine triphosphate in the rabbit ear artery. Blood Vessels, 14:229-239, 1977.
53. Foldes, A., Head, R.J., de la Lande, I.S. Endogenous and exogenous histamine in rabbit thoracic aorta. Aust. J. Exp. Biol. Med. Sci., 55:89-102, 1977.
54. Head, R.J., Kennedy, J.A., de la Lande, I.S., Crabb, G.A. Thin-layer chromatographic separation of the 3-O-methylated metabolites of noradrenaline. J. Chromatogr. Sci., 16:82-85, 1978.
55. Johnson, S.M., de la Lande, I.S. Action of deoxycorticosterone acetate on the central artery of the rabbit ear. Blood Vessels, 15:23-246, 1978.
56. Head, R.J., de la Lande, I.S., Irvine, R.J., Johnson, S.M. Uptake and O-methylation of isoprenaline in the rabbit ear artery. Blood Vessels, 17:229-245, 1980.
57. de la Lande, I.S., Venning, M. Arterial extra- and intralumen responses. In "Vascular Neuroeffector Mechanisms," (Ed. J.A. Bevan), pp. 35-36, Raven Press, New York, 1980.
58. de la Lande, I.S., Parker, D.A.S., Morris, R., Irvine, R., Graefe, K.H. Noradrenaline diffusion across the artery. In "Vascular Neuro-effector Mechanisms," (Ed. J.A. Bevan), pp. 148-160, Raven Press, New York, 1980.
59. de la Lande, I.S., This Week's Citation Classic. (de la Lande, I.S. & Rand, M.J. A simple isolated nerve-blood vessel preparation, Aust. J. Exp. Biol. Med. Sci. 43:639-56, 1965), Current Contents, 22:16, 1980.
60. de la Lande, I.S. Inactivation and metabolism of catecholamines. Proceedings of the Fourth International Meeting on Adrenergic Mechanisms, pp. 75-91, Porto University, 1981.
61. De La Lande, I.S., O'Brien, P. E. , Shearman D J C, Taylor P, Tyler M J. On the possible role of prostaglandin E<sub>2</sub> in intestinal steals in the gastric brooding frog *Rheobatrachus silus*. Aust. J. Exp. Biol. Med. Sci., 62, 317-323, 1984.
62. Head, R.J., Cassis, L.A., Barone, S., Stitzel, R.E., de la Lande, I.S. Neuronal deamination of endogenous and exogenous noradrenaline in the mesenteric artery of the spontaneously hypertensive rat. J. Pharm. Pharmacol., 36, 382-385, 1984.
63. Kennedy, J.A., de la Lande, I.S., Morris, R.G. Effect of ovarian steroids on the metabolism of noradrenaline in rabbit uterus. Naunyn-Schmiedeberg's Arch. Pharmacol. 326, 143-147, 1984.
64. Kennedy, J.A., de la Lande, I.S. The effect of pregnancy on the metabolism of noradrenaline in reproductive organs of the rabbit. Naunyn-Schmiedeberg's Arch. Pharmacol. 326, 132-142, 1984.

65. Minson, J.B., de la Lande, I.S. Metabolism of exogenous noradrenaline in slices of hypothalamus and caudate nucleus of the brush-tail possum, *Trichosurus vulpecula*. *Aust.J.Exp.Biol.Med.Sci.*, 62, 341-354, 1984.
66. Minson, J.B., de la Lande, I.S. Factors influencing the release of noradrenaline from hypothalamic slices of the possum, *Trichosurus vulpecula*. *Aust.J.Exp.Biol.Med.Sci.*, 62, 341-354, 1984.
67. Venning, M.G., de la Lande, I.S. Effects of uptake and surface of entry on the responses of the rat caudal artery to noradrenaline, adrenaline and methoxamine. *Blood Vessels*, 21, 149-155, 1984.
68. Head, R.J., Irvine, R.J., Barone, S., Stitzel, R. E., de la Lande, I.S. Nonintracellular, cell-associated O-methylation of isoprotenerol in the isolated rabbit thoracic aorta. *J. Pharmac.Exp.Therap.*, 234, 184-189, 1985.
69. Parker, D.A.S., de la Lande, I.S., Thompson, J.A., Parker, I. Effect of prazosin on the efflux of  $^3\text{H}$ -norepinephrine and metabolites from the intima and adventitia of the rabbit ear artery. *Blood Vessels*, 22, 74-83, 1985.
70. Venning, M.G., de la Lande, I.S. Effect of inhibition of neuronal uptake on the flux of extraluminal noradrenaline into the lumen of the rat tail artery. *Blood Vessels*, 22, 244-246, 1985.
71. Parker, I., Parker, D.A.S., de la Lande, I.S., Thompson, J.A., Procter C, Marino V. Role of sympathetic nerves in the metabolism of exogenous noradrenaline in rabbit gingival tissue and ear artery. *Aust.J.Exp.Biol. Med.Sci.*, 64, 505-516, 1986.
72. Parker, I., Parker, D.A.S., de la Lande, I.S. Catecholamine Contents of Rabbit Gingiva and Dental Pulp. *Aust.J.Exp.Biol.Med.Sci.*, 64, 465-469, 1986.
73. Kennedy, J.A., de la Lande, I.S. Effect of progesterone on the metabolism of noradrenaline in rabbit uterine endometrium and myometrium. *Naunyn-Schmiedeberg's Arch. Pharmacol.* 333, 368-376, 1986.
74. Parker, D.A.S., de la Lande, I.S., Proctor, C., Marino, V., Lam, N.X., Parker, I. Cocaine-sensitive O-methylation of noradrenaline in dental pulp of the rabbit: comparison with rabbit ear artery. *Naunyn-Schmiedeberg's Arch. Pharmacol.* 335, 32-39, 1987.
75. Kennedy, J.A., de la Lande, I.S. Characteristics of cocaine-sensitive accumulation and O-methylation of  $^3\text{H}$ -(-)-noradrenaline by rabbit endometrium. *Naunyn-Schmiedeberg's Arch. Pharmacol.* 336, 148-154, 1987.
76. de la Lande, I.S., Parker D.A.S., Procter, C.H., Marino, V., Mackay-Sim, A. Cocaine inhibits extraneuronal O-methylation of exogenous norepinephrine in nasal and oral tissues of the rabbit. *Life Sciences*, 41, 22:2463-2468, 1987.
77. de la Lande, I.S., Venning, M.G., Morris, R.G. Vascular Tone and Diffusion of Norepinephrine. In "Vasodilatation; vascular smooth muscle, peptides, autonomic nerves and endothelium" P.M. VanHoutte (ed.), Raven Press, New York, 161-165, 1988.
78. Morris, R.G., Venning, M.G., de la Lande, I.S. Influence of uptake<sub>1</sub> and uptake<sub>2</sub> on the relationship between diffusion and metabolism of noradrenaline in the perfused rabbit ear artery. *Blood Vessels*, 25, 217-231, 1988.

79. Venning, M.G., de la Lande, I.S., Morris, R.G. Metabolism of exogenous noradrenaline in constricted and distended rabbit ear arteries. *Blood Vessels*, 25, 185-198, 1988.
80. Venning, M.G., de la Lande, I.S. Role of sympathetic nerves in disposition and metabolism of intraluminal and extraluminal noradrenaline in the rabbit ear artery. *Blood Vessels*, 25, 232-239, 1988.
81. Kennedy, J.A., de la Lande, I.S. Catecholamine inactivation in uterine tissues: changes in pregnancy in the rat. *Clinical and Experimental Pharmacology and Physiology*, 15, 675-680, 1988.
82. Parker, D.A.S., de la Lande, I.S. Inhibition by cocaine of noradrenaline release from sympathetic nerves in the rabbit ear artery. *Clinical and Experimental Pharmacology and Physiology*, 15, 613-617, 1988.
83. de la Lande, I.S., Kennedy, J.A., Parker, D.A.S., Parker, I., Venning, M.G. "Cocaine-sensitive extraneuronal metabolism of noradrenaline" in *Progress in Catecholamine Research, Part A. Basic Aspects and Peripheral Mechanisms*, pp. 167-171. Alan R. Liss, Inc. 1988.
84. de la Lande, I.S., Kennedy, J.A., Stanton B. "Amplifying action of 5-hydroxy tryptamine in the rabbit ear artery" in *Serotonin: Actions, Receptors, Pathophysiology. Proceedings of the 1987 IUPHAR Satellite Meeting, Heron Island, Australia*, pp. 123-129, ed. Mylecharane E.J., Angus, J.A., de la Lande, I.S. and Humphrey, P.P.A. MacMillan Press U.K., 1989.
85. de la Lande, I.S., Mylecharane, E.J. "Neuronal actions of 5-hydroxy-tryptamine: an overview" in *Serotonin: Actions, Receptors, Pathophysiology. Proceedings of the 1987 IUPHAR Satellite Meeting, Heron Island, Australia*, pp. 77-85, ed. Mylecharane E.J., Angus, J.A., de la Lande, I.S. and Humphrey, P.P.A. MacMillan Press U.K., 1989.
86. de la Lande, I.S. Amplification mechanisms in peripheral tissues; in "The peripheral actions of 5-hydroxy tryptamine" pp. 123-141 in Fozard, J.R. Oxford University Press, 1989.
87. de la Lande, I.S. Noradrenaline diffusion, metabolism and vascular response in the rabbit ear artery. *Clinical and Experimental Pharmacology and Physiology*, 16, 461-464, 1989.
88. Panek, D.U., Stitzel, R.E., de la Lande, I.S. and Head, R.J. Application of amperometric detection to the analysis of the diffusion and O-methylation of a catecholamine and a catechol steroid across the blood vessel wall. *Journal of Pharmacological Methods*, 21, 171-182, 1989.
89. de la Lande, I.S. Amplifying action of 5HT; role of  $\alpha_1$  and 5HT<sub>2</sub> receptors. *Progress in Pharmacology* (in press), 1989.
90. Falckh, HJP, de la Lande, I.S., Stitzel, R.E., Mano, M. and Head R.J. Failure of propranolol to inhibit the epinephrine-induced enhancement of responses to sympathetic nerve stimulation in the rat mesenteric vascular bed. *J. Pharm. Exp. Ther.* (in press), 1990.



## OVERVIEW VOLUME I

### Control of vascular sensitivity

#### I. Early studies on the human

The five papers in this section (4, 5, 6, 9 and 11) were in part a rediscovery in the human, of actions of adrenaline on blood flow which were already known, or suspected from animal studies, plus an account of a local vasodilator action of reserpine whose mechanism is still somewhat mysterious. The studies were carried out in collaboration with (the late) Professor R.F. Whelan and were commenced soon after both of us had been appointed to the staff of the Department of Human Physiology and Pharmacology at the University of Adelaide. He was a delightful colleague with an enormous enthusiasm for anything cardiovascular and there is no question that the association served to orientate my research interests away from cholinergic systems in brain and gut, towards adrenergic systems in blood vessels. The relevance of the human studies to one of the major topics in this thesis are that they drew my attention very forcibly to the (then) paucity of information available from animal studies, on the factors which controlled access of vasoactive substances to their target sites (i.e. the receptors) in the smooth muscle. In particular, there was a need for an in vitro artery model which could mimic the conditions which prevailed in vivo, where the normal routes of access were via the lumen, or, as was the case with the NA released from the intramural sympathetic nerve terminals, via the adventitia. The development of such a model is the subject of the papers in the following section.

#### II. The perfused rabbit ear artery segment.

The papers in this section are set out in historical sequence of the research rather than in the order of their appearance in the literature. The first paper (59) is an anecdotal account of the development of the in vitro ear artery preparation which appeared as a Citation Classic in Current Contents in 1980. The second paper (32) describes the study on catecholamine release in the isolated but intact ear of the rabbit in the course of which the isolated artery preparation "emerged". The study was carried out in collaboration with W.D.M. Paton in the Department of Pharmacology, University of Oxford, in 1963. It appeared as an abstract in 1964, and as a full paper in 1968. In the interim I enlisted the help of Michael Rand to carry out a detailed characterisation of the pharmacological potential of the artery preparation, the results of which appear in the next paper (14); the paper is the subject of the Citation Classic referred to above. Some additional characterisation is contained in the last two papers (15, 33) in this section. In each of the above studies, the artery was cannulated at its proximal end only, so that the same Krebs solution which had perfused the lumen subsequently bathed the adventitial surface. This problem was avoided by cannulating the distal end also. This modification, documented in 1966 (paper 17 in Section IV) permitted analysis of drug action according to the surface of entry into the artery wall. This type of analysis was used extensively in the studies in the following section.

III. Interrelationships between diffusion, disposition and action of catecholamines in the isolated perfused artery. This section includes four reviews; of which the most detailed (48) encompasses studies to 1974 while the last (87) although brief, encompasses studies to 1989.

(i) Role of uptake<sub>1</sub> in the vasoconstrictor response to noradrenaline and related amines.

Paper 21 is the key one. It documents the profound influence of the surface of entry of noradrenaline (NA) on the vasoconstrictor response, and on the modification of the response by procedures (sympathectomy) or drugs (cocaine) which eliminate uptake<sub>1</sub>. In particular, entry via the intima was associated with high sensitivity to NA and low sensitivity to cocaine; the converse applied when entry was confined to the adventitial surface. These differences were attributed entirely to the highly localised distribution of the sympathetic nerve terminals at the medial-adventitial border (Fig.1).

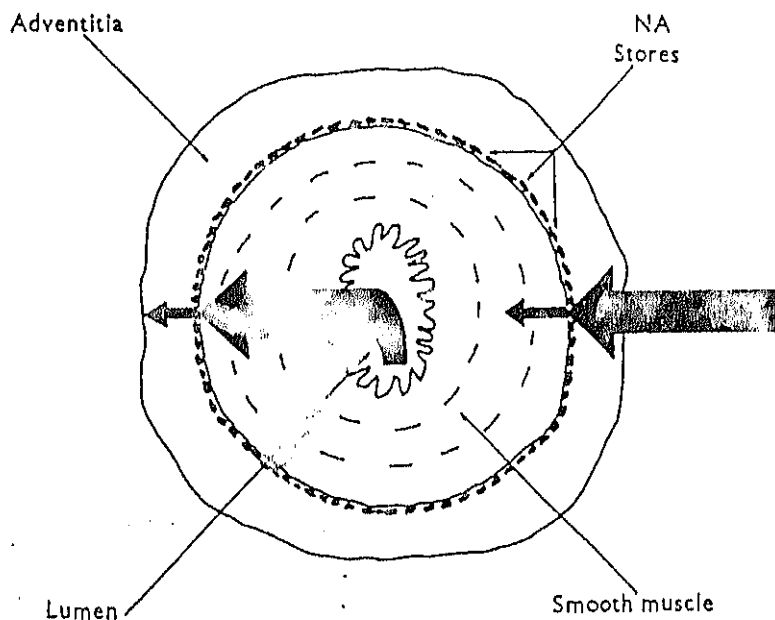

Fig. 1. Diagrammatic representation of the influence of the sites of uptake (shown as NA Stores) on the concentration of adrenaline in the smooth muscle of the artery. The arrow indicates the direction of diffusion, and its thickness the concentration of noradrenaline.

That the model in Fig. 1 had considerable validity was indicated by experiments in which the effects of NA were compared with those of (a) directly-acting amines differing in their affinities for uptake<sub>1</sub> e.g. adrenaline (55) methoxamine (36) and (b) amines (e.g. tyramine) which acted indirectly by releasing NA from the sympathetic nerve terminals (30, 37). Also in accord with the model was the finding that the potency of dopamine, which is a weak vasoconstrictor, was independent of the surface of amine entry (45).

(ii) Role of monoamine oxidase, (MAO).

That MAO was present in high concentrations in the media and represented an enzymic barrier to the diffusion of intraluminal tyramine to the nerve terminals, was indicated by the study in paper 37. The extraneuronal MAO was capable of metabolising NA in high concentrations (40). However histochemical and pharmacological analysis of the effects of MAO inhibition revealed that at low concentrations of NA, only the neuronal enzyme played an important role in the action and inactivation of the amine. Furthermore, in the MAO inhibited artery, access of intraluminal NA to the nerve terminals was limited compared with that of the extraluminal amine (36 and 42). The latter finding led to revision of the model in Fig 1 to take into account the presence of a gradient of NA concentration (i.e. a diffusion gradient) across the media (see model in Fig 2).

(iii) Role of uptake<sub>2</sub>.

That uptake<sub>2</sub> contributed to the diffusion gradient was indicated in the histochemical study (42), yet a pharmacological study (55) revealed only a slight effect of uptake<sub>2</sub> inhibition on the vasoconstrictor response to NA. However the latter study showed that uptake<sub>2</sub> inhibitors exerted a marked potentiating effect on the vasoconstrictor response to adrenaline. The effect was largely independent of the surface of amine entry, a finding which accorded well with early histochemical evidence of Gillespie that the sites of uptake<sub>2</sub> were confined to the media. It appeared from these findings that the affinity for NA for uptake<sub>2</sub> was too low to expedite removal of the amine from the receptor biophase yet was sufficient to cause loss of the intraluminal amine as it diffused across the media to the nerve terminals.

(iv) Role of catechol O methyl transferase (COMT).

Effects of COMT-inhibition closely resembled those of uptake<sub>2</sub> inhibition. Thus the histochemical study referred to above (42) indicated that COMT inhibition facilitated access of intraluminal NA to the sympathetic nerve terminals. The inhibition was associated with a modest increase in the sensitivity (two fold) to intraluminal NA but a considerably greater increase in sensitivity to intraluminal adrenaline. A marked increase in the time course of the response to adrenaline was prevented by uptake<sub>2</sub> inhibition. The latter results, which accorded well with evidence of Trendelenburg and his colleagues, that uptake<sub>2</sub> was followed by intracellular O-methylation, were reported in the Ph.D. thesis of S.M. Johnson, University of Adelaide, 1975.

The conclusion drawn from these studies, namely that uptake<sub>2</sub>-linked O-methylation contributed in part to the diffusion gradient of NA in the media was incorporated in the model in Fig 2. Whether a gradient of concentration of intraluminal NA existed under conditions where both uptake<sub>1</sub> and uptake<sub>2</sub> were inhibited was examined in the pharmacological study included in the review-type paper (58). The results indicated

**Note:** The model in Fig. 2 refers to the rabbit ear artery. In the rat tail artery uptake<sub>2</sub> appears to play little role in the disposition of either adrenaline or NA (67).

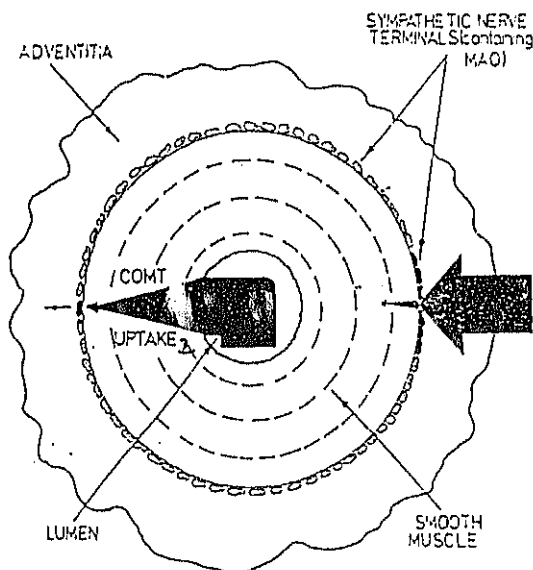

**Fig. 2.** The model in Fig. 1 modified to take into account the diffusion gradient in the media, and the possible contribution to this gradient of uptake<sub>2</sub>-linked O-methylation.

#### (v) Metabolic studies

At an early stage of the above studies it was appreciated that a critical assessment of the factors controlling diffusion of NA within the artery wall required quantitative indices of neuronal and extraneuronal uptake. Ideally these would permit repeated determinations on the same artery segment during the course of a single experiment. Appropriate indices emerged from the pioneering studies of Langer at Brabham and of Trendelenburg at Wurzburg, who showed respectively that dihydroxyphenyl ethylene glycol (dopeg) was the principal neuronal metabolite of NA, and that at low concentrations of NA, normetanephrine (NMN) was the principal extraneuronal metabolite whose formation depended on uptake<sub>2</sub>. When the "metabolic" approach was commenced the current methods for estimating dopeg were too unwieldy to be useful for our purpose and for this reason a student in my laboratory, Richard Head, in the early 1970s, devoted part of his Ph.D. project to improving methods for the assay of catecholamine metabolites. A suitable method based on thin layer chromatography (54 in Section VI) was developed and used extensively in our early studies. It was eventually replaced by the column chromatographic method reported by Graefe, Stephano and Langer in 1973 when it became apparent that their method was faster.

After characterising the pattern of metabolism in the artery segment to an extent which confirmed the neuronal origin of dopeg and extraneuronal origin of NMN (49, 1A), attention was focussed on differences between the metabolisms of intraluminal and of extraluminal

NA. The results (58) confirmed both the importance of uptake<sub>1</sub> in limiting access of extraluminal NA to the underlying smooth muscle, and the relative inaccessibility of the sympathetic nerve terminals to intraluminal NA. The decrease in concentration of the intraluminally-applied amine between the site of entry (intimal surface) and the medial-adventitial border was estimated to be 90% but was revised to about 80% in a later study (78; see also 87). The results of the later study indicated that uptake<sub>2</sub> inhibition led to an approximate-doubling of flux of the intraluminal amine into the region of the nerves. By subtraction it appeared that the gradient remaining after eliminating uptake<sub>2</sub> amounted to an approximate 70% decrease in concentration of the amine between the intimal surface and the region of the nerves. The latter gradient was attributed to physical resistance to diffusion within the media.

Evidence that the media was the major diffusion barrier to NA in an artery (rabbit aorta) had been provided earlier by John Bevan and his colleagues. In my laboratory, the relative magnitudes of the diffusion barriers in the rabbit ear artery posed by the media and adventitia was highlighted by an early finding that, in the phenoxybenzamine treated artery (to eliminate both uptake<sub>1</sub> and uptake<sub>2</sub>) NA released by nerve stimulation effluxed about 5 times more rapidly from the adventitial than from the intimal surface (2A). These patterns of efflux were mimicked by those of dopeg in a later experiment where metabolising systems were preserved, and NA was either released by nerve stimulation (69) or was applied to either surface (78). The results were interpreted in terms of diffusion theory which predicts a steeper gradient of concentration in the region of lower diffusivity (Fig 3).

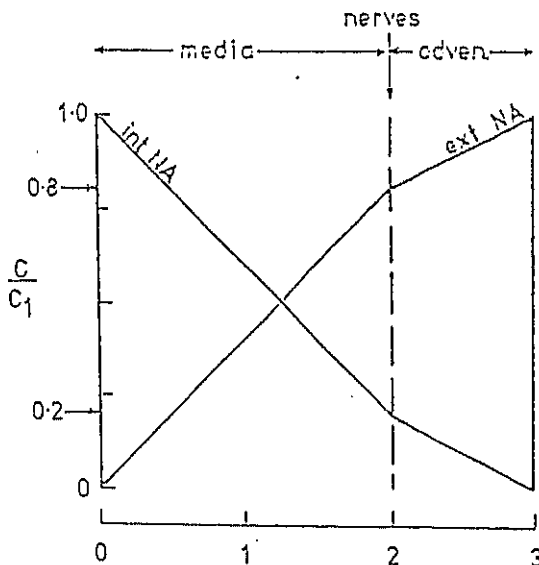

Fig 3. Predicted gradients of concentration within the artery wall when NA enters via the intimal (INT) or adventitial (EXT) surface. It is assumed that

- (a) the media is twice as thick as the adventitia,
- (b) the diffusivity of NA in the media is one-half that in the adventitia, and
- (c) the wall behaves like the depth of a plane sheet with respect to the diffusivity of NA.

$C$  = concentration of NA at any point within the wall

$C_1$  = concentration of NA at the surface.

The diffusion gradients in that Figure 3 are idealized in that they take no account of the influence of removal by uptake. The influence (steepening of the gradient) becomes important when the rate of uptake at a site of removal is limited by the rate at which the amine can diffuse to that site. The evidence presented in paper 78 suggests that the rates of neuronal uptake of intraluminal NA and, to a lesser extent extraneuronal NA, are diffusion-limited, and hence the relationship between surface of amine entry and uptake<sub>1</sub> cannot be explained solely in terms of diffusion gradients. Note:- In the case of extraluminal NA, evidence is presented in paper 78 which suggested that the diffusion-limitation may not apply to the nerve terminals closest to the adventitial surface. It is speculated that the limitation is imposed by progressive loss of NA by uptake as it diffuses inwards through the layers of nerve terminals.

In contrast, the relationship between surface of entry and disposition of NA by uptake<sub>2</sub> (using NMN formation as the measure of uptake<sub>2</sub> activity) conformed quite well with a model based on diffusion gradients only. The model, shown in Fig. 4, was simplified from Fig. 3 by ignoring the adventitia both as a site of uptake<sub>2</sub>-mediated O-methylation, and as a diffusion barrier. The model predicts that the quantity of NMN formed when NA enters by one surface is doubled when NA enters both surfaces simultaneously, and that the NMN effluxes preferentially (in a 2:1 ratio) from the surface of NA-entry. The experimental data (78) agreed quite well with these predictions.

O-methylation which was resistant to uptake<sub>2</sub>-inhibition was noted in two studies (78 and 68; 68 refers to an extracellularly mediated O-methylation in the rabbit aorta). However the resistant components were of small magnitude compared with the uptake<sub>2</sub>-mediated component.

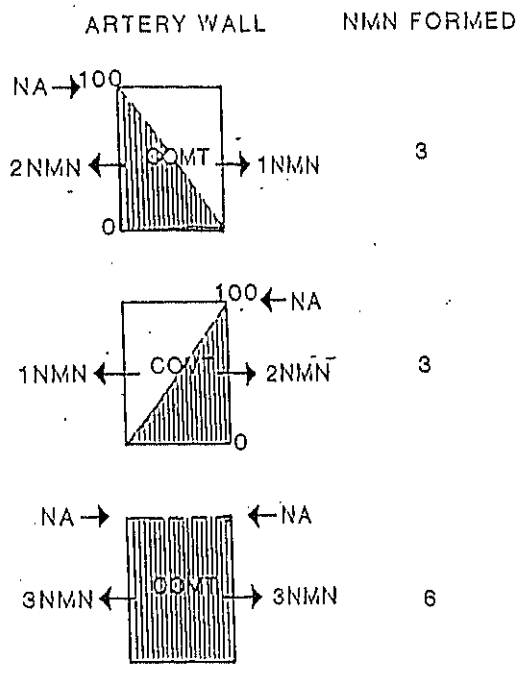

Fig. 4 Predicted patterns of NMN formation and efflux when NA is applied to the intimal surface (upper), the adventitial surface (middle) or both surfaces simultaneously (lower). It is assumed that 3 molecules of NMN are formed when 100 molecules/unit volume of NA is applied to one or other surface. The artery wall is equated with the media. The broken line is the steady-state gradient of concentration and the shading is the quantity of NA in the wall.

The preceding metabolic studies were carried out on arteries (termed relaxed) where the constrictor activity of NA was prevented to avoid confounding variables when comparing the metabolism of intraluminal and extraluminal NA. The final paper (79) in the series describes the changes in metabolism of intraluminal NA when the artery was allowed to constrict. The results are compared with the effects of distending relaxed arteries to achieve a decrease in wall thickness. Dopag formation from intraluminal NA conformed well with the earlier evidence that neuronal uptake is determined by the rate of diffusion of the NA through the media. However in the arteries exposed to intraluminal NA, NMN formation and efflux departed in some respects from the patterns predicted from the model in Fig 4. One departure was the tendency for NMN formation to decrease in the constricted vessel. This was attributed to a tendency for depolarisation of the contracting smooth muscle to inhibit uptake<sub>2</sub>; evidence for such an effect had been obtained earlier by Trendelenburg in heart muscle. In retrospect, the decrease may also reflect the decreased rate of diffusion of NA across the thickened wall, and a resultant greater tendency for the rate of NMN formation to become diffusion-limited. This might account for the seemingly-dramatic effect of uptake<sub>2</sub> or COMT inhibition on access of intraluminal NA to the nerve terminals which was seen in the earlier histochemical study (42). In that study, the vessels were highly constricted by the NA.

**Added note:-** Endothelial function was tested only in separate experiments where vessels were constricted under identical conditions to those used in study no. 79. That the function was preserved was suggested both by consistent dilator responses to ACh, and by electron-microscopic examination (to be reported).

#### VI. Factors influencing entry of NA into the artery wall (Papers 78 and 79).

By confining entry of NA to one surface, it was possible to measure the quantity entering per unit time in terms of the sum of (a) the quantity leaving the opposite surface, (b) the quantity present in the tissue, and (c) the quantity of total metabolites formed. When 'balance sheets' were compared, it was evident that under certain conditions inhibition of metabolism resulted in a decreased entry of NA. The conditions were those where uptake and metabolism accounted for most of the amine before it diffused from the opposite surface, namely (a) for intraluminal NA, extraneuronal uptake and O-methylation and (b) for extraluminal NA, neuronal uptake and deamination. The results imply that removal of amine at a site of loss, if of sufficient magnitude, is capable of accelerating diffusion of amine to that site.

Constriction of the artery was also associated with decreased entry of intraluminal NA. Whether this was also the case with extraluminal NA could not be assessed in view of its weak vasoconstrictor activity. The decreased entry of the intraluminal amine reflected both the decreased neuronal deamination (a predictable consequence of the diffusion limitation discussed above) and the decreased O-methylation. These results draw attention to the intriguing possibility that the rate at which NA diffuses to its receptors in the smooth muscle, as well as the rate of diffusion to sites of loss, decreases after constriction of the artery is initiated by activation of these receptors. This possibility

8.

together with the effects of uptake and metabolism, is represented diagrammatically in Fig 5. Fig 5 indicates the stage which has been reached in the study of the interrelationships between diffusion, uptake and response to NA in the perfused artery segment. It seems appropriate to conclude studies which commenced with the aim of exploring the influence of uptake and metabolism on the vasoconstrictor response to NA, by proposing that the vasoconstrictor response in turn influences uptake and metabolism.

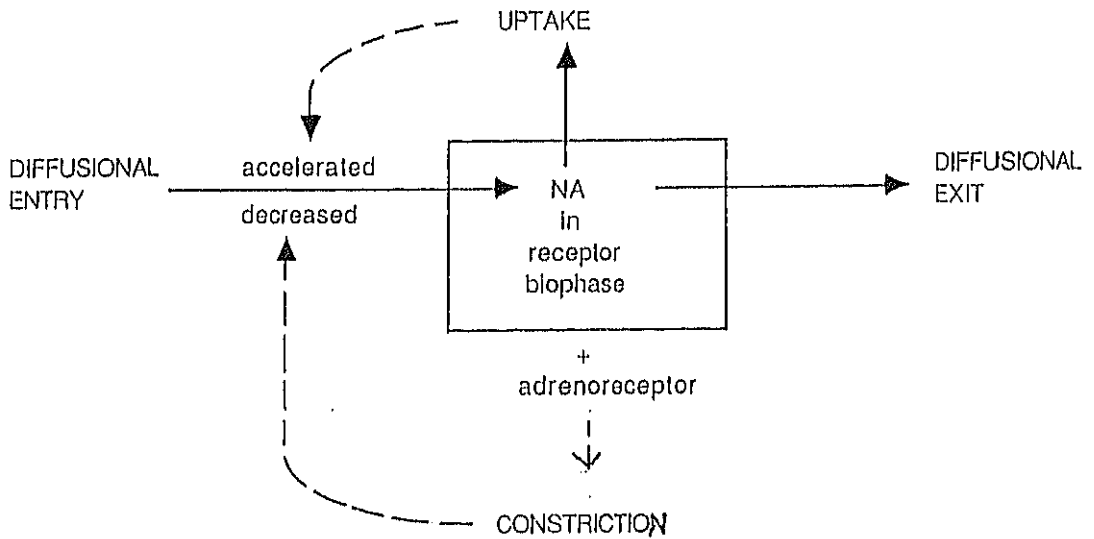

Fig. 5. Feedback modulations of NA concentration in the receptor biophase by uptake and constriction. The unbroken arrows indicate the movement of NA. The broken arrows indicate the effect on diffusional entry of removal by uptake and of constriction.



#### IV Interactions with other vasoactive substances.

Acetyl choline (ACh): the ability of ACh to inhibit the vasoconstrictor effects of sympathetic nerve stimulation in the rabbit ear artery had been documented in the early study with Michael Rand (14). The effect was further characterised by a Ph.D. student in my laboratory (R.W. Hume) and shown to be presynaptic in location (39), prompting the thought that it might reflect a functional or interactive role of ACh in sympathetic nerve transmission (as has been proposed earlier by Burn and Rand). The possibility was encouraged by an analysis of the distribution of acetyl and butyryl cholinesterases in the artery which indicated that the former enzyme was associated with the sympathetic nerve terminal (35). Nevertheless attempts to demonstrate the presence of choline acetyl transferase in the artery were unsuccessful (reported in the Ph.D. thesis entitled "Cholinergic factors and vascular tone"; W.R. Hume; University of Adelaide, 1973). For this reason the study was discontinued.

(ii) Prostaglandins: Paper 47 describes effects of prostaglandin E<sub>2</sub>, its precursor, and two cyclooxygenase inhibitors on contractile effects of NA and of sympathetic nerve stimulation. It represents an early assessment of the possibility that contraction and/or sympathetic transmission in arteries was modulated by prostaglandins released from the contracting muscle.

(iii) Serotonin (5HT): An amplifying effect of 5HT on the responses to other vasoconstrictor agents of the perfused rabbit ear and coronary arteries and also the human digital artery, was documented in papers 17, 25 and 44 (44 is in Section III). Its occurrence in vivo was demonstrated in the anaesthetised rabbit by an M.Sc. student (Victoria Cannell) and is illustrated in Fig 6.4 in paper 86. The 5HT receptor responsible for the effect appeared at the time to be unusual since it was activated by one 5HT antagonist (methysergide), but blocked by another (bromlysergide) (17). The paucity of 5HT antagonists then available led to abandonment of the study until the early 1980's, when the 5HT<sub>2</sub> selective antagonist ketanserin appeared. It was hoped that ketanserin would quickly resolve the nature of the 5HT receptor involved in the amplifying action, but the effects of the drug proved equivocal comprising a) inhibition of the interaction with NA which appeared to be associated with alpha-adrenoceptor blockade, b) less effect on the interaction with methoxamine and, c) potentiation of the interaction with histamine. Evidence that the potentiation was related to histamine H<sub>2</sub> receptor activation which was "unmasked" by the H<sub>1</sub> receptor antagonist action of ketanserin, is presented in paper 84. Major papers describing the interactions involving NA and methoxamine are in the course of preparation, but the above and other findings are summarised in an extensive review (86). Results of a current study suggest that the effects of ketanserin and another antagonist considered to be selective for the 5HT<sub>2</sub> receptor (LY53857), on the amplifying action interaction, with methoxamine, may be due to blockade of a receptor of the 5HT<sub>1</sub> subtype. An abstract is to be presented at the second International Satellite Meeting on Serotonin in Basle in July of this year; it is included here (3A).

(iv) Histamine: Dr. Andrew Foldes, a postdoctoral fellow in my laboratory, examined the disposition of histamine in the rabbit aorta, and showed that uptake and deamination of the amine was prevented by an inhibition of uptake<sub>2</sub> (53). The result supported the results of the pharmacological studies on the rabbit aorta by Kalsner, and on the rabbit ear artery in my laboratory (53) which implied that histamine is a substrate for uptake<sub>2</sub>.

## VOLUME 2

## Studies on tissues other than arteries

## V. Noradrenaline disposition in reproductive and connective tissue.

(i) Female reproductive organs

The studies on reproductive tissue were undertaken initially to establish whether chronic exposure to uptake<sub>2</sub> inhibitors influenced catecholamine disposition. Female reproductive organs were selected in view of their exposure periodically to high concentrations of ovarian hormones, which were known to be uptake<sub>2</sub> inhibitors in vitro. To this end, the effects of ovarian hormones and of pregnancy on disposition of NA in the oviduct, ovary, and uterus of the rabbit were studied in a Ph.D. project by J.A. Kennedy, commenced in the mid 1970s. It was found that uterine metabolism of NA became predominantly extraneuronal during a state of progesterone-predominance, (63) and during pregnancy (64). In the mid 1980s, when Dr. Kennedy returned to my laboratory as a post doctoral fellow, we decided to re-explore the stimulation of extraneuronal metabolism of NA (in particular, O-methylation) by progesterone, but using separated myometrial and endometrial slices of the uterus. The results (73) revealed that in both regions extraneuronal O-methylation responded about equally to the progesterone treatment but was uptake<sub>2</sub> dependent only in the myometrium. In the endometrium, O-methylation although entirely extraneuronal, was blocked by inhibitors of uptake<sub>1</sub>. Coincidentally a few days before this finding a student (Ines Parker) who was carrying out research in my laboratory for the honours degree of Bachelor of Dental Science, had noted that extraneuronal O-methylation of NA in rabbit gingival tissue was blocked by inhibitors of uptake<sub>1</sub> (71; see also below). Hence unexpectedly, it appeared that an uptake process resembling uptake<sub>1</sub> (provisionally called uptake<sub>3</sub>) accounted for most of the extraneuronal removal of NA in two quite different tissues. Although the presence of an extra-neuronal uptake<sub>1</sub>like process in pulmonary endothelium was already known as a result of the pioneering work of Gillis, its occurrence was generally regarded as exceptional. Since the present results suggested otherwise, it was decided to characterise the uptake process with the aim of establishing whether it was identical with neuronal uptake<sub>1</sub>. The results are presented in paper 75 and briefly reviewed in paper 83. The only major kinetic difference between uptake<sub>3</sub> and uptake<sub>1</sub> was an apparently 70 fold lower affinity of the former process for NA. The difference has since been traced to the presence in the endometrium of a second uptake process, which operates at high NA concentration and which distorted the Km for uptake<sub>3</sub> reported in paper 75. When the second uptake was taken into account, the Km for NA uptake was of similar magnitude to the Km for neuronal uptake<sub>1</sub> (abstract 4A). The presence of uptake<sub>3</sub> in the female reproductive organs of other species was suggested by findings that O-methylation in pregnant rat uterus and in placenta is blocked by an uptake<sub>1</sub> inhibitor (81).

(ii) Connective tissue; oral and nasal

A collaborative study with Dr. D.A.S. Parker, Senior Lecturer in Dentistry, revealed that extraneuronal metabolism of NA in slices of dental pulp proceeded almost entirely by O-methylation, and that the O-methylation process was blocked by uptake<sub>1</sub> inhibitors (74). In a

subsequent study, reported so far only in abstract form (4A), the affinities of a variety of amines for the uptake process were measured and found to correspond very closely with their affinities for neuronal uptake<sub>1</sub>. Hence in this tissue at least, it seems probable that "uptake<sub>3</sub>" is an extraneuronal uptake<sub>1</sub>.

Trendelenburg has proposed the use of the term "metabolising system" to describe the process whereby the catecholamine is removed by uptake in series with a metabolising enzyme. The classical systems are the neuronal metabolising system where uptake<sub>1</sub> is linked with MAO, and the extraneuronal metabolising system where uptake<sub>2</sub> is linked with COMT. The studies reported here draw attention to a third metabolising system where an extraneuronal uptake<sub>1</sub>-like process is in series with COMT (see Fig. 6). The possibility that this third system is widely distributed is raised by findings that cocaine sensitive O-methylation is also present in gingival tissue and in nasal mucosa of the rabbit (76). The cell types involved have only been identified in the uterine endometrium (glandular epithelial cells) and in dental pulp (a primitive fibroblast precursor of the odontoblast). Fortunately for the interpretation of the studies on vascular sensitivity outlined in section 3, the third metabolising system appears to be absent in the rabbit ear artery (80, 83).

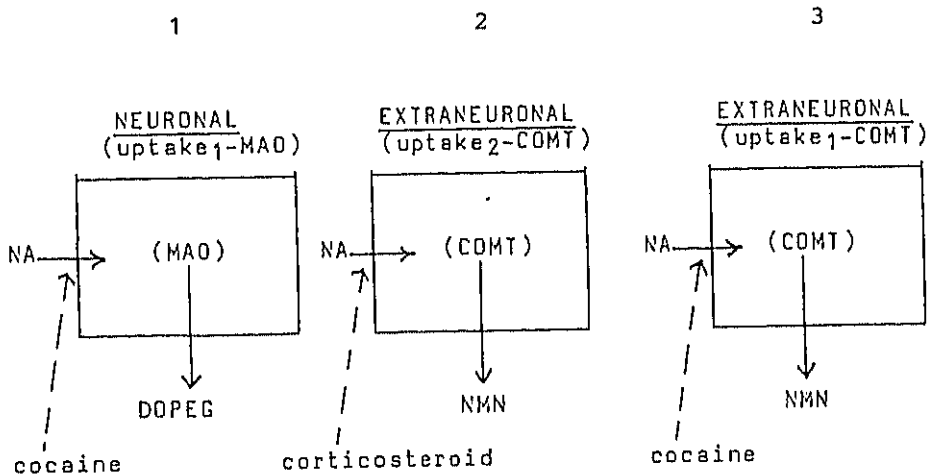

Fig 6. NA METABOLISING SYSTEMS

## VI Methodological and related studies

This section comprises studies relating to

- (a) detection and assay of catecholamines (18, 20, 29, 51, 54, 88)
- (b) interpretation of dose-response data (41)

Included in this section are two early papers relating to diagnoses of carcinoid syndrome and pheochromocytoma, where my only role was to supervise the relevant assay procedures.

Attention is drawn to the study in paper 88, which shows that continuous amperometric detection of catecholamines in Krebs solution is a feasible proposition. The study was a collaborating exercise with Professor Richard Head in his laboratory at the University of West Virginia.

## VII. Aminergic mechanisms in brain, heart and gut

Again this is a mixed group of studies, mainly early. Topics include

- (a) opiates and cholinergic transmission (3, 10, 24)
- (b) autonomic transmission in a reptile heart (8, 16)
- and
- (c) catecholamine uptake and metabolism in marsupial brain (65, 66).

The study in (c) is the most recent. It was intended to establish whether catecholamine disposition in the tissue slice reflected the "in vivo" situation. Unfortunately, the "in vivo" part of the study, utilizing the push-pull cannula technique, was marred by the finding that the  $^3\text{H}$  noradrenaline belonged to a batch which was falsely labelled (reported by overseas investigators). This problem did not apply to the "in vitro" study, and hence the latter was reported.