

PUBLISHED VERSION

A. C. Zecchin, J. Gong, A. R. Simpson, M. F. Lambert

Condition assessment in hydraulically noisy pipeline systems using a pressure wave splitting method

Procedia Engineering, 2014 / Giustolisi, G., Brunone, B., Laucelli, D., Berardi, L., Campisano, A. (ed./s), vol.89, iss.2014, pp.1336-1342

© 2014 The Authors. Published by Elsevier Ltd. This is an open access article under the CC BY-NC-ND license <http://creativecommons.org/licenses/by-nc-nd/3.0/>

Originally Published at:

<http://dx.doi.org/10.1016/j.proeng.2014.11.452>

PERMISSIONS

You are free to:

Share — copy and redistribute the material in any medium or format

The licensor cannot revoke these freedoms as long as you follow the license terms.

Under the following terms:



Attribution — You must give **appropriate credit**, provide a link to the license, and **indicate if changes were made**. You may do so in any reasonable manner, but not in any way that suggests the licensor endorses you or your use.



NonCommercial — You may not use the material for **commercial purposes**.



NoDerivatives — If you **remix, transform, or build upon** the material, you may not distribute the modified material.

No additional restrictions — You may not apply legal terms or **technological measures** that legally restrict others from doing anything the license permits.

06 March 2015

<http://hdl.handle.net/2440/89586>

Condition assessment in Hydraulically noisy pipeline systems using a pressure wave splitting method

by

Zecchin, A. C., Gong, J., Simpson, A. R., and Lambert, M. F.

15th Water Distribution Systems Analysis Conference (WDSA 2014)

Citation:

Zecchin, A. C., Gong, J., Simpson, A. R., and Lambert, M. F. (2014). "Condition assessment in hydraulically noisy pipeline systems using a pressure wave splitting method". *15th Water Distribution Systems Analysis Conference (WDSA 2014)*, American Society of Civil Engineers, Bari, Italy.

For further information about this paper please email Angus Simpson at angus.simpson@adelaide.edu.au



16th Conference on Water Distribution System Analysis, WDSA 2014

Condition Assessment in Hydraulically Noisy Pipeline Systems Using a Pressure Wave Splitting Method

A. C. Zecchin^{a*}, J. Gong^a, A. R. Simpson^a, M. F. Lambert^a

^a*The School of Civil, Environmental and Mining Engineering, The University of Adelaide, South Australia*

Abstract

For the past couple of decades, researchers have been investigating the use of hydraulic transients (pressure surge waves) to investigate the condition of a pipeline system, and detect anomalies such as leaks, blockages, or pipe wall condition. The use of controlled hydraulic transients, combined with signal processing methods on measured pressure responses, have had a demonstrated utility for pipeline condition assessment, largely owing to the sensitivity of the hydraulic transient waves to the said anomalies. This paper presents a simple extension to these existing methods by proposing a technique that does not require a controlled hydraulic transient input, but utilizes existing hydraulic noise (in the form of wide-sense stationary hydraulic signals) within the system of interest to perform the diagnosis.

© 2014 Published by Elsevier Ltd. This is an open access article under the CC BY-NC-ND license (<http://creativecommons.org/licenses/by-nc-nd/3.0/>).

Peer-review under responsibility of the Organizing Committee of WDSA 2014

Keywords: Hydraulic transients; Pipeline condition assessment

1. Introduction

Condition assessment of pipeline infrastructure is of critical importance for prudent asset management. Given the large scale of pipeline infrastructure, there is a great practical interest in the development of condition assessment methods that are cost effective to implement on these large scales [1]. One such approach that has shown great promise in the research literature is the use of hydraulic transients [1-6]. In these techniques, hydraulic pressure waves are induced into the pipeline system under consideration (through some form of pressure wave generator), and the pressure response of the system is measured and analyzed to detect the presence of condition faults (i.e. leakage points, blockages, and pipe wall condition). For the accurate and reliable application of these methods, the hydraulic

* Corresponding author. Tel.: +61-(0)8-8313-3027; fax: +61-(0)8-8313-4359.

E-mail address: aaron.zecchin@adelaide.edu.au

conditions within the pipeline system are required to be quiescent, or near quiescent conditions. That is, in situations where the background hydraulic noise within the system is significant, the induced pressure signals may be contain noise to the extent to where they are unusable for the traditional condition assessment methods. However, a noted exception to this work is the pipeline parameter estimation work of Zecchin et al. [7, 8], which utilized noisy nodal measurements of pressure and flow within arbitrary network configurations to estimate the parameters within these networks.

In contrast to these previous methods where this background hydraulic noise is viewed as a nuisance to condition assessment methods, the work proposed within this paper shifts focus to view this background hydraulic noise as a useful form of system excitation. That is, rather than inducing an interrogation wave into the system, the background hydraulic noise is used as the form of excitation from which the condition assessment method is developed. The proposed method adopts a multi-step approach. Firstly, system noise is measured using a paired pressure transducer array. From knowledge of the system characteristics, the power and cross spectra of the paired pressure measurements are used to determine the power and cross spectra of the axial positive and negative travelling waveforms. Once the power and cross spectra of the waveforms are determined, the impulse response of the system section under consideration (i.e. the section downstream of the paired pressure sensors) is determined. This system impulse response reveals the presence of condition faults within the pipeline system, where faults appear as reflected peaks in the response function. The proposed method is tested on a numerical case study involving a 2 km long transmission main with two corroded points located along its length. From the initially noisy data, the method is able to correctly reconstruct the impulse response, and show the presence of the corroded sections.

2. Problem outline

The method outlined within this paper deals with the scenario depicted in Fig. 1. Within this scenario, there is a long section of a transmission line that requires condition assessment. The proposed method requires that the transmission line section is bounded upstream by an active boundary condition, and downstream by a non-active boundary condition. An active boundary condition, is one for which the hydraulic variables of head and flow are varied with time due to an external (upstream) influence, which is the source of the hydraulic noise.

A non-active boundary condition is taken to mean a boundary condition that possesses no time varying properties, and does not serve to induce transient events. Examples of non-active boundary conditions are storage tanks or discharge valves, or closed valves. As will be seen, the requirement for a non-active boundary condition is to ensure that the measured transient waves are induced from the active upstream boundary condition.

To undertake the condition assessment of the section of interest, two pressure transducers are located just downstream of the active upstream boundary condition. The question of interest within this paper is the utilization of the two closely spaced pressure measurements for the detection of condition faults within the downstream transmission main.

3. Development of proposed method

3.1. Basic theory

The transient behavior of the hydraulic variables of pressure and flow rate can be expressed using the standard 1-D water hammer equations (e.g. [9]). These hyperbolic equations describe a nonlinear wave propagation phenomena, where the hydraulic state at any single point can expressed as terms dependent on the positive travelling hydraulic perturbations from upstream of the point, and the negative travelling perturbations from downstream of the point. Neglecting the nonlinear influences (which are small for mild perturbations about some mean operating state), the pressure at any point x can be given by

$$p(x,t) = p^+(x,t) + p^-(x,t) \quad (1)$$

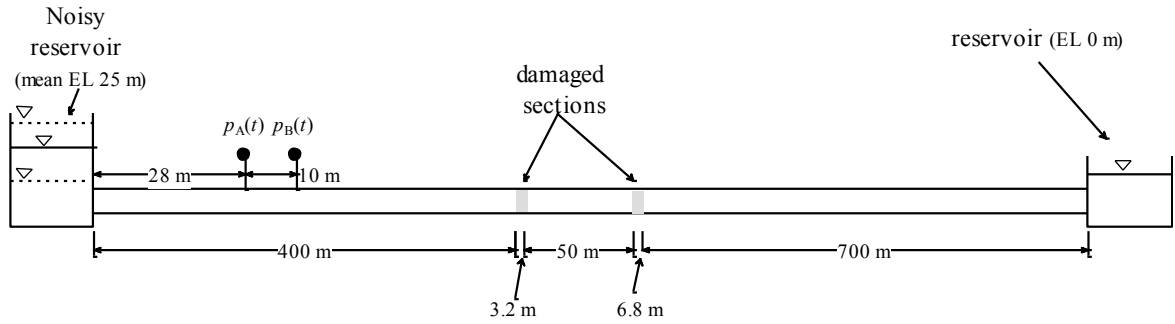

Fig. 1. Example boundary condition and measurement scenario for which the method is to be applied. Note that the upstream boundary is an active boundary, and the downstream boundary is a non-active boundary.

where p^+ is the pressure term associated with a positive traveling transient pressure wave, and p^- is the pressure term associated with the negative traveling pressure wave. As will be demonstrated, an advantage of considering the directional wave components is that the information travelling downstream the pipe can be decoupled from the information travelling upstream the pipe.

An advantage of the linear wave theory for water hammer analysis, is that it enables an analytic analysis of the wave propagation terms within the frequency-domain (or, as in the equations below, the Laplace-domain more generally). That is, dealing with the transformed variables (represented in capital letters), the positive travelling wave pressure terms can be related to their upstream and downstream counterparts as follows

$$P^+(x,s) = e^{-\Delta x \Gamma(s)} P^+(x - \Delta x, s) \tag{2}$$

$$P^-(x,s) = e^{-\Delta x \Gamma(s)} P^-(x + \Delta x, s) \tag{3}$$

where Δx is spatial distance, s is the Laplace variable, and $\Gamma(s)$ is termed the propagation operator, as it is this operator that describes the frequency-domain behavior of wave propagation (attenuation and phase change). For a 1-D standard water hammer model with steady friction, the propagation operator is given by

$$\Gamma(s) = \frac{1}{c} \sqrt{s \left(s + f \frac{Q_0}{DA} \right)} \tag{4}$$

where c is the wave speed, f is the Darcy-Weisbach friction factor, Q_0 is the steady-state operating flow rate, D is the pipe diameter, and A is the cross-sectional area. The interested reader is referred to [6] for further details.

A directional travelling wave will propagate freely down a pipe described by the relationships outlined in (2,3) until it encounters a change of impedance. Changes of impedance can be caused by changes in the cross-sectional properties of the pipe, which typically happen as a result of a degraded section of pipe. At impedance changes, part of the wave energy is transmitted through the change, and part is reflected. The size of the reflected wave is indicative of the change in impedance, which can be further used to estimate the change in wall thickness [1].

3.2. Development of detection methodology

Considering the scenario depicted in Fig. 1, an intact pipe will cause no reflections in incident water hammer waves, but a pipe with damage(s) will reflect incident pressure waves at the damage locations. Previous work dealing with either step or pulse excitations, has analyzed these reflections purely from the pressure trace [1, 2, 4]. However, such direct analysis is not possible when dealing with complex excitations (such as hydraulic noise), as the pressure traces can contain many peaks, and are not directly interpretable. Given this, a two-step approach to condition assessment is proposed based on utilizing information available from two closely spaced transducers: Step 1) Decouple the measured pressure traces into the positive and negative travelling wave components; Step 2) Use the positive and negative components as inputs and outputs to identify the impulse response function of the downstream section of pipe. The analysis of this impulse response will consequently enable the assessment of the pipe condition, as an impulse response that contains reflection terms will be indicative of a section of pipe that contains degraded sections.

3.2.1. Decoupling the directional waves

A wave decoupling algorithm was proposed by Gong et al. [3] using two pressure transducers but a step wave excitation, this is generalized within this research to wide-sense stationary excitation signals. The block diagram structure of the transducer pair is given in Fig. 2(a), where it is assumed that the section of pipe between the transducers is uniform, and P_A^+ is the positive travelling wave travelling down the pipe from the upstream reservoir, and P_B^- is the negative travelling wave that is reflected from the downstream section of pipe.

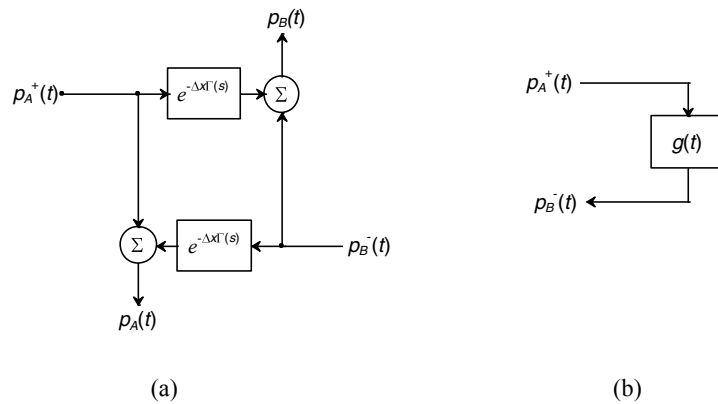

Fig. 2. (a) The block diagram structure used in Step 1 indicating the dependency between the pressure measurements p_A and p_B and the positive travelling wave p_A^+ and negative travelling wave p_B^- ; (b) the system identification problem in Step 2 where the input is p_A^+ and output is p_B^- .

The pressures at A and B are seen to depend on the positive travelling wave P_A^+ and negative travelling wave P_B^- , where this relationship can be manipulated to yield expressions for the travelling wave components as a function of these pressure measurements.

3.2.2. Identification of system impulse response

As depicted in Fig. 2(b), the system identification process involves determining the impulse response of the system that maps from the input P_A^+ (the transmission wave coming from the upstream reservoir) to the output P_B^- (the reflected wave from the downstream pipe section). That is, it is desired to determine the impulse response function g , as this will reveal all the reflection-based information that is used to detect damaged sections. So theoretically, the relationships between the pressure measurements, and the traveling waves (as outlined in Section 3.2.1) could be used to back-calculate for g , as was done in [4] for a simple step input signal. However, the process outlined here is slightly

more complicated in this instance, as we are dealing with a system that is driven by hydraulic noise, not a tailored input signal.

At this point, we make the mild assumption that the hydraulic noise generated at the upstream reservoir $p_o(t)$ is wide-sense stationary. This means is that the hydraulic noise possesses stationary first and second order statistics, and as such can be completely represented by an autocorrelation function. As a result of the stationarity of the statistics of the upstream reservoir fluctuations, the pressure measurements $p_A(t)$ and $p_B(t)$ will also be stationary noise processes as they are driven by $p_o(t)$ passed through a nearly linear, but certainly time-invariant, system (i.e. the upstream section of pipe). By implication, the time series for the transmitted $p_A^+(t)$ and reflected $p_B^-(t)$ waves are also wide-sense stationary [given their dependence on $p_A(t)$ and $p_B(t)$]. As a consequence of this, the transform of g (the system transfer function) can be given by the standard spectral density relationship between the power and cross spectra of the input and output signals (e.g. see [10] for details), namely, the separated wave components. Through the relationships outlined in Section 3.2.1 these wave component spectral densities can be obtained directly from the spectral densities of the pressure measurements at A and B. Using standard inverse transform procedures, the impulse response can be computed from the transfer function.

4. Numerical case study

4.1. Preliminaries

The numerical system under study is depicted in Fig. 1. All lengths are as shown, and the intact pipe was assumed to have a diameter of 200 mm, a friction factor of 0.02, and a wave speed of 1000 m/s. The damaged sections of pipe were assumed to mimic internally corroded sections, with internal diameters of 205 and 201 mm, friction factors of 0.025 and 0.03, and wave speeds of 800 and 850 m/s. The upstream boundary condition was taken as a source elevation, with a mean of 25 m of head with uniform random fluctuations about this of ± 10 m. The downstream boundary condition was taken as a reservoir with fixed elevation of 0. The raw data was synthetically generated using the method of characteristics with $\Delta t = 0.001$ s. The model was run for a total of 10,000 time points, where the first quarter was omitted from the analysis as the system was still achieving a statistically stationary behavior.

4.2. Results and discussion

Example time traces of the head measured at position A, and the cross spectral density between A and B are given in Figs 3(a) and 3(b) below. These plots show that, in and of themselves, nothing concerning the condition of the pipe can be clearly observed. However, they are the necessary raw data for the detection methodology.

The impulse response function g computed as the inverse transform of the computed transfer function mapping between $p_A^+(t)$ and $p_B^-(t)$ is given in Fig. 4. As outlined in Section 3.2.2, the impulse response is computed directly from the spectral density functions similar to the cross spectral density as depicted in Fig. 3(b).

For a fully intact pipe, the impulse response would appear as a flat line (with some noise) followed by a large negative spike associated with the reflection from the downstream reservoir. Within the impulse response depicted in Fig. 4, the large negative peak associated with the reflection from the reservoir is observed, however, as is clear from this impulse response trace, two additional peak events were observed. The presence of these spikes in the impulse response indeed indicates that there are sections of significant impedance change along the length of the pipe (i.e. the corroded sections). In assessing the time delay of these peak events, it is seen that the first peak event appears at time point 0.734 s which is exactly associated with the location of the first damaged section (i.e. the time required for a wave to leave point A, pass through point B, reflect off the damaged section and return back to point B). Additionally, the second peak arises at 0.842 seconds, which is the delay associated with the second damaged section.

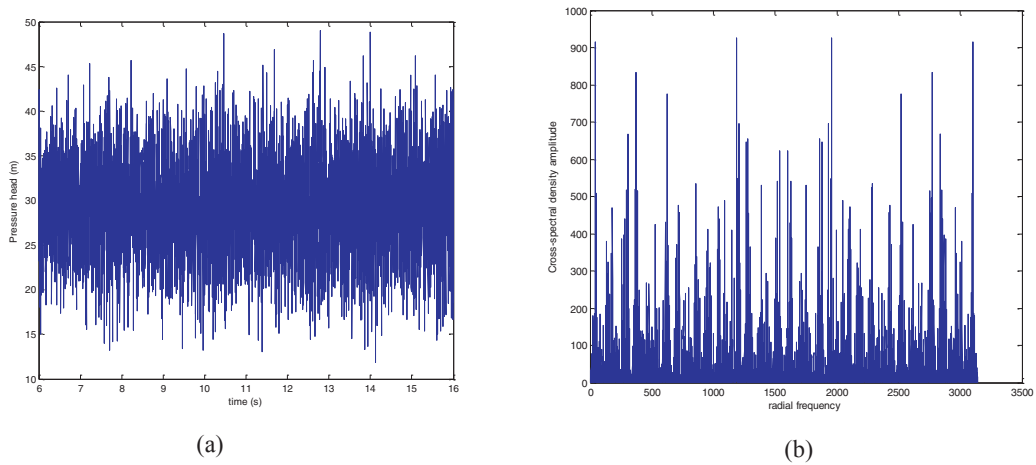

Fig 3. (a) Example of pressure head trace measured at position A. (b) Example of cross power spectral density as computed from the synthetic data

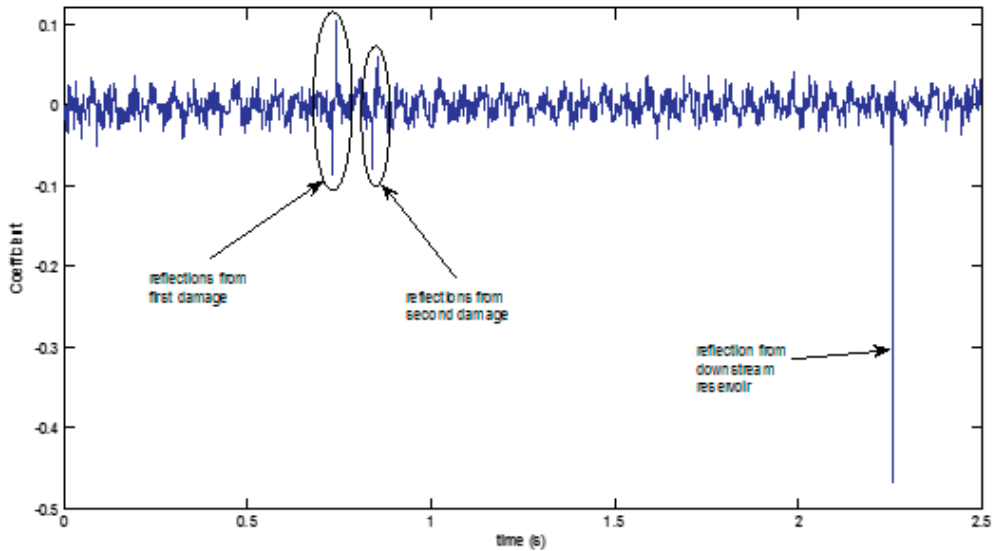

Fig 4. Impulse response function of the downstream section of pipe.

An interesting point to note is that the events appear first as negative peaks, and secondly as positive peaks. This first negative peak is associated with a reflection from an impedance drop (i.e. as the wave enters the damaged section), the positive peak is associated with a reflection from an impedance jump (i.e. the wave exits the damaged section, and enters the intact pipeline).

5. Conclusions

This paper presents a methodology that uses only the background transient hydraulic noise (in the form of a wide-sense stationary signal) to detect condition faults within a pipeline system. The method uses two closely spaced pressure sensors to split the signal into its axial wave components, and then determines the reflection trace of the downstream section of pipe as the impulse response function mapping from the incident wave traveling downstream along the pipe to the reflected wave traveling upstream the pipe. The method was shown to work for a simple numerical case study.

References

- [1] M. L. Stephens, M. F. Lambert, A. R. Simpson, Determining the internal wall condition of a water pipeline in the field using an inverse transient model, *Journal of Hydraulic Engineering*, 139, (2013) 310–324.
- [2] J. Gong, A. R. Simpson, M. F. Lambert, A. C. Zecchin, Y. Kim, A. S. Tijsseling, Detection of distributed deterioration in single pipes using transient reflections, *Journal of Pipeline Systems Engineering and Practice*, 4 (2013) 32–40.
- [3] J. Tuck, P. J. Lee, M. Davidson, M. S. Ghidaoui, Analysis of transient signals in simple pipeline systems with an extended blockage, *Journal of Hydraulic Research*, 51 (2013) 623–633.
- [4] J. Gong, M. F. Lambert, A. R. Simpson, A. C. Zecchin, Distributed deterioration detection in single pipelines using transient measurements from pressure transducer pairs, in 11th International Conference on Pressure Surges, Lisbon, Portugal, 2012, 127–140.
- [5] J. Lee, J. P. Vítkovský, M. F. Lambert, A. R. Simpson, J. A. Liggett, Leak location using the pattern of the frequency response diagram in pipelines: a numerical study, *Journal of Sound and Vibration*, 284 (2005) 1051–1073.
- [6] J. Gong, M. F. Lambert, A. R. Simpson, A. C. Zecchin, Single event leak detection in a pipeline using the first three resonant responses, *Journal of Hydraulic Engineering*, 139 (2013) 645–655.
- [7] A.C. Zecchin, M.F. Lambert; A.R. Simpson; L.B. White, Parameter identification in pipeline networks: A transient based expectation-maximization approach for systems containing unknown boundary conditions, *Journal of Hydraulic Engineering*, 140 (2014), 04014020.
- [8] A.C. Zecchin, L.B. White, M.F. Lambert, A.R. Simpson, Parameter identification of fluid line networks by frequency-domain maximum likelihood estimation. *Mechanical Systems and Signal Processing*, 37 (2013) 370–387.
- [9] E.B. Wylie, V.L. Streeter, *Fluid Transients in Systems*, Prentice Hall, Upper Saddle River, NJ, 1993.
- [10] P. Athanasios, *Signal Analysis*, McGraw-Hill, 1977.